

- NOTES:**
1. MATERIAL: BRASS, .006/(.15) TH'K., ALLOY 260
 2. MATERIAL: PHOS. BRONZE, .006/(.15) TH'K., ALLOY 510
 3. THIS PART TO CONFORM TO MOLEX SOLDERABILITY SPEC. 152.
 4. PRODUCT SPECIFICATION: PS-4706-001
 5. RECOMMENDED .051±.002 DIA. HOLE FOR .062 TH'K. PCB.
 6. TOOLING MUST BE ORDERED BY AWG. WIRE SIZE.
 7. 4811-***A(***)** TERMINAL WILL ACCOMMODATE #22 TO 26 AWG. WIRE WITH .100/(2.54) MAX. DIA. INSULATION.
 8. 4811-**C(**)**** TERMINAL WILL ACCOMMODATE #22 TO 26 AWG. WIRE WITH .060/(1.52) MAX. DIA. INSULATION.
 9. PLATING PER SDES-88, PLATING MUST MEET SPEC. ON OUTER SURFACES.

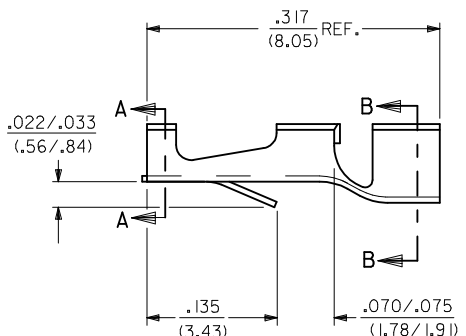
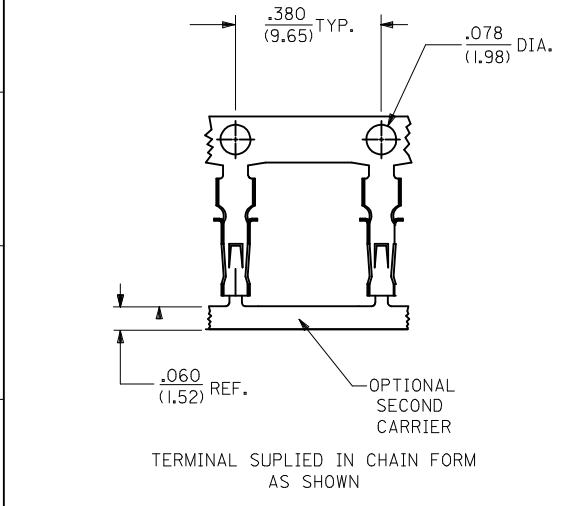

4811-***A(***)**

MATERIAL:
A=BRASS, ALLOY 260
SEE NOTE 1
B=PHOS. BRONZE
SEE NOTE 2

CARRIER OPTION:
A= SINGLE CARRIER
B= DOUBLE CARRIER

SPICE OPTION
BLANK= SPLICED REEL PER ES-339
I= SPLICE FREE REEL

FORM:
CA= CHAIN PER ES-339-A
CB= CHAIN PER ES-339-B

CODE	DIMENSION			WIRE SIZE
	"A"	"B"	"C" RAD.	
A	.140±.005 (3.56±.13)	.170±.010 (4.32±.25)	.062 (1.57)	SEE NOTE 7
C	.082±.005 (2.08±.13)	.092±.010 (2.34±.25)	.031 (.79)	SEE NOTE 8

PLATING CODE:

(FOR ADDITIONAL PLATING, SEE SDES-88)

*909 OVERALL HOT TIN DIP: 2.54 MICROMETERS MIN.

*THE PRIMARY SHIPPING CARTON WILL BE LABELED "COMPLIANT TO RoHS DIRECTIVE 2002/95/EC AND ELV ANNEX II OF DIRECTIVE 2000/53/EC." CARTONS WITHOUT THIS LABEL MAY CONTAIN PRODUCT WITH TIN-LEAD PLATING.

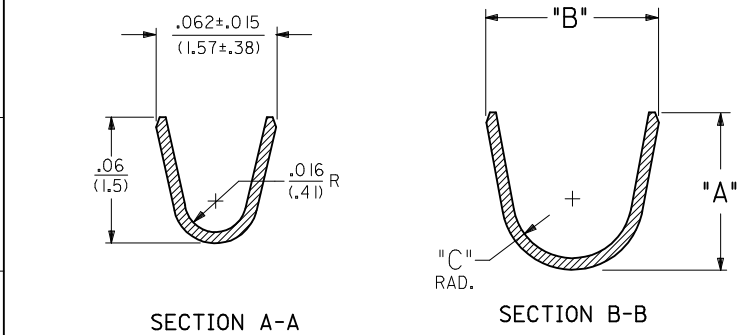

SEE CHART EC NO: UCP2005-0973 DRW:ADRATNOL 2004/11/19 CHKD:SAMEC 2004/04/08/89 APPR:MMRGGULIUS 2004/11/08/84	QUALITY SYMBOLS ▽=0 ▽=0	GENERAL TOLERANCES (UNLESS SPECIFIED) <table border="1"> <tr> <th></th> <th>mm</th> <th>INCH</th> </tr> <tr> <td>4 PLACES ±</td> <td>---</td> <td>---</td> </tr> <tr> <td>3 PLACES ±</td> <td>---</td> <td>±.010</td> </tr> <tr> <td>2 PLACES ±</td> <td>0.25</td> <td>±.014</td> </tr> <tr> <td>1 PLACE ±</td> <td>0.35</td> <td>---</td> </tr> </table>		mm	INCH	4 PLACES ±	---	---	3 PLACES ±	---	±.010	2 PLACES ±	0.25	±.014	1 PLACE ±	0.35	---	DIMENSION STYLE IN/MM	SCALE ---	DESIGN UNITS INCH	THIRD ANGLE PROJECTION
		mm	INCH																		
	4 PLACES ±	---	---																		
	3 PLACES ±	---	±.010																		
2 PLACES ±	0.25	±.014																			
1 PLACE ±	0.35	---																			
DRAWN BY GMC DATE 05/02/89	CHECKED BY PATEL DATE 05/02/89	APPROVED BY LENZ DATE 05/02/89	TITLE TERMINAL, STRAIN RELIEF 4811 SERIES DWG	MATERIAL NO. SEE CHART	DOCUMENT NO. SD-4811-*	SHEET NO. 1 OF 3															
DRAFT WHERE APPLICABLE MUST REMAIN WITHIN DIMENSIONS	ANGLULAR ±1/2°	MOLEX MOLEX INCORPORATED	THIS DRAWING CONTAINS INFORMATION THAT IS PROPRIETARY TO MOLEX INCORPORATED AND SHOULD NOT BE USED WITHOUT WRITTEN PERMISSION																		
AU1	REV																				

