

Features and Benefits

- Replacement of manual splices by standard solution
- Compliant with ESA/ESCC specifications
- Easy to use
- Removable D*MA crimp type contacts standard
- Compact format and designed to accept the most popular cable gauges
- Non-outgassing
- Low residual magnetism
- High radiation and temperature resistance (PEEK material)

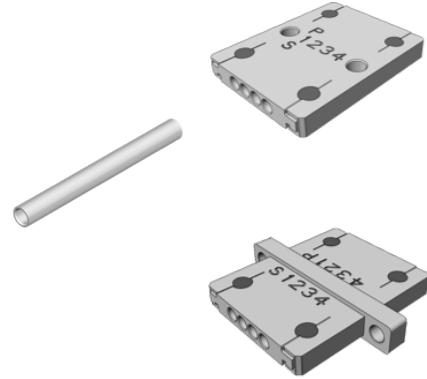

Typical Applications

- Space equipment
- Satellites harnesses and payloads
- Avionics/ Military

Specification

- High performance wires to wires connectors ESA qualified, for space applications.
- Compliant to ESCC specifications 3401/097 Connectors and 3401/005 Removable Crimp Contacts.
- Suitable for use in Space, and high performance military/ aerospace applications: Board to Board, Board to Cable or Cable to Cable applications.
- Removable contacts (D*MA technology).
- Cable sizes: AWG20, AWG22, AWG24, AWG26 and AWG28.
- 1 way and 4 ways connections available.
- 4 ways variants:
 - Radial fixing mount (Stackable)
 - Axil fixing for panel mount

Electrical & Mechanical Characteristics

CHARACTERISTIC	SPECIFICATION
Working Voltage - 1 way (sea level)	300 Vrms
Working Voltage - 4 ways (sea level)	250 Vrms
Rated Current	7.5 A
Contact Resistance	5 mΩ (rated current)
Insulation Resistance at 500 V DC	50 MΩ min
Voltage Proof - 1 way	1250 Vrms /2.0mA
Voltage Proof - 4 ways	1000 Vrms /2.0mA
Residual Magnetism Level (NMB)	<200 Gama
Temperature Range	-55/+125 °C
Radiation Resistance	>1x10 ⁶ Rads
Contact Retention Force	40 N max

Quality Level

- ESA / ESCC: code 3401 (Flying model).
- Qualification reviewed every 2 years.

Process Contact and Cable Insertion

- Cables crimping onto contacts with standard D*MA Crimping tool M22520/2-01 and locator M22520/2-08 (to be ordered separately).
- Wires cable installed by the end user.

Test Retention

- A dedicated tool is available to make the retention test of each contacts in the connectors.

Process Contact and Cable Extraction

- A dedicated tool M81969/39-01 is available to remove the contacts from the connectors (1 extract tool delivered per bag).

Packaging

- Space Splice 1 way: 50 pcs per bag. One extract tool M81969/39-01 delivered per bag.
- Space Splice 4 ways: Individual packaging. One extract tool M81969/39-01 delivered par bag.
- Traceability associated as per ESA/ESCC specifications.

MATERIALS & FINISHES

COMPONENT	MATERIAL	FINISH
Insulator	PEEK	UL-94-V0, natural color
Retention Clip	Beryllium Copper Alloy	Raw material
Socket Contacts	Copper Alloy	1.27 μm Gold over Copper underlay
Pin Contacts	Copper Alloy	1.27 μm Gold over Copper underlay

SPACE SPLICE 1 WAY

Wire to Wire Connection



PART NUMBER - DESCRIPTION

Part Number: **C115366-2776C**

ESA/ESCC Description: **340109701B**

DIMENSIONS & WEIGHT

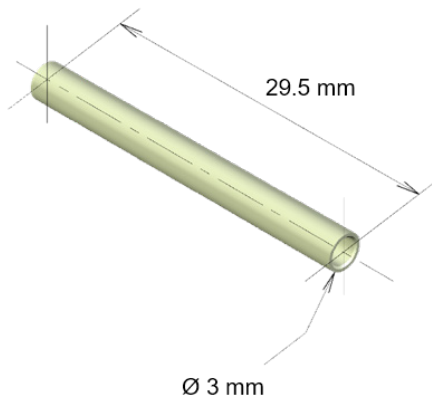

Mass: 0.2 gr

USE EXPLANATION

Wires to wires connecting solution

- To crimp pin and Socket D*MA contacts with wires (such as D*MA connectors)

- Insert the contacts into Space Splice (manually or using D*MA insertion tool)

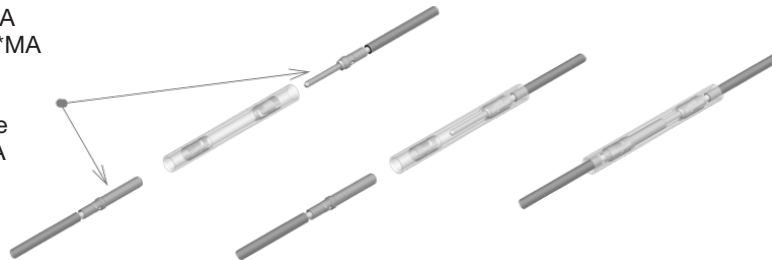

- For insertion of contacts wired with AWG26/28 (without shrinkable tube), the use of insertion tool is mandatory
- If different wire sizes are used on each contact side, insert contact with smallest wire size first to perform retention test by pushing

SPACE SPLICE 4 WAYS
Radial Fixing Variant
Stackable

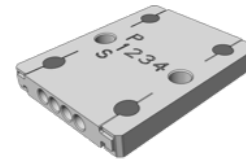

PART NUMBER - DESCRIPTION

Part Number: C115366-3014C	ESA/ESCC Description: 340109702B 04RA3014
-----------------------------------	--

DIMENSIONS & WEIGHT

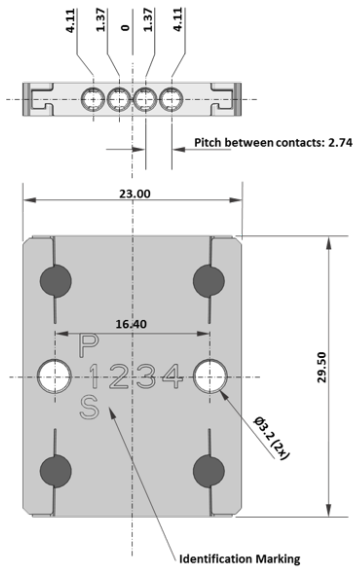

Mass: 3.5 gr

USE EXPLANATION

Wires to wires connecting solution
 Floating or possibility of fixing the insulator using 2 through holes

Possibility of Stacking Products

- To crimp pin and Socket D*MA contacts with wires (such as D*MA connectors)
- Insert the contacts into Space Splice (manually or using D*MA insertion tool)

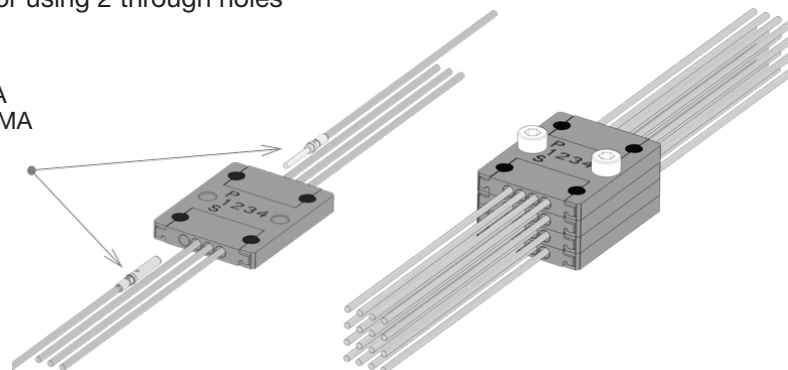

- For insertion of contacts wired with AWG26/28 (without shrinkable tube), the use of insertion tool is mandatory
- If different wire sizes are used on each contact side, insert contact with smallest wire size first to perform retention test by pushing

Dimensions shown in: mm
 Specifications and dimensions subject to change

SPACE SPLICE 4 WAYS
Axial Fixing Variant
Panel Mount

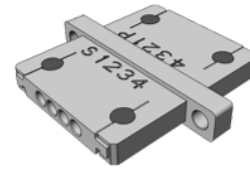

PART NUMBER - DESCRIPTION

Part Number: C115366-3015C	ESA/ESCC Description: 340109702B 04AA3015
-----------------------------------	--

DIMENSIONS & WEIGHT

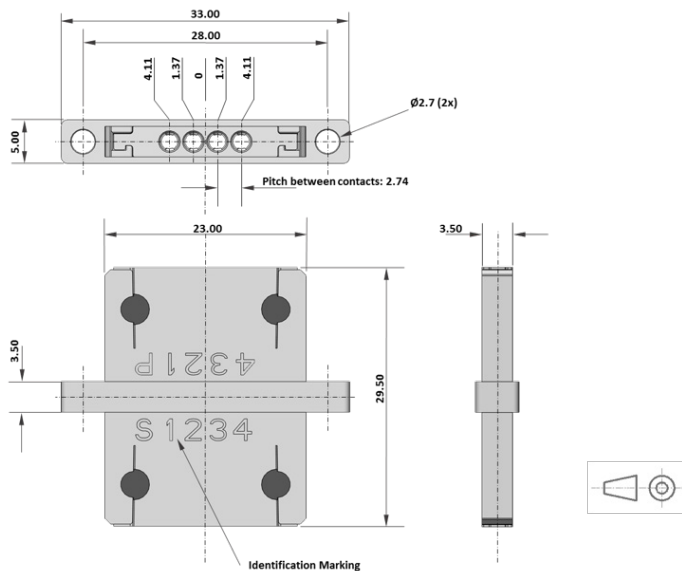

Mass: 4 gr

USE EXPLANATION

Wires to wires connecting solution
 Use to pass through panels

- To crimp pin and Socket D*MA contacts with wires (such as D*MA connectors)
- Insert the contacts into Space Splice (manually or using D*MA insertion tool)

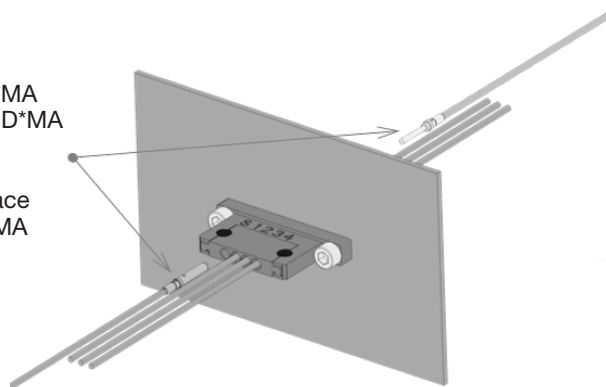

Panel Cut-Out Profile

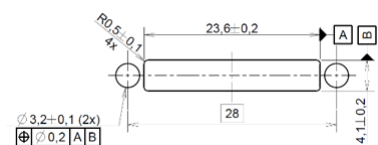

- For insertion of contacts wired with AWG26/28 (without shrinkable tube), the use of insertion tool is mandatory
- If different wire sizes are used on each contact side, insert contact with smallest wire size first to perform retention test by pushing



Dimensions shown in: mm
 Specifications and dimensions subject to change

D*MA Contact Pin - Size 20/20 (wire size AWG20, AWG22, AWG24)

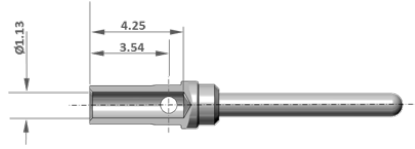
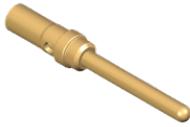

C&K Part Number: **C330-8996-101H**

ESA/ESCC Description: **340100501B**

D*MA Contact Pin - Size 20/26 (wire size AWG26, AWG28)

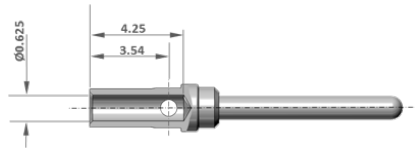
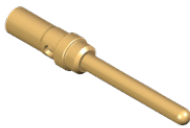

C&K Part Number: **C330-8997-101H**

ESA/ESCC Description: **340100503B**

D*MA Contact Socket - Size 20/20 (wire size AWG20, AWG22, AWG24)

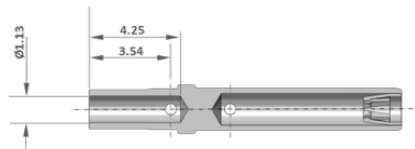

C&K Part Number: **C031-8996-101H**

ESA/ESCC Description: **340100502B**

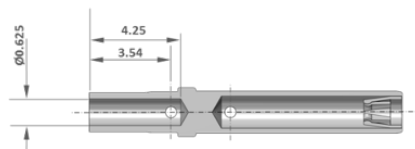

D*MA Contact Socket - Size 20/26 (wire size AWG26, AWG28)



C&K Part Number: **C031-8997-101H**

ESA/ESCC Description: **340100504B**

ACCESSORIES

Crimping Tool	DESCRIPTION	C&K PART NUMBER
	M22520/2-01	C995-0001-584
Locator	DESCRIPTION	C&K PART NUMBER
	M22520/2-08	C995-0001-604
Insertion / Extraction Tool	DESCRIPTION	C&K PART NUMBER
	M81969/39-01	C980-2000-426
All Space Splice: Contact Probe for Retention Tool - Push Test	DESCRIPTION	C&K PART NUMBER
 <p>← 6-32 UNC-2A Compatible with OCETA OCE8</p>	<p>Push test recommended value: All wire size: 20N max</p>	SPLICE-TOOL-RETENTION-01
Space Splice 1 way only: Contact Probe for Retention Tool - Pull Test	DESCRIPTION	C&K PART NUMBER
 <p>← 6-32 UNC-2A Compatible with OCETA OCE8</p>	<p>Pull test recommended value: AWG20, 22, 24, 26: 20N max AWG28: 10N max</p>	SPLICE-TOOL-RETENTION-02

HDS ESCC Space Splice - July 2021



Dimensions shown in: mm
Specifications and dimensions subject to change