

ICL7663/7664

CMOS Programmable

Micropower Voltage Regulators



ICL7663/7664

GENERAL DESCRIPTION

The ICL7663 (positive) and ICL7664 (negative) series regulators are low-power, high-efficiency devices which accept inputs from 1.6V to 10V and provide adjustable outputs over the same range at currents up to 40mA. Operating current is typically less than 4 μ A, regardless of load.

Output current sensing and remote shutdown are available on both devices, thereby providing protection for the regulators and the circuits they power. A unique feature, on the ICL7663 only, is a negative temperature coefficient output. This can be used, for example, to efficiently tailor the voltage applied to a multiplexed LCD through the driver (e.g., ICM7231/2/3/4) so as to extend the display operating temperature range many times.

The ICL7663 and ICL7664 are available in either an 8-pin plastic, TO-99 can, CERDIP, and SOIC packages.

ORDERING INFORMATION

POSITIVE REGULATOR		
PART NUMBER	TEMPERATURE RANGE	PACKAGE
ICL7663CBA	0°C to +70°C	8-Lead SOIC
ICL7663CPA	0°C to +70°C	8-Lead MiniDIP
ICL7663CJA	0°C to +70°C	8-Lead CERDIP
ICL7663/D	—	DICE**
ICL7663CTV	0°C to +70°C	8-Lead TO-99

FEATURES

- Ideal for Battery-Operated Systems: Less Than 4 μ A Typical Current Drain
- Will Handle Input Voltages From 1.6V to 16V
- Very Low Input-Output Differential Voltage
- 1.3V Bandgap Voltage Reference
- Up to 40mA Output Current
- Output Shutdown Via Current-Limit Sensing or External Logic Signal
- Output Voltages Programmable From 1.3V to 16V
- Output Voltages With Programmable Negative Temperature Coefficients (ICL7663 Only)

NEGATIVE REGULATOR		
PART NUMBER	TEMPERATURE RANGE	PACKAGE
ICL7664/D	—	DICE**
ICL7664CBA	0°C to +70°C	8-Lead SOIC
ICL7664CJA	0°C to +70°C	8-Lead CERDIP
ICL7664CPA	0°C to +70°C	8-Lead MiniDIP
ICL7664CTV	0°C to +70°C	8-Lead TO-99

**Parameter Min/Max Limits guaranteed at 25°C only for DICE orders.

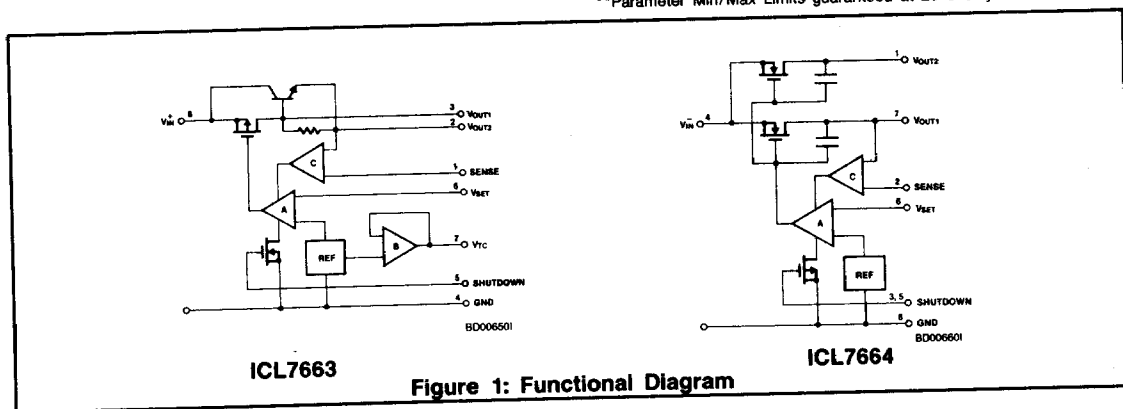

ABSOLUTE MAXIMUM RATINGS, ICL7663 POSITIVE REGULATOR

Input Supply Voltage +18V
 Any Input or Output Voltage (Note 1) (Terminals 1, 2, 3, 5, 6, 7).....(GND -0.3V) to (V_{IN} +0.3V)
 Output Source Current
 (Terminal 2) 50mA
 (Terminal 3) 25mA

Output Sinking Current (Terminal 7) -10mA
 Power Dissipation (Note 2)
 MiniDIP 200mW
 TO-99 Can 300mW
 Operating Temperature Range 0°C to +70°C
 Storage Temperature -65°C to +150°C
 Lead Temperature (Soldering, 10sec) 300°C

Stresses above those listed under "Absolute Maximum Ratings" may cause permanent damage to the device. These are stress ratings only and functional operation of the device at these or any other conditions above those indicated in the operational sections of the specifications is not implied. Exposure to absolute maximum rating conditions for extended periods may affect device reliability.

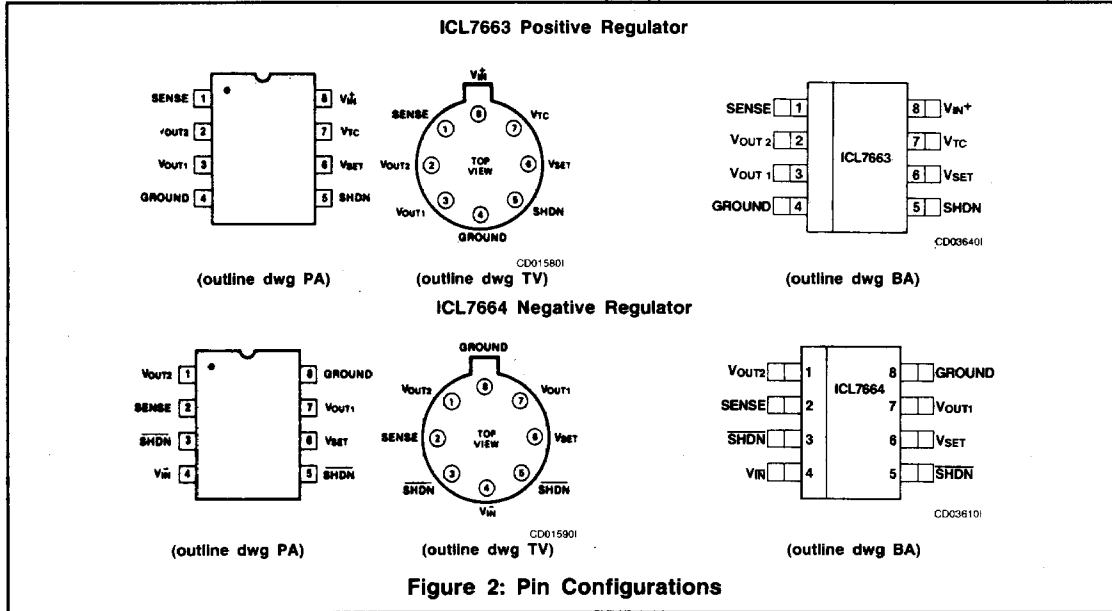

Figure 2: Pin Configurations

ICL7663 ELECTRICAL CHARACTERISTICS

$V_{IN} = 9V$, $V_{OUT} = 5V$, $T_A = +25^\circ C$, unless otherwise specified. See Test Circuit Figure 3.

SYMBOL	PARAMETER	TEST CONDITIONS	LIMITS			UNIT
			MIN	TYP	MAX	
V_{IN}	Input Voltage	$T_A = +25^\circ C$ $0^\circ C \leq T_A \leq +70^\circ C$	1.5 1.6		16.0 16.0	V
I_Q	Quiescent Current	$\left. \begin{matrix} R_L = \infty \\ 1.4V \leq V_{OUT} \leq 8.5V \end{matrix} \right\} \begin{matrix} V_{IN} = 16V \\ V_{IN} = 9V \end{matrix}$		4.0 3.5	12 10	μA
V_{SET}	Reference Voltage		1.2	1.3	1.4	V
$\frac{\Delta V_{SET}}{\Delta T}$	Temperature Coefficient	$8.5V < V_{IN} < 9V$		± 200		ppm
$\frac{\Delta V_{SET}}{V_{SET} \Delta V_{IN}}$	Line Regulation	$2V < V_{IN} < 9V$		0.03		%/V
I_{SET}	V_{SET} Input Current			± 0.01	10	nA
I_{SHDN}	Shutdown Input Current			± 0.01	10	nA
V_{SHDN}	Shutdown Input Voltage	V_{SHDNHI} : Both V_{OUT} Disabled V_{SHDNLO} : Both V_{OUT} Enabled	1.4		0.3	V

ICL7663/7664

ICL7663 ELECTRICAL CHARACTERISTICS (CONT.)

SYMBOL	PARAMETER	TEST CONDITIONS	LIMITS			UNIT
			MIN	TYP	MAX	
I_{SENSE}	Sense Pin Input Current			0.01	10	nA
V_{CL}	Sense Pin Input Threshold Voltage	$V_{CL} = V_{OUT2} - V_{SENSE}$ (Current-Limit Threshold)		0.7		V
R_{SAT}	Input-Output On-Resistance (Note 3)	$V_{IN} = 2V$ $V_{IN} = 9V$ $V_{IN} = 15V$		200 70 50		Ω
$\frac{\Delta V_{OUT}}{\Delta I_{OUT}}$	Load Regulation	$\Delta I_{OUT1} = 100\mu A$ @ $V_{OUT1} = 5V$ $\Delta I_{OUT2} = 10mA$ @ $V_{OUT2} = 5V$		2.0 1.0		Ω
I_{OUT2}	Available Output Current (V_{OUT2})	$V_{IN} = 3V$ $V_{OUT} = V_{SET}$ $V_{IN} = 9V$ $V_{OUT} = 5V$ $V_{IN} = 15V$ $V_{OUT} = 5V$	10 25 40			mA
V_{TC}	Negative-Tempco Output (Note 4)	Open-Circuit Voltage		0.9		V
I_{TC}		Maximum Sink Current	0	8	2.0	mA
$\frac{\Delta V_{TC}}{\Delta T}$	Temperature Coefficient of V_{TC} Output	Open Circuit		+2.5		mV/ $^{\circ}C$
$I_{L(min)}$	Minimum Load Current	(Includes V_{SET} Divider)	1.0			μA

- NOTES:** 1. Connecting any terminal to voltages greater than ($V_{IN} + 0.3V$) or less than ($GND - 0.3V$) may cause destructive device latchup. It is recommended that no inputs from sources operating on external power supplies be applied prior to ICL7663B power-up.
2. Derate linearly above $50^{\circ}C$ at $5mW/^{\circ}C$ for minidip and $7.5mW/^{\circ}C$ for TO-99 can.
3. This parameter refers to the on-resistance of the MOS pass transistor. The minimum input-output voltage differential at low current (under 5mA), can be determined by multiplying the load current (including set resistor current, but not quiescent current) by this resistance.
4. This output has a positive temperature coefficient. Using it in combination with the inverting input of the regulator at V_{SET} , a negative coefficient results in the output voltage. See Figure 4 for details. Pin will not source current.

ABSOLUTE MAXIMUM RATINGS, ICL7664 NEGATIVE REGULATOR

Input Supply Voltage -18V
 Any Input or Output Voltage (Note 1) Terminals 1, 2, 3,
 4, 5, 6, 7).....(GND +0.3V) to (V_{IN} -0.3V)
 Output Sink Current
 (Terminals 1, 7) 25mA

Power Dissipation (Note 2)
 MiniDIP 200mW
 TO-99 300mW
 Operating Temperature Range 0°C to +70°C
 Storage Temperature Range -65°C to +150°C
 Lead Temperature (Soldering, 10sec) 300°C

Stresses above those listed under "Absolute Maximum Ratings" may cause permanent damage to the device. These are stress ratings only and functional operation of the device at these or any other conditions above those indicated in the operational sections of the specifications is not implied. Exposure to absolute maximum rating conditions for extended periods may affect device reliability.

ICL7664 ELECTRICAL CHARACTERISTICS

$V_{IN} = -9V$, $V_{OUT} = -5V$, $T_A = +25^\circ C$, unless otherwise specified. See Test Circuit Figure 3.

SYMBOL	PARAMETER	TEST CONDITIONS	LIMITS			UNIT
			MIN	TYP	MAX	
V_{IN}	Input Voltage	$T_A = +25^\circ C$ $0^\circ C \leq T_A \leq +70^\circ C$	-1.5 -1.6		-16.0 -16.0	V
I_Q	Quiescent Current	$\left\{ \begin{array}{l} R_L = \infty \\ -1.4V \leq V_{OUT} \leq -8.5V \end{array} \right\}$ $V_{IN} = 16V$ $V_{IN} = 9V$		4.0 3.5	12 10	μA
V_{SET}	Reference Voltage		-1.2	-1.3	-1.4	V
$\frac{\Delta V_{SET}}{\Delta T}$	Temperature Coefficient	$-8.5V < V_{IN} < -9V$		± 200		ppm
$\frac{\Delta V_{SET}}{V_{SET} \Delta V_{IN}}$	Line Regulation	$-2V < V_{IN} < -9V$		0.03		%/V
I_{SET}	V_{SET} Input Current			± 0.01	10	nA
I_{SHDN}	Shutdown Input Current			± 0.01	10	nA
V_{SHDN}	Shutdown Input Voltage	V_{SHDNHI} : Both V_{OUT} Disabled V_{SHDNLO} : Both V_{OUT} Enabled	-0.3		-1.6	V
I_{SENSE}	Sense Pin Input Current			0.01	10	nA
V_{CL}	Sense Pin Input Threshold Voltage	$V_{CL} = V_{OUT2} - V_{SENSE}$ (Current-Limit Threshold)		-0.35		V
R_{SAT}	Input-Output On-Resistance (Note 3)	$V_{IN} = 2V$ $V_{IN} = 9V$ $V_{IN} = 15V$		150 40 30		Ω
$\frac{\Delta V_{OUT}}{\Delta I_{OUT}}$	Load Regulation	$\Delta I_{OUT1} = 100\mu A @ V_{OUT} = -5V$		2.0		Ω
I_{OUT}	Output Current V_{OUT1} or V_{OUT2}	$V_{IN} = 3V V_{OUT} = V_{SET}$ $V_{IN} = 9V V_{OUT} = -5V$ $V_{IN} = 15V V_{OUT} = -5V$		-2 -20 -40		mA
$I_{L(min)}$	Minimum Load Current (Includes V_{SET} Divider)		1.0			μA

- NOTES:** 1. Connecting any terminal to voltages greater than (GND +0.3V) or less than (V_{IN} -0.3V) may cause destructive device latchup. It is recommended that no inputs from sources operating on external power supplies be applied prior to ICL7664 power-up.
 2. Derate linearly above 50°C at 5mW/°C for minidip and 7.5mW/°C for TO-99 can.
 3. This parameter refers to the on-resistance of the MOS pass transistor. The minimum input-output voltage differential can be determined by multiplying the load current (including set resistor current, but not quiescent current) by this resistance.

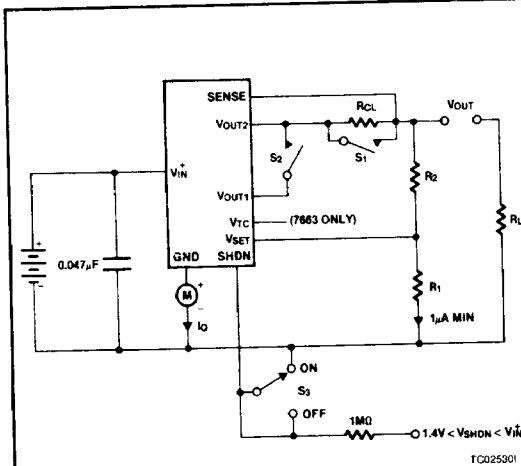

- NOTES:**
1. S_1 when closed, disables output current limiting.
 2. For ICL7664, exchange V_{OUT1} and V_{OUT2} . S_2 action differs, as follows:

DEVICE	S_2 CLOSED	S_2 OPEN
ICL7663	V_{OUT1}	V_{OUT2}
ICL7664	$V_{OUT1} + V_{OUT2}$	V_{OUT1}

3.
$$V_{OUT} = \frac{R_2 + R_1}{R_1} V_{SET}$$
4. I_Q quiescent current is measured at GND pin by meter M.
5. S_3 when ON, permits normal operation, when OFF, shuts down both V_{OUT1} and V_{OUT2} .

Figure 3: Test Circuit for ICL7663/64 (Polarities shown are for ICL7663. Reverse for ICL7664)

TYPICAL PERFORMANCE CHARACTERISTICS

ICL7663 OUTPUT VOLTAGE AS A FUNCTION OF OUTPUT CURRENT

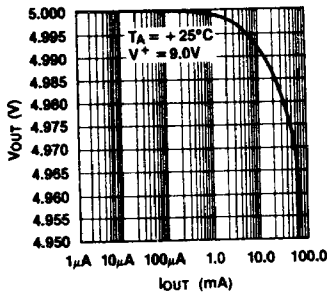

ICL7663 V_{OUT1} INPUT-OUTPUT DIFFERENTIAL VS OUTPUT CURRENT

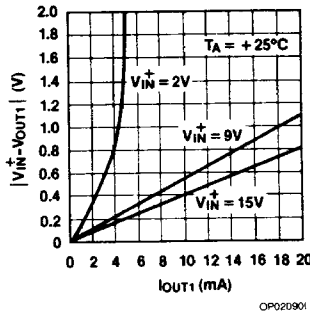

ICL7663 V_{OUT2} INPUT-OUTPUT DIFFERENTIAL VS OUTPUT CURRENT

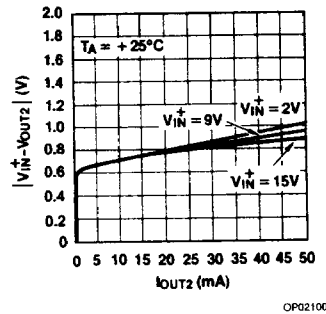

ICL7663 INPUT POWER REJECTION RATIO

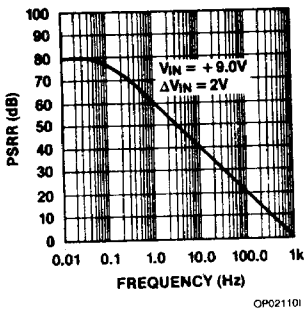

ICL7663 QUIESCENT CURRENT AS A FUNCTION OF INPUT VOLTAGE

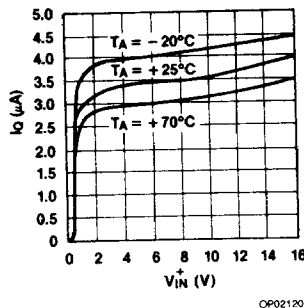

ICL7663 QUIESCENT CURRENT AS A FUNCTION OF TEMPERATURE

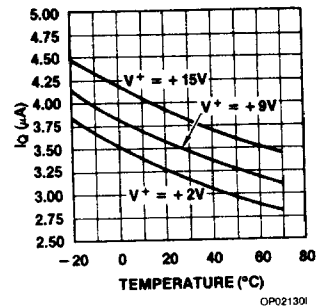

TYPICAL PERFORMANCE CHARACTERISTICS (CONT.)

ICL7664 OUTPUT VOLTAGE AS A FUNCTION OF OUTPUT CURRENT

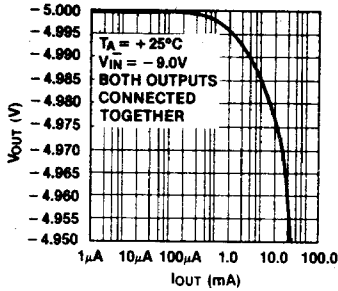

OP021401

ICL7664 VOUT1 INPUT-OUTPUT DIFFERENTIAL VS OUTPUT CURRENT

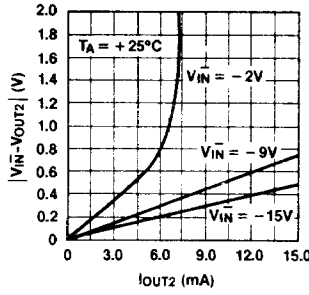

OP021501

ICL7664 VOUT2 INPUT-OUTPUT DIFFERENTIAL VS OUTPUT CURRENT

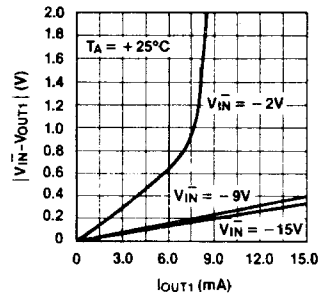

OP021601

ICL7664 INPUT POWER SUPPLY REJECTION RATIO

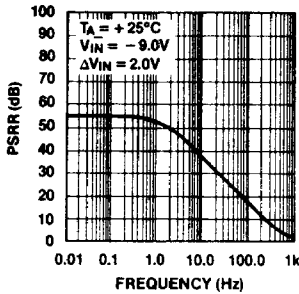

OP021701

ICL7664 QUIESCENT CURRENT AS A FUNCTION OF INPUT VOLTAGE

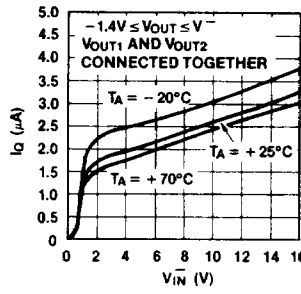

OP021801

ICL7664 QUIESCENT CURRENT AS A FUNCTION OF TEMPERATURE

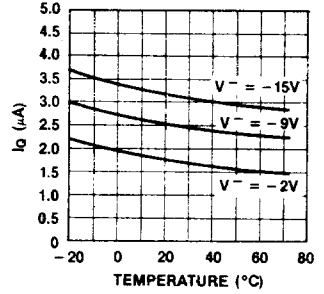

OP021901

DETAILED DESCRIPTION

The ICL7663 and ICL7664 are CMOS integrated circuits which contain all the functions of a voltage regulator plus protection circuitry on a single monolithic chip. Referring to the functional diagrams (Figure 1), it can be seen that each contains a bandgap-type voltage reference of 1.3 Volts. This voltage, therefore, is the lowest output voltage the regulators can control (-1.3V for the ICL7664). Error amplifier A drives either a P-channel (ICL7663) or an N-channel (ICL7664) pass transistor which is sufficient for low (under about 5mA) currents; this transistor is augmented by a duplicate in the ICL7664, which permits higher current outputs. In the ICL7663, the high current output is passed by an NPN bipolar transistor connected as a follower. This configuration gives more gain and lower output impedance.

Logic-controlled shutdown is implemented via an MOS transistor of the appropriate polarity. Current-sensing is achieved with comparator C, which functions with the VOUT2 line on each chip. Finally, the positive regulator (ICL7663 only) has an output (VTC) from a buffer amplifier (B), which can be used to generate programmable-temperature-coefficient output voltages.

The amplifiers, reference and comparator circuitry all operate at bias levels well below 1µA to achieve the

extremely low quiescent current. This does limit the dynamic response of the circuits, however, and transients are best dealt with outside the regulator loop.

BASIC OPERATION

The ICL7663 and ICL7664 are designed to regulate battery voltages in the 5V to 15V region at maximum load currents of about 5mA to 30mA. Although intended as low power devices, power dissipation limits must be observed. For example, the power dissipation in the case of a 10V supply regulated down to 2V with a load current of 30mA clearly exceeds the power dissipation rating of the minichip: $(10 - 2)(30) (10^{-3}) = 240\text{mW}$. The test circuit illustrates proper use of the devices. Although the following discussion refers to the ICL7663, it applies as well to the parallel features of the ICL7664 as long as the appropriate polarities are reversed. Individual features and precautions will be discussed where appropriate.

CMOS devices generally require two precautions: every input pin must go somewhere, and maximum values of applied voltages and current limits must be rigorously observed. Neglecting these precautions may lead to, at the least, incorrect or non-operation, and at worst, destructive device failure. To avoid the problem of latchup, do not apply inputs to any pins before supply voltage is applied.

Input Voltages — These regulators accept working inputs of 1.4V to 18V. When power is applied, the rate-of-rise of the input may be hundreds of volts per microsecond. This is potentially harmful to the regulators, where internal operating currents are in the nanoampere range. The 0.047μF capacitor on the device side of the switch will limit inputs to a safe level around 2V/μs. Use of this capacitor is suggested in all applications. In severe rate-of-rise cases, it may be advisable to use an RC network on the SHutDown pin to delay output turn-on. Battery charging surges, transients, and assorted noise signals should be kept from the regulators by RC filtering, zener protection, or even fusing.

Output Voltages — The resistor divider R₂/R₁ is used to scale the reference voltage, V_{SET}, to the desired output using the formula $V_{OUT} = (1 + R_2/R_1) V_{SET}$. In the ICL7664, V_{IN} and V_{SET} are negative, so V_{OUT} will also be negative. Suitable arrangements of these resistors, using a potentiometer, enables exact values for V_{OUT} to be obtained. Because of the low leakage current of the V_{SET} terminal, these resistors can be tens of megohms for minimum additional quiescent drain current. However, some load current is required for proper operation, so for extremely low-drain applications it is necessary to draw at least 1μA. This can include the current for R₂ and R₁.

Output voltages up to nearly the V_{IN} supply may be obtained at low load currents, while the low limit is the reference voltage. The minimum input-output differential in each regulator is obtained using the V_{OUT1} terminal.

Output Currents — For the ICL7663, low output currents of less than 5mA are obtained with the least input-output differential from the V_{OUT1} terminal (connect V_{OUT2} to V_{OUT1}). Either output may be used on the ICL7664, with the unused output connected to V_{IN}. Where higher currents are needed, use V_{OUT2} on the ICL7663 (V_{OUT1} should be left open in this case) and parallel V_{OUT1} and V_{OUT2} on the ICL7664.

High output currents can be obtained only as far as package dissipation allows. It is strongly recommended that output current-limit sensing be used in such cases.

Current-Limit Sensing — The on-chip comparator (C in the block diagrams) permits shutdown of the regulator output in the event of excessive current drain. As the test circuits show, a current-limiting resistor, R_{CL}, is placed in series with V_{OUT2}, and the SENSE terminal is connected to the load side of R_{CL}. When the current through R_{CL} is high enough to produce a voltage drop equal to V_{CL} (0.7V for ICL7663, 0.35V for ICL7664) the voltage feedback is bypassed and the regulator output will be limited to this current. Therefore, when the maximum load current (I_{LOAD}) is determined, simply divide V_{CL} by I_{LOAD} to obtain the value for R_{CL}.

Logic-Controllable Shutdown — When equipment is not needed continuously (e.g., in remote data-acquisition systems), it is desirable to eliminate its drain on the system until it is required. This usually means switches, with their unreliable contacts. Instead, the ICL7663 and ICL7664 can be shut down by a logic signal, leaving only I_Q (under 4μA) as a drain on the power source. Since this pin must not be left open, it should be tied to ground if not needed. A voltage of less than 0.3V for the ICL7663, and greater than

–0.3V for the ICL7664 will keep the regulator ON, and a voltage level of more than 1.4V but less than V_{IN} for the ICL7663, and less than –1.4V but not less than V_{IN} for the ICL7664 control will turn the outputs OFF. If there is a possibility that the control signal could exceed the regulator input (V_{IN} or V_{IN}), the current from this signal should be limited to 100μA maximum by a high-value (1MΩ) series resistor. This situation may occur when the logic signal originates from a system powered separately from that of the regulator.

Additional Circuit Precautions — These regulators have poor rejection of voltage fluctuations from AC sources above 10Hz or so. To prevent the output from responding (where this might be a problem), a reservoir capacitor across the load is advised. The value of this capacitor is chosen so that the regulated output voltage reaches 90% of its final value in 20ms. From

$$I = C \frac{\Delta V}{\Delta t}, C = I_{OUT} \frac{(20 \times 10^{-3})}{0.9 V_{OUT}} = 0.022 \frac{I_{OUT}}{V_{OUT}}$$

In addition, where such a capacitor is used, a current-limiting resistor is also suggested (see "Current-Limit Sensing").

Producing Output Voltages With Negative Temperature Coefficients — The ICL7663 has an additional output (not present on the ICL7664) which is 0.9V relative to GND and has a tempco of +2.5mV/°C. By applying this voltage to the inverting input of amplifier A (i.e., the V_{SET} pin), output voltages having negative TC may be produced. The TC of the output voltage is controlled by the R₂/R₃ ratio (see Figure 4 and its design equations).

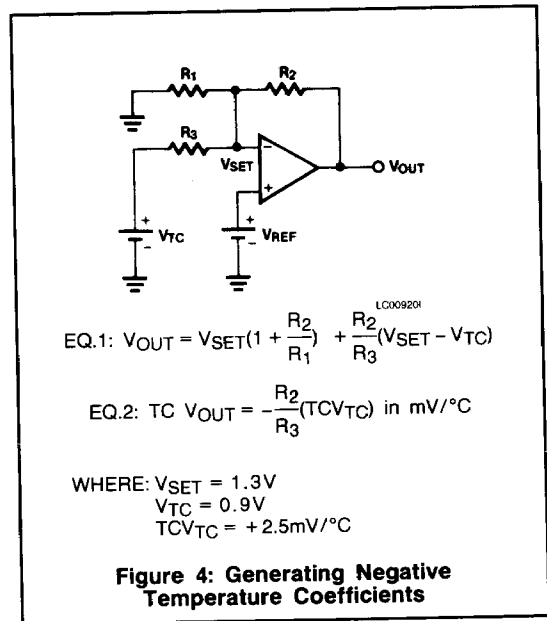

APPLICATIONS

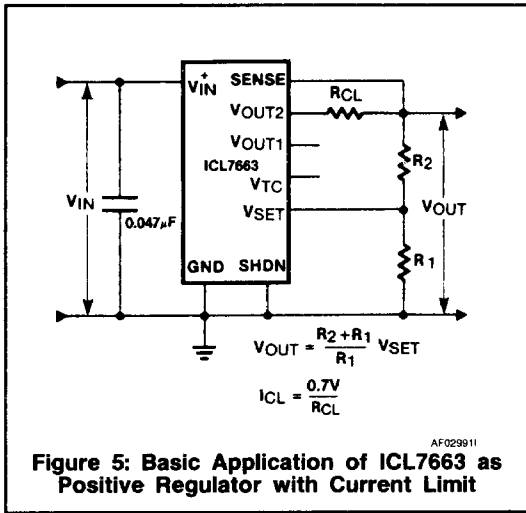

Figure 5: Basic Application of ICL7663 as Positive Regulator with Current Limit

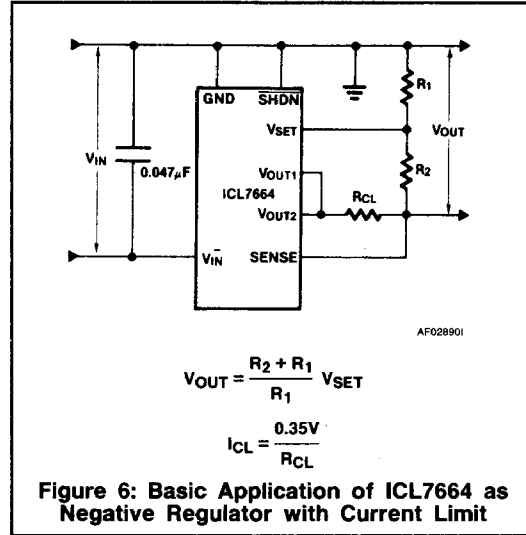

Figure 6: Basic Application of ICL7664 as Negative Regulator with Current Limit

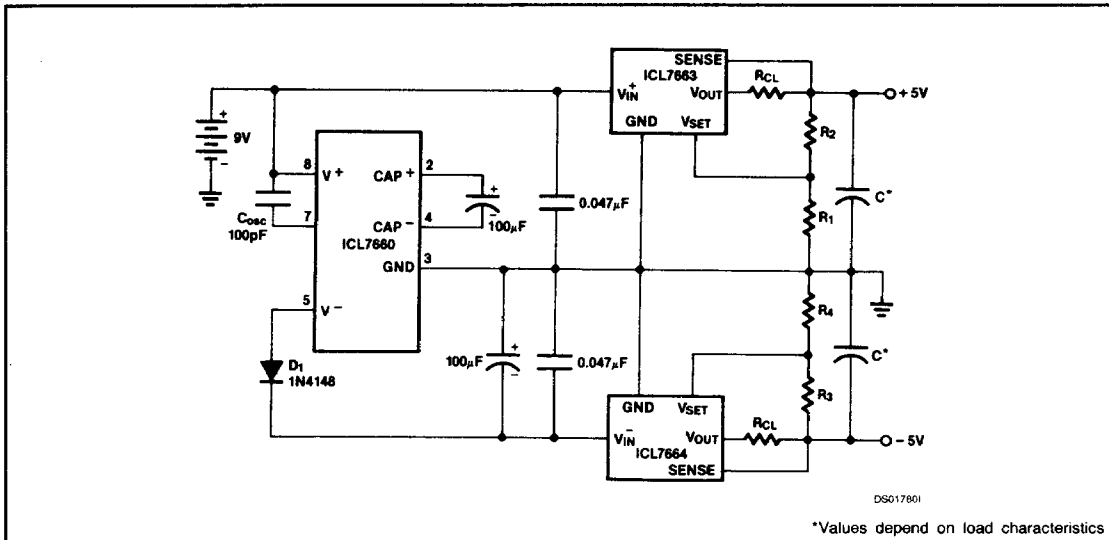

Figure 7: Generating regulated split supplies from a single supply.

The oscillation frequency of the ICL7660 is reduced by the external oscillator capacitor, so that it inverts the battery voltage more efficiently.

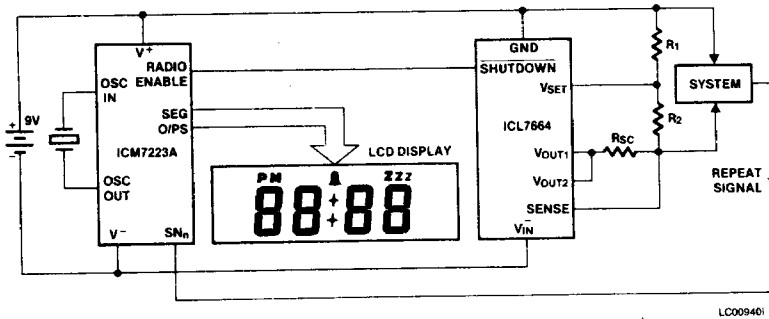

Figure 8: Once a Day System.

LC009401

This circuit will turn on a regulated supply to a system for one minute every day, via the SHUTDOWN pin on the ICL7664, and under control of the ICM7223A Alarm Clock circuit. If the system decides it needs another one minute activation, pulling the REPEAT line to V+ (GND) during one activation will trigger a subsequent activation after a snooze interval set by the choice of SN pins (2 mins shown). Alternatively, activation of the Sleep timer, without pause, can be achieved. See ICM7223A data sheet for details.

ICL7663B/4B ADDENDUM TO THE ICL7663/4 DATASHEET

This Addendum to the standard ICL7663/4 datasheet describes changes and/or modifications to the DC Operating characteristics applicable to the ICL7663B/ICL7664B devices. The following table indicates those limits to which the ICL7663B/ICL7664B is tested and/or guaranteed operational.

ICL7663B POSITIVE REGULATOR ORDERING INFORMATION

POSITIVE REGULATOR		
ICL7663B/D	—	DICE
ICL7663BCBA	0°C to 70°C	8-pin S.O.I.C.
ICL7663BCJA	0°C to 70°C	8-pin CERPDP
ICL7663BCPA	0°C to 70°C	8-pin MiniDIP
ICL7663BCTV	0°C to 70°C	TO-99

ABSOLUTE MAXIMUM RATINGS ICL7663B

Input Supply Voltage +12V
 Any Input or Output Voltage (Note 1) Terminals 1, 2, 3, 4, 5, 6, 7)(GND -0.3V) to (V_{IN}⁺ +0.3V)
 Output Source Current
 (Terminal 2) 50mA
 (Terminal 3) 25mA

Output Sinking Current (Terminal 7) -10mA
 Power Dissipation (Note 2)
 MiniDIP 200mW
 TO-99 Can 300mW

Stresses above those listed under "Absolute Maximum Ratings" may cause permanent damage to the device. These are stress ratings only and functional operation of the device at these or any other conditions above those indicated in the operational sections of the specifications is not implied. Exposure to absolute maximum rating conditions for extended periods may affect device reliability.

ICL7663B OPERATING CHARACTERISTICS V_{IN}⁺ = 9V, V_{OUT} = 5V, T_A = +25°C, unless otherwise specified.

SYMBOL	PARAMETER	TEST CONDITIONS	LIMITS			UNIT
			MIN	TYP	MAX	
V _{IN} ⁺	Input Voltage	T _A = +25°C 20°C ≤ T _A ≤ +70°C	1.5 1.6		10 10	V
I _Q	Quiescent Current	{ R _L = ∞ { 1.4V ≤ V _{OUT} ≤ 8.5V }		3.5	10	μA
V _{SET}	Reference Voltage		1.2	1.3	1.4	V
$\frac{\Delta V_{SET}}{\Delta T}$	Temperature Coefficient	8.5V < V _{IN} ⁺ < 9V		±200		ppm
$\frac{\Delta V_{SET}}{V_{SET} \Delta V_{IN}}$	Line Regulation	2V < V _{IN} ⁺ < 9V		0.03		%/V
I _{SET}	V _{SET} Input Current			±0.01	10	nA
I _{SHDN}	Shutdown Input Current			±0.01	10	nA
V _{SHDN}	Shutdown Input Voltage	V _{SHDNHI} : Both V _{OUT} Disabled V _{SHDNLO} : Both V _{OUT} Enabled	1.4		0.3	V
I _{SENSE}	Sense Pin Input Current			0.01	10	nA
V _{CL}	Sense Pin Input Threshold Voltage	V _{CL} = V _{OUT2} - V _{SENSE} (Current-Limit Threshold)		0.7		V
R _{SAT}	Input-Output Saturation Resistance (Note 3)	V _{IN} ⁺ = 2V V _{IN} ⁺ = 9V		200 70		Ω
$\frac{\Delta V_{OUT}}{\Delta I_{OUT}}$	Load Regulation	ΔI _{OUT1} = 100μA @ V _{OUT1} = 5V ΔI _{OUT2} = 10mA @ V _{OUT2} = 5V		2 1		Ω
I _{OUT2}	Available Output Current (V _{OUT2})	V _{IN} ⁺ = 3V V _{OUT} = V _{SET} V _{IN} ⁺ = 9V V _{OUT} = 5V	10 25			mA
V _{TC}	Negative-Tempco Output (Note 4)	Open-Circuit Voltage		0.9		V
I _{TC}		Maximum Sink Current	0	8	2	mA

ICL7663/7664

ICL7663B OPERATING CHARACTERISTICS (CONT.)

SYMBOL	PARAMETER	TEST CONDITIONS	LIMITS			UNIT
			MIN	TYP	MAX	
$\frac{\Delta V_{TC}}{\Delta T}$	Temperature Coefficient	Open Circuit		+2.5		mV/°C
$I_{L(min)}$	Minimum Load Current	(Includes V_{SET} Divider)			1	μA

- NOTES:**
1. Connecting any terminal to voltages greater than ($V_{IN} + 0.3V$) or less than ($GND - 0.3V$) may cause destructive device latchup. It is recommended that no inputs from sources operating on external power supplies be applied prior to ICL7663B power-up.
 2. Derate linearly above 50°C at 5mW/°C for minidip and 7.5mW/°C for TO-99 can.
 3. This parameter refers to the saturation resistance of the MOS pass transistor. The minimum input-output voltage differential at low current (under 5mA), can be determined by multiplying the load current (including set resistor current, but not quiescent current) by this resistance.
 4. This output has a positive temperature coefficient. Using it in combination with the inverting input of the regulator at V_{SET} , a negative coefficient results in the output voltage. See Figure 3 for details. Pin will not source current.

ICL7663/7664

ICL7664B NEGATIVE REGULATOR

ORDERING INFORMATION

Negative Regulator		
ICL7664BCPA	0 to +70°C	8-pin MiniDIP
ICL7664BCTV	0 to +70°C	TO-99
ICL7664B/D	—	DICE
ICL7664BCBA	0 to +70°C	8-pin S.O.I.C
ICL7664BCJA	0 to +70°C	8-pin CERDIP

ABSOLUTE MAXIMUM RATINGS ICL7664B

Input Supply Voltage	- 12V
Any Input or Output Voltage (Note 1)	(Terminal 1,7) (GND + 0.3V to $V_{IN} - 0.3V$)
Output Source Current	(Terminal 1,7) - 25mA
Power Dissipation (Note 2)	
MiniDIP	200mW
TO-99	300mW

Stresses above those listed under "Absolute Maximum Ratings" may cause permanent damage to the device. These are stress ratings only and functional operation of the device at these or any other conditions above those indicated in the operational sections of the specifications is not implied. Exposure to absolute maximum rating conditions for extended periods may affect device reliability.

ICL7664B OPERATING CHARACTERISTICS $V_{IN} = 9V$, $V_{OUT} = -5V$, $T_A = +25^\circ C$, unless otherwise specified.

SYMBOL	PARAMETER	TEST CONDITIONS	LIMITS			UNIT
			MIN	TYP	MAX	
V_{IN}	Input Voltage	$T_A = +25^\circ C$ $0 \leq T_A \leq +70^\circ C$	-1.5 -1.6		-10 -10	V
I_Q	Quiescent Current	$\left\{ \begin{array}{l} R_L = \infty \\ -1.4V \leq V_{OUT} \leq -8.5V \end{array} \right\}$	3.5	10	μA	
V_{SET}	Reference Voltage		-1.2	-1.3	-1.4	V
$\frac{\Delta V_{SET}}{\Delta T}$	Temperature Coefficient	$-8.5V < V_{IN} < -9V$		± 200		ppm
$\frac{\Delta V_{SET}}{V_{SET} \Delta V_{IN}}$	Line Regulation	$-2V < V_{IN} < -9V$		0.03		%/V
I_{SET}	V_{SET} Input Current			± 0.01	10	nA
I_{SHDN}	Shutdown Input Current			± 0.01	10	nA
V_{SHDN}	Shutdown Input Voltage	V_{SHDNHI} : Both V_{OUT} Disabled V_{SHDNLO} : Both V_{OUT} Enabled	-0.3		-1.4	V
I_{SENSE}	Sense Pin Input Current			0.01	10	nA
V_{CL}	Sense Pin Input Threshold Voltage	$V_{CL} = V_{OUT2} - V_{SENSE}$ (Current-Limit Threshold)		-0.35		V
R_{SAT}	Input-Output Saturation Resistance (Note 3)	$V_{IN} = 2V$ $V_{IN} = 9V$		150 40		Ω
$\frac{\Delta V_{OUT}}{\Delta I_{OUT}}$	Load Regulation	$\Delta I_{OUT1} = 100\mu A$ @ $\Delta I_{OUT} = -5V$		2		Ω
I_{OUT}	Output Current V_{OUT1} or V_{OUT2}	$V_{IN} = 3V$ $V_{OUT} = V_{SET}$ $V_{IN} = 9V$ $V_{OUT} = -5V$		-2 -20		mA
$I_{L(min)}$	Minimum Load Current (Includes V_{SET} Divider)				1	μA

- NOTES:**
1. Connecting any terminal to voltages greater than (GND + 0.3V) or less than ($V_{IN} - 0.3V$) may cause destructive device latchup. It is recommended that no inputs from sources operating on external power supplies be applied prior to ICL7664B power-up.
 2. Derate linearly above 50°C at 5mW/°C for minidip and 7.5mW/°C for TO-99 can.
 3. This parameter refers to the saturation resistance of the MOS pass transistor. The minimum input-output voltage differential can be determined by multiplying the load current (including set resistor current, but not quiescent current) by this resistance.