

National Semiconductor is now part of
Texas Instruments.

Search <http://www.ti.com/> for the latest technical
information and details on our current products and services.

LM5009

150 mA, 100V Step-Down Switching Regulator

General Description

The LM5009 Step Down Switching Regulator features all of the functions needed to implement a low cost, efficient, Buck bias regulator. This device is capable of driving a 150 mA load current from a 9.5V to 95V input source. The switching frequency can exceed 600 kHz, depending on the input and output voltages. The output voltage may be set from 2.5V to 85V. This high voltage regulator contains an N-Channel buck switch and internal startup regulator. The device is easy to implement and is provided in the MSOP-8 and the thermally enhanced LLP-8 packages. The LM5009 is a well suited alternative to a high voltage monolithic or discrete linear solution where the power loss becomes unacceptable. The regulator's operation is based on a control scheme using an ON time inversely proportional to VIN. This feature allows the operating frequency to remain relatively constant over load and input voltage variations. The control scheme requires no loop compensation, resulting in an ultra-fast transient response. An intelligent current limit is implemented with forced OFF time, which is inversely proportional to Vout. This scheme ensures short circuit protection while providing minimum foldback. Other features include: Thermal Shutdown, Vcc under-voltage lockout, Gate drive under-voltage lockout, and Maximum Duty Cycle limiter.

Features

- Integrated N-Channel MOSFET
- Guaranteed 150 mA output current capability
- Ultra-Fast Transient Response
- No loop compensation required
- Vin feed forward provides constant operating frequency
- Switching frequency can exceed 600 kHz
- Highly efficient operation
- 2% accurate 2.5V feedback from -40°C to 125°C
- Internal startup regulator
- Intelligent current limit protection
- External shutdown control
- Thermal shutdown
- MSOP-8 and thermally enhanced LLP packages

Typical Applications

- Heat sink eliminator for classic linear regulator applications
- 12V, 24V, 36V, and 48V rectified AC systems
- 42V Automotive
- Non-isolated AC mains charge coupled supplies
- LED Current Source

Package

- MSOP - 8
- LLP - 8 (4mm x 4mm)

Typical Application Circuit

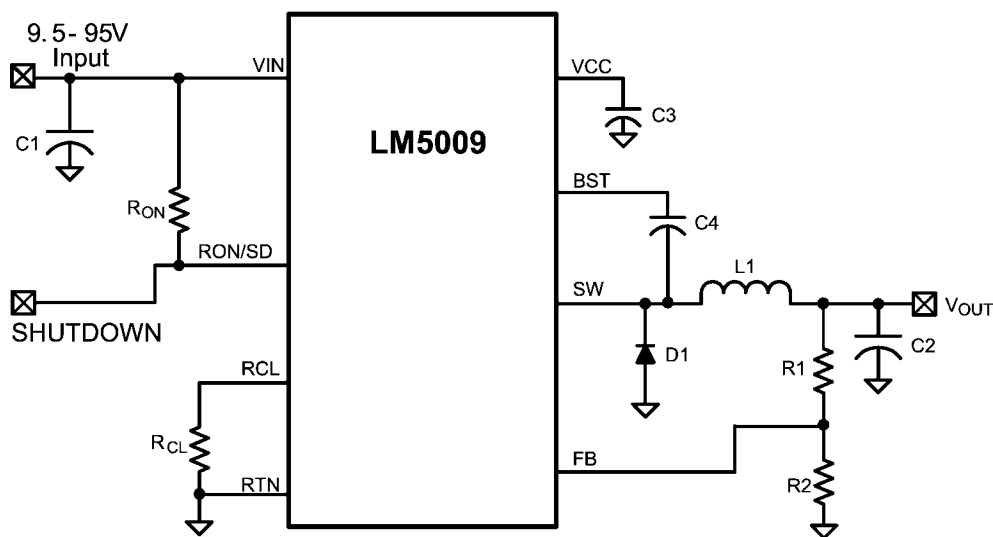

Basic Stepdown Regulator

20165828

Connection Diagram

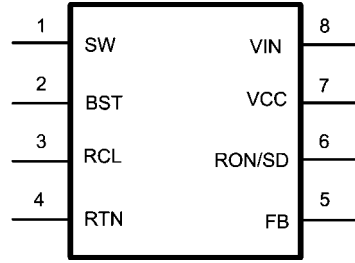

8-Lead MSOP, LLP

20165802

Ordering Information

Order Number	Package Type	NSC Package Drawing	Supplied As
LM5009MM	MSOP-8	MUA08A	1000 Units on Tape and Reel
LM5009MMX	MSOP-8	MUA08A	3500 Units per Reel
LM5009SDC	LLP-8	SDC08B	1000 Units on Tape and Reel
LM5009SDCX	LLP-8	SDC08B	4500 Units per Reel

Pin Descriptions

Pin	Name	Description	Application Information
1	SW	Switching output	Power switching output. Connect to the inductor, recirculating diode, and bootstrap capacitor.
2	BST	Boost Pin	An external capacitor is required between the BST and the SW pins. A 0.022 μF ceramic capacitor is recommended. An internal diode charges the capacitor from V_{CC} .
3	RCL	Current Limit off-time set pin	A resistor between this pin and RTN sets the off-time when current limit is detected. The off-time is preset to 35 μs if $\text{FB} = 0\text{V}$.
4	RTN	Ground pin	Ground for the entire circuit.
5	FB	Feedback input from Regulated Output	This pin is connected to the inverting input of the internal regulation comparator. The regulation threshold is 2.5V.
6	RON/SD	On-time set pin	A resistor between this pin and VIN sets the switch on-time as a function of V_{IN} . The minimum recommended on-time is 250ns at the maximum input voltage. This pin can be used for remote shutdown.
7	VCC	Output from the internal high voltage startup regulator. Regulated at 7.0V.	If an auxiliary voltage is available to raise the voltage on this pin above the regulation setpoint (7V), the internal series pass regulator will shutdown, reducing the IC power dissipation. Do not exceed 14V. This voltage provides gate drive power for the internal Buck switch. An internal diode is provided between this pin and the BST pin. A local 0.1 μF decoupling capacitor is required.
8	VIN	Input voltage	Recommended operating range: 9.5V to 95V.
	EP	Exposed Pad (LLP Package only)	Exposed metal pad on the underside of the device. It is recommended to connect this to the PC board ground plane to aid in heat dissipation.

Absolute Maximum Ratings *(Note 1)*

If Military/Aerospace specified devices are required, please contact the National Semiconductor Sales Office/Distributors for availability and specifications.

V_{IN} to RTN	-0.3V to 100V
BST to RTN	-0.3V to 114V
SW to RTN (Steady State)	-1V
ESD Rating <i>(Note 4)</i>	
Human Body Model	2kV
BST to VCC	100V

BST to SW	14V
VCC to RTN	14V
All Other Inputs to RTN	-0.3 to 7V
For soldering specs see: www.national.com/ms/MS/MS=SOLDERING.pdf	
Storage Temperature Range	-65°C to +150°C

Operating Ratings *(Note 1)*

V_{IN}	9.5V to 95V
Operating Junction Temperature	-40°C to + 125°C

Electrical Characteristics

Limits in standard type are for $T_J = 25^\circ\text{C}$ only, and limits in boldface type apply over the junction temperature (T_J) range of -40°C to $+125^\circ\text{C}$. Minimum and Maximum limits are guaranteed through test, design, or statistical correlation. Typical values represent the most likely parametric norm at $T_J = 25^\circ\text{C}$, and are provided for reference purposes only. Unless otherwise stated, the following conditions apply: $V_{IN} = 48\text{V}$, $R_{ON} = 200\text{k}\Omega$. See *(Note 2)*

Symbol	Parameter	Conditions	Min	Typ	Max	Units
V_{CC} Supply						
V_{CC} Reg	V_{CC} Regulator Output		6.6	7	7.4	V
	V_{CC} Current Limit	<i>(Note 3)</i>		9.5		mA
	V_{CC} undervoltage Lockout Voltage (V_{CC} increasing)			6.3		V
	V_{CC} Undervoltage Hysteresis			200		mV
	V_{CC} UVLO Delay (filter)	100mV overdrive		10		μs
	I_{IN} Operating Current	Non-Switching, FB = 3V		485	675	μA
	I_{IN} Shutdown Current	$R_{ON}/SD = 0\text{V}$		76	150	μA
Switch Characteristics						
	Buck Switch $R_{ds(on)}$	$I_{TEST} = 200\text{mA}$, <i>(Note 5)</i>		2.0	4.4	Ω
	Gate Drive UVLO	$V_{BST} - V_{SW}$ Rising	3.4	4.5	5.5	V
	Gate Drive UVLO Hysteresis			430		mV
Current Limit						
	Current Limit Threshold		0.25	0.31	0.37	A
	Current Limit Response Time	I_{switch} Overdrive = 0.1A Time to Switch Off		400		ns
	OFF time generator (test 1)	FB=0V, $R_{CL} = 100\text{K}$		35		μs
	OFF time generator (test 2)	FB=2.3V, $R_{CL} = 100\text{K}$		2.56		μs
On Time Generator						
	T_{ON-1}	$V_{in} = 10\text{V}$ $R_{on} = 200\text{K}$	2.15	2.77	3.5	μs
	T_{ON-2}	$V_{in} = 95\text{V}$ $R_{on} = 200\text{K}$	200	300	420	ns
	Remote Shutdown Threshold	Rising	0.40	0.70	1.05	V
	Remote Shutdown Hysteresis			35		mV

Symbol	Parameter	Conditions	Min	Typ	Max	Units
Minimum Off Time						
	Minimum Off Timer	FB = 0V		300		ns
Regulation and OV Comparators						
	FB Reference Threshold	Internal reference Trip point for switch ON	2.445	2.5	2.550	V
	FB Over-Voltage Threshold	Trip point for switch OFF		2.875		V
	FB Bias Current			1		nA
Thermal Shutdown						
Tsd	Thermal Shutdown Temp.			165		°C
	Thermal Shutdown Hysteresis			25		°C
Thermal Resistance						
θ_{JA}	Junction to Ambient	MUA Package		200		°C/W
		SDC Package		40		°C/W

Note 1: Absolute Maximum Ratings are limits beyond which damage to the device may occur. Operating Ratings are conditions under which operation of the device is intended to be functional. For guaranteed specifications and test conditions, see the Electrical Characteristics.

Note 2: All limits are guaranteed. All electrical characteristics having room temperature limits are tested during production with $T_A = T_J = 25^\circ\text{C}$. All hot and cold limits are guaranteed by correlating the electrical characteristics to process and temperature variations and applying statistical process control.

Note 3: The V_{CC} output is intended as a self bias for the internal gate drive power and control circuits. Device thermal limitations limit external loading.

Note 4: The human body model is a 100pF capacitor discharged through a 1.5k Ω resistor into each pin.

Note 5: For devices procured in the LLP-8 package the $R_{ds(on)}$ limits are guaranteed by design characterization data only.

Typical Performance Characteristics

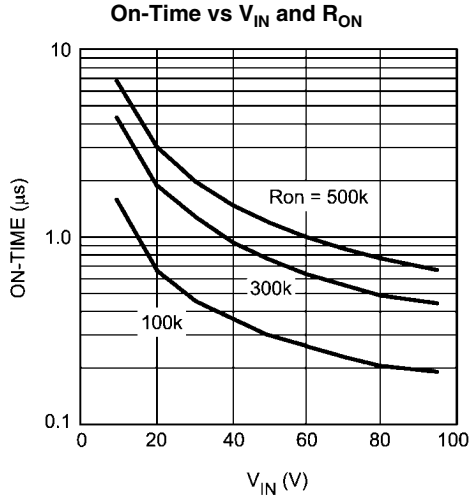

20165809

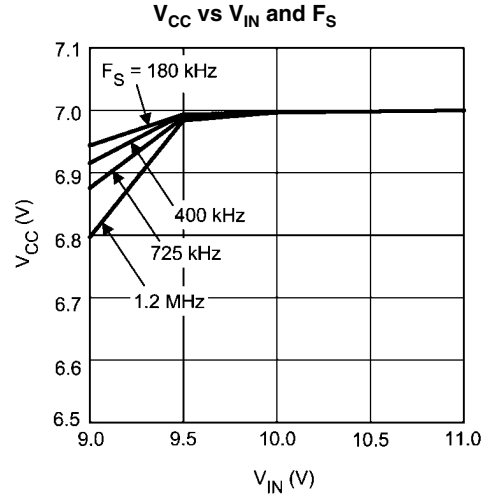

20165829

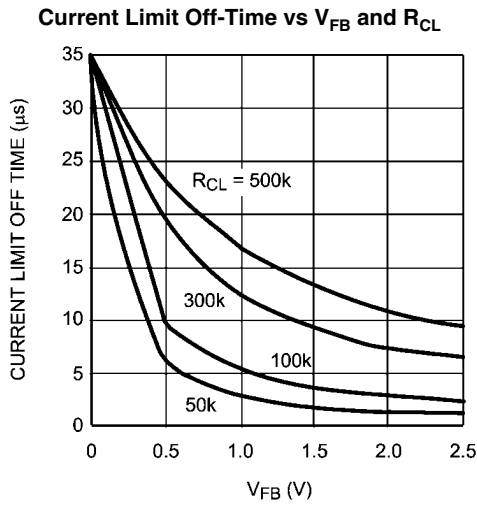

20165812

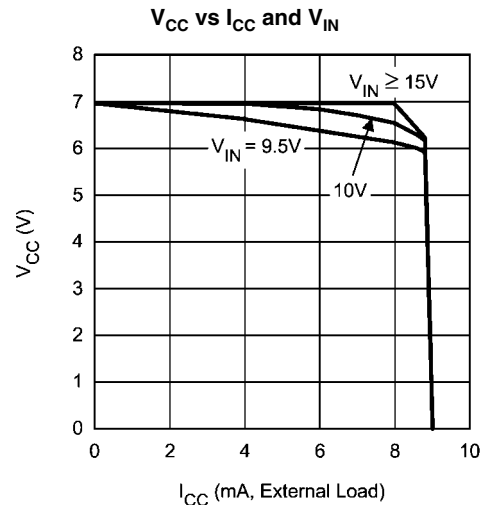

20165830

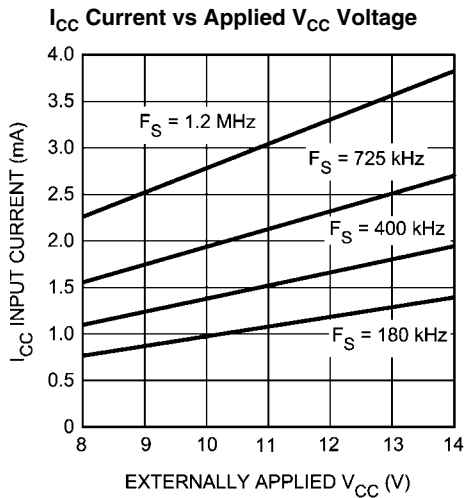

20165811

Typical Application Circuit and Block Diagram

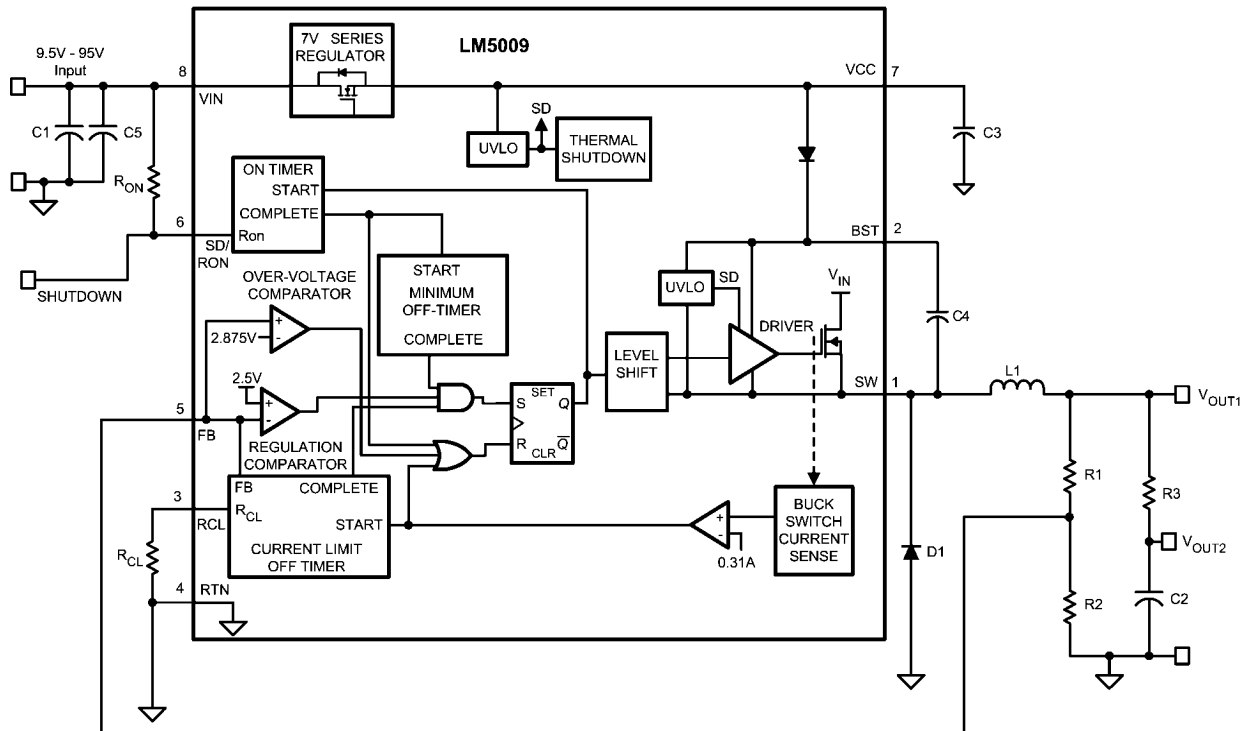

20165801

FIGURE 1.

Functional Description

The LM5009 Step Down Switching Regulator features all the functions needed to implement a low cost, efficient, Buck bias power converter. This high voltage regulator contains a 100 V N-Channel Buck Switch, is easy to implement and is provided in the MSOP-8 and the thermally enhanced LLP-8 packages. The regulator is based on a control scheme using an on-time inversely proportional to V_{IN} . The control scheme requires no loop compensation. Current limit is implemented with forced off-time, which is inversely proportional to V_{OUT} . This scheme ensures short circuit protection while providing minimum foldback. The Functional Block Diagram of the LM5009 is shown in *Figure 1*.

The LM5009 can be applied in numerous applications to efficiently regulate down higher voltages. This regulator is well suited for 48 Volt Telecom and the 42V Automotive power bus ranges. Additional features include: Thermal Shutdown, V_{CC} under-voltage lockout, Gate drive under-voltage lockout, Max Duty Cycle limit timer and the intelligent current limit off timer.

Control Circuit Overview

The LM5009 is a Buck DC-DC regulator that uses a control scheme in which the on-time varies inversely with line voltage (V_{IN}). Control is based on a comparator and the on-time one-shot, with the output voltage feedback (FB) compared to an internal reference (2.5V). If the FB level is below the reference the buck switch is turned on for a fixed time determined by the line voltage and a programming resistor (R_{ON}). Following the ON period the switch will remain off for at least the minimum off-timer period of 300 ns. If FB is still below the reference at

that time the switch will turn on again for another on-time period. This will continue until regulation is achieved, at which time the off-time increases based on the required duty cycle.

The LM5009 operates in discontinuous conduction mode at light load currents, and continuous conduction mode at heavy load current. In discontinuous conduction mode, current through the output inductor starts at zero and ramps up to a peak during the on-time, then ramps back to zero before the end of the off-time. The next on-time period starts when the voltage at FB falls below the internal reference - until then the inductor current remains zero. In this mode the operating frequency is lower than in continuous conduction mode, and varies with load current. Therefore at light loads the conversion efficiency is maintained, since the switching losses reduce with the reduction in load and frequency. The discontinuous operating frequency can be calculated as follows:

$$F = \frac{V_{OUT}^2 \times L \times 1.28 \times 10^{20}}{R_L \times (R_{ON})^2}$$

where R_L = the load resistance

In continuous conduction mode, current flows continuously through the inductor and never ramps down to zero. In this mode the operating frequency is greater than the discontinuous mode frequency and remains relatively constant with load and line variations. The approximate continuous mode operating frequency can be calculated as follows:

$$F = \frac{V_{OUT}}{1.25 \times 10^{-10} \times R_{ON}} \quad (1)$$

The output voltage (V_{OUT}) is programmed by two external resistors as shown in [Figure 1](#). The regulation point is calculated as follows:

$$V_{OUT} = 2.5 \times (R1 + R2) / R2$$

This regulator regulates the output voltage based on ripple voltage at the feedback input, requiring a minimum amount of ESR for the output capacitor C2. A minimum of 25mV of ripple voltage at the feedback pin (FB) is required for the LM5009. In cases where the capacitor ESR is too small, additional series resistance may be required (R3 in [Figure 1](#)).

For applications where lower output voltage ripple is required the output can be taken directly from a low ESR output capacitor, as shown in [Figure 2](#). However, R3 slightly degrades the load regulation.

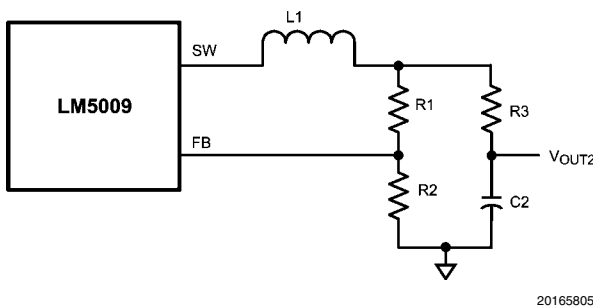

FIGURE 2. Low Ripple Output Configuration

High Voltage Start-Up Regulator

The LM5009 contains an internal high voltage startup regulator. The input pin (V_{IN}) can be connected directly to line voltages up to 95 Volts, with transient capability to 100 volts. The regulator is internally current limited at 9.5mA. Upon power up, the regulator sources current into the external capacitor at VCC (C3). When the voltage on the VCC pin reaches the under-voltage lockout threshold of 6.3V, the buck switch is enabled.

In applications involving a high value for V_{IN} , where power dissipation in the V_{CC} regulator is a concern, an auxiliary voltage can be diode connected to the VCC pin. Setting the voltage between 8V and 14V shuts off the internal regulator, reducing internal power dissipation. See [Figure 3](#). The current required into the VCC pin is shown in the Typical Performance Characteristics.

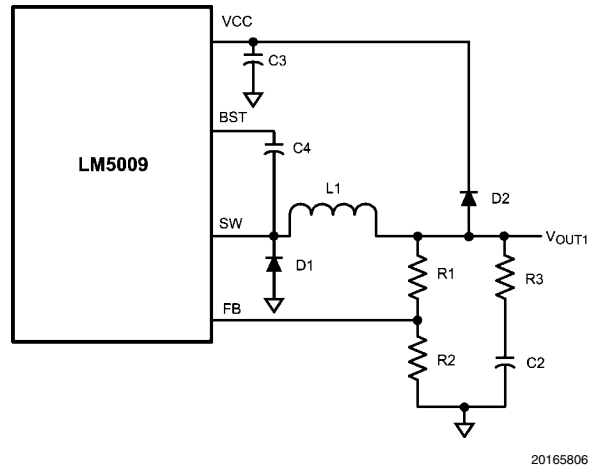

FIGURE 3. Self Biased Configuration

Regulation Comparator

The feedback voltage at FB is compared to an internal 2.5V reference. In normal operation (the output voltage is regulated), an on-time period is initiated when the voltage at FB falls below 2.5V. The buck switch will stay on for the programmed on-time, causing the FB voltage to rise above 2.5V. After the on-time period, the buck switch will stay off until the FB voltage again falls below 2.5V. During start-up, the FB voltage will be below 2.5V at the end of each on-time, resulting in the minimum off-time. Bias current at the FB pin is less than 5 nA over temperature.

Over-Voltage Comparator

The feedback voltage at FB is compared to an internal 2.875V reference. If the voltage at FB rises above 2.875V the on-time pulse is immediately terminated. This condition can occur if the input voltage, or the output load, change suddenly. The buck switch will not turn on again until the voltage at FB falls below 2.5V.

ON-Time Generator and Shutdown

The on-time for the LM5009 is determined by the R_{ON} resistor, and is inversely proportional to the input voltage (V_{in}), resulting in a nearly constant frequency as V_{in} is varied over its range. The on-time equation is:

$$T_{ON} = 1.25 \times 10^{-10} \times R_{ON} / V_{IN} \quad (2)$$

R_{ON} should be selected for a minimum on-time (at maximum V_{IN}) greater than 250 ns, for proper current limit operation. This requirement limits the maximum frequency for each application, depending on V_{IN} and V_{OUT} .

The LM5009 can be remotely disabled by taking the R_{ON}/SD pin to ground. See [Figure 4](#). The voltage at the R_{ON}/SD pin is between 1.7V and 5V, depending on V_{in} and the value of the R_{ON} resistor.

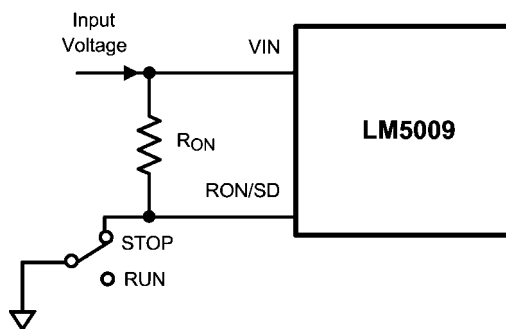

20165807

FIGURE 4. Shutdown Implementation

Current Limit

The LM5009 contains an intelligent current limit OFF timer. If the current in the Buck switch exceeds 0.31A the present cycle is immediately terminated, and a non-resettable OFF timer is initiated. The length of off-time is controlled by an external resistor (R_{CL}) and the FB voltage. When $FB = 0V$, a maximum off-time is required, and the time is preset to 35 μ s. This condition occurs when the output is shorted, and during the initial part of start-up. This amount of time ensures safe short circuit operation up to the maximum input voltage of 95V. In cases of overload where the FB voltage is above zero volts (not a short circuit) the current limit off-time will be less than 35 μ s. Reducing the off-time during less severe overloads reduces the amount of foldback, recovery time, and the start-up time. The off-time is calculated from the following equation:

$$T_{OFF} = \frac{10^{-5}}{0.285 + \frac{V_{FB}}{(6.35 \times 10^{-6} \times R_{CL})}} \quad (3)$$

The current limit sensing circuit is blanked for the first 50-70ns of each on-time so it is not falsely tripped by the current surge which occurs at turn-on. The current surge is required by the re-circulating diode (D1) for its turn-off recovery.

N - Channel Buck Switch and Driver

The LM5009 integrates an N-Channel buck switch and associated floating high voltage gate driver. The gate driver circuit works in conjunction with an external bootstrap capacitor and an internal high voltage diode. A 0.022 μ F ceramic capacitor (C4) connected between the BST pin and SW pin provides the voltage to the driver during the on-time.

During each off-time, the SW pin is at approximately -1V, and the bootstrap capacitor charges from V_{CC} through the internal diode. The minimum OFF timer ensures a minimum time each cycle to recharge the bootstrap capacitor.

An external re-circulating diode (D1) carries the inductor current after the internal buck switch turns off. This diode should be of the Ultra-fast or Schottky type to minimize turn-on losses and current over-shoot.

Thermal Protection

The LM5009 should be operated so the junction temperature does not exceed 125°C during normal operation. An internal Thermal Shutdown circuit is provided to protect the LM5009 in the event of a higher than normal junction temperature.

When activated, typically at 165°C, the controller is forced into a low power reset state, disabling the buck switch. This feature prevents catastrophic failures from accidental device overheating. When the junction temperature reduces below 140°C (typical hysteresis = 25°C), the buck switch is enabled, and normal operation is resumed.

Applications Information

SELECTION OF EXTERNAL COMPONENTS

A guide for determining the component values will be illustrated with a design example. Refer to [Figure 1](#). The following steps will configure the LM5009 for:

- Input voltage range (V_{IN}): 12V to 90V
- Output voltage (V_{OUT1}): 10V
- Load current (for continuous conduction mode): 100mA to 150mA

R1 and R2: From [Figure 1](#), $V_{OUT1} = V_{FB} \times (R1 + R2) / R2$, and since $V_{FB} = 2.5V$, the ratio of R1 to R2 calculates as 3:1. Standard values of 3.01 k Ω (R1) and 1.00 k Ω (R2) are chosen. Other values could be used as long as the 3:1 ratio is maintained. The selected values, however, provide a small amount of output loading (2.5 mA) in the event the main load is disconnected. This allows the circuit to maintain regulation until the main load is reconnected.

F_s and R_{ON}: Unless the application requires a specific frequency, the choice of frequency is generally a compromise since it affects the size of L1 and C2, and the switching losses. The maximum allowed frequency, based on a minimum on-time of 250 ns, is calculated from:

$$F_{MAX} = V_{OUT} / (V_{INMAX} \times 250 \text{ ns})$$

For this exercise, $F_{max} = 444$ kHz. From equation 1, R_{ON} calculates to 180 k Ω . A standard value 237 k Ω resistor will be used to allow for tolerances in equation 1, resulting in a nominal frequency of 337 kHz.

L1: The main parameter affected by the inductor is the output current ripple amplitude. The choice of inductor value therefore depends on both the minimum and maximum load currents, keeping in mind that the maximum ripple current occurs at maximum V_{IN} .

a) **Minimum load current:** To maintain continuous conduction at minimum I_o (100 mA), the ripple amplitude (I_{OR}) must be less than 200 mA p-p so the lower peak of the waveform does not reach zero. L1 is calculated using the following equation:

$$L1 = \frac{V_{OUT1} \times (V_{IN} - V_{OUT1})}{I_{OR} \times F_s \times V_{IN}}$$

At $V_{in} = 90V$, $L1(\min)$ calculates to $132 \mu H$. The next larger standard value ($150 \mu H$) is chosen and with this value I_{OR} calculates to 176 mA p-p at $V_{in} = 90V$, and 33 mA p-p at $V_{in} = 12V$.

b) Maximum load current: At a load current of 150 mA , the peak of the ripple waveform must not reach the minimum guaranteed value of the LM5009's current limit threshold (250 mA). Therefore the ripple amplitude must be less than 200 mA p-p , which is already satisfied in the above calculation. With $L1 = 150 \mu H$, at maximum V_{in} and I_o , the peak of the ripple will be 238 mA . While $L1$ must carry this peak current without saturating or exceeding its temperature rating, it also must be capable of carrying the maximum guaranteed value of the LM5009's current limit threshold (370 mA) without saturating, since the current limit is reached during startup.

C3: The capacitor on the V_{CC} output provides not only noise filtering and stability, but also prevents false triggering of the V_{CC} UVLO at the buck switch on/off transitions. For this reason, $C3$ should be no smaller than $0.1 \mu F$.

C2, and R3: When selecting the output filter capacitor $C2$, the items to consider are ripple voltage due to its ESR, ripple voltage due to its capacitance, and the nature of the load.

a) ESR and R3: A low ESR for $C2$ is generally desirable so as to minimize power losses and heating within the capacitor. However, this regulator requires a minimum amount of ripple voltage at the feedback input for proper loop operation. For the LM5009 the minimum ripple required at pin 5 is 25 mV p-p , requiring a minimum ripple at V_{OUT1} of 100 mV . Since the minimum ripple current (at minimum V_{in}) is 33 mA p-p , the minimum ESR required at V_{OUT1} is 3Ω . Since quality capacitors for SMPS applications have an ESR considerably less than this, $R3$ is inserted as shown in Figure 1. $R3$'s value, along with $C2$'s ESR, must result in at least 25 mV p-p ripple at pin 5. Generally, $R3$ will be 0.5Ω to 5.0Ω .

b) Nature of the Load: The load can be connected to V_{OUT1} or V_{OUT2} . V_{OUT1} provides good regulation, but with a ripple voltage which ranges from 100 mV (@ $V_{in} = 12V$) to 580 mV (@ $V_{in} = 90V$). Alternatively, V_{OUT2} provides low ripple (3 mV to 13 mV) but lower regulation due to $R3$.

$C2$ should generally be no smaller than $3.3 \mu F$. Typically, its value is $10 \mu F$ to $20 \mu F$, with the optimum value determined by the load. If the load current is fairly constant, a small value suffices for $C2$. If the load current includes significant transients, a larger value is necessary. For each application, experimentation is needed to determine the optimum values for $R3$ and $C2$.

C) Ripple Reduction: The ripple amplitude at V_{OUT1} can be reduced by reducing $R3$, and adding a capacitor across $R1$ so as to transfer the ripple at V_{OUT1} directly to the FB pin, without attenuation. The new value of $R3$ is calculated from:

$$R3 = 25 \text{ mV} / I_{OR(\min)}$$

where $I_{OR(\min)}$ is the minimum ripple current amplitude - 33 mA p-p in this example. The added capacitor's value is calculated from:

$$C = T_{ON(\max)} / (R1 // R2)$$

where $T_{ON(\max)}$ is the maximum on-time (at minimum V_{in}). The selected capacitor should be larger than the value calculated above.

R_{CL}: When a current limit condition is detected, the minimum off-time set by this resistor must be greater than the maximum normal off-time which occurs at maximum V_{in} . Using equation 2, the minimum on-time is $0.329 \mu s$, yielding a maximum off-time of $2.63 \mu s$. This is increased by 82 ns (to $2.72 \mu s$) due to a $\pm 25\%$ tolerance of the on-time. This value is then increased to allow for:

The response time of the current limit detection loop (400 ns),

The off-time determined by equation 3 has a $\pm 25\%$ tolerance,

$$t_{OFFCL(\min)} = (2.72 \mu s \times 1.25) + 0.4 \mu s = 3.8 \mu s$$

Using equation 3, R_{CL} calculates to $167 \text{ k}\Omega$ (at $V_{FB} = 2.5V$). The closest standard value is $169 \text{ k}\Omega$.

D1: The important parameters are reverse recovery time and forward voltage. The reverse recovery time determines how long the reverse current surge lasts each time the buck switch is turned on. The forward voltage drop is significant in the event the output is short-circuited as it is only this diode's voltage which forces the inductor current to reduce during the forced off-time. For this reason, a higher voltage is better, although that affects efficiency. A good choice is an ultrafast power or Schottky diode with a reverse recovery time of $\approx 30 \text{ ns}$, and a forward voltage drop of $\approx 0.7V$. Other types of diodes may have a lower forward voltage drop, but may have longer recovery times, or greater reverse leakage. $D1$'s reverse voltage rating must be at least as great as the maximum V_{in} , and its current rating be greater than the maximum current limit threshold (370 mA).

C1: This capacitor's purpose is to supply most of the switch current during the on-time, and limit the voltage ripple at V_{IN} , on the assumption that the voltage source feeding V_{IN} has an output impedance greater than zero. At maximum load current, when the buck switch turns on, the current into pin 8 will suddenly increase to the lower peak of the output current waveform, ramp up to the peak value, then drop to zero at turn-off. The average input current during this on-time is the load current (150 mA). For a worst case calculation, $C1$ must supply this average load current during the maximum on-time. To keep the input voltage ripple to less than $2V$ (for this exercise), $C1$ calculates to:

$$C1 = \frac{I \times t_{ON}}{\Delta V} = \frac{0.15A \times 2.47 \mu s}{2.0V} = 0.185 \mu F$$

Quality ceramic capacitors in this value have a low ESR which adds only a few millivolts to the ripple. It is the capacitance which is dominant in this case. To allow for the capacitor's tolerance, temperature effects, and voltage effects, a $1.0 \mu F$, $100V$, $X7R$ capacitor will be used.

C4: The recommended value is $0.022 \mu F$ for $C4$, as this is appropriate in the majority of applications. A high quality ceramic capacitor, with low ESR is recommended as $C4$ supplies the surge current to charge the buck switch gate at turn-on. A low ESR also ensures a quick recharge during each off-time. At minimum V_{IN} , when the on-time is at maximum, it is possible during start-up that $C4$ will not fully recharge during each 300 ns off-time. The circuit will not be able to complete the start-up, and achieve output regulation. This can occur when the frequency is intended to be low (e.g., $R_{ON} = 500K$). In this case $C4$ should be increased so it can maintain suffi-

cient voltage across the buck switch driver during each on-time.

C5: This capacitor helps avoid supply voltage transients and ringing due to long lead inductance at VIN. A low ESR, 0.1 μF ceramic chip capacitor is recommended, located close to the LM5009.

FINAL CIRCUIT

The final circuit is shown in [Figure 5](#). The circuit was tested, and the resulting performance is shown in [Figure 6](#) through [Figure 9](#). For these graphs, the load current was varied from 50mA to 200mA.

MINIMUM LOAD CURRENT

A minimum load current of 1 mA is required to maintain proper operation. If the load current falls below that level, the bootstrap capacitor may discharge during the long off-time, and the circuit will either shutdown, or cycle on and off at a low frequency. If the load current is expected to drop below 1 mA in the application, the feedback resistors should be chosen low enough in value so they provide the minimum required current at nominal Vout.

PC BOARD LAYOUT

The LM5009 regulation and over-voltage comparators are very fast, and as such will respond to short duration noise

pulses. Layout considerations are therefore critical for optimum performance. The components at pins 1, 2, 3, 5, and 6 should be as physically close as possible to the IC, thereby minimizing noise pickup in the PC tracks. The current loop formed by D1, L1, and C2 should be as small as possible. The ground connection from C2 to C1 should be as short and direct as possible.

If the internal dissipation of the LM5009 produces excessive junction temperatures during normal operation, good use of the pc board's ground plane can help considerably to dissipate heat. The exposed pad on the bottom of the LLP-8 package can be soldered to a ground plane on the PC board, and that plane should extend out from beneath the IC to help dissipate the heat. Additionally, the use of wide PC board traces, where possible, can also help conduct heat away from the IC. Judicious positioning of the PC board within the end product, along with use of any available air flow (forced or natural convection) can help reduce the junction temperatures.

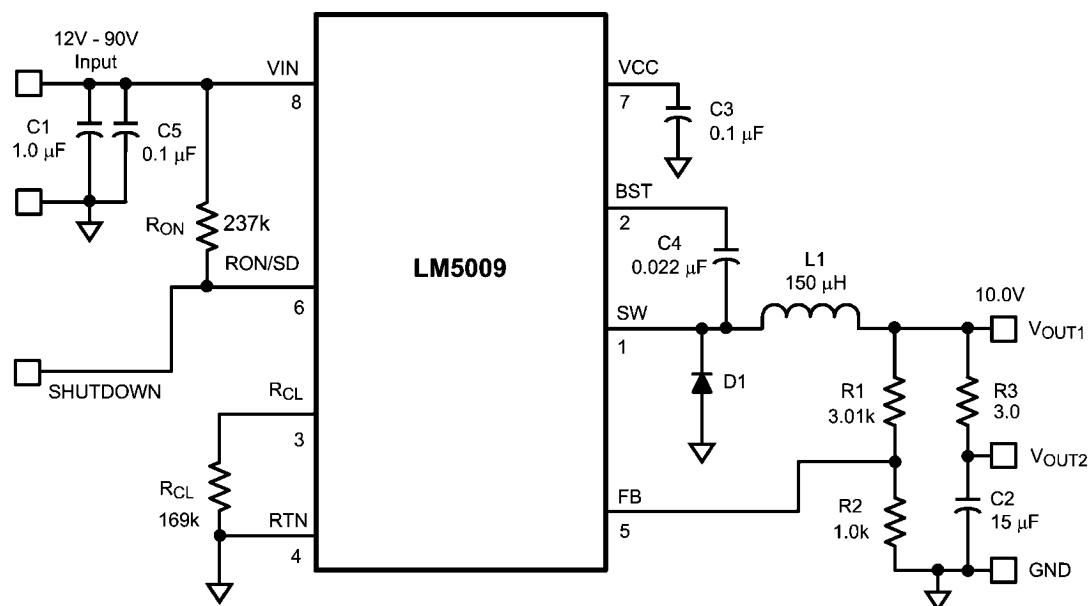

20165822

FIGURE 5. LM5009 Example Circuit

Bill of Materials (Circuit of *Figure 5*)

Item	Description	Part Number	Value
C1	Ceramic Capacitor	TDK C4532X7R2A105M	1 μ F, 100V
C2	Ceramic Capacitor	TDK C4532X7R1E156M	15 μ F, 25V
C3	Ceramic Capacitor	Kemet C1206C104K5RAC	0.1 μ F, 50V
C4	Ceramic Capacitor	Kemet C1206C223K5RAC	0.022 μ F, 50V
C5	Ceramic Capacitor	TDK C3216X7R2A104M	0.1 μ F, 100V
D1	UltraFast Power Diode	Diodes Inc. DFSL1100	100V, 1A
L1	Power Inductor	TDK SLF7045T-151MR33	150 μ H
R1	Resistor	Vishay CRCW12063011F	3.01 k Ω
R2	Resistor	Vishay CRCW12061001F	1.0 k Ω
R3	Resistor	Vishay CRCW12063R00F	3.0 Ω
R _{ON}	Resistor	Vishay CRCW12062373F	237 k Ω
R _{CL}	Resistor	Vishay CRCW12061693F	169 k Ω
U1	Switching Regulator	National Semiconductor LM5009	

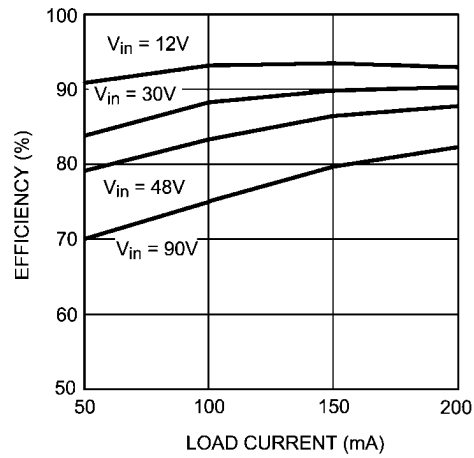

20165823

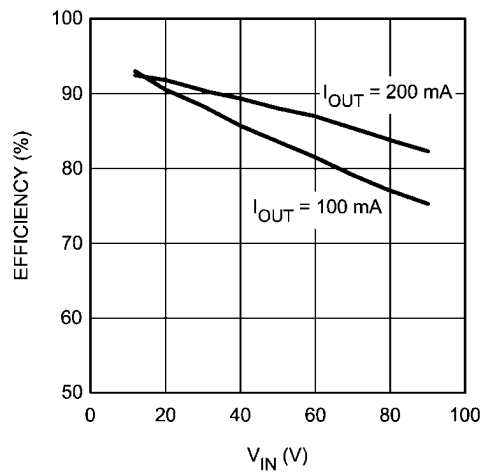
FIGURE 6. Efficiency vs Load Current and V_{IN} 

20165827

FIGURE 7. Efficiency vs V_{IN} and Load Current

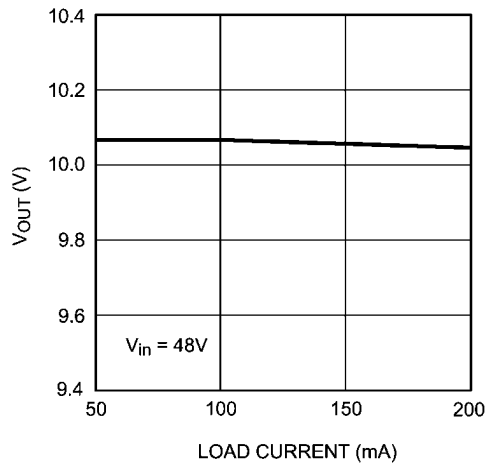

20165824

FIGURE 8. V_{OUT} vs Load Current

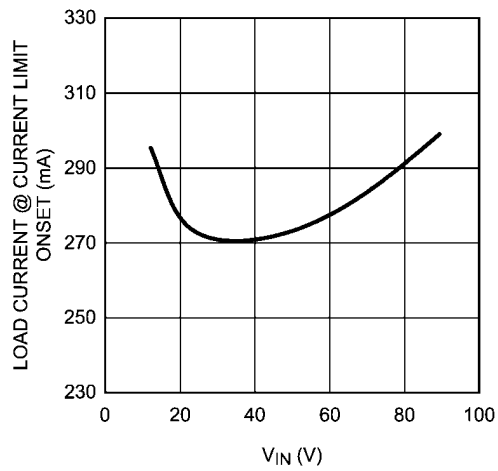

20165831

FIGURE 9. Current Limit vs V_{IN}

Physical Dimensions inches (millimeters) unless otherwise noted

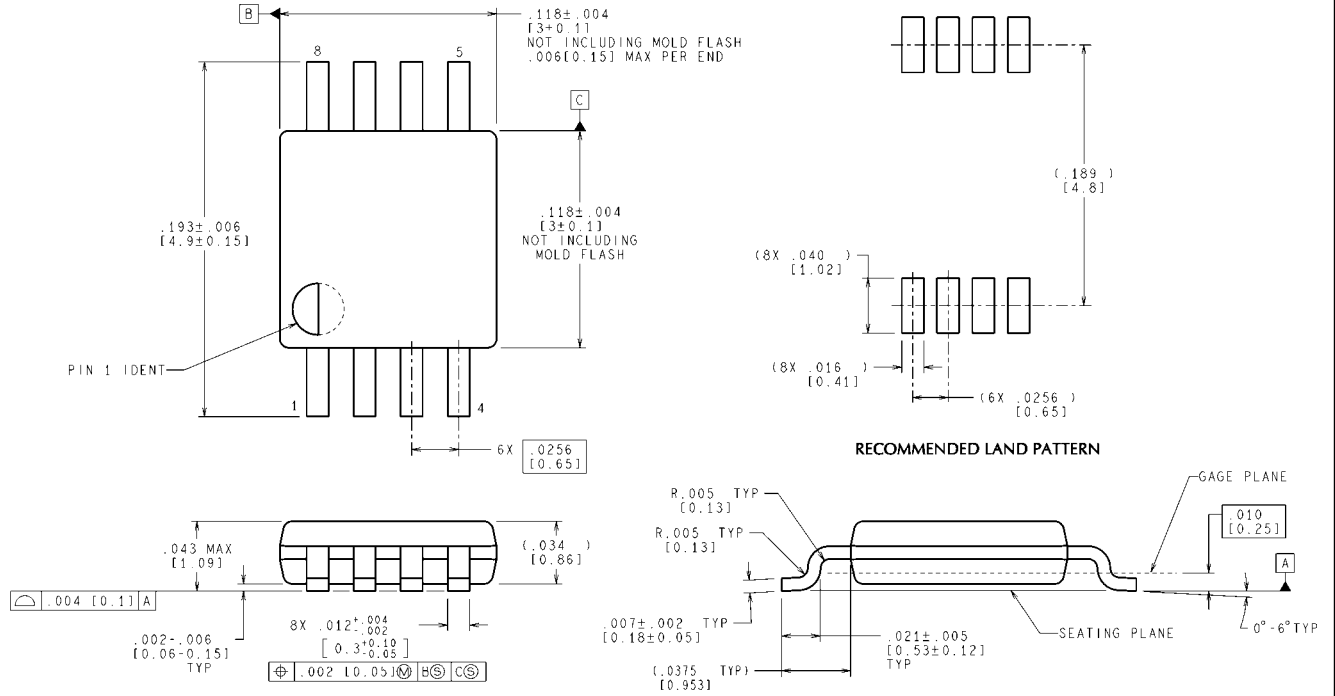

CONTROLLING DIMENSION IS INCH
VALUES IN [] ARE MILLIMETERS

8-Lead MSOP Package
NS Package Number MUA08A

MUA08A (Rev F)

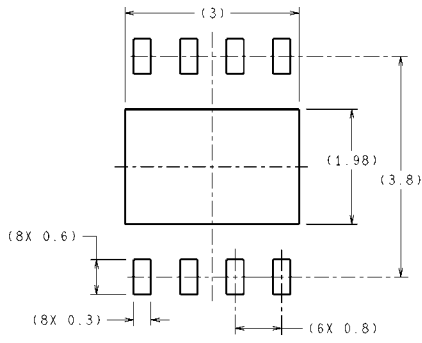

RECOMMENDED LAND PATTERN

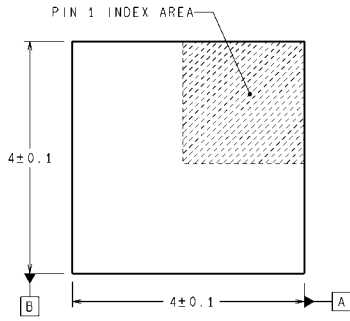

DIMENSIONS ARE IN MILLIMETERS
DIMENSIONS IN () FOR REFERENCE ONLY

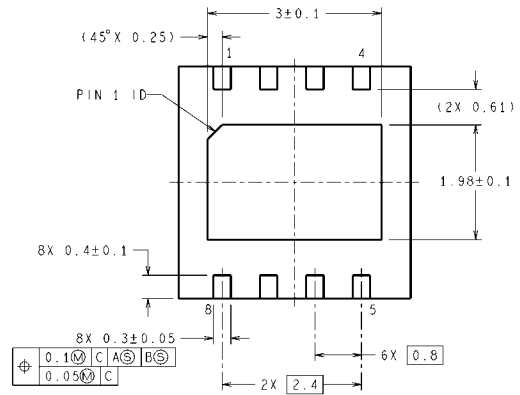
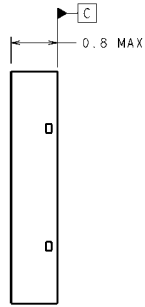
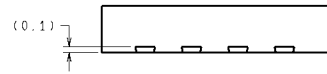

SDC08B (Rev A)

8-Lead LLP Package
NS Package Number SDC08B

Notes

For more National Semiconductor product information and proven design tools, visit the following Web sites at:
www.national.com

Products		Design Support	
Amplifiers	www.national.com/amplifiers	WEBENCH® Tools	www.national.com/webench
Audio	www.national.com/audio	App Notes	www.national.com/appnotes
Clock and Timing	www.national.com/timing	Reference Designs	www.national.com/refdesigns
Data Converters	www.national.com/adc	Samples	www.national.com/samples
Interface	www.national.com/interface	Eval Boards	www.national.com/evalboards
LVDS	www.national.com/lvds	Packaging	www.national.com/packaging
Power Management	www.national.com/power	Green Compliance	www.national.com/quality/green
Switching Regulators	www.national.com/switchers	Distributors	www.national.com/contacts
LDOs	www.national.com/ldo	Quality and Reliability	www.national.com/quality
LED Lighting	www.national.com/led	Feedback/Support	www.national.com/feedback
Voltage References	www.national.com/vref	Design Made Easy	www.national.com/easy
PowerWise® Solutions	www.national.com/powerwise	Applications & Markets	www.national.com/solutions
Serial Digital Interface (SDI)	www.national.com/sdi	Mil/Aero	www.national.com/milaero
Temperature Sensors	www.national.com/tempensors	SolarMagic™	www.national.com/solarmagic
PLL/VCO	www.national.com/wireless	PowerWise® Design University	www.national.com/training

THE CONTENTS OF THIS DOCUMENT ARE PROVIDED IN CONNECTION WITH NATIONAL SEMICONDUCTOR CORPORATION ("NATIONAL") PRODUCTS. NATIONAL MAKES NO REPRESENTATIONS OR WARRANTIES WITH RESPECT TO THE ACCURACY OR COMPLETENESS OF THE CONTENTS OF THIS PUBLICATION AND RESERVES THE RIGHT TO MAKE CHANGES TO SPECIFICATIONS AND PRODUCT DESCRIPTIONS AT ANY TIME WITHOUT NOTICE. NO LICENSE, WHETHER EXPRESS, IMPLIED, ARISING BY ESTOPPEL OR OTHERWISE, TO ANY INTELLECTUAL PROPERTY RIGHTS IS GRANTED BY THIS DOCUMENT.

TESTING AND OTHER QUALITY CONTROLS ARE USED TO THE EXTENT NATIONAL DEEMS NECESSARY TO SUPPORT NATIONAL'S PRODUCT WARRANTY. EXCEPT WHERE MANDATED BY GOVERNMENT REQUIREMENTS, TESTING OF ALL PARAMETERS OF EACH PRODUCT IS NOT NECESSARILY PERFORMED. NATIONAL ASSUMES NO LIABILITY FOR APPLICATIONS ASSISTANCE OR BUYER PRODUCT DESIGN. BUYERS ARE RESPONSIBLE FOR THEIR PRODUCTS AND APPLICATIONS USING NATIONAL COMPONENTS. PRIOR TO USING OR DISTRIBUTING ANY PRODUCTS THAT INCLUDE NATIONAL COMPONENTS, BUYERS SHOULD PROVIDE ADEQUATE DESIGN, TESTING AND OPERATING SAFEGUARDS.

EXCEPT AS PROVIDED IN NATIONAL'S TERMS AND CONDITIONS OF SALE FOR SUCH PRODUCTS, NATIONAL ASSUMES NO LIABILITY WHATSOEVER, AND NATIONAL DISCLAIMS ANY EXPRESS OR IMPLIED WARRANTY RELATING TO THE SALE AND/OR USE OF NATIONAL PRODUCTS INCLUDING LIABILITY OR WARRANTIES RELATING TO FITNESS FOR A PARTICULAR PURPOSE, MERCHANTABILITY, OR INFRINGEMENT OF ANY PATENT, COPYRIGHT OR OTHER INTELLECTUAL PROPERTY RIGHT.

LIFE SUPPORT POLICY

NATIONAL'S PRODUCTS ARE NOT AUTHORIZED FOR USE AS CRITICAL COMPONENTS IN LIFE SUPPORT DEVICES OR SYSTEMS WITHOUT THE EXPRESS PRIOR WRITTEN APPROVAL OF THE CHIEF EXECUTIVE OFFICER AND GENERAL COUNSEL OF NATIONAL SEMICONDUCTOR CORPORATION. As used herein:

Life support devices or systems are devices which (a) are intended for surgical implant into the body, or (b) support or sustain life and whose failure to perform when properly used in accordance with instructions for use provided in the labeling can be reasonably expected to result in a significant injury to the user. A critical component is any component in a life support device or system whose failure to perform can be reasonably expected to cause the failure of the life support device or system or to affect its safety or effectiveness.

National Semiconductor and the National Semiconductor logo are registered trademarks of National Semiconductor Corporation. All other brand or product names may be trademarks or registered trademarks of their respective holders.

Copyright© 2011 National Semiconductor Corporation

For the most current product information visit us at www.national.com



**National Semiconductor
Americas Technical
Support Center**
Email: support@nsc.com
Tel: 1-800-272-9959

**National Semiconductor Europe
Technical Support Center**
Email: europe.support@nsc.com

**National Semiconductor Asia
Pacific Technical Support Center**
Email: ap.support@nsc.com

**National Semiconductor Japan
Technical Support Center**
Email: jpn.feedback@nsc.com