

**NOT RECOMMENDED FOR NEW DESIGNS**

May 1997

## Single Chip TV Chroma/Luminance Processor

### Features

- All Chroma Processing and Demodulating Circuitry on a Single Chip in a 28 Lead Plastic Package
- Phase Locked Subcarrier Regeneration Utilizing Sample and Hold Techniques
- Supplementary ACC with Overload Detector to Prevent Over Saturation of the Picture Tube
- Linear DC Controls for Chroma Gain and Tint
- Dynamic "Flesh Correction" - Corrects Purple and Green Flesh Colors without Affecting Primary Colors
- Balanced Chroma Demodulators with Low Output Impedance for Direct Coupling
- Internal RF Filtering
- Requires Few External Components
- Automatic Beam Limiter
- Chroma Luminance Tracking Picture Control

### Description

The Harris CA3217E (Note) is a monolithic silicon integrated circuit. It contains all the required circuit functions between the video detector and the picture tube RGB driver stages of a color television receiver. The CA3217E decodes the chrominance signals and then produces three different color signals that are internally combined with the luminance to develop the RGB signals. The picture saturation, hue and brightness DC controls are externally adjustable by the viewers. The AFPG, ACC, Dynamic flesh control, Beam limiting and Gate black level (Brightness) control are servo loops used to stabilize the RGB output and reduce frequent manual adjustment. The automatic beam limiter circuit reduces picture contrast and brightness to prevent excessive drive output at the picture tube.

NOTE: Formerly Developmental Type No. TA10806.

### Ordering Information

PART NUMBER	TEMPERATURE RANGE	PACKAGE
CA3217E	-40°C to +85°C	28 Lead PDIP

### Pinout

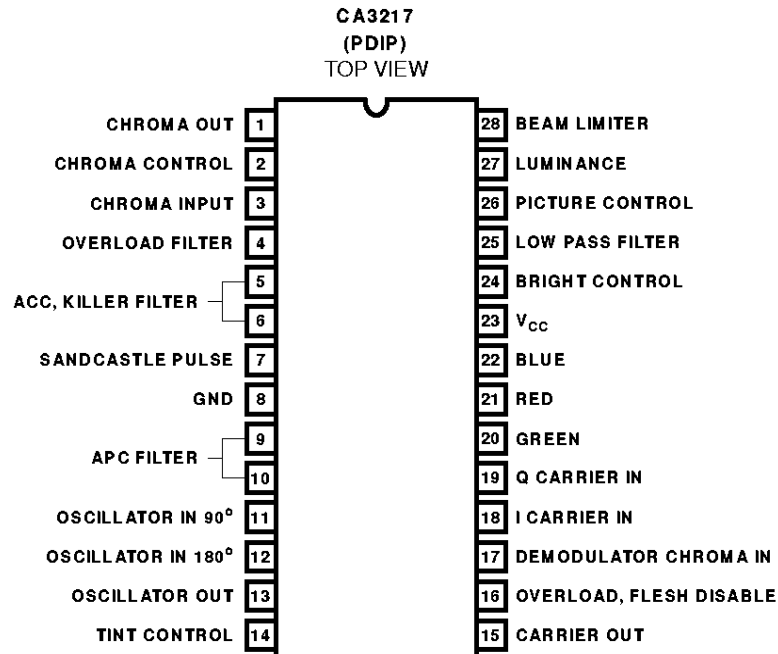

## Specifications CA3217

### Absolute Maximum Ratings

DC Voltage (Between Terminals 23 and 8) ..... 14.0V  
 Power Dissipation  
   Up to  $T_A = +55^\circ\text{C}$  ..... 1.27W  
   Above  $T_A = +55^\circ\text{C}$  ..... Derate Linearly at 13.3mW/ $^\circ\text{C}$   
 Junction Temperature (Plastic Package) ..... +150 $^\circ\text{C}$   
 Storage Temperature Range ..... -65 $^\circ\text{C}$  to +150 $^\circ\text{C}$   
 Lead Temperature (Soldering 10s) ..... +300 $^\circ\text{C}$

### Operating Conditions

Operating Temperature Range ..... -40 $^\circ\text{C}$  to +85 $^\circ\text{C}$

*CAUTION: Stresses above those listed in "Absolute Maximum Ratings" may cause permanent damage to the device. This is a stress only rating and operation of the device at these or any other conditions above those indicated in the operational sections of this specification is not implied.*

### Electrical Specifications $T_A = +25^\circ\text{C}$

PARAMETERS	TEST CONDITIONS										MIN	TYP	MAX	UNITS	
	TEST	S2	S3	S4	S5	S6	mV <sub>P-P</sub> CHROMA	mV <sub>P-P</sub> BURST IN	mV <sub>P-P</sub> LUMA	RELAYS ENERGIZED					
DC ELECTRICAL SPECIFICATIONS (Test 1 Through 5)															
Dissipation	Pin 23	6.3V	11.2V	4.0V	6.3V	11.2V						30	48	66	mA
Pin 1 Bal	XPT1	1.2V	11.2V	4.0V	6.3V	11.2V							10.5		V <sub>DC</sub>
Pin 3 Bal	XPT1	1.2V	11.2V	4.0V	6.3V	11.2V							2.2		V <sub>DC</sub>
Pin 17 Bal	XPT9	1.2V	11.2V	4.0V	6.3V	11.2V							3.0		V <sub>DC</sub>
Pin 13 Bal	XPT 13	1.2V	11.2V	4.0V	6.3V	11.2V							7.5		V <sub>DC</sub>
SWITCHING ELECTRICAL SPECIFICATIONS (Tests 6 Through 26)															
Oscillator Pull-In (Note 1)	"D"	6.3V	11.2V	4.0V	6.3V	11.2V	25	25		K4, K7		-350		+350	Hz
Oscillator Level	"D"	6.3V	11.2V	4.0V	6.3V	11.2V	0	0		K7			0.7		V <sub>P-P</sub>
100% ACC (Note 2)	P21	Vary	11.2V	4.0V	6.3V	11.2V	125	125		K4, K7			1.5		V <sub>P-P</sub>
200% ACC (Note 3)	P21	T8	11.2V	4.0V	6.3V	11.2V	250	250		K4, K7			100		%
20% ACC (Note 3)	P21	T8	11.2V	4.0V	6.3V	11.2V	25	25		K4, K7			90		%
Tint Center (Note 4)	S5	Vary	11.2V	4.0V	Vary	11.2V	250	125		K4, K7			6.5		V <sub>DC</sub>
R-Y Maximum	P21	11.2V	11.2V	6.0V	T11	11.2V	250	125		K1, K4, K7			6.0		V <sub>P-P</sub>
Unkill	P21	11.2V	11.2V	4.0V	T11	11.2V	25	12.5		K4, K7			4.5		V <sub>P-P</sub>
Kill	P21	11.2V	11.2V	4.0V	T11	11.2V	25	2.5		K4, K7				150	mV <sub>P-P</sub>
Chroma Reserver	P21	11.2V	11.2V	4.0V	T11	11.2V	12.5	125		K2, K4, K7			2.0		V <sub>P-P</sub>
Maximum Luma (Note 5)	P21	11.2V	11.2V	4.0V	T11	11.2V			125	K1, K3, K7			2.2		V <sub>P-P</sub>
Luma Ratio (Note 6)	P21	11.2V	6.3V	4.0V	T11	11.2V			125	K1, K3, K7			50		%
Linearity (Note 7)	P21	11.2V	Vary	3.0	T11	11.2V			425	K3, K7			4		V <sub>P-P</sub>
T19 = T19/T18	P21	11.2V	T18	3.0	T11	11.2V			212.5	K3, K7			50		%
4.78MHz Response (Note 8)	P21	11.2V	11.2V	4.0V	T11	11.2V			125	K3, K6, K7	-3		3		dB
Contrast Limit 1 (Note 9)	P24	11.2V	11.2V	4.0V	T11	11.2V			250	K3, K5, K7			3.9		V <sub>DC</sub>
Contrast Limit 2 (Note 9)	P26	11.2V	11.2V	4.0V	T11	11.2V			250	K3, K5, K7			8.2		V <sub>DC</sub>
Bright Limit 1 (Note 10)	P24	11.2V	11.2V	4.0V	T11	11.2V			250	K3, K5, K7			3.1		V <sub>DC</sub>
Bright Limit 2 (Note 10)	P26	11.2V	11.2V	4.0V	T11	11.2V			250	K3, K5, K7			5.6		V <sub>DC</sub>
G-Y Ratio (Note 11)	P20	Vary	11.2V	4.0V	T11	11.2V	250	125					0.33		R
B-Y Ratio (Note 11)	P22	T25	11.2V	4.0V	T11	11.2V	250	125					1.20		R

#### NOTES:

- With  $K_7$  energized and frequency counter at D vary  $C_1$  for 3.579175MHz. Then with  $K_4$  energized, check for pull-in. Repeat for frequency tuned to 3.579875MHz. For all other tests tune to 3.579545MHz  $\pm$ 10Hz.
- Vary  $S_2$  for 1.5V<sub>P-P</sub> at Pin 21.
- % of 100% ACC.
- Adjust  $C_1$  for 3.579545MHz  $\pm$ 10Hz. Adjust  $S_2$  for 1.6V<sub>P-P</sub> at Pin 22 and 0 reference, then adjust  $S_5$  for minimum at P21. Read and record  $S_5$  voltage.
- Black to White.
- T17 = T17/T16.
- Adjust  $S_3$  for 4.0V<sub>P-P</sub>.
- AC amplitude = 50mV<sub>P-P</sub> reference 15kHz.
- Adjust beam limiter to 10.7V.
- Adjust beam limiter to 9.8V.
- Adjust  $S_2$  for 1.5V<sub>P-P</sub> at Pin 21, then calculate P20/P21 and P22/P21.

## Specifications CA3217

### Typical Performance of the CA3217E

FUNCTION	TYPICAL DATA	
Nominal Supply	11.2V	
Nominal Dissipation	500mW	
Oscillator Stability		
Supply Variation $10^{-14}V$	5Hz	
Variation With Temperature ( $\Delta T = +50^{\circ}C$ )	25Hz	
AFPC Characteristics		
DC Loop Gain	33Hz/Degree	
Pull In Range	$\pm 500Hz$	
ACC Characteristics		
100% Chroma Input Level	250mV <sub>p,p</sub> on Red Bar	
3dB Point	At 20% Nominal Input Level	
Hue Control Range	100°	
Saturation Control Range	40dB (Min)	
<b>DEMODULATOR PARAMETERS</b>	<b>RELATIVE AMPLITUDE</b>	<b>ANGLE</b>
R - Y	1.0	93°
B - Y	1.2	2°
G - Y	0.3	258°
Bandwidth (Chroma)	900kHz	
Flesh Control	Primary Control in the +1 Half Plane	
Chroma Overload Control	Two Levels	
Picture Control	40dB	
Brightness Control	Black Level Clamped on 3V to 5V Level	
Beam Limiting	On Picture and Brightness Controls	
Luma Bandwidth	5MHz (Min)	
Sandcastle Input		
1.2 - 2.3V	Blanking	
>3.3V	Burst Gate	
Maximum Linear Output		
R	5V	
G	3V	
B	3.7V	

CA3217

Functional Block Diagram

CA3217E

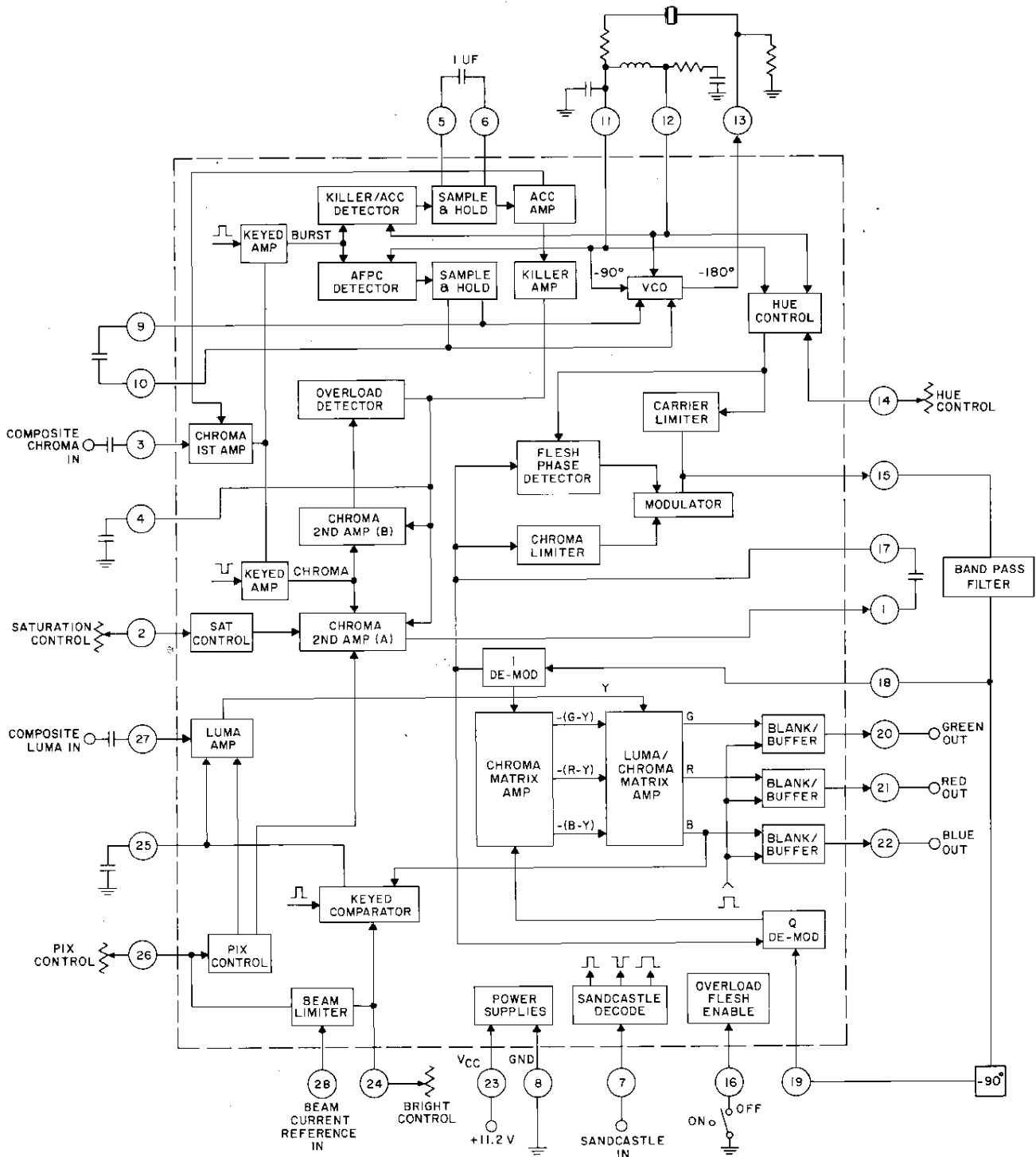

# CA3217

## Schematic Diagram

CA3217E

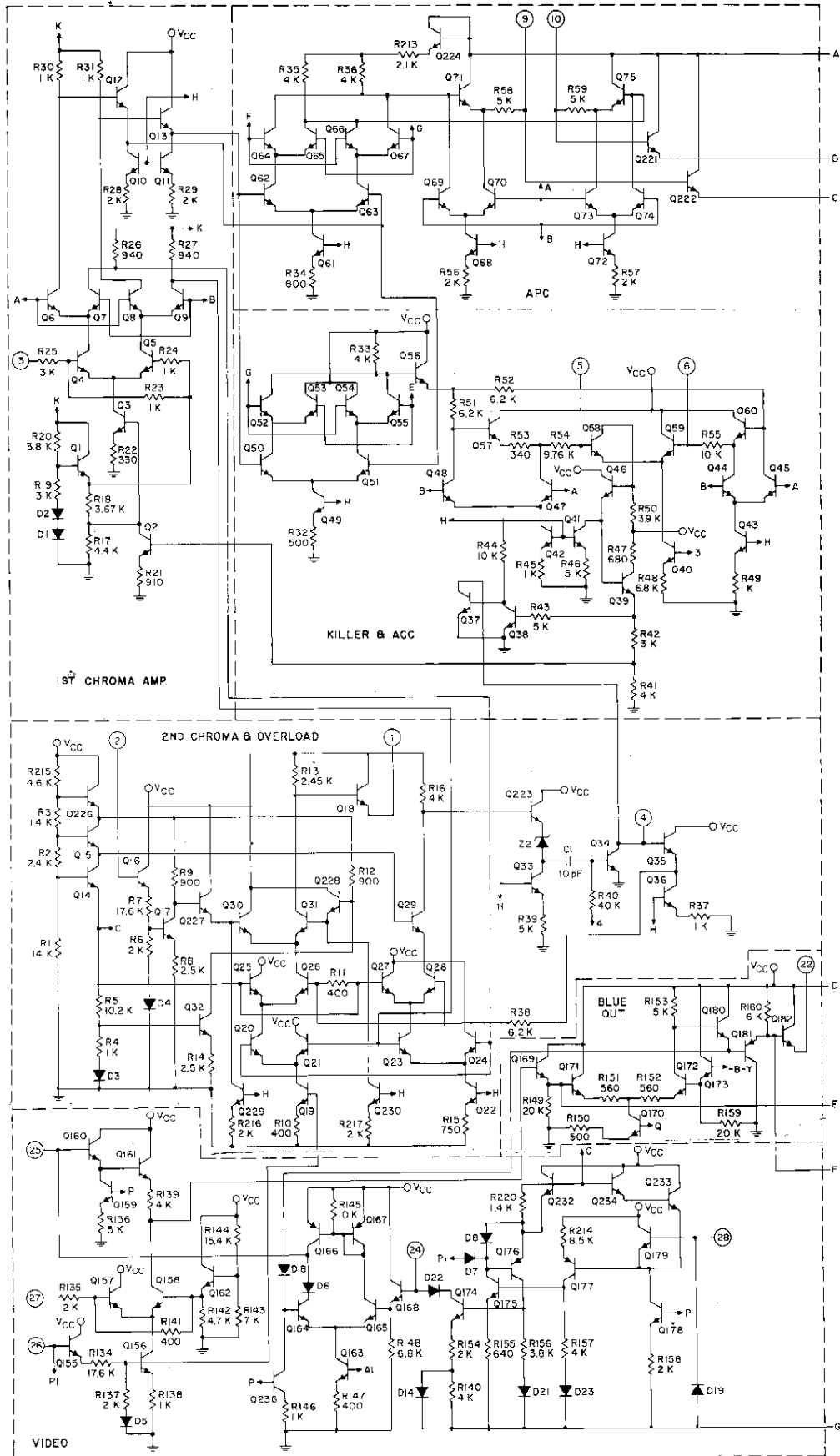



# CA3217

## Test Circuit

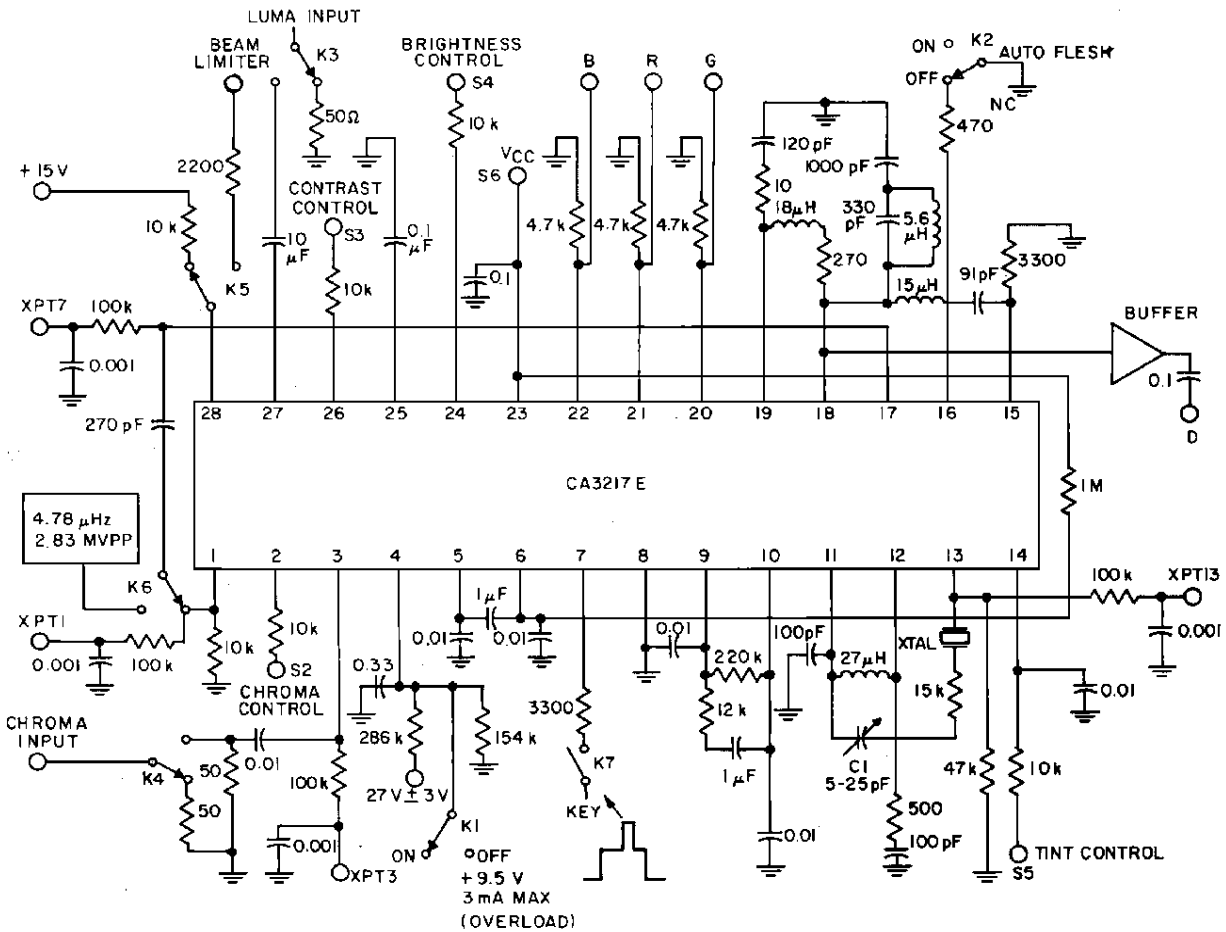

FIGURE 1. TEST CIRCUIT FOR CA3217E

## Typical Performance Curves

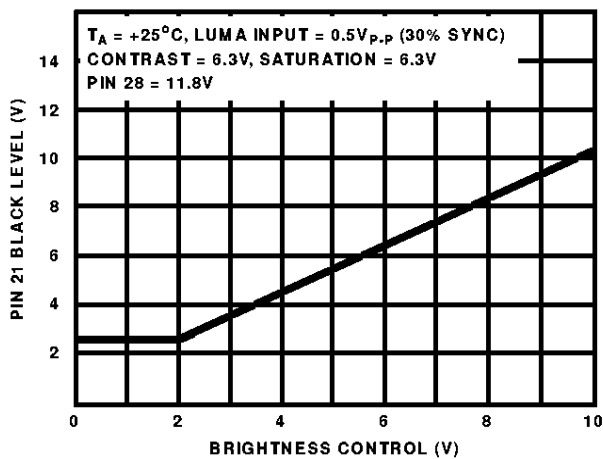

FIGURE 2. TYPICAL P<sub>21</sub> BLACK LEVEL VERSUS BRIGHTNESS CONTROL

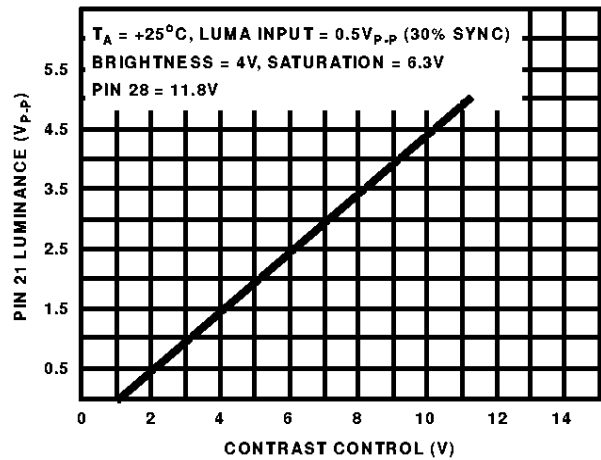

FIGURE 3. TYPICAL P<sub>21</sub> LUMINANCE OUTPUT vs CONTRAST CONTROL

Typical Performance Curves (Continued)

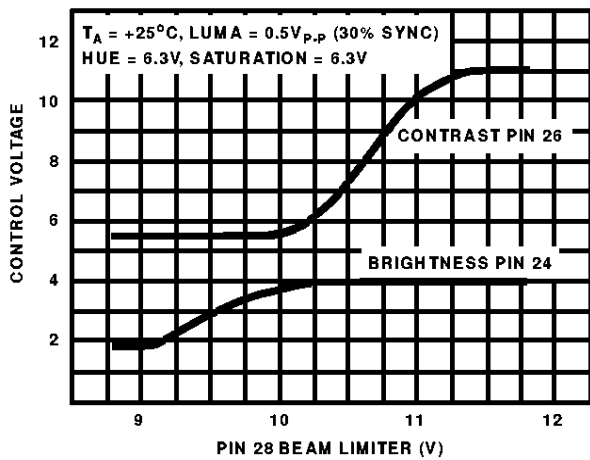

FIGURE 4. TYPICAL BEAM LIMITER vs CONTRAST AND BRIGHTNESS

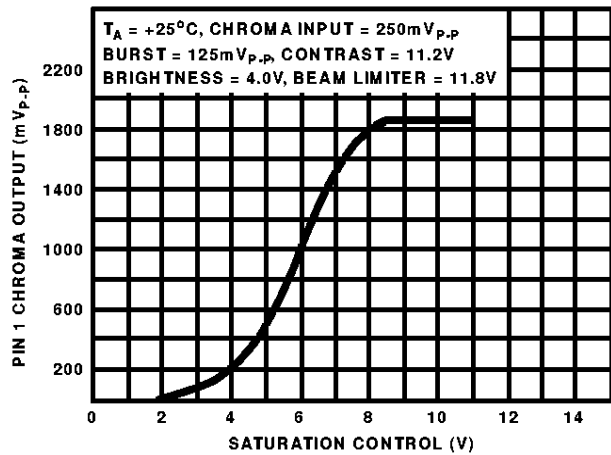

FIGURE 5. TYPICAL P<sub>1</sub> CHROMA OUTPUT vs SATURATION CONTROL

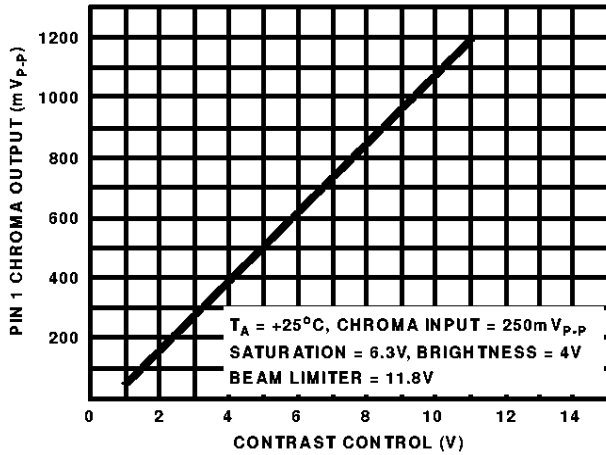

FIGURE 6. TYPICAL P<sub>1</sub> CHROMA OUTPUT vs CONTRAST CONTROL

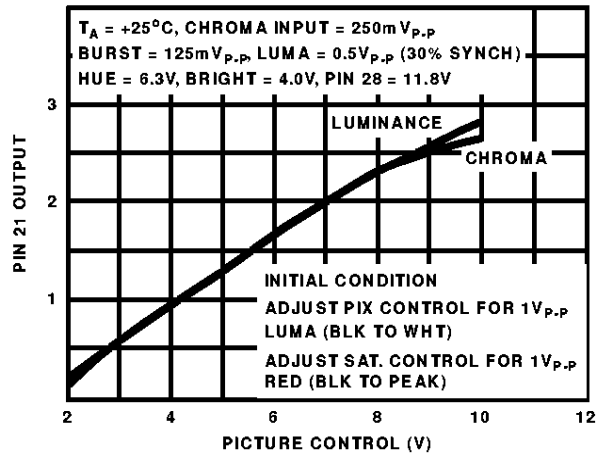

FIGURE 7. TYPICAL LUMA/CHROMA TRACK



# CA3217

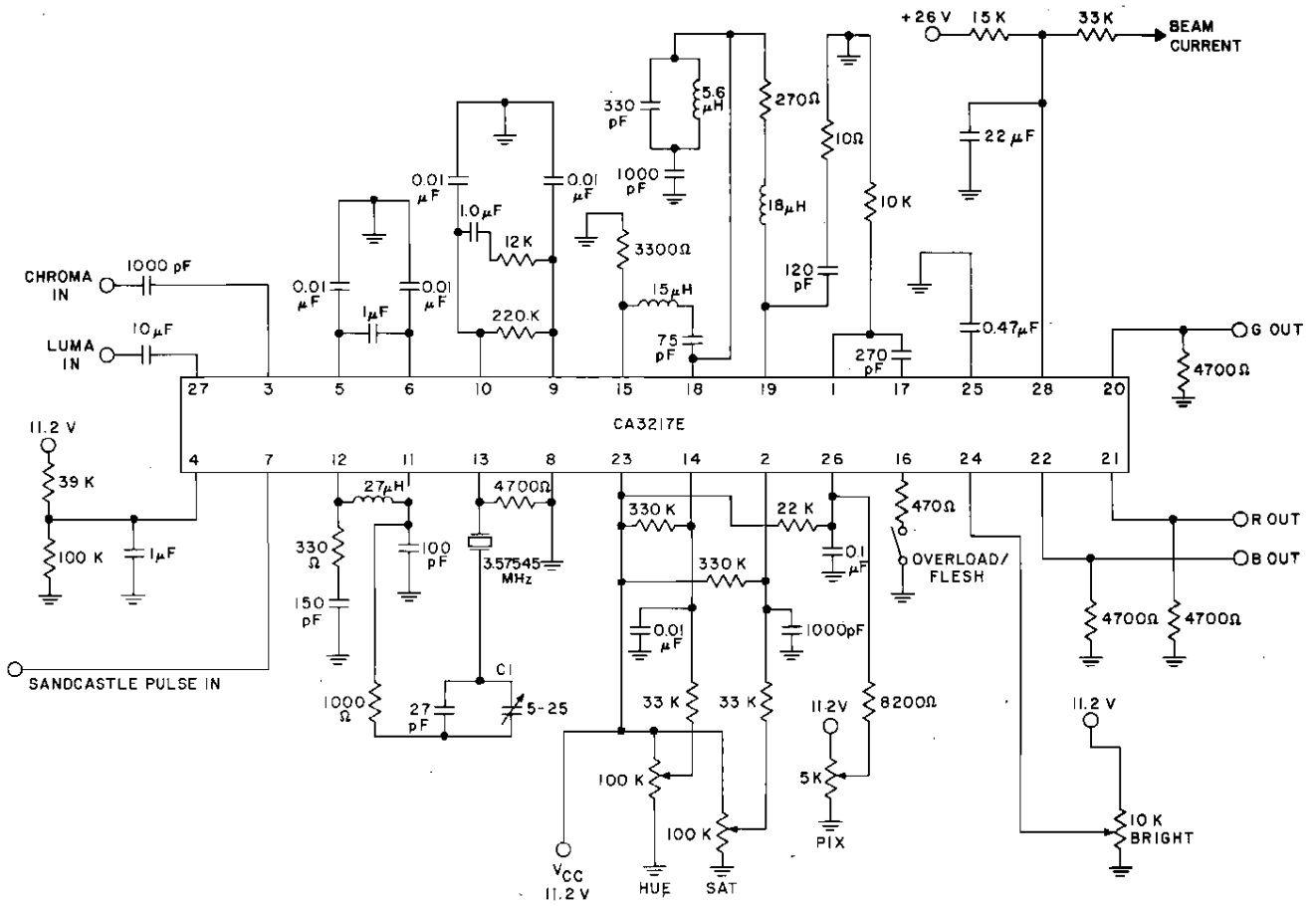

FIGURE 8. TYPICAL APPLICATION CIRCUIT

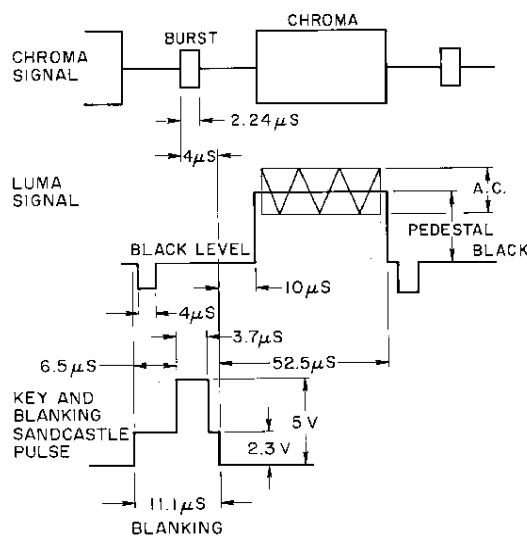

FIGURE 9. TEST SIGNALS FOR THE CA3217E