

National Semiconductor is now part of
Texas Instruments.

Search <http://www.ti.com/> for the latest technical
information and details on our current products and services.

DS22EV5110

DVI, HDMI Extended Reach Equalizer with Retimer and Output De-Emphasis

General Description

The DS22EV5110 is a 6.75 Gbps (3 x 2.25 Gbps) extended reach equalizer optimized for DVI™ and HDMI™ cable extension applications with a high performance re-clocking feature. It supports 3 Transition Minimized Differential Signaling (TMDS®) data channels and a single clock channel over DVI™ v1.0, and HDMI™ v1.3a data rates up to 2.25 Gbps for each data channel. The device incorporates a configurable receive equalizer, a clock and data recovery (CDR) circuit and a de-emphasis driver on each data channel over DVI v1.0, and HDMI v1.3a data rates up to 2.25 Gbps for each data channel. The device incorporates a configurable receive equalizer with a clock and data recovery (CDR) circuit on each data channel. The clock channel feeds a high-performance phase locked loop (PLL) that regenerates a low jitter output clock for data recovery, enabling the extended reach of driving capability feature for repeater application.

The DS22EV5110 equalizes greater than 25 meters 28 AWG of HDMI cable, enabling 1080p resolution with 12 bit deep color depth (2.25 Gbps), to a low jitter version of the clock and data signal outputs, reducing both deterministic and random jitter. Obtaining total jitter is 0.09 UI or less over the supported data rates. This extremely low level of output jitter provides system designers with extra margin and flexibility when working with stringent timing budgets. It is ideal for the DVI and HDMI source and repeater applications.

The transmitter supports configurable transmit de-emphasis so the output can be optimized for driving additional lengths of cables or FR4 traces.

Features

- Optimized for HDMI/DVI source and repeater applications
- TMDS compatible inputs with configurable receive equalization supporting data rates up to 2.25 Gbps
- TMDS compatible outputs with configurable transmit de-emphasis
- Dedicated CDR on each data channel reduces jitter transfer
- Resistor adjustable differential output voltage for AC coupled Cat5e and Cat6 extension applications
- 2 equalizer settings for a wide range of cable reaches up to 2.25 Gbps
- Total Output Jitter of 0.09 UI at 2.25 Gbps
- DVI 1.0 and HDMI v1.3a compatible TMDS source and sink interface
- 7 mm x 7 mm 48 pin LLP package
- >8 kV HBM ESD protection
- 0 °C to +70 °C operating temperature

Applications

- Repeater Applications
 - HDMI / DVI Extender
- Source Applications
 - Video Cards
 - Blu-ray DVD Players
 - Game Consoles
- Sink Applications
 - High Definition Displays
 - Projectors

Application Diagram

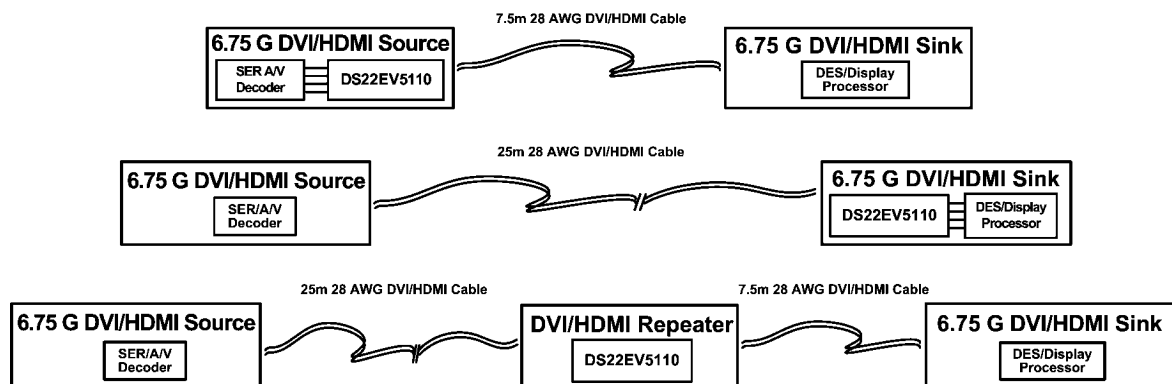

30094953

Pin Descriptions

Pin Name	Pin Number	I/O, Type	Description
High Speed Differential I/O			
C_IN-	1	I, CML	Inverting and non-inverting TMDS Clock inputs to the equalizer. An on-chip 50 Ω terminating resistor connects C_IN+ to V _{DD} and C_IN- to V _{DD} .
C_IN+	2		
D_IN0-	4	I, CML	Inverting and non-inverting TMDS Data inputs to the equalizer. An on-chip 50 Ω terminating resistor connects D_IN0+ to V _{DD} and D_IN0- to V _{DD} .
D_IN0+	5		
D_IN1-	8	I, CML	Inverting and non-inverting TMDS Data inputs to the equalizer. An on-chip 50 Ω terminating resistor connects D_IN1+ to V _{DD} and D_IN1- to V _{DD} .
D_IN1+	9		
D_IN2-	11	I, CML	Inverting and non-inverting TMDS Data inputs to the equalizer. An on-chip 50 Ω terminating resistor connects D_IN2+ to V _{DD} and D_IN2- to V _{DD} .
D_IN2+	12		
C_OUT-	36	O, CML	Inverting and non-inverting TMDS outputs from the equalizer. Open collector.
C_OUT+	35		
D_OUT0-	33	O, CML	Inverting and non-inverting TMDS outputs from the equalizer. Open collector.
D_OUT0+	32		
D_OUT1-	29	O, CML	Inverting and non-inverting TMDS outputs from the equalizer. Open collector.
D_OUT1+	28		
D_OUT2-	26	O, CML	Inverting and non-inverting TMDS outputs from the equalizer. Open collector.
D_OUT2+	25		
Equalization Control			
EQ2	37	I, LVCMOS	EQ2, EQ1 and EQ0 select the equalizer boost level for EQ channels. Internally pulled LOW as default. See Table 1 .
EQ1	38		
EQ0	39		
De-Emphasis Control			
DE1	42	I,	DE1, DE0 select the DE-emphasis level for output drivers. Internally pulled low as default. Refer to Table 2 .
DE0	43	LVCMOS	
Device Control			
BYPASS	47	I, LVCMOS	Reclocker enable control. Internally pulled low as default. H = Reclock and De-Emphasis function is bypassed. L = Normal operation.
EN	44	I, LVCMOS	Enable Output Drivers. Internally pulled HIGH as default. H = normal operation (enabled). L = standby mode.
SD	45	O, LVCMOS	Signal Detect Output pin. H = signal detected on all channels. L = no signal detected on one or more channels.
LOCK	14	O, LVCMOS	Lock Indicator Output pin. H = PLL is locked. L = PLL is not locked.
VOD_CRL	48	I, Analog	VOD control pin. Refer to Table 3 . See <i>Functional Description</i> . External resistance = 24 k Ω to GND, Output DC Coupled Application. External resistance = 12 k Ω to GND, Output AC Coupled Application.
LFp	40	I,	Loop filter capacitor pins. See <i>Functional Description</i> .
LFn	41	Analog	
Power			
V _{DD}	3, 6, 7, 10, 13, 15, 46	Power	V _{DD} = 3.3 V \pm 5%. V _{DD} pins should be tied to the V _{DD} plane through a low inductance path. A 0.1 μ F bypass capacitor should be connected between each V _{DD} pin to the GND planes. See Power Supply Bypassing for additional details.
GND	22, 24, 27, 30, 31, 34	GND	Ground reference. GND should be tied to a solid ground plane through a low impedance path.
Exposed DAP	DAP	GND	Ground reference. The exposed pad at the center of the package must be connected to the ground plane.

Pin Name	Pin Number	I/O, Type	Description
Other			
Reserv	16, 17, 18, 19, 20,21, 23		Reserved. Do not connect. Leave open.

Note: I = Input, O = Output, IO =Input/Output,

Connection Diagram

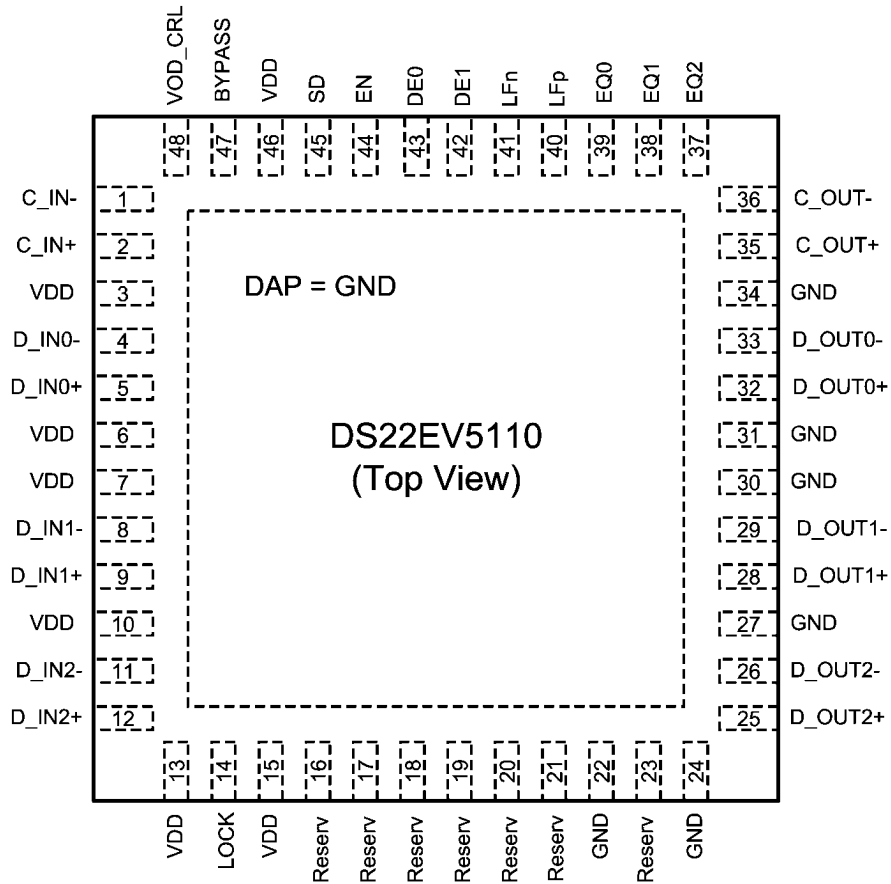

30094952

TOP VIEW — Not to Scale

Ordering Information

NSID	Package	Tape & Reel QTY	Package Number
DS22EV5110SQE	48 Lead LLP	250	SQA48A
DS22EV5110SQ	48 Lead LLP	1000	SQA48A
DS22EV5110SQX	48 Lead LLP	2,500	SQA48A

Absolute Maximum Ratings *(Note 1)*

If Military/Aerospace specified devices are required, please contact the National Semiconductor Sales Office/Distributors for availability and specifications.

Supply Voltage (V_{DD})	-0.5V to 4.0 V
LVC MOS Input Voltage	-0.5V to ($V_{DD} + 0.5$) V
LVC MOS Output Voltage	-0.5V to ($V_{DD} + 0.5$) V
CML Input/Output Voltage	-0.5V to ($V_{DD} + 0.5$) V
Junction Temperature	+125°C
Storage Temperature	-65°C to +150°C
Lead Temp. (Soldering, 5 sec.)	+260°C

ESD Rating

HBM, 1.5 k Ω , 100 pF

>8 kV

Thermal Resistance

 θ_{JA} , No Airflow

33°C/W

Recommended Operating Conditions *(Note 3, Note 4)*

	Min	Typ	Max	Units
Supply Voltage (V_{DD} to GND)	3.135	3.3	3.465	V
Supply Noise Tolerance (100 Hz to 50 MHz)		100		mVp-p
Ambient Temperature	0	25	+70	°C

Electrical Characteristics

Over recommended operating supply and temperature ranges unless otherwise specified. All parameters are guaranteed by test, statistical analysis, or design unless otherwise specified. *(Note 3)*

Symbol	Parameter	Condition	Min	Typ	Max	Unit
Power						
P	Power Supply Consumption	EN = H, Device Enabled PRBS15 pattern, fCLK=225 MHz RT= 50 Ω to AV _{CC} , <i>Figure 2</i>		1000	1150	mW
		EN = L, Standby Mode PRBS15 pattern, fCLK=225 MHz RT= 50 Ω to AV _{CC} , <i>Figure 2</i>		750	900	mW
LVC MOS / LVTTL DC Specifications						
VIH	High level input voltage		2		V_{DD}	V
VIL	Low level input voltage		GND		0.8	V
VOH	High level output voltage	IOH = -3 mA	2.4			V
VOL	Low level output voltage	IOL = 3 mA			0.4	V
IIH	Input High Current	VIN = V_{DD} , EQ2, EQ1, EQ0, DE1, DE0, BYPASS pins (pull down)			60	μ A
		VIN = V_{DD} , EN pin (pull up)	-15			μ A
IIL	Input Low Current	VIN = 0 V, EQ2, EQ1, EQ0, DE1, DE0, BYPASS pins (pull down)			15	μ A
		VIN = 0 V, EN pin (pull up)	-20			μ A
Signal Detect						
SDH	Signal Detect High	Default Input signal level to assert SD pin		80		mVp-p
SDL	Signal Detect Low	Default Input signal level to deassert SD		20		mVp-p

Symbol	Parameter	Condition	Min	Typ	Max	Unit
CML Inputs						
VTX	Input Voltage Swing (Launch Amplitude)	Measured differentially at TPA, Figure 1, note 4	800	1000	1560	mVp-p
VICMDC	Input Common-Mode Voltage	DC-Coupled requirement Measured at TPB, VINmin=800mV, VINmax=1200mV, Figure 1	$V_{DD}-0.3$		$V_{DD}-0.2$	V
VIN	Input Voltage Sensitivity	Measured differentially at TPB, Figure 1 2.25 Gbps, Clock Pattern	150		1560	mVp-p
RIN	Input resistance	IN+ to V_{DD} and IN- to V_{DD}	40	50	60	Ohms
RLI	Differential output return loss	100 MHz — 1125 MHz		10		dB
CML Outputs						
VOFF	Standby Output Voltage	Measured DC outputs at TPC, RT = 50Ω when DUT V_{DD} is off with OUT+ and OUT- terminated by RT= 50Ω to AV_{CC} , Figure 2	$AV_{CC}-10$		$AV_{CC}+10$	mV
VO	Differential Output voltage swing	External resistor = 24 kΩ at VOD_CRL pin. Measured differentially with OUT+ and OUT- terminated by RT=50Ω to AV_{CC} , Figures 2, 3	800		1200	mVp-p
VOCM	Output common-mode Voltage	Measured single-ended, > 1.65 Gbps, Figure 2	$AV_{CC}-0.35$		$AV_{CC}-0.2$	V
tR, tF	Transition time	20% to 80% of differential output voltage, measured within 1" from output pins, Figure 3		85		ps
tCCSK	Inter Pair Data Channel-to-Channel Skew (all 3 data channels)	Difference in 50% crossing between channels 2.25 Gbps, Clock Pattern (Note 4)		2	3	ps
tPPSK	Inter Pair Data Channels Part-toPart Skew	Difference in 50% crossing between channels of any two devices 2.25 Gbps, Clock Pattern		50		ps
tDD	Data Channels Latency	2.25 Gbps, Clock Pattern, Figure 4		400		ps
tCD	Clock Channel Latency	2.25 Gbps, Clock Pattern, Figure 4		600		ps
LVCMOS Outputs						
tSL	SD to LOCK time	Figure 4		4		ms
Bit Rate						
fCLK	Clock Frequency	Clock Path (Note 4)	25		250	MHz
bR	Bit Rate	Data Paths (Note 4)	0.25		2.25	Gbps

Symbol	Parameter	Condition	Min	Typ	Max	Unit
Data Channel Random Jitter						
RJ	Random Jitter	(Note 4 , Note 5 , Note 6)		3		psrms
Data Channel CDR Jitter Generation						
TROJ1	Total Output Jitter 0.25 Gbps	Data Paths, measured at TPC PRBS7, EQ [2:0] = 000 Figure 1 , (Note 4 , Note 5 , Note 6)		0.03	0.05	Ulp-p
TROJ2	Total Output Jitter 1.65 Gbps	Data Paths, measured at TPC PRBS7, EQ [2:0] = 000 Figure 1 , (Note 4 , Note 5 , Note 6)		0.08	0.14	Ulp-p
TROJ3	Total Output Jitter 2.25 Gbps	Data Paths, measured at TPC PRBS7, EQ [2:0] = 000 Figure 1 , (Note 4 , Note 5 , Note 6)		0.09	0.16	Ulp-p
BWLOOP	CDR Loop Bandwidth	0.25 Gbps data rate		0.25		MHz
		1.65 Gbps data rate		1.65		MHz
		2.25 Gbps data rate		2.25		MHz
Clock Channel PLL Jitter Generation						
TROJ4	Total Output Jitter 25 MHz	Clock Path, measured at TPC Figure 1 (Note 4 , Note 5 , Note 6)		0.03	0.045	Ulp-p
TROJ5	Total Output Jitter 165 MHz	Clock Path, measured at TPC Figure 1 (Note 4 , Note 5 , Note 6)		0.07	0.13	Ulp-p
TROJ6	Total Output Jitter 225 MHz	Clock Path, measured at TPC Figure 1 (Note 4 , Note 5 , Note 6)		0.08	0.135	Ulp-p

Note 1: "Absolute Maximum Ratings" are the ratings beyond which the safety of the device cannot be guaranteed. They are not meant to imply that the device should be operated at these limits.

Note 2: Allowed supply noise (mVp-p sine wave) at typical condition.

Note 3: Typical parameters are measured at $V_{DD} = 3.3\text{ V}$, $T_A = 25\text{ }^\circ\text{C}$. They are for reference purposes, and are not production-tested.

Note 4: Parameter is guaranteed by statistical analysis and/or design.

Note 5: Deterministic jitter is measured at the differential outputs (TPC of [Figure 1](#)), minus the deterministic jitter before the test channel (TPA of [Figure 1](#)). Random jitter is removed through the use of averaging or similar means.

Note 6: Total Jitter is defined as peak-to-peak deterministic jitter from + 12 times random jitter (ps).

Note 7: Random jitter contributed by the equalizer is defined as $\text{sq rt}(J_{\text{OUT}}^2 - J_{\text{IN}}^2)$. J_{OUT} is the random jitter at equalizer outputs in ps-rms, see TPC of [Figure 1](#); J_{IN} is the random jitter at the input of the equalizer in ps-rms, see TPA of [Figure 1](#).

Setup and Timing Diagrams

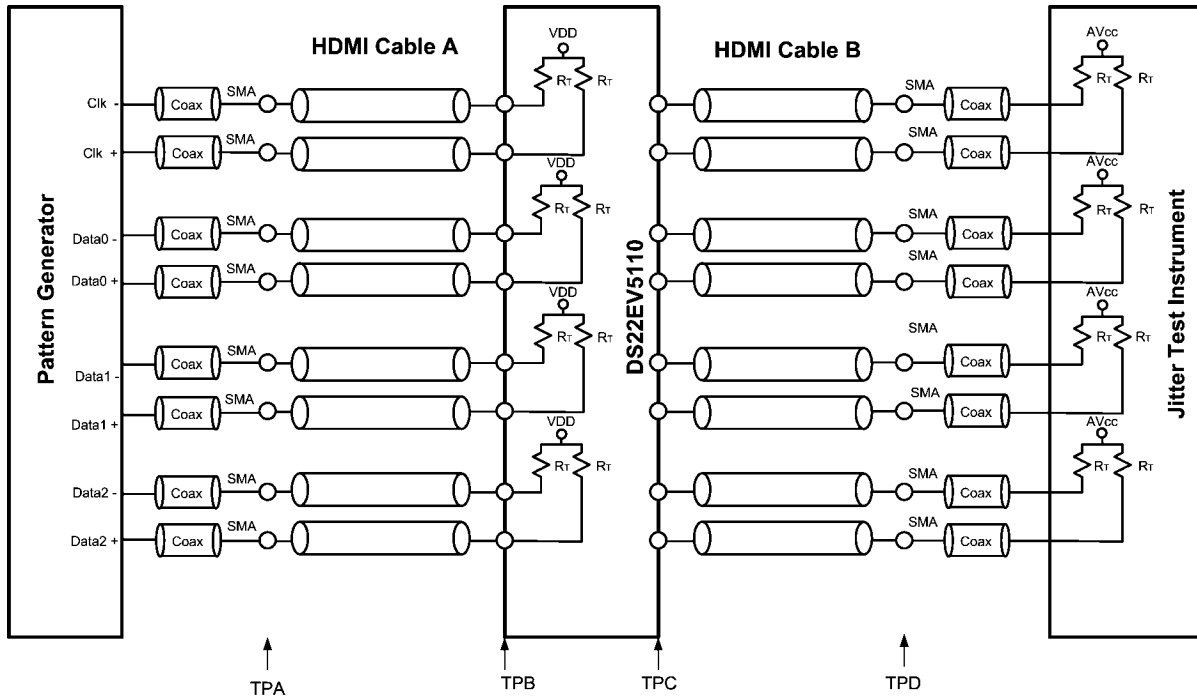

30094910

FIGURE 1. Test Setup Diagram

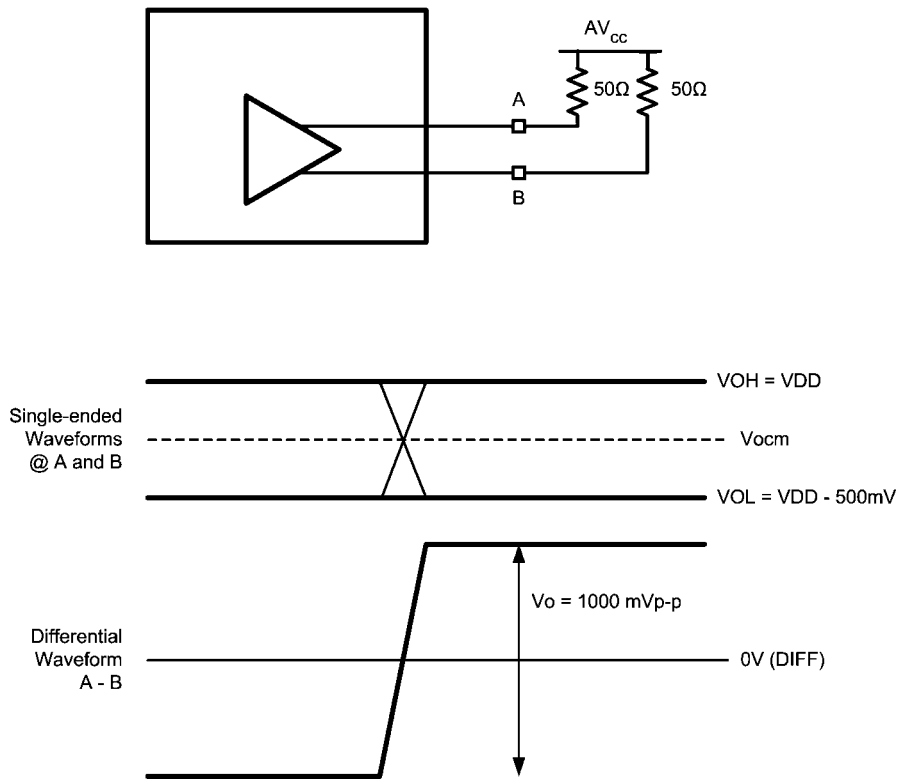

30094912

FIGURE 2. CML Output Swings at A/B (VOD_CRL = 24 kΩ)

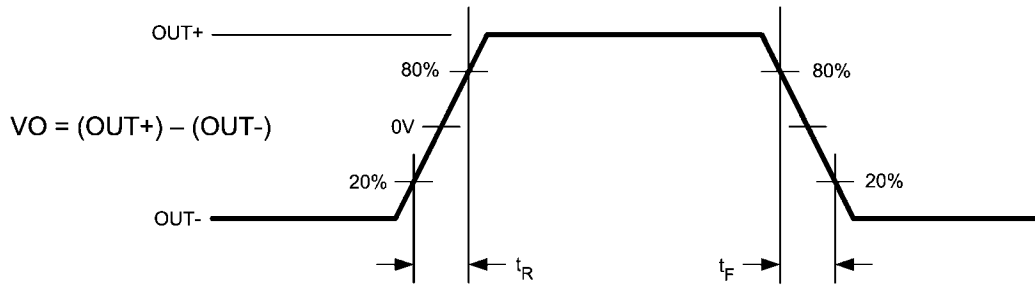

30094911

FIGURE 3. CML Output Transition Times

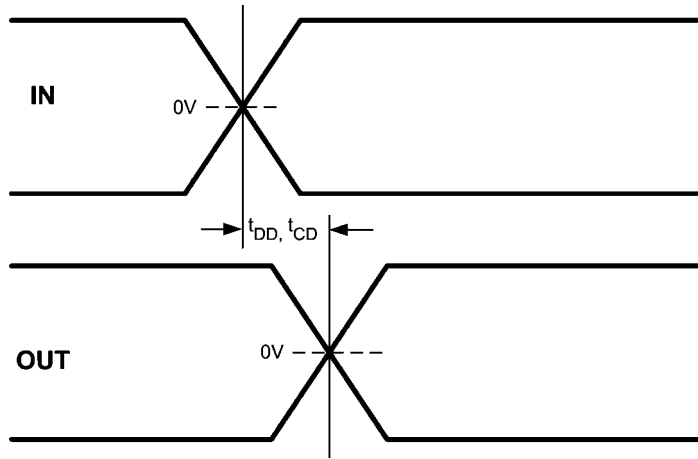

30094913

FIGURE 4. CML Latency Delay Time

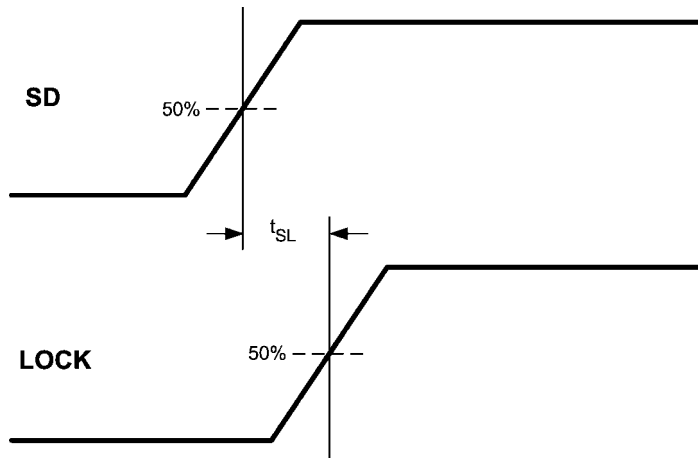

30094914

FIGURE 5. SD - LOCK Delay Time

Functional Description

The DS22EV5110 DVI, HDMI Extended Reach Equalizer with Retimer and Output De-Emphasis consists of three data

channels and a clock channel. Each data channel consists of a TMDS compatible receiver with a power efficient equalizer, a dedicated clock-data recovery (CDR) unit, and a TMDS compatible transmitter.

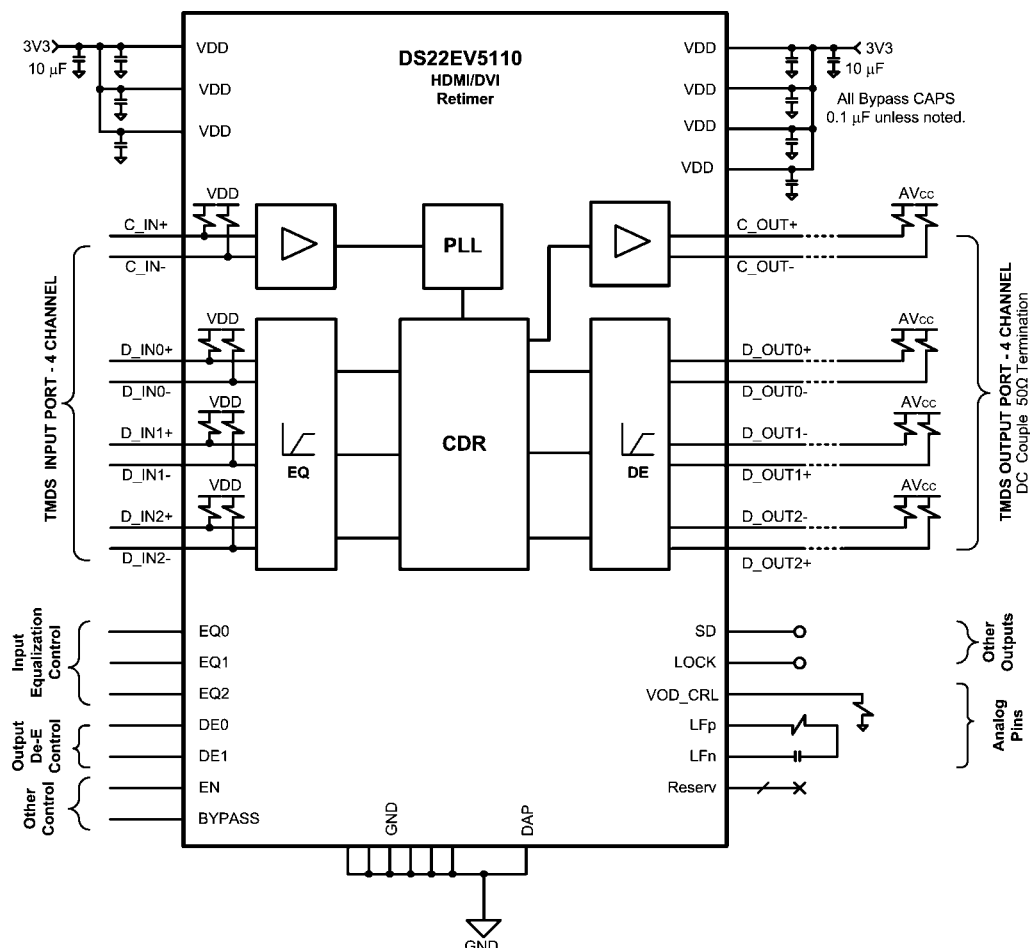

30094915

FIGURE 6. Block Diagram

PHASE-LOCKED-LOCKED LOOP (PLL)

The clock channel has a high-performance PLL that creates a low jitter sampling clock for the clock and data recovery units in the data channels. An external loop filter, composed of 2.2 nF (+ 5% tolerance) capacitor and a 3.3 k Ω (+ 5% tolerance) resistor in series, are required between the LFP and the LFN pins.

CLOCK-DATA RECOVERY UNIT (CDR)

Each TMDS data channel has a CDR that operates independently from other TMDS data channels. Each CDR aligns the sampling clock edges by digitally interpolating the clock from PLL of the TMDS clock channel. The device is designed to connect to DVI/HDMI compatible transmitter and receiver at any data rate between 250 Mbps to 2.25 Gbps. The loop bandwidth of the CDR is approximately $\text{ baud_rate}/1000$, i.e. 2.25 MHz for 2.25 Gbps data.

INPUT EQUALIZATION

The input data channel equalizers support eight programmable levels of equalization boost [Table 1](#) by the EQ

pins (EQ [2:0]). The range of boost settings provided enables the DS22EV5110 to address a wide range of transmission line path loss scenarios, enabling support for a variety of data rates and formats. See *Applications Information* for recommended EQ settings.

OUTPUT DE-EMPHASIS

De-emphasis is the conditioning function for use in compensating against backplane and cable transmission loss. The DS22EV5110 provides four steps of de-emphasis ranging from 0, 3, 6 and 9 dB, user-selectable dependent on the loss profile of output channels. [Table 2](#) shows the De-emphasis control with default $VO = 1000$ mVp-p, and [Figure 7](#) shows a driver de-emphasis waveform.

OUTPUT VO CONTROL

Output differential voltage (VO) is controlled through VOD_CRL pin ties an external resistor to the ground as shown in [Table 3](#). Users should restrict the external resistor values used to be 12 k Ω to 24 k Ω . +5% tolerance is recommended.

TABLE 1. Equalization Control

INPUTS			RESULT
EQ2	EQ1	EQ0	Equalization in dB (1.125 GHz)
0	0	0	0 (default)
0	0	1	12
0	1	0	18
0	1	1	21
1	0	0	24
1	0	1	26
1	1	0	28
1	1	1	30

TABLE 2. De-Emphasis Control

INPUTS		RESULT	
DE1	DE0	VO De-Emphasis level in mVp-p (VODE w/VOD_CRL = 24 kΩ)	VO De-Emphasis in dB
0	0	1000 (default)	0 (default)
0	1	710	-3
1	0	500	-6
1	1	355	-9

TABLE 3. VO Control

External Resistor Value (VOD_CRL pin)	Applications	VO Level (mVp-p)
24 kΩ	DC Coupled	1000
12 kΩ	AC Coupled	1000

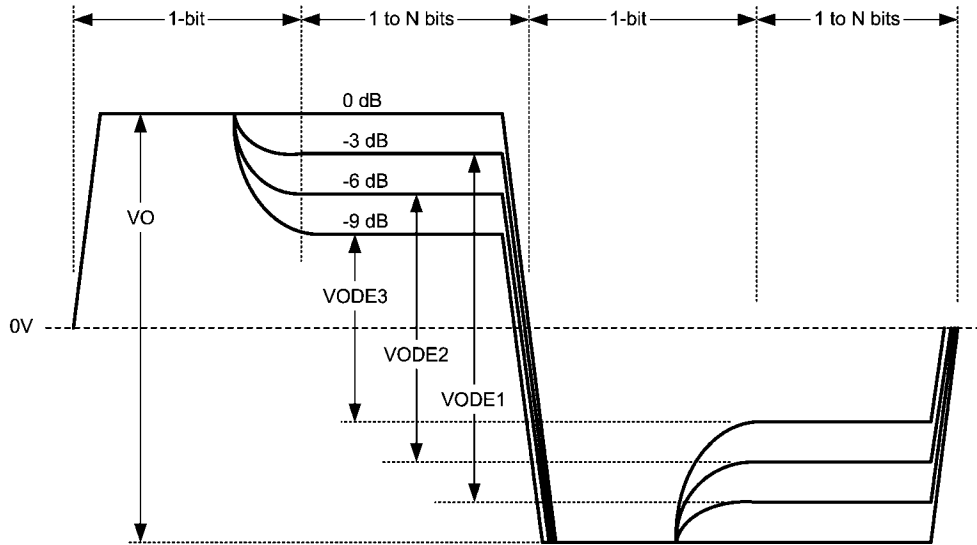

30094916

FIGURE 7. Output De-Emphasis Differential Waveform (showing all de-emphasis steps)

RETIMING AND DE-EMPHASIS BYPASS

The retiming and De-emphasis BYPASS pin provides the flexibility to configure the device to an equalizer only mode. The device is in normal operation, when holding a LOW state on the BYPASS pin. The retiming and De-emphasis features are disabled, when a HIGH state is applied.

DEVICE STATE AND ENABLE CONTROL

The DS22EV5110 has an Enable feature which provides the ability to control device power consumption. This feature can be controlled via the Enable Pin (EN Pin). If Enable is activated, the data channels and clock channel are placed in the ACTIVE state and all device blocks function as described. The DS22EV5110 can also be placed in STANDBY mode to save power. In this mode, the output drivers of the device are disabled. The CML outputs are in the HIGH (AVCC) state. All LVCMOS outputs are in the HiZ state.

LOCK DETECT

When the PLL of the DS22EV5110 is locked, and the generated reference phases are successfully interpolated by the CDR, this status is indicated by a logic HIGH on the LOCK pin. The LOCK pin may be connected to the Enable (EN) pin input to disable the data channels and clock channel when no data signal is being received.

SIGNAL DETECT

The DS22EV5110 features a signal detect circuit on all channels. The status of the input signals can be determined by the state of the SD pin. A logic HIGH indicates the presence of signals that have exceeded a specified maximum threshold value (called SD_ON) on all channels. A logic LOW means that the signals have fallen below a minimum threshold value (called SD_OFF) on one or more channels.

AUTOMATIC ENABLE FEATURE

During normal operation (i.e. BYPASS pin is LOW), the DS22EV5110 can be configured to automatically enter STANDBY mode, if the PLL of the DS22EV5110 is not locked. The STANDBY mode can be implemented by connecting the LOCK DETECT (LOCK) pin to the external (LVCMOS) Enable (EN) pin. If the LOCK pin is connected to the EN pin, a logic HIGH on the LOCK pin will enable the device; thus the DS22EV5110 will automatically enter the ACTIVE state. If the PLL is unlocked, then the LOCK pin will be asserted LOW, causing the aforementioned blocks to be placed in the STANDBY state.

Application Information

The DS22EV5110 is a DVI/HDMI video signal reconditioning device. The device conforms to DVI v1.0 and HDMI v1.3a standards supporting up to 6.75 Gbps total throughput TMDS data for 1080p with 36 bit deep color depth.

TYPICAL APPLICATION

The DS22EV5110 is used as a DVI/HDMI source device, sink device, or a repeater device, see *Figure 8*. As the source de-

vice, the output de-emphasis setting should be configured based on the driving cable length. When used as the sink device, the levels of the equalization boost of the input data channels should be optimized based on the receiving cable length. The DS22EV5110 can also be used as a repeater in an external extender box with the equalization and de-emphasis level settings optimized to provide the maximum cable reach.

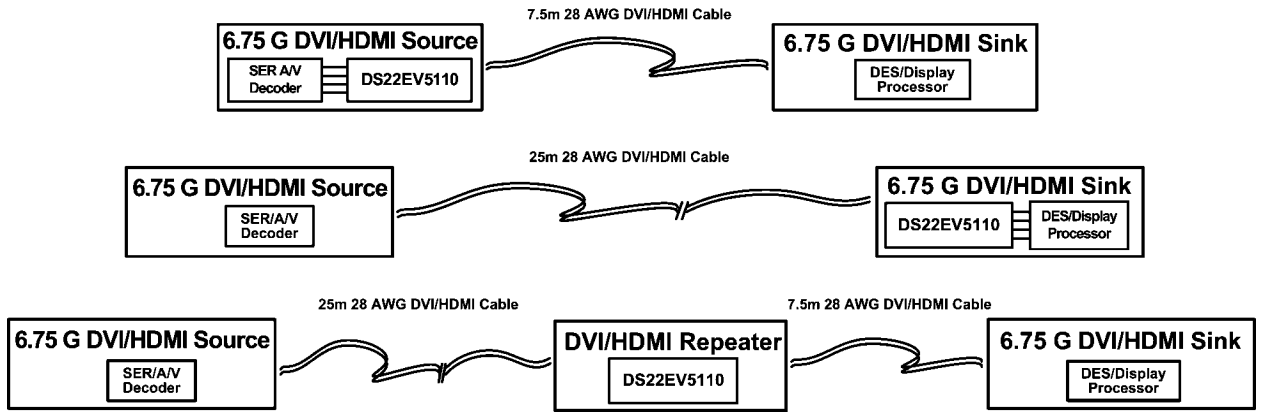

30094953

FIGURE 8. Typical Application Diagram

DC AND AC COUPLED APPLICATIONS

The DS22EV5110 is designed to support TMDS differential pairs with DC coupled transmission lines. It contains integrated termination resistors (50Ω), pulled up to VDD at the input stage, and open collector outputs for DVI / HDMI signaling. Figure 9 shows the DC coupled connection between the HDMI Source (ie. DS22EV5110) and HDMI Sink (ie. DS22EV5110) devices. In the DC coupled application, the external resistance of $24\text{ k}\Omega$ at VOD_CRL pin is used at the Source to ensure the VO level of 1000 mVp-p. The AC coupled method connecting between the Source and the Sink devices may be preferred to eliminate the impact of the

ground potential difference, or to use one CAT5/6 cable between two chassis. To optimize the DS22EV5110 performance, the external resistance of $12\text{ k}\Omega$ at the VOD_CRL pin should be used on the Source DS22EV5110, and a pair of $50\ \Omega$ pull-up resistors should be placed close to the outputs of the Source DS22EV5110, in order to DC bias the output driver. Meanwhile, 622Ω pull-down resistors should be placed at the inputs of the Sink DS22EV5110 device, in order to set the input common mode to a 3.05 V. Note AC coupled configuration is not compliant to the HDMI specification of Source requirement (See Figure 10).

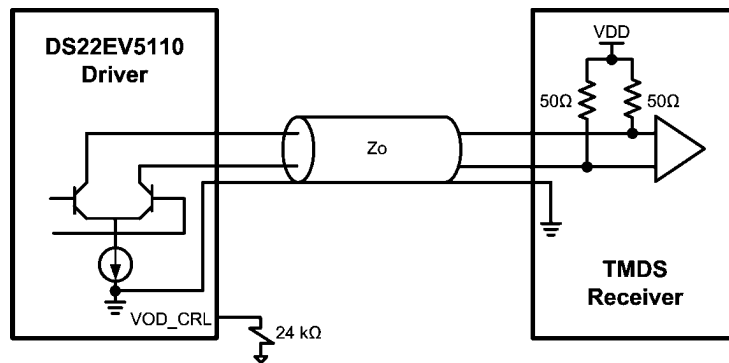

30094920

FIGURE 9. DC Coupled Application

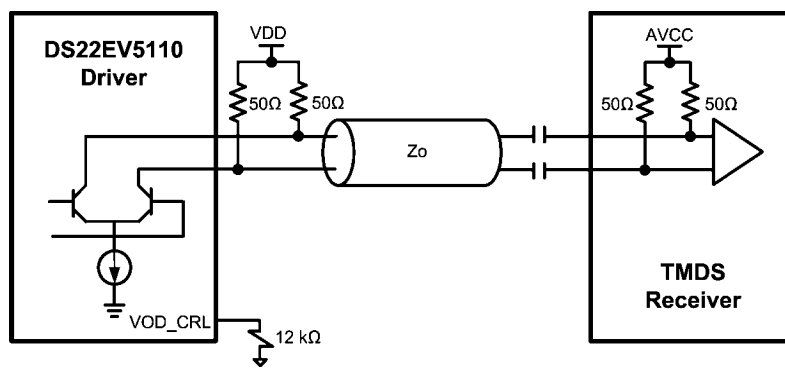

30094921

FIGURE 10. AC Coupled Application

CABLE SELECTION AND INTER-PAIR SKEW

DVI v1.0 and HDMI v1.3a specify Inter-Pair Skew requirements for the system. The DS22EV5110 intends to extend the longer cable reach with STP (DVI / HDMI) cable, or UTP (Cat5 / Cat5e / Cat6) cable, and it does not have a de-skew function to compensate any cable Inter-Pair Skews. Long cable with Inter-Pair Skew exceeding the DVI / HDMI standard limit tolerance could cause system distortion. Therefore, National suggests the consideration of Inter-Pair Skew budget during the system design, and recommends Low-Skew Video grade cables for cable extending applications.

28 AWG STP (SHIELDED TWIST PAIRS) DVI / HDMI CABLES RECOMMENDED EQ SETTINGS

Table 4 provides the recommended EQ control settings for various data rates and cable lengths for 28 AWG DVI/HDMI compliant configurations. The EQ setting is made via three EQ [2:0] pins.

TABLE 4. EQ Control Setting for STP Cable

Format (Data Rate)	0 ~ 10m	> 10m
1080P 36-bit (2.25 Gbps)	Setting 0x01	Setting 0x06
1080P (1.65 Gbps)	Setting 0x01	Setting 0x06
1080I (750 Mbps)	Setting 0x06	Setting 0x06

24 AWG UTP (LOW SKEW UNSHIELDED TWIST PAIRS) CABLES

The DS22EV5110 can be used to extend the length of low skew grade UTP cables, such as Cat5e and Cat6 to distances greater than 30 meters at 1.65 Gbps with < 0.20 UI of jitter. Note that for non-standard DVI/HDMI cables, the user must ensure the inter pair skew requirements are met. Table 5 shows the recommended EQ control settings for various data rates and cable lengths for UTP configurations.

TABLE 5. EQ Control Setting for UTP Cable

Format (Data Rate)	0 ~ 10m	> 10m
1080P 36-bit (2.25 Gbps)	Setting 0x01	Setting 0x05
1080P (1.65 Gbps)	Setting 0x01	Setting 0x05
1080I (750 Mbps)	Setting 0x05	Setting 0x05

General Recommendations

The DS22EV5110 is a high performance circuit capable of delivering excellent performance. To achieve optimal performance, careful attention must be paid to the details associated with high-speed design as well as providing a clean power supply. Refer to the LVDS Owner's Manual for more detailed information on high-speed design tips as well as many other available resources addressing signal integrity design issues.

PCB LAYOUT CONSIDERATIONS FOR DIFFERENTIAL PAIRS

The TMDS differential inputs and outputs must have a controlled differential impedance of $100\ \Omega$. It is preferable to route TMDS lines exclusively on one layer of the board, particularly for the input traces. The use of vias should be avoided if possible. If vias must be used, they should be used sparingly and must be placed symmetrically for each side of a given differential pair. Route the TMDS signals away from other signals and noise sources on the printed circuit board. All traces of TMDS differential inputs and outputs must be equal in length to minimize intra-pair skew.

LLP FOOTPRINT RECOMMENDATIONS

See National application note: AN-1187, "Leadless Lead-frame Package (LLP)" for additional information on LLP packages footprint and soldering information.

POWER SUPPLY BYPASSING

Two approaches are recommended to ensure the DS22EV5110 is provided with an adequate power supply. First, the supply (VDD) and ground (GND) pins should be connected to power planes routed on adjacent layers of the printed circuit board. The layer thickness of the dielectric should be minimized so the VDD and GND planes create a low inductance supply with distributed capacitance. Second, careful attention to supply bypassing through the proper use of bypass capacitors is required. A $0.1\ \mu\text{F}$ bypass capacitor should be connected to each VDD pin such that the capacitor is placed as close as possible to the DS22EV5110. Smaller body size capacitors can help facilitate proper component placement. Additionally, two capacitors with capacitance in the range of $2.2\ \mu\text{F}$ to $10\ \mu\text{F}$ should be incorporated in the power supply bypassing design as well. These capacitors can be either tantalum or an ultra-low ESR ceramic and should be placed as close as possible to the DS22EV5110.

EQUIVALENT I/O STRUCTURES

Figure 14 shows the DS22EV5110 CML output structure and ESD protection circuitry.

Figure 15 shows the DS22EV5110 CML input structure and ESD protection circuitry.

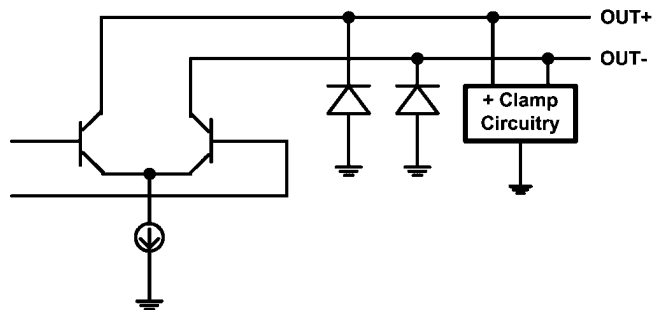

30094922

FIGURE 11. Equivalent Output Structure

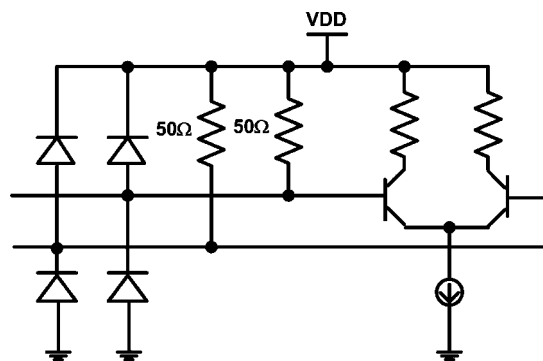

30094923

FIGURE 12. Equivalent Input Structure

Typical Performance Characteristics as a Repeater

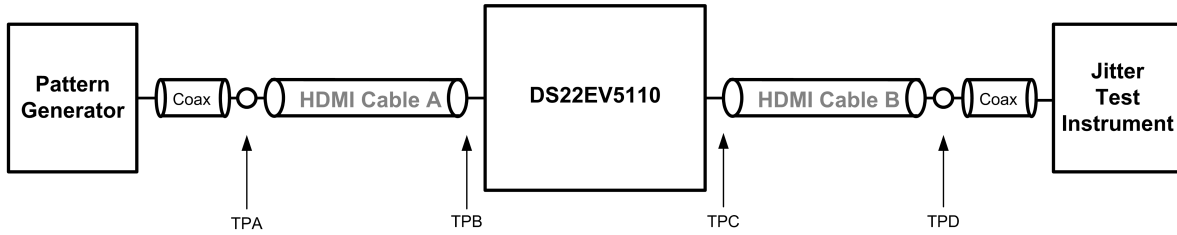

30094909

FIGURE 13. Simplified Test Setup as a Single Repeater

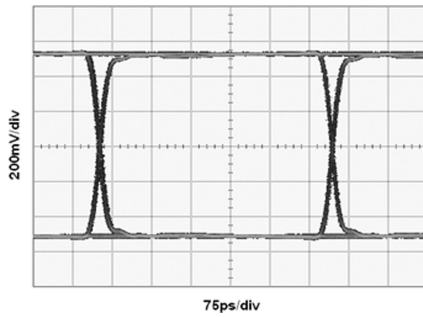

30094960

FIGURE 14. System Source Eye Diagram at TPA (2.25 Gbps)

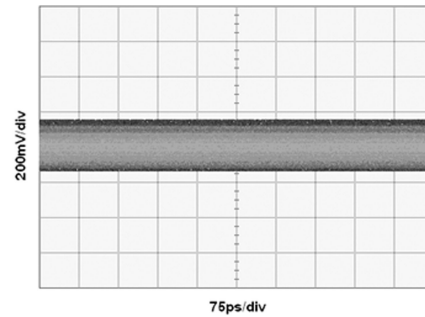

30094961

FIGURE 15. Device Sink Eye Diagram at TPB (2.25 Gbps, Cable A = 25m 28 AWG HDMI)

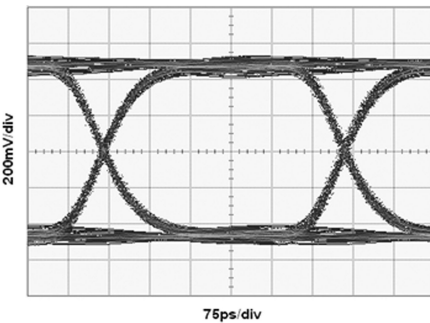

30094962

FIGURE 16. Device Source Eye Diagram at TPC (2.25 Gbps, Cable A = 25m 28 AWG HDMI, EQ = 0x05, BYPASS = 0, DE = 0dB)

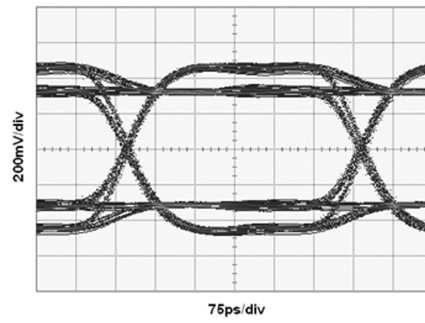

30094963

FIGURE 17. Device Source Eye Diagram at TPC (2.25 Gbps, Cable A = 25m 28 AWG HDMI, EQ = 0x05, BYPASS = 0, DE = -3dB)

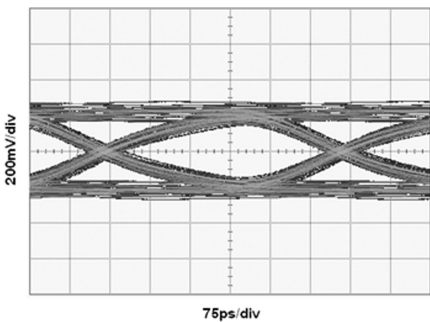

30094964

FIGURE 18. System Sink Eye Diagram at TPD (2.25 Gbps, Cable A = 25m 28 AWG HDMI, Cable B = 7.5m 28AWG HDMI, EQ = 0x05, BYPASS = 0, DE = -3dB)

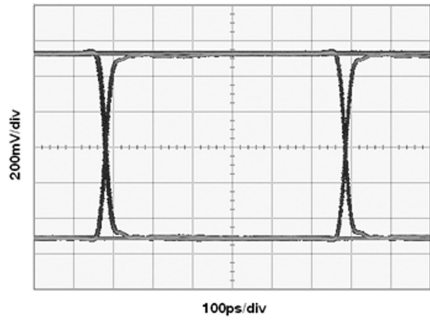

30094965
FIGURE 19. System Source Eye Diagram at TPA (1.65 Gbps)

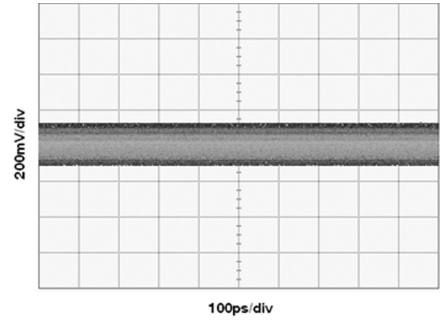

30094966
FIGURE 20. Device Sink Eye Diagram at TPB (1.65 Gbps, Cable A = 35m 28 AWG HDMI)

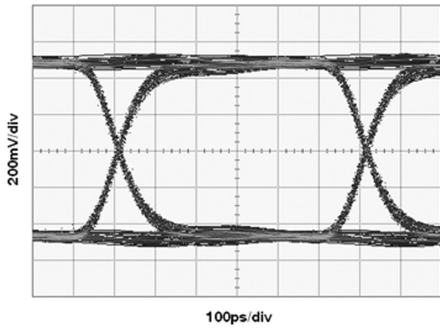

30094967
FIGURE 21. Device Source Eye Diagram at TPC (1.65 Gbps, Cable A = 35m 28 AWG HDMI, EQ = 0x05, BYPASS = 0, DE = 0dB)

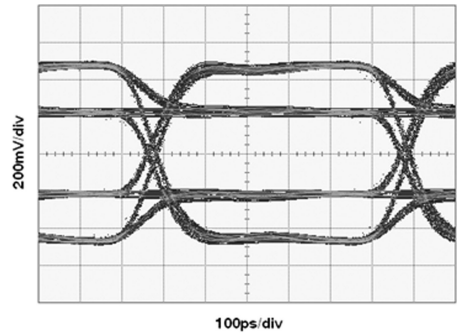

30094968
FIGURE 22. Device Source Eye Diagram at TPC (1.65 Gbps, Cable A = 35m 28 AWG HDMI, EQ = 0x05, BYPASS = 0, DE = -6dB)

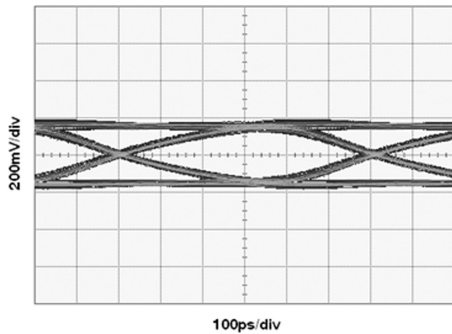

30094969
FIGURE 23. System Sink Eye Diagram at TPD (1.65 Gbps, Cable A = 35m 28 AWG HDMI, Cable B = 10m 28AWG HDMI, EQ = 0x05, BYPASS = 0, DE = -6dB)

Physical Dimensions inches (millimeters) unless otherwise noted

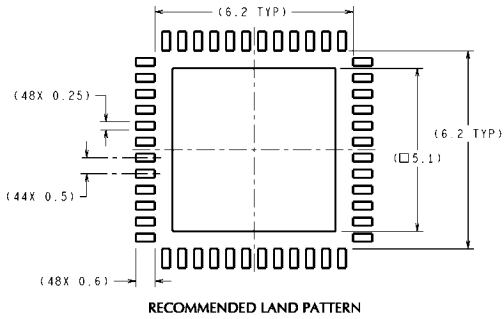

DIMENSIONS ARE IN MILLIMETERS
DIMENSIONS IN () FOR REFERENCE ONLY

RECOMMENDED LAND PATTERN

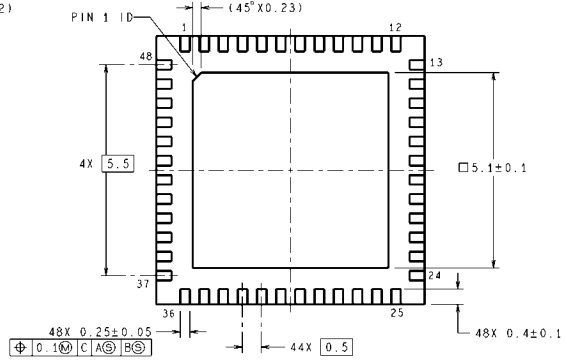
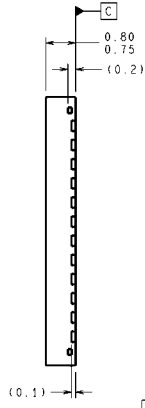
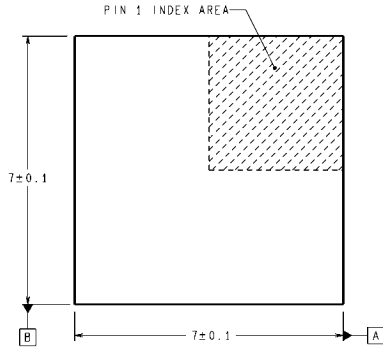

SQA48A (Rev B)

7mm x 7mm 48-pin LLP Package
Order Number DS22EV5110SQ
Package Number SQA48A

Notes

For more National Semiconductor product information and proven design tools, visit the following Web sites at:
www.national.com

Products		Design Support	
Amplifiers	www.national.com/amplifiers	WEBENCH® Tools	www.national.com/webench
Audio	www.national.com/audio	App Notes	www.national.com/appnotes
Clock and Timing	www.national.com/timing	Reference Designs	www.national.com/refdesigns
Data Converters	www.national.com/adc	Samples	www.national.com/samples
Interface	www.national.com/interface	Eval Boards	www.national.com/evalboards
LVDS	www.national.com/lvds	Packaging	www.national.com/packaging
Power Management	www.national.com/power	Green Compliance	www.national.com/quality/green
Switching Regulators	www.national.com/switchers	Distributors	www.national.com/contacts
LDOs	www.national.com/ldo	Quality and Reliability	www.national.com/quality
LED Lighting	www.national.com/led	Feedback/Support	www.national.com/feedback
Voltage References	www.national.com/vref	Design Made Easy	www.national.com/easy
PowerWise® Solutions	www.national.com/powerwise	Applications & Markets	www.national.com/solutions
Serial Digital Interface (SDI)	www.national.com/sdi	Mil/Aero	www.national.com/milaero
Temperature Sensors	www.national.com/tempensors	SolarMagic™	www.national.com/solarmagic
PLL/VCO	www.national.com/wireless	PowerWise® Design University	www.national.com/training

THE CONTENTS OF THIS DOCUMENT ARE PROVIDED IN CONNECTION WITH NATIONAL SEMICONDUCTOR CORPORATION ("NATIONAL") PRODUCTS. NATIONAL MAKES NO REPRESENTATIONS OR WARRANTIES WITH RESPECT TO THE ACCURACY OR COMPLETENESS OF THE CONTENTS OF THIS PUBLICATION AND RESERVES THE RIGHT TO MAKE CHANGES TO SPECIFICATIONS AND PRODUCT DESCRIPTIONS AT ANY TIME WITHOUT NOTICE. NO LICENSE, WHETHER EXPRESS, IMPLIED, ARISING BY ESTOPPEL OR OTHERWISE, TO ANY INTELLECTUAL PROPERTY RIGHTS IS GRANTED BY THIS DOCUMENT.

TESTING AND OTHER QUALITY CONTROLS ARE USED TO THE EXTENT NATIONAL DEEMS NECESSARY TO SUPPORT NATIONAL'S PRODUCT WARRANTY. EXCEPT WHERE MANDATED BY GOVERNMENT REQUIREMENTS, TESTING OF ALL PARAMETERS OF EACH PRODUCT IS NOT NECESSARILY PERFORMED. NATIONAL ASSUMES NO LIABILITY FOR APPLICATIONS ASSISTANCE OR BUYER PRODUCT DESIGN. BUYERS ARE RESPONSIBLE FOR THEIR PRODUCTS AND APPLICATIONS USING NATIONAL COMPONENTS. PRIOR TO USING OR DISTRIBUTING ANY PRODUCTS THAT INCLUDE NATIONAL COMPONENTS, BUYERS SHOULD PROVIDE ADEQUATE DESIGN, TESTING AND OPERATING SAFEGUARDS.

EXCEPT AS PROVIDED IN NATIONAL'S TERMS AND CONDITIONS OF SALE FOR SUCH PRODUCTS, NATIONAL ASSUMES NO LIABILITY WHATSOEVER, AND NATIONAL DISCLAIMS ANY EXPRESS OR IMPLIED WARRANTY RELATING TO THE SALE AND/OR USE OF NATIONAL PRODUCTS INCLUDING LIABILITY OR WARRANTIES RELATING TO FITNESS FOR A PARTICULAR PURPOSE, MERCHANTABILITY, OR INFRINGEMENT OF ANY PATENT, COPYRIGHT OR OTHER INTELLECTUAL PROPERTY RIGHT.

LIFE SUPPORT POLICY

NATIONAL'S PRODUCTS ARE NOT AUTHORIZED FOR USE AS CRITICAL COMPONENTS IN LIFE SUPPORT DEVICES OR SYSTEMS WITHOUT THE EXPRESS PRIOR WRITTEN APPROVAL OF THE CHIEF EXECUTIVE OFFICER AND GENERAL COUNSEL OF NATIONAL SEMICONDUCTOR CORPORATION. As used herein:

Life support devices or systems are devices which (a) are intended for surgical implant into the body, or (b) support or sustain life and whose failure to perform when properly used in accordance with instructions for use provided in the labeling can be reasonably expected to result in a significant injury to the user. A critical component is any component in a life support device or system whose failure to perform can be reasonably expected to cause the failure of the life support device or system or to affect its safety or effectiveness.

National Semiconductor and the National Semiconductor logo are registered trademarks of National Semiconductor Corporation. All other brand or product names may be trademarks or registered trademarks of their respective holders.

Copyright© 2010 National Semiconductor Corporation

For the most current product information visit us at www.national.com



**National Semiconductor
Americas Technical
Support Center**
Email: support@nsc.com
Tel: 1-800-272-9959

**National Semiconductor Europe
Technical Support Center**
Email: europe.support@nsc.com

**National Semiconductor Asia
Pacific Technical Support Center**
Email: ap.support@nsc.com

**National Semiconductor Japan
Technical Support Center**
Email: jpn.feedback@nsc.com