

THIS COPY IS PROVIDED ON A RESTRICTED BASIS AND IS NOT TO BE USED IN ANY WAY DETRIMENTAL TO THE INTERESTS OF PANDUIT CORP.

NOTES:

1. VISIT OUR ON-LINE CATALOG AT WWW.PANDUIT.COM FOR A LIST OF CURRENT PARTS APPLICABLE USE WITH THIS PRODUCT.
2. PRODUCT IS REMOVED THE USB TYPE "C" FEMALE PORT USING THE SMARTKEEPER MASTER KEY (PANDUIT P.N.: SKMKEY).
3. SEE INSTALLATION INSTRUCTION FOR PROPER USE OF PRODUCT.
4. PARTS INCLUDES (DESCRIPTION: MATERIAL/COLOR):
 - 4A. EXTERNAL BODY SHELLS: POLYCARBONATE (PC), FLAME RATING: UL94 V-0/RED.
 - 4B. SMARTKEEPER INTERNAL BODY W/ UNIQUE FEMALE KEYED PATTERN, FLAME RATING: UL94 V-0/RED.
 - 4C. MAIN BODY CLIP: BRASS STEEL/NICKEL.
 - 4D. SMARTKEEPER SIDE SHIELD: BRASS STEEL/NICKEL.
 - 4E. USB TYPE "C" INTERNAL SUPPORT: POLYCARBONATE (PC), FLAME RATING: UL94 V-0/RED.
 - 4F. USB TYPE "C" SIDE EXTERNAL SHIELD: BRASS STEEL/NICKEL.
5. PRODUCT IS DESIGNED FOR INDOOR USE ONLY.
6. OPERATING TEMPERATURE AND HUMIDITY RANGE:
 - 6A. TEMPERATURE RANGE: -4°F (-20°C) TO +140°F (+60°C)
 - 6B. HUMIDITY RANGE: 10-70% NON-CONDENSING RELATIVE HUMIDITY.
7. STORAGE CONDITIONS:
 - 7A. TEMPERATURE RANGE: -4°F (-20°C) TO +176°F (+80°).
 - 7B. HUMIDITY RANGE: 10-80% NON-CONDENSING RELATIVE HUMIDITY.
8. WEIGHT: 0.07 LBS/ (10) PCS [33.5 grams/ (10) PCS].
9. DIMENSIONS IN [] ARE METRIC.
10. ALL MATERIALS AND COMPONENTS USED MEET THE MATERIALS RESTRICTIONS OF RoHs, (EUROPEAN DIRECTIVE 2011/65/EU ON THE RESTRICTION OF HAZARDOUS SUBSTANCES) AS PROPOSED BY THE RoHs TECHNICAL ADAPTATION COMMITTEE.

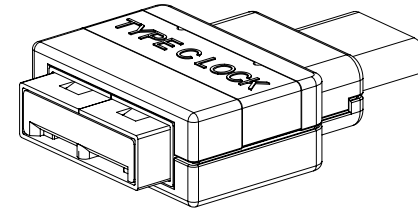
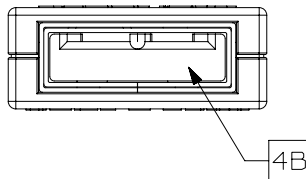
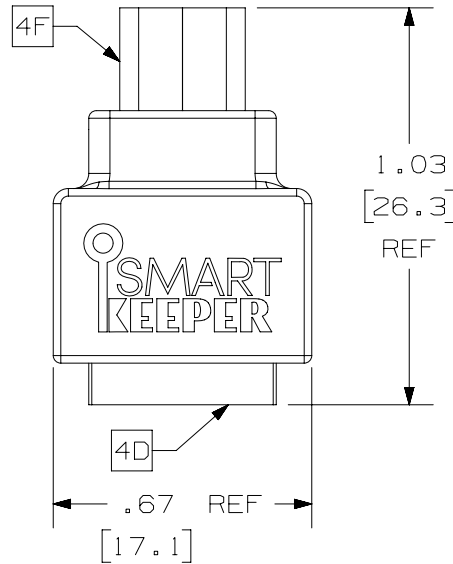
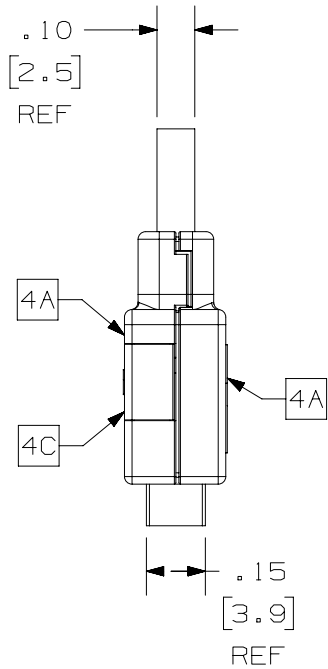
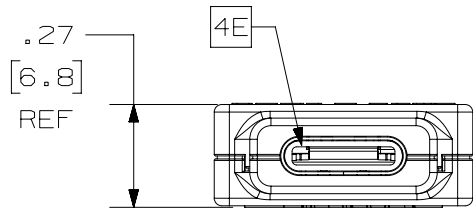

SCALE 2:1

PART NUMBER		SKUSBC		
TITLE				
SMARTKEEPER USB TYPE "C" BLOCKOUT DEVICE				
CUSTOMER DRAWING				
ITEM REVISION NAME		00402NAC/00		
DATASET FILE NAME		00402NAC_DC/00A		
		THIRD ANGLE PROJECTION		
MATERIAL		SEE NOTES		
DRAWING NUMBER		00402NAC-DC		
DRAWN BY	DATE	CHK	SCALE	SIZE
MDJR	04-25-19	DCS	2:1	A
SHEET 1 OF 1				

00A	04-25-19	MDJR	DCS	MMR	DRAWING RELEASED	00402NAB-DC
REV	DATE	BY	CHK	APR	DESCRIPTION	ECN

A-SIZE CUSTOMER

B

B

A

A