



# HD-6402

CMOS Universal Asynchronous Receiver Transmitter (UART)

HD-6402

### Features

- Operation Guaranteed from D.C. to 8.0MHz
- Low Power CMOS Design
- Programmable Word Length, Stop Bits and Parity
- Automatic Data Formatting and Status Generation
- Compatible with Industry Standard UARTs
- Single +5V Power Supply

### Description

The HD-6402 is a CMOS UART for interfacing computers or microprocessors to an asynchronous serial data channel. The receiver converts serial start, data, parity, and stop bits. The transmitter converts parallel data into serial form and automatically adds start, parity, and stop bits. The data word length can be 5, 6, 7 or 8 bits. Parity may be odd or even. Parity checking and generation can be inhibited. The stop bits may be one or two or one and one-half when transmitting 5 bit code.

The HD-6402 can be used in a wide range of applications including modems, printers, peripherals and remote data acquisition systems. Utilizing the HARRIS advanced scaled SAJI IV CMOS process permits operation clock frequencies up to 8.0MHz (500K Baud). Power requirements, by comparison, are reduced from 300mW to 10mW. Status logic increases flexibility and simplifies the user interface.

### Pinout

TOP VIEW

VCC	1	40	TRC
NC	2	39	EPE
GND	3	38	CLS1
RRD	4	37	CLS2
RBR8	5	36	SBS
RBR7	6	35	PI
RBR6	7	34	CRL
RBR5	8	33	TBR8
RBR4	9	32	TBR7
RBR3	10	31	TBR6
RBR2	11	30	TBR5
RBR1	12	29	TBR4
PE	13	28	TBR3
FE	14	27	TBR2
OE	15	26	TBR1
SFD	16	25	TRO
RRC	17	24	TRE
DRR	18	23	TBR1
DR	19	22	TBRE
RRI	20	21	MR

### Functional Diagram

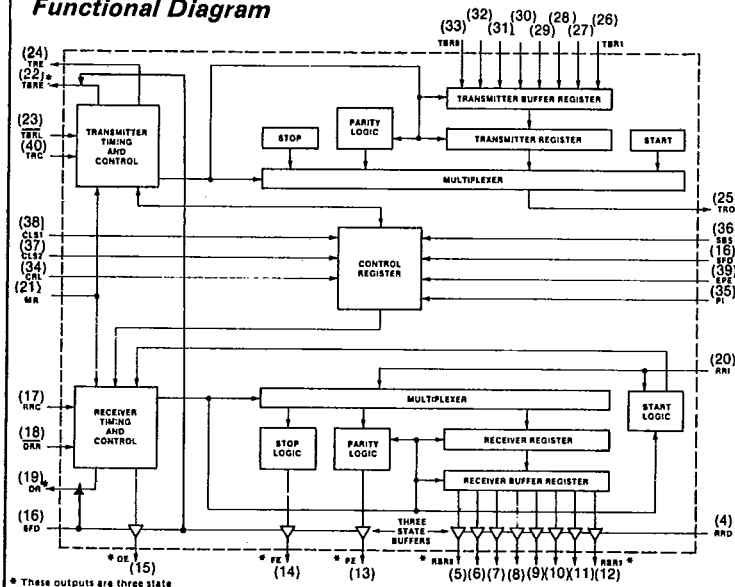

### Control Definition

CONTROL WORD		CHARACTER FORMAT						
C	L	S	P	B	START	DATA	PARITY	STOP
2	1	E	S	BIT	BIT	BIT	BIT	BITS
0	0	0	0	0	1	5	ODD	1
0	0	0	0	1	1	5	ODD	1.5
0	0	0	1	0	1	5	EVEN	1
0	0	0	1	1	1	5	EVEN	1.5
0	0	1	X	0	1	5	NONE	1
0	0	1	X	1	1	5	NONE	1.5
0	1	0	0	0	1	6	ODD	1
0	1	0	0	1	1	6	ODD	2
0	1	0	1	0	1	6	EVEN	1
0	1	0	1	1	1	6	EVEN	2
0	1	1	X	0	1	6	NONE	1
0	1	1	X	1	1	6	NONE	2
1	0	0	0	0	1	7	ODD	1
1	0	0	0	1	1	7	ODD	2
1	0	0	1	0	1	7	EVEN	1
1	0	0	1	1	1	7	EVEN	2
1	0	1	X	0	1	7	NONE	1
1	0	1	X	1	1	7	NONE	2
1	1	0	0	0	1	8	ODD	1
1	1	0	0	1	1	8	ODD	2
1	1	0	1	0	1	8	EVEN	1
1	1	0	1	1	1	8	EVEN	2
1	1	1	X	0	1	8	NONE	1
1	1	1	X	1	1	8	NONE	2

CAUTION: These devices are sensitive to electronic discharge. Proper I.C. handling procedures should be followed.

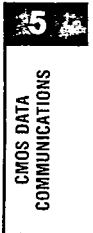

**Pin Description**

PIN	TYPE	SYMBOL	DESCRIPTION
1		V <sub>CC</sub> *	Positive Voltage Supply
2		NC	No connection
3		GND	Ground
4	I	RRD	A high level on RECEIVER REGISTER DISABLE forces the receiver holding outputs RBR1-RBR8 to a high impedance state.
5	O	RBR8	The contents of the RECEIVER BUFFER REGISTER appear on these three-state outputs. Word formats less than 8 characters are right justified to RBR1.
6	O	RBR7	See Pin 5-RBR8
7	O	RBR6	See Pin 5-RBR8
8	O	RBR5	See Pin 5-RBR8
9	O	RBR4	See Pin 5-RBR8
10	O	RBR3	See Pin 5-RBR8
11	O	RBR2	See Pin 5-RBR8
12	O	RBR1	See Pin 5-RBR8
13	O	PE	A high level on PARITY ERROR indicates received parity does not match parity programmed by control bits. When parity is inhibited this output is low.
14	O	FE	A high level on FRAMING ERROR indicates the first stop bit was invalid.
15	O	OE	A high level on OVERRUN ERROR indicates the data received flag was not cleared before the last character was transferred to the receiver buffer register.

PIN	TYPE	SYMBOL	DESCRIPTION
16	I	SFD	A high level on STATUS FLAGS DISABLE forces the outputs PE, FE, OE, DR, TBRE to a high impedance state.
17	I	RRC	The Receiver register clock is 16X the receiver data rate.
18	I	DRR	A low level on DATA RECEIVED RESET clears the data received output DR to a low level.
19	O	DR	A high level on DATA RECEIVED indicates a character has been received and transferred to the receiver buffer register.
20	I	RRI	Serial data on RECEIVER REGISTER INPUT is clocked into the receiver register.
21	I	MR	A high level on MASTER RESET clears PE, FE, OE, and DR to a low level and sets the transmitter register empty (TRE) to a high level 18 clock cycles after MR falling edge. MR does not clear the receiver buffer register. This input must be pulsed at least once after power up. The HD-6402 must be master reset after power up. The reset pulse should meet VIH and tMR. Wait 18 clock cycles after the falling edge of MR before beginning operation.
22	O	TBRE	A high level on TRANSMITTER BUFFER REGISTER EMPTY indicates the transmitter buffer register has transferred its data to the transmitter register and is ready for new data.

\*A 0.1µF decoupling capacitor from the V<sub>CC</sub> pin to the GND pin is recommended.

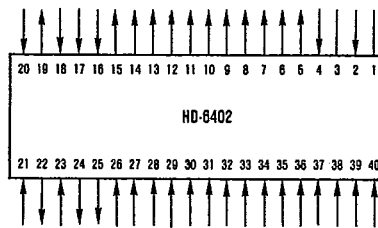

PIN	TYPE	SYMBOL	DESCRIPTION
23	I	TBRL	A low level on TRANSMITTER BUFFER REGISTER LOAD transfers data from inputs TBR1-TBR8 into the transmitter buffer register. A low to high transition on TBRL initiates data transfer to the transmitter register. If busy, transfer is automatically delayed so that the two characters are transmitted end to end.
24	O	TRE	A high level on TRANSMITTER REGISTER EMPTY indicates completed transmission of a character including stop bits.
25	O	TRO	Character data, start data and stop bits appear serially at the TRANSMITTER REGISTER OUTPUT.
26	I	TBR1	Character data is loaded into the TRANSMITTER BUFFER REGISTER via inputs TBR1-TBR8. For character formats less than 8 bits the TBR8, 7, and 6 inputs are ignored corresponding to their programmed word length.
27	I	TBR2	See Pin 26 - TBR1.
28	I	TBR3	See Pin 26 - TBR1.
29	I	TBR4	See Pin 26 - TBR1.
30	I	TBR5	See Pin 26 - TBR1.

PIN	TYPE	SYMBOL	DESCRIPTION
31	I	TBR6	See Pin 26 - TBR1.
32	I	TBR7	See Pin 26 - TBR1.
33	I	TBR8	See Pin 26 - TBR1.
34	I	CRL	A high level on CONTROL REGISTER LOAD loads the control register with the control word. The control word is latched on the falling edge of CRL. See Figure 2.
35	I	PI	A high level on PARITY INHIBIT inhibits parity generation, parity checking and forces PE output low.
36	I	SBS	A high level on STOP BIT SELECT selects 1.5 stop bits for 5 character format and 2 stop bits for other lengths.
37	I	CLS2	These inputs program the CHARACTER LENGTH SELECTED (CLS1 low CLS2 low 5 bits) (CLS1 high CLS2 low 6 bits) (CLS1 low CLS2 high 7 bits) (CLS1 high CLS2 high 8 bits).
38	I	CLS1	See Pin 37 - CLS2.
39	I	EPE	When PI is low, a high level on EVEN PARITY ENABLE generates and checks even parity. A low level selects odd parity.
40	I	TRC	The TRANSMITTER REGISTER CLOCK is 16X the transmit data rate.

HD-6402

T-75-37-05

HD-6402

**Transmitter Operation**

The transmitter section accepts parallel data, formats the data and transmits the data in serial form on the Transmitter Register Output (TRO) terminal (See serial data format). Data is loaded from the inputs TBR1-TBR8 into the Transmitter Buffer Register by applying a logic low on the Transmitter Buffer Register Load (TBRL) input (A). Valid data must be present at least  $t_{set}$  prior to and  $t_{hold}$  following the rising edge of TBRL. If words less than 8 bits are used, only the least significant bits are transmitted. The character is right justified, so the least significant bit corresponds to TBR1 (B).

transferred to the transmitter register, the Transmitter Register Empty (TRE) pin goes to a low state, TBRE is set high and serial data information is transmitted. The output data is clocked by Transmitter Register Clock (TRC) at a clock rate 16 times the data rate. A second low level pulse on TBRL loads data into the Transmitter Buffer Register (C). Data transfer to the transmitter register is delayed until transmission of the current data is complete (D). Data is automatically transferred to the transmitter register and transmission of that character begins one clock cycle later.

The rising edge of TBRL clears Transmitter Buffer Register Empty (TBRE). 0 to 1 Clock cycles later, data is

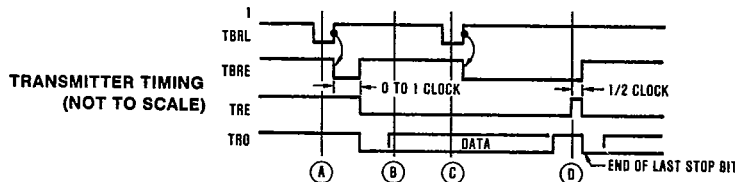

**Receiver Operation**

Data is received in serial form at the Receiver Register Input (RRI). When no data is being received, RRI must remain high. The data is clocked through the Receiver Register Clock (RRC). The clock rate is 16 times the data rate. A low level on Data Received Reset (DRR) clears the Data Receiver (DR) line (A). During the first stop bit data is transferred from the Receiver Register to the Receiver Buffer Register (RBR) (B). If the word is less than 8 bits, the unused most significant bits will be a logic low.

The output character is right justified to the least significant bit RBR1. A logic high on Overrun Error (OE) indicates overruns. An overrun occurs when DR has not been cleared before the present character was transferred to the RBR. One clock cycle later DR is reset to a logic high, and Framing Error (FE) is evaluated (C). A logic high on FE indicates an invalid stop bit was received, a framing error. A logic high on Parity Error (PE) indicates a parity error.

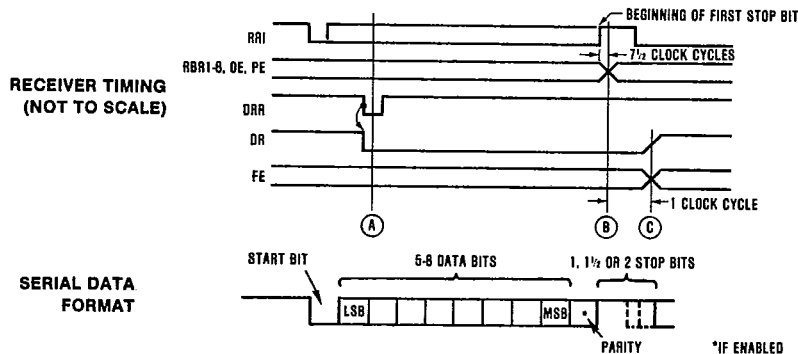

**Start Bit Detection**

The receiver uses a 16X clock timing. The start bit could have occurred as much as one clock cycle before it was detected, as indicated by the shaded portion (A). The center of the start bit is defined as clock count 7 1/2. If the receiver clock is a symmetrical square wave, the center of

the start bit will be located within  $\pm 1/2$  clock cycle,  $\pm 1/32$  bit or 3.125% giving a receiver margin of 46.875%. The receiver begins searching for the next start bit at the center of the first stop bit.

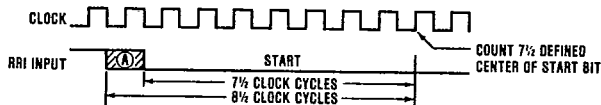

5  
CMOS DATA COMMUNICATIONS

Specifications HD-6402R

T-75-37-05

**Absolute Maximum Ratings**

Supply Voltage .....+8.0 Volts  $\theta_{jc}$  .....25°C/W (CERDIP package)  
 Input, Output or I/O Voltage Applied ..... GND - 0.5V to VCC + 0.5V  $\theta_{ja}$  .....70°C/W (CERDIP package)  
 Storage Temperature Range .....-65°C to +150°C Gate Count .....1,643 Gates  
 Maximum Package Power Dissipation .....1 Watt Junction Temperature .....+150°C  
 Lead Temperature (Soldering, Ten Seconds) .....+275°C

CAUTION: Stresses above those listed in the "Absolute Maximum Ratings" may cause permanent damage to the device. This is a stress only rating and operation of the device at these or any other conditions above those indicated in the operational sections of this specification is not implied.

**Operating Conditions**

Operating Voltage Range	+4.5V to +5.5V
Operating Temperature Ranges	
HD-6402R-9	-40°C to +85°C
HD-6402R-2/-8	-55°C to +125°C

**Electrical Specifications** VCC = 5.0V ± 10%, TA = -40°C to +85°C (HD-6402R-9),  
 TA = -55°C to +125°C (HD-6402R-2/-8)

SYMBOL	PARAMETER	MIN	MAX	UNITS	CONDITIONS
VIH	Logical "1" Input Voltage	2.0		V	HD-6402R-9 HD-6402R-2/-8
		2.2		V	
VIL	Logical "0" Input Voltage		0.8	V	
VIHC	Logical "1" Clock Input Voltage	2.0		V	HD-6402R-9
VILC	Logical "0" Clock Input Voltage	2.2	0.8	V	HD-6402R-2/8
II	Input Leakage	-1.0	1.0	µA	VIN = VCC or GND
VOH	Logical "1" Output Voltage	3.0		V	IOH = -2.5mA IOH = -100µA
		VCC -0.4		V	
VOL	Logical "0" Output Voltage		0.40	V	IOL = +2.5mA
IO	Output Leakage	-1.0	1.0	µA	VO = VCC or GND
ICCSB	Standby Current		100	µA	VIN = GND or VCC VCC = 5.5V, Output Open
ICOP	Operating Supply Current*		2.0	mA	VCC = 5.5V, Clock Freq. = 2MHz, VIN = VCC or GND, Outputs Open.

\*Guaranteed, but not 100% tested.

**Capacitance** TA = 25°C

SYMBOL	PARAMETER	TYPICAL	UNITS	CONDITIONS
CIN	Input Capacitance	8.0	pF	Freq. = 1MHz, all measurements are referenced to device GND
COUT	Output Capacitance	10.0	pF	

**Electrical Specifications** VCC = 5.0V ± 10%, TA = -40°C to +85°C (HD-6402R-9),  
 TA = -55°C to +125°C (HD-6402R-2/-8)

SYMBOL	PARAMETER	MIN	MAX	UNITS	CONDITIONS
(1) fCLOCK	Clock Frequency	D.C.	2.0	MHz	CL = 50pF See Switching Time Waveforms 1, 2, 3
(2) tpw	Pulse Widths CRL, DRR, TBRL	150		ns	
(3) tMR	Pulse Width MR	150		ns	
(4) tSET	Input Data Setup Time	50		ns	
(5) tHOLD	Input Data Hold Time	60		ns	
(6) tEN	Output Enable Time		160	ns	

Specifications HD-6402B

T-75-37-05

HD-6402

**Absolute Maximum Ratings**

Supply Voltage .....	+8.0 Volts	$\theta_{jc}$ .....	25°C/W (CERDIP package)
Input, Output or I/O Voltage Applied .....	GND - 0.5V to VCC + 0.5V	$\theta_{ja}$ .....	70°C/W (CERDIP package)
Storage Temperature Range .....	-65°C to +150°C	Gate Count .....	1,643 Gates
Maximum Package Power Dissipation .....	1 Watt	Junction Temperature .....	+150°C
		Lead Temperature (Soldering, Ten Seconds) .....	+275°C

CAUTION: Stresses above those listed in the "Absolute Maximum Ratings" may cause permanent damage to the device. This is a stress only rating and operation of the device at these or any other conditions above those indicated in the operational sections of this specification is not implied.

**Operating Conditions**

Operating Voltage Range .....	+4.5V to +5.5V
Operating Temperature Ranges	
HD-6402B-9 .....	-40°C to +85°C
HD-6402B-2/-8 .....	-55°C to +125°C

**Electrical Specifications** VCC = 5.0V ± 10%, TA = -40°C to +85°C (HD-6402B-9),  
TA = -55°C to +125°C (HD-6402B-2/-8)

SYMBOL	PARAMETER	MIN	MAX	UNITS	CONDITIONS
VIH	Logical "1" Input Voltage	2.0		V	HD-6402B-9 HD-6402B-2/-8
		2.2		V	
VIL	Logical "0" Input Voltage		0.8	V	
VIHC	Logical "1" Clock Input Voltage	2.0		V	HD-6402B-9
VILC	Logical "0" Clock Input Voltage	2.2	0.8	V	HD-6402B-2/-8
D.C. II	Input Leakage	-1.0	1.0	μA	VIN = VCC or GND
VOH	Logical "1" Output Voltage	3.0		V	IOH = -2.5mA IOH = -100μA
		VCC - 0.4		V	
VOL	Logical "0" Output Voltage		0.40	V	IOL = +2.5mA
IO	Output Leakage	-1.0	1.0	μA	VO = VCC or GND
ICCSB	Standby Current		100	μA	VIN = GND or VCC VCC = 5.5V, Output Open
ICOP	Operating Supply Current*		2.0	mA	VCC = 5.5V, Clock Freq. 2MHz, VIN = VCC or GND Outputs Open

\*Guaranteed but not 100% tested.

**Capacitance** TA = 25°C

SYMBOL	PARAMETER	TYPICAL	UNITS	CONDITIONS
CIN	Input Capacitance	8.0	pF	Freq. = 1MHz, all measurements are referenced to device GND
COUT	Output Capacitance	10.0	pF	

**Electrical Specifications** VCC = 5.0V ± 10%, TA = -40°C to +85°C (HD-6402-9),  
TA = -55°C to +125°C (HD-6402-2/-8)

SYMBOL	PARAMETER	MIN	MAX	UNITS	CONDITIONS
(1) fCLOCK	Clock Frequency	D.C.	8.0	MHz	CL = 50pF See Switching Time Waveforms 1, 2, 3
(2) tpw	Pulse Widths CRL, DRR, TBRL	75		ns	
(3) tMR	Pulse Width MR	150		ns	
(4) tSET	Input Data Setup Time	20		ns	
(5) tHOLD	Input Data Hold Time	20		ns	
(6) tEN	Output Enable Time		35	ns	

5  
CMOS DATA  
COMMUNICATIONS

HD-6402

T-75-37-05

Switching Waveforms

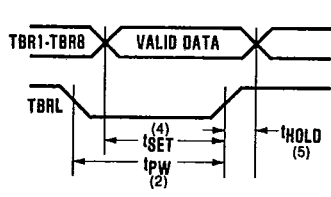

FIGURE 1. DATA INPUT CYCLE

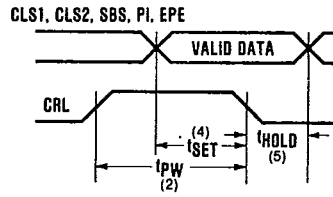

FIGURE 2. CONTROL REGISTER LOAD CYCLE

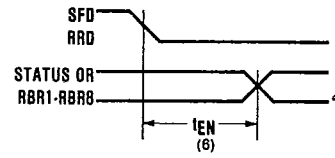
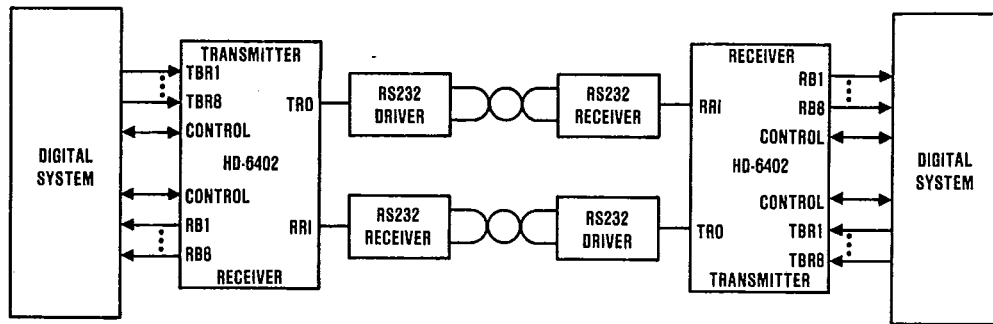

FIGURE 3. STATUS FLAG OUTPUT ENABLE TIME OR DATA OUTPUT ENABLE TIME

Interfacing With The HD-6402



TYPICAL SERIAL DATA LINK

A.C. Testing Input, Output Waveform

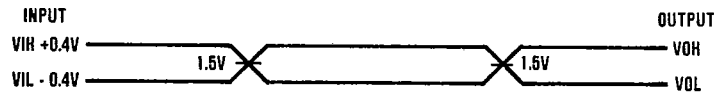

A.C. Testing: All Input signals must switch between VIL - 0.4V and VIH + 0.4V. Input rise and fall times are driven at 1ns/V.