

# 74AUP1T97 TinyLogic® Low Power Configurable Gate with Voltage-Level Translator

## Features

- Single Supply Voltage Translator
  - 1.8V to 3.3V Input at  $V_{CC}=3.3V$
  - 1.8V to 2.5V Input at  $V_{CC}=2.5V$
- 2.3V to 3.6V  $V_{CC}$  Supply Voltage Operation
- 3.6V Over-Voltage Tolerant I/O's at  $V_{CC}$  from 2.3V to 3.6V
- Power-Off High-Impedance Inputs and Outputs
- Low Static Power Consumption
  - $I_{CC}=0.9\mu A$  Maximum
- Low Dynamic Power Consumption
  - $C_{PD}=2.7pF$  Typical at 3.3V
- Ultra-Small MicroPak™ Packages

## Description

The 74AUP1T97 is a universal configurable 2-input logic gate that provides single supply voltage level translation. This device is designed for applications with inputs switching levels that accept 1.8V low voltage CMOS signals while operating from either a single 2.5V or 3.3V supply voltage. The 74AUP1T97 is an ideal low power solution for mixed voltage signal applications especially for battery-powered portable applications. This product guarantees very low static and dynamic power consumption across entire voltage range. All inputs are implemented with hysteresis to allow for slower transition input signals and better switching noise immunity.

The 74AUP1T97 provides for multiple functions as determined by various configurations of the three inputs. The potential logic functions provided are MUX, AND, NAND, OR, and NOR, inverter and buffer. Refer to Figures 3 to 9.

## Ordering Information

| Part Number  | Top Mark | Package                                     | Packing Method            |
|--------------|----------|---|---------------------------|
| 74AUP1T97L6X | AH       | 6-Lead MicroPak™, 1.0mm Wide                | 5000 Units on Tape & Reel |
| 74AUP1T97FHX | AH       | 6-Lead, MicroPak2™, 1x1mm Body, .35mm Pitch | 5000 Units on Tape & Reel |

### Logic Diagram

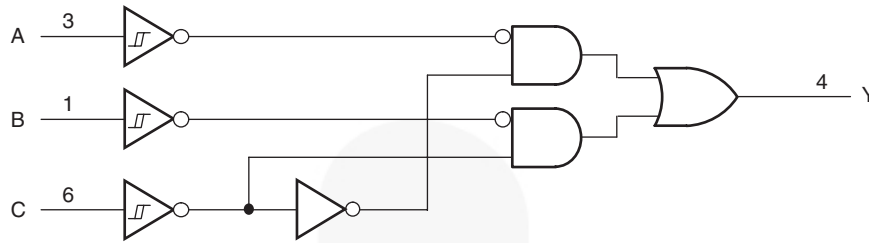

Figure 1. Logic Diagram (Positive Logic)

### Pin Configurations

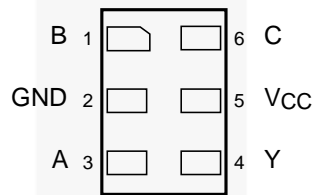

Figure 2. MicroPak™ (Top Through View)

### Pin Definitions

| Pin # | Name            | Description    |
|-------|-----------------|----------------|
| 1     | B               | Data Input     |
| 2     | GND             | Ground         |
| 3     | A               | Data Input     |
| 4     | Y               | Output         |
| 5     | V <sub>CC</sub> | Supply Voltage |
| 6     | C               | Data Input     |

**Function Table**

| Inputs |   |   | 74AUP1T97 |
|--------|---|---|-----------|
| C      | B | A | Y=Output  |
| L      | L | L | L         |
| L      | L | H | L         |
| L      | H | L | H         |
| L      | H | H | H         |
| H      | L | L | L         |
| H      | L | H | H         |
| H      | H | L | L         |
| H      | H | H | H         |

H = HIGH Logic Level

L = LOW Logic Level

**Function Selection Table**

| Logic Function                            | Connection Configuration |
|---|--------------------------|
| 2-to-1 MUX                                | Figure 3                 |
| 2-Input AND Gate                          | Figure 4                 |
| 2-Input OR Gate with One Inverted Input   | Figure 5                 |
| 2-Input NAND Gate with One Inverted Input | Figure 5                 |
| 2-Input AND Gate with One Inverted Input  | Figure 6                 |
| 2-Input NOR Gate with One Inverted Input  | Figure 6                 |
| 2-Input OR Gate                           | Figure 7                 |
| Inverter                                  | Figure 8                 |
| Buffer                                    | Figure 9                 |

## 74AUP1T97 Logic Configurations

Figure 3 through Figure 9 show the logical functions that can be implemented using the 74AUP1T97. The diagrams show the DeMorgan's equivalent logic duals for a given two-input function. The logical

implementation is next to the board-level physical implementation of how the pins of the function should be connected.

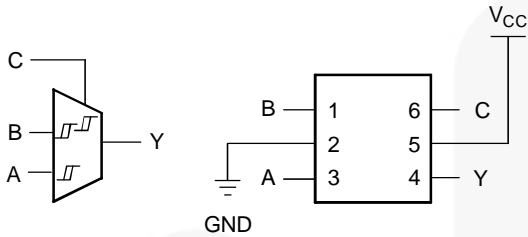

**Note:**

1. When C is L, Y=B.
2. When C is H, Y=A.

**Figure 3. 2-to-1 MUX**

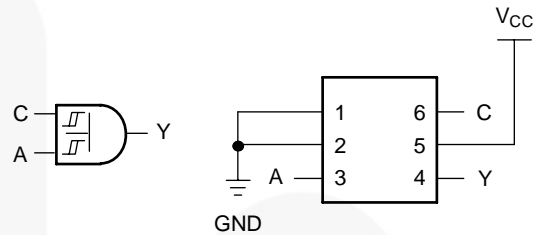

**Figure 4. 2-Input AND Gate**

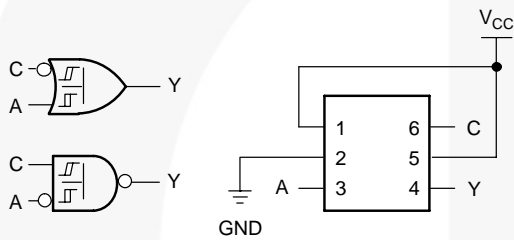

**Figure 5. Input OR Gate with One Inverted Input  
2-Input NAND Gate with One Inverted Input**

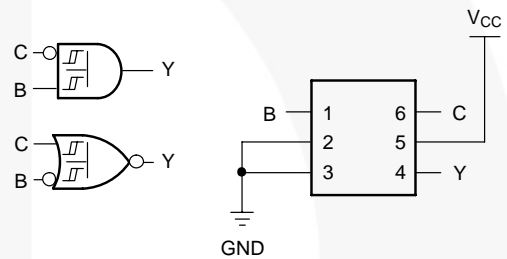

**Figure 6. 2-Input AND Gate with One Inverted Input  
2-Input NOR Gate with One Inverted Input**

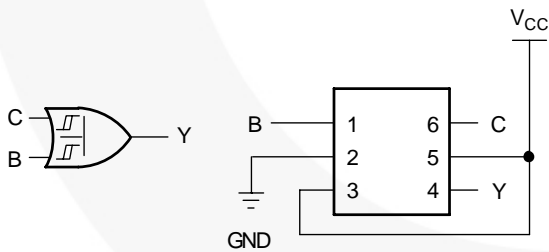

**Figure 7. 2-Input OR Gate**

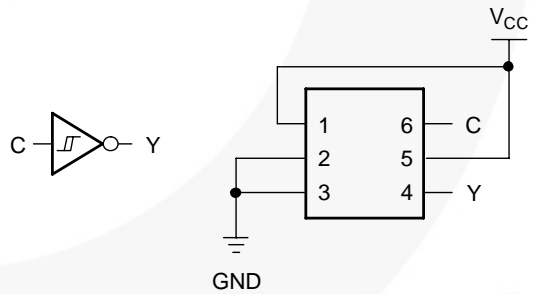

**Figure 8. Inverter**

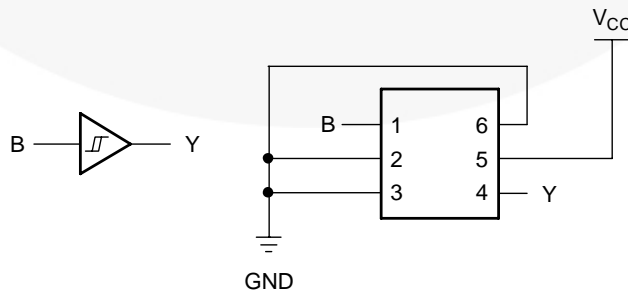

**Figure 9. Buffer**

## Absolute Maximum Ratings

Stresses exceeding the absolute maximum ratings may damage the device. The device may not function or be operable above the recommended operating conditions and stressing the parts to these levels is not recommended. In addition, extended exposure to stresses above the recommended operating conditions may affect device reliability. The absolute maximum ratings are stress ratings only.

| Symbol                | Parameter                                    | Min.                             | Max.           | Unit |
|-----------------------|--|----------------------------------|----------------|------|
| $V_{CC}$              | Supply Voltage                               | -0.5                             | 4.6            | V    |
| $V_{IN}$              | DC Input Voltage                             | -0.5                             | 4.6            | V    |
| $V_{OUT}$             | DC Output Voltage                            | HIGH or LOW State <sup>(3)</sup> | $V_{CC} + 0.5$ | V    |
|                       |  | $V_{CC}=0V$                      | 4.6            |      |
| $I_{IK}$              | DC Input Diode Current                       | $V_{IN} < 0V$                    | -50            | mA   |
| $I_{OK}$              | DC Output Diode Current                      | $V_{OUT} < 0V$                   | -50            | mA   |
|                       |  | $V_{OUT} > V_{CC}$               | +50            |      |
| $I_{OH} / I_{OL}$     | DC Output Source / Sink Current              |                                  | ±50            | mA   |
| $I_o$                 | Continuous Output Current                    |                                  | ±20            | mA   |
| $I_{CC}$ or $I_{GND}$ | DC $V_{CC}$ or Ground Current per Supply Pin |                                  | ±50            | mA   |
| $T_{STG}$             | Storage Temperature Range                    | -65                              | +150           | °C   |
| $T_J$                 | Junction Temperature Under Bias              |                                  | +150           | °C   |
| $T_L$                 | Junction Lead Temperature, Soldering 10s     |                                  | +260           | °C   |
| $P_D$                 | Power Dissipation at +85°C                   | MicroPak-6                       | 130            | mW   |
|                       |  | MicroPak2-6                      | 120            |      |
| ESD                   | Human Body Model, JEDEC:JESD22-A114          |                                  | 5000+          | V    |
|                       | Charged Device Model, JEDEC:JESD22-C101      |                                  | 2000           |      |

### Note:

3.  $I_o$  absolute maximum rating must be observed.

## Recommended Operating Conditions<sup>(4)</sup>

The Recommended Operating Conditions table defines the conditions for actual device operation. Recommended operating conditions are specified to ensure optimal performance to the datasheet specifications. Fairchild does not recommend exceeding them or designing to Absolute Maximum Ratings.

| Symbol          | Parameter                       | Conditions              | Min. | Max.     | Unit |
|-----------------|---------------------------------|-------------------------|------|----------|------|
| $V_{CC}$        | Supply Voltage                  |                         | 2.3  | 3.6      | V    |
| $V_{IN}$        | Input Voltage                   |                         | 0    | 3.6      | V    |
| $V_{OUT}$       | Output Voltage                  | $V_{CC}=0V$             | 0    | 3.6      | V    |
|                 |                                 | HIGH or LOW State       | 0    | $V_{CC}$ |      |
| $I_{OH}/I_{OL}$ | Output Current                  | $V_{CC}=3.0V$ to $3.6V$ |      | ±4.0     | mA   |
|                 |                                 | $V_{CC}=2.3V$ to $2.7V$ |      | ±3.1     |      |
| $T_A$           | Operating Temperature, Free Air |                         | -40  | +85      | °C   |
| $\theta_{JA}$   | Thermal Resistance              | MicroPak-6              |      | 500      | °C/W |
|                 |                                 | MicroPak2-6             |      | 560      |      |

### Note:

4. Unused inputs must be held HIGH or LOW. They may not float.

## DC Electrical Characteristics

| Symbol                 | Parameter                             | V <sub>CC</sub>               | Conditions   | T <sub>A</sub> =+25°C |       | T <sub>A</sub> =-40 to +85°C |       | Units |
|------------------------|---------------------------------------|-------------------------------|--|-----------------------|-------|------------------------------|-------|-------|
|                        |                                       |                               |  | Min.                  | Max.  | Min.                         | Max.  |       |
| V <sub>P</sub>         | Positive Threshold Voltage            | 2.3V to 2.7V                  |  | 0.60                  | 1.10  | 0.60                         | 1.10  | V     |
|                        |                                       | 3.0V to 3.6V                  |  | 0.75                  | 1.16  | 0.75                         | 1.19  |       |
| V <sub>N</sub>         | Negative Threshold Voltage            | 2.3V to 2.7V                  |  | 0.35                  | 0.60  | 0.35                         | 0.60  | V     |
|                        |                                       | 3.0V to 3.6V                  |  | 0.50                  | 0.85  | 0.50                         | 0.85  |       |
| V <sub>H</sub>         | Hysteresis Voltage                    | 2.3V to 2.7V                  |  | 0.23                  | 0.60  | 0.10                         | 0.60  | V     |
|                        |                                       | 3.0V to 3.6V                  |  | 0.25                  | 0.56  | 0.15                         | 0.56  |       |
| V <sub>OH</sub>        | HIGH Level Output Voltage             | 2.3V ≤ V <sub>CC</sub> ≤ 3.6V | I <sub>OH</sub> =-20μA   | V <sub>CC</sub> -0.1  |       | V <sub>CC</sub> -0.1         |       | V     |
|                        |                                       | 2.3V                          | I <sub>OH</sub> =-2.3mA  | 2.05                  |       | 1.97                         |       |       |
|                        |                                       |                               | I <sub>OH</sub> =-3.1mA  | 1.90                  |       | 1.85                         |       |       |
|                        |                                       | 3.0V                          | I <sub>OH</sub> =-2.7mA  | 2.72                  |       | 2.67                         |       |       |
| I <sub>OH</sub> =-4mA  | 2.60                                  |                               |  | 2.55                  |       |                              |       |       |
| V <sub>OL</sub>        | LOW Level Output Voltage              | 2.3V ≤ V <sub>CC</sub> ≤ 3.6V | I <sub>OL</sub> =20μA  |                       | 0.10  |                              | 0.10  | V     |
|                        |                                       | 2.3V                          | I <sub>OL</sub> =2.3mA   |                       | 0.31  |                              | 0.33  |       |
|                        |                                       |                               | I <sub>OL</sub> =3.1mA   |                       | 0.44  |                              | 0.45  |       |
|                        |                                       | 3.0V                          | I <sub>OL</sub> =2.7mA   |                       | 0.31  |                              | 0.33  |       |
| I <sub>OL</sub> =4.0mA |                                       |                               | 0.44   |                       | 0.45  |                              |       |       |
| I <sub>IN</sub>        | Input Leakage Current                 | 0V to 3.6V                    | 0 ≤ V <sub>IN</sub> ≤ 3.6  |                       | ±0.10 |                              | ±0.50 | μA    |
| I <sub>OFF</sub>       | Power Off Leakage Current             | 0V                            | 0 ≤ (V <sub>IN</sub> , V <sub>O</sub> ) ≤ 3.6                    |                       | 0.10  |                              | 0.50  | μA    |
| ΔI <sub>OFF</sub>      | Additional Power Off Leakage Current  | 0V to 0.2V                    | V <sub>IN</sub> or V <sub>O</sub> =0V to 3.6V                    |                       | 0.20  |                              | 0.60  | μA    |
| I <sub>CC</sub>        | Quiescent Supply Current              | 2.3V to 3.6V                  | V <sub>IN</sub> =V <sub>CC</sub> or GND                          |                       | 0.50  |                              | 0.90  | μA    |
|                        |                                       |                               | V <sub>CC</sub> ≤ V <sub>IN</sub> ≤ 3.6V                         |                       |       |                              | ±0.90 |       |
| ΔI <sub>CC</sub>       | Increase in I <sub>CC</sub> per Input | 2.3V to 2.7V                  | One Input at 0.3V or 1.1V, other Inputs at 0 or V <sub>CC</sub>  |                       |       |                              | 4     | μA    |
|                        |                                       | 3.0V to 3.6V                  | One Input at 0.45V or 1.2V, other Inputs at 0 or V <sub>CC</sub> |                       |       |                              | 12    |       |

### AC Electrical Characteristics

| Symbol                              | Parameter         | V <sub>CC</sub>  | Conditions                                | T <sub>A</sub> =+25°C           |      |      | T <sub>A</sub> =-40 to +85°C |      | Units | Figure                 |  |    |  |
|-------------------------------------|-------------------|--|---|---------------------------------|------|------|------------------------------|------|-------|------------------------|--|----|--|
|                                     |                   |  |   | Min.                            | Typ. | Max. | Typ.                         | Max. |       |                        |  |    |  |
| t <sub>PHL</sub> , t <sub>PLH</sub> | Propagation Delay | 2.30V ≤ V <sub>CC</sub> ≤ 2.70V, V <sub>IN</sub> =1.65V to 1.95V | C <sub>L</sub> =5pF, R <sub>L</sub> =1MΩ  | 1.1                             | 3.7  | 5.5  | 1.1                          | 6.8  | ns    | Figure 10<br>Figure 11 |  |    |  |
|                                     |                   | 2.30V ≤ V <sub>CC</sub> ≤ 2.70V, V <sub>IN</sub> =2.30V to 2.70V |   | 1.1                             | 3.8  | 6.5  | 1.1                          | 7.0  |       |                        |  |    |  |
|                                     |                   | 2.30V ≤ V <sub>CC</sub> ≤ 2.70V, V <sub>IN</sub> =3.0V to 3.60V  |   | 1.1                             | 3.9  | 6.0  | 1.1                          | 6.5  |       |                        |  |    |  |
|                                     |                   | 3.00V ≤ V <sub>CC</sub> ≤ 3.60V, V <sub>IN</sub> =1.65V to 1.95V |   | 1.0                             | 3.3  | 4.9  | 1.0                          | 8.0  |       |                        |  |    |  |
|                                     |                   | 3.00V ≤ V <sub>CC</sub> ≤ 3.60V, V <sub>IN</sub> =2.30V to 2.70V |   | 1.0                             | 3.2  | 4.6  | 1.0                          | 5.8  |       |                        |  |    |  |
|                                     |                   | 3.00V ≤ V <sub>CC</sub> ≤ 3.60V, V <sub>IN</sub> =3.00V to 3.60V |   | 1.0                             | 3.1  | 4.7  | 1.0                          | 5.5  |       |                        |  |    |  |
|                                     |                   | 2.30V ≤ V <sub>CC</sub> ≤ 2.70V, V <sub>IN</sub> =1.65V to 1.95V | C <sub>L</sub> =10pF, R <sub>L</sub> =1MΩ | 1.3                             | 4.1  | 6.5  | 1.0                          | 7.9  |       |                        |  |    |  |
|                                     |                   | 2.30V ≤ V <sub>CC</sub> ≤ 2.70V, V <sub>IN</sub> =2.30V to 2.70V |   | 1.3                             | 4.0  | 6.2  | 1.0                          | 7.1  |       |                        |  |    |  |
|                                     |                   | 2.30V ≤ V <sub>CC</sub> ≤ 2.70V, V <sub>IN</sub> =3.0V to 3.60V  |   | 1.3                             | 3.7  | 5.7  | 1.0                          | 6.5  |       |                        |  |    |  |
|                                     |                   | 3.00V ≤ V <sub>CC</sub> ≤ 3.60V, V <sub>IN</sub> =1.65V to 1.95V |   | 1.3                             | 3.5  | 5.6  | 1.0                          | 8.5  |       |                        |  |    |  |
|                                     |                   | 3.00V ≤ V <sub>CC</sub> ≤ 3.60V, V <sub>IN</sub> =2.30V to 2.70V |   | 1.3                             | 3.4  | 5.3  | 1.0                          | 6.1  |       |                        |  |    |  |
|                                     |                   | 3.00V ≤ V <sub>CC</sub> ≤ 3.60V, V <sub>IN</sub> =3.00V to 3.60V |   | 1.3                             | 3.3  | 5.2  | 1.0                          | 5.9  |       |                        |  |    |  |
|                                     |                   | 2.30V ≤ V <sub>CC</sub> ≤ 2.70V, V <sub>IN</sub> =1.65V to 1.95V | C <sub>L</sub> =15pF, R <sub>L</sub> =1MΩ | 1.5                             | 4.6  | 6.9  | 1.0                          | 8.7  |       |                        |  |    |  |
|                                     |                   | 2.30V ≤ V <sub>CC</sub> ≤ 2.70V, V <sub>IN</sub> =2.30V to 2.70V |   | 1.5                             | 4.4  | 6.8  | 1.0                          | 7.9  |       |                        |  |    |  |
|                                     |                   | 2.30V ≤ V <sub>CC</sub> ≤ 2.70V, V <sub>IN</sub> =3.0V to 3.60V  |   | 1.5                             | 4.2  | 6.3  | 1.0                          | 7.4  |       |                        |  |    |  |
|                                     |                   | 3.00V ≤ V <sub>CC</sub> ≤ 3.60V, V <sub>IN</sub> =1.65V to 1.95V |   | 1.3                             | 3.9  | 6.2  | 1.0                          | 9.1  |       |                        |  |    |  |
|                                     |                   | 3.00V ≤ V <sub>CC</sub> ≤ 3.60V, V <sub>IN</sub> =2.30V to 2.70V |   | 1.3                             | 3.8  | 5.6  | 1.0                          | 6.8  |       |                        |  |    |  |
|                                     |                   | 3.00V ≤ V <sub>CC</sub> ≤ 3.60V, V <sub>IN</sub> =3.00V to 3.60V |   | 1.3                             | 3.8  | 5.6  | 1.0                          | 6.2  |       |                        |  |    |  |
|                                     |                   | 2.30V ≤ V <sub>CC</sub> ≤ 2.70V, V <sub>IN</sub> =1.65V to 1.95V | C <sub>L</sub> =30pF, R <sub>L</sub> =1MΩ | 1.3                             | 4.2  | 7.9  | 1.3                          | 8.5  |       |                        |  |    |  |
|                                     |                   | 2.30V ≤ V <sub>CC</sub> ≤ 2.70V, V <sub>IN</sub> =2.30V to 2.70V |   | 1.3                             | 3.9  | 7.9  | 1.3                          | 8.5  |       |                        |  |    |  |
|                                     |                   | 2.30V ≤ V <sub>CC</sub> ≤ 2.70V, V <sub>IN</sub> =3.0V to 3.60V  |   | 1.0                             | 3.7  | 7.3  | 1.0                          | 8.9  |       |                        |  |    |  |
|                                     |                   | 3.00V ≤ V <sub>CC</sub> ≤ 3.60V, V <sub>IN</sub> =1.65V to 1.95V |   | 1.3                             | 3.5  | 6.1  | 1.3                          | 7.9  |       |                        |  |    |  |
|                                     |                   | 3.00V ≤ V <sub>CC</sub> ≤ 3.60V, V <sub>IN</sub> =2.30V to 2.70V |   | 1.1                             | 3.0  | 5.9  | 1.1                          | 6.8  |       |                        |  |    |  |
|                                     |                   | 3.00V ≤ V <sub>CC</sub> ≤ 3.60V, V <sub>IN</sub> =3.00V to 3.60V |   | 1.0                             | 2.7  | 5.7  | 1.0                          | 6.5  |       |                        |  |    |  |
|                                     |                   | C <sub>IN</sub>  | Input Capacitance                         | 0                               |      | 2.1  |                              |      |       |                        |  | pF |  |
|                                     |                   | C <sub>OUT</sub>   | Output Capacitance                        | 0                               |      | 3.0  |                              |      |       |                        |  | pF |  |
|                                     |                   | C <sub>PD</sub>  | Power Dissipation Capacitance             | 2.30V ≤ V <sub>CC</sub> ≤ 2.70V |      | 2.0  |                              |      |       |                        |  | pF |  |
|                                     |                   |  |   | 3.00V ≤ V <sub>CC</sub> ≤ 3.60V |      | 2.7  |                              |      |       |                        |  |    |  |

## AC Loadings and Waveforms

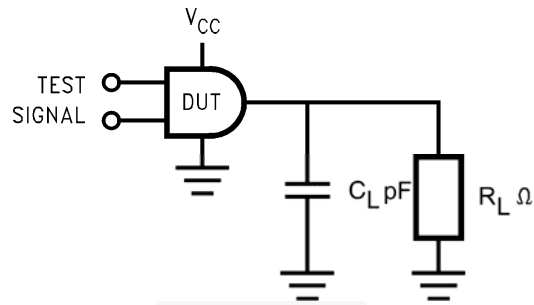

Figure 10. AC Test Circuit

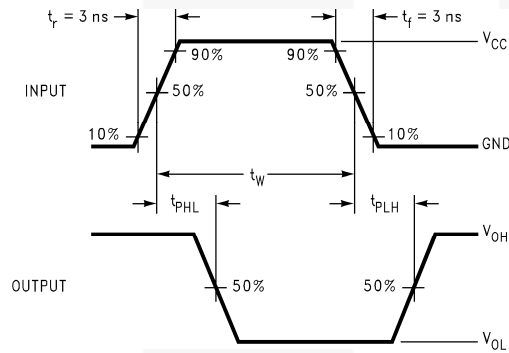
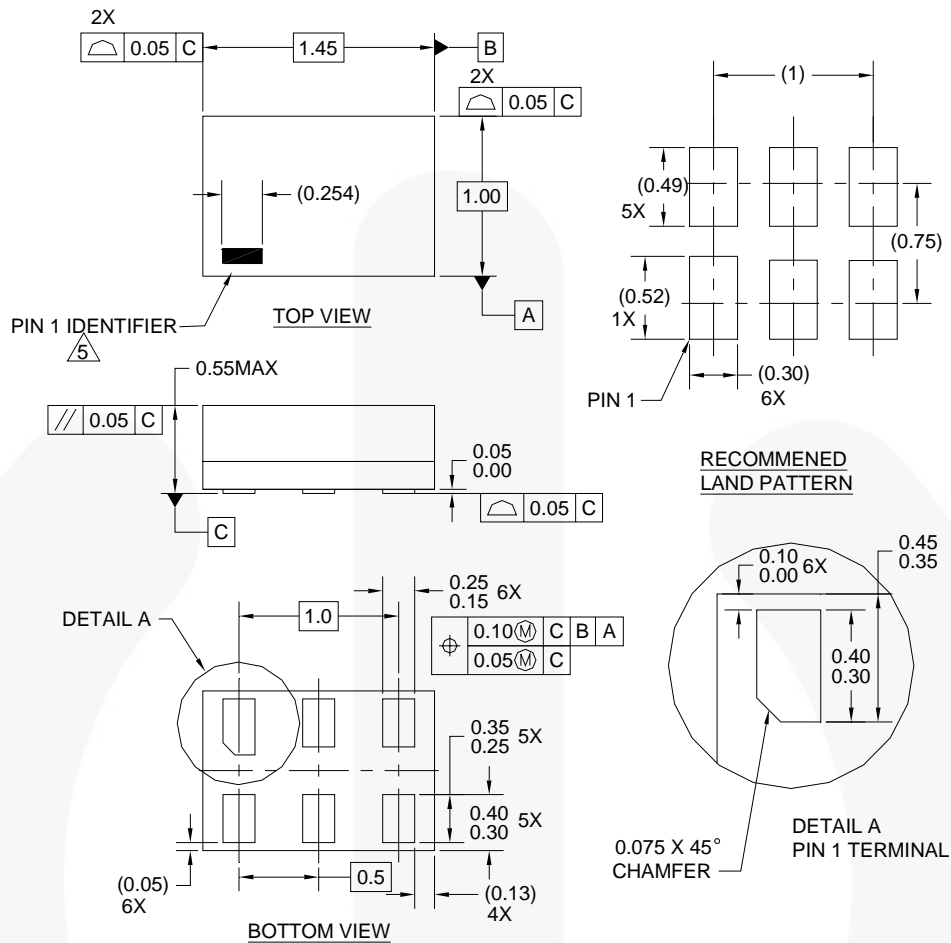

Figure 11. AC Waveforms

| Symbol   | $V_{CC}$        |                 |
|----------|-----------------|-----------------|
|          | $3.3V \pm 0.3V$ | $2.5V \pm 0.2V$ |
| $V_{mi}$ | $V_{IN}/2$      | $V_{IN}/2$      |
| $V_{mo}$ | $V_{CC}/2$      | $V_{CC}/2$      |



## Physical Dimensions



**Notes:**

1. CONFORMS TO JEDEC STANDARD M0-252 VARIATION UAAD
2. DIMENSIONS ARE IN MILLIMETERS
3. DRAWING CONFORMS TO ASME Y14.5M-1994
4. FILENAME AND REVISION: MAC06AREV4
- △5. PIN ONE IDENTIFIER IS 2X LENGTH OF ANY OTHER LINE IN THE MARK CODE LAYOUT.

**Figure 12. 6-Lead, MicroPak™, 1.0mm Wide**

Package drawings are provided as a service to customers considering Fairchild components. Drawings may change in any manner without notice. Please note the revision and/or date on the drawing and contact a Fairchild Semiconductor representative to verify or obtain the most recent revision. Package specifications do not expand the terms of Fairchild's worldwide terms and conditions, specifically the warranty therein, which covers Fairchild products.

Always visit Fairchild Semiconductor's online packaging area for the most recent package drawings:  
<http://www.fairchildsemi.com/packaging/>.

## Tape and Reel Specifications

Please visit Fairchild Semiconductor's online packaging area for the most recent tape and reel specifications:  
[http://www.fairchildsemi.com/products/logic/pdf/micropak\\_tr.pdf](http://www.fairchildsemi.com/products/logic/pdf/micropak_tr.pdf).

| Package Designator | Tape Section       | Cavity Number | Cavity Status | Cover Type Status |
|--------------------|--------------------|---------------|---------------|-------------------|
| L6X                | Leader (Start End) | 125 (Typical) | Empty         | Sealed            |
|                    | Carrier            | 5000          | Filled        | Sealed            |
|                    | Trailer (Hub End)  | 75 (Typical)  | Empty         | Sealed            |

## Physical Dimensions

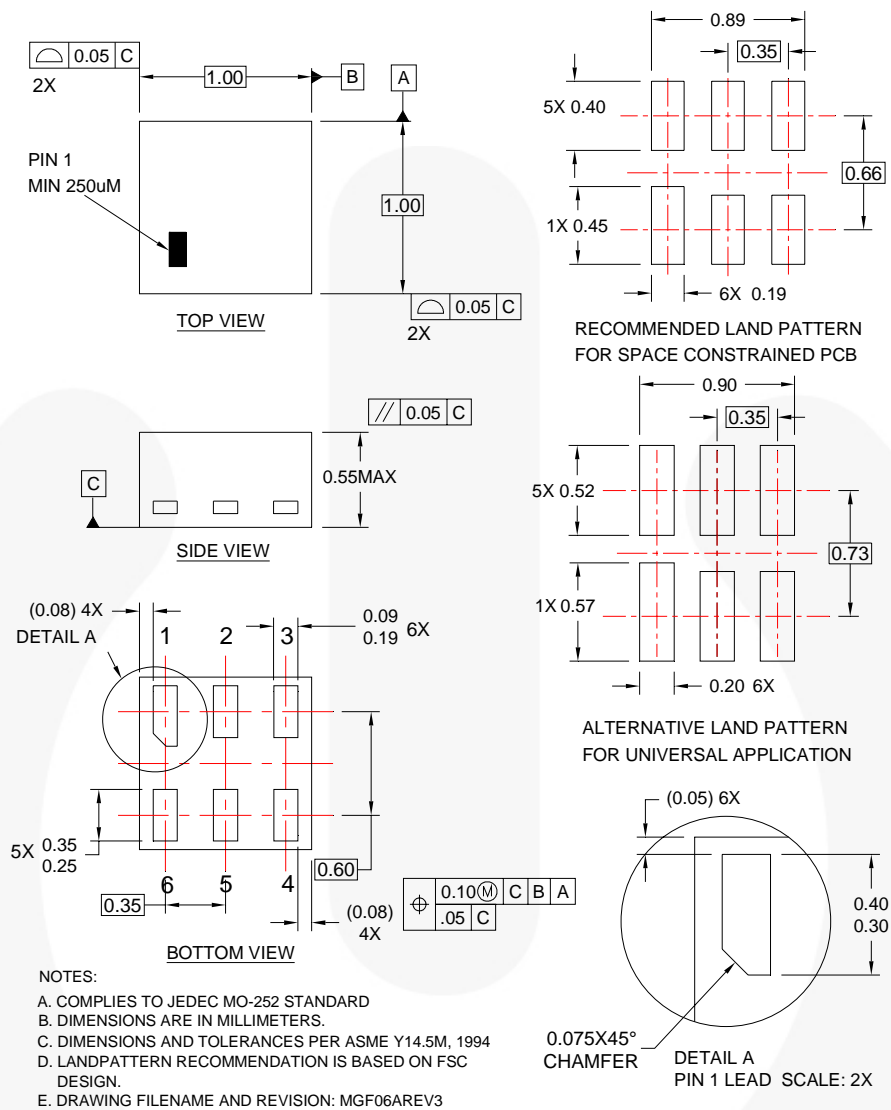

**Figure 13. 6-Lead, MicroPak2™, 1x1mm Body, .35mm Pitch**

Package drawings are provided as a service to customers considering Fairchild components. Drawings may change in any manner without notice. Please note the revision and/or date on the drawing and contact a Fairchild Semiconductor representative to verify or obtain the most recent revision. Package specifications do not expand the terms of Fairchild's worldwide terms and conditions, specifically the warranty therein, which covers Fairchild products.

Always visit Fairchild Semiconductor's online packaging area for the most recent package drawings:  
<http://www.fairchildsemi.com/packaging/>.

## Tape and Reel Specifications

Please visit Fairchild Semiconductor's online packaging area for the most recent tape and reel specifications:  
[http://www.fairchildsemi.com/packaging/MicroPAK2\\_6L\\_tr.pdf](http://www.fairchildsemi.com/packaging/MicroPAK2_6L_tr.pdf).

| Package Designator | Tape Section       | Cavity Number | Cavity Status | Cover Type Status |
|--------------------|--------------------|---------------|---------------|-------------------|
| FHX                | Leader (Start End) | 125 (Typical) | Empty         | Sealed            |
|                    | Carrier            | 5000          | Filled        | Sealed            |
|                    | Trailer (Hub End)  | 75 (Typical)  | Empty         | Sealed            |



**TRADEMARKS**

The following includes registered and unregistered trademarks and service marks, owned by Fairchild Semiconductor and/or its global subsidiaries, and is not intended to be an exhaustive list of all such trademarks.

AccuPower™  
Auto-SPM™  
Build it Now™  
CorePLUS™  
CorePOWER™  
CROSSVOLT™  
CTL™  
Current Transfer Logic™  
DEUXPEED®  
Dual Cool™  
EcoSPARK®  
EfficientMax™  
ESBC™  
**F**®  
Fairchild®  
Fairchild Semiconductor®  
FACT Quiet Series™  
FACT®  
FAST®  
FastvCore™  
FETBench™  
FlashWriter®  
FPS™

F-PFS™  
FRFET®  
Global Power Resource<sup>SM</sup>  
Green FPST™  
Green FPST™ e-Series™  
Gmax™  
GTO™  
IntelliMAX™  
ISOPLANAR™  
MegaBuck™  
MICROCOUPLER™  
MicroFET™  
MicroPak™  
MicroPak2™  
MillerDrive™  
MotionMax™  
Motion-SPM™  
OptoHIT™  
OPTOLOGIC®  
OPTOPLANAR®  
  
PDP SPM™

Power-SPM™  
PowerTrench®  
PowerXS™  
Programmable Active Droop™  
QFET®  
QS™  
Quiet Series™  
RapidConfigure™  
™  
Saving our world, 1mW/WkW at a time™  
SignalWise™  
SmartMax™  
SMART START™  
SPM®  
STEALTH™  
SuperFET®  
SuperSOT™.3  
SuperSOT™.6  
SuperSOT™.8  
SupreMOS®  
SyncFET™  
Sync-Lock™

**SYSTEM**  
GENERAL  
The Power Franchise®  
**the power franchise**  
TinyBoost™  
TinyBuck™  
TinyCalc™  
TinyLogic®  
TINYOPTO™  
TinyPower™  
TinyPVM™  
TinyWire™  
TriFault Detect™  
TRUECURRENT™  
µSerDes™  
 SerDes  
UHC®  
Ultra FRFET™  
UniFET™  
VCX™  
VisualMax™  
XS™

\* Trademarks of System General Corporation, used under license by Fairchild Semiconductor.

**DISCLAIMER**

FAIRCHILD SEMICONDUCTOR RESERVES THE RIGHT TO MAKE CHANGES WITHOUT FURTHER NOTICE TO ANY PRODUCTS HEREIN TO IMPROVE RELIABILITY, FUNCTION, OR DESIGN. FAIRCHILD DOES NOT ASSUME ANY LIABILITY ARISING OUT OF THE APPLICATION OR USE OF ANY PRODUCT OR CIRCUIT DESCRIBED HEREIN; NEITHER DOES IT CONVEY ANY LICENSE UNDER ITS PATENT RIGHTS, NOR THE RIGHTS OF OTHERS. THESE SPECIFICATIONS DO NOT EXPAND THE TERMS OF FAIRCHILD'S WORLDWIDE TERMS AND CONDITIONS, SPECIFICALLY THE WARRANTY THEREIN, WHICH COVERS THESE PRODUCTS.

**LIFE SUPPORT POLICY**

FAIRCHILD'S PRODUCTS ARE NOT AUTHORIZED FOR USE AS CRITICAL COMPONENTS IN LIFE SUPPORT DEVICES OR SYSTEMS WITHOUT THE EXPRESS WRITTEN APPROVAL OF FAIRCHILD SEMICONDUCTOR CORPORATION.

As used herein:

1. Life support devices or systems are devices or systems which, (a) are intended for surgical implant into the body or (b) support or sustain life, and (c) whose failure to perform when properly used in accordance with instructions for use provided in the labeling, can be reasonably expected to result in a significant injury of the user.
2. A critical component in any component of a life support, device, or system whose failure to perform can be reasonably expected to cause the failure of the life support device or system, or to affect its safety or effectiveness.

**ANTI-COUNTERFEITING POLICY**

Fairchild Semiconductor Corporation's Anti-Counterfeiting Policy. Fairchild's Anti-Counterfeiting Policy is also stated on our external website, [www.fairchildsemi.com](http://www.fairchildsemi.com), under Sales Support.

Counterfeiting of semiconductor parts is a growing problem in the industry. All manufacturers of semiconductor products are experiencing counterfeiting of their parts. Customers who inadvertently purchase counterfeit parts experience many problems such as loss of brand reputation, substandard performance, failed applications, and increased cost of production and manufacturing delays. Fairchild is taking strong measures to protect ourselves and our customers from the proliferation of counterfeit parts. Fairchild strongly encourages customers to purchase Fairchild parts either directly from Fairchild or from Authorized Fairchild Distributors who are listed by country on our web page cited above. Products customers buy either from Fairchild directly or from Authorized Fairchild Distributors are genuine parts, have full traceability, meet Fairchild's quality standards for handling and storage and provide access to Fairchild's full range of up-to-date technical and product information. Fairchild and our Authorized Distributors will stand behind all warranties and will appropriately address any warranty issues that may arise. Fairchild will not provide any warranty coverage or other assistance for parts bought from Unauthorized Sources. Fairchild is committed to combat this global problem and encourage our customers to do their part in stopping this practice by buying direct or from authorized distributors.

**PRODUCT STATUS DEFINITIONS**

**Definition of Terms**

| Datasheet Identification | Product Status        | Definition  |
|--------------------------|-----------------------|---|
| Advance Information      | Formative / In Design | Datasheet contains the design specifications for product development. Specifications may change in any manner without notice.   |
| Preliminary              | First Production      | Datasheet contains preliminary data; supplementary data will be published at a later date. Fairchild Semiconductor reserves the right to make changes at any time without notice to improve design. |
| No Identification Needed | Full Production       | Datasheet contains final specifications. Fairchild Semiconductor reserves the right to make changes at any time without notice to improve the design.   |
| Obsolete                 | Not In Production     | Datasheet contains specifications on a product that is discontinued by Fairchild Semiconductor. The datasheet is for reference information only.  |

Rev. I50