

100325

Low Power Hex ECL-to-TTL Translator

General Description

The 100325 is a hex translator for converting F100K logic levels to TTL logic levels. Differential inputs allow each circuit to be used as an inverting, non-inverting or differential receiver. An internal reference voltage generator provides V_{BB} for single-ended operation, or for use in Schmitt trigger applications. All inputs have 50 k Ω pull-down resistors. When the inputs are either unconnected or at the same potential the outputs will go low.

When used in single-ended operation the apparent input threshold of the true inputs is 20 mV to 40 mV higher (positive) than the threshold of the complementary inputs. The V_{EE} and V_{TTL} power may be applied in either order.

Features

- Pin/function compatible with 100125
- Meets 100125 AC specifications
- 50% power reduction of the 100125
- Differential inputs with built in offset
- Standard FAST[®] outputs
- 2000V ESD protection
- -4.2V to -5.7V operating range
- Available to Microcircuit Drawing (SMD) 5962-9153101

Logic Diagram

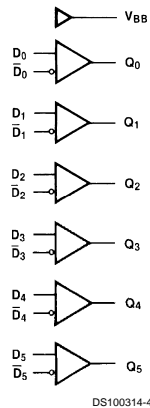

Pin Names	Description
D_0 – D_5	Data Inputs
\bar{D}_0 – \bar{D}_5	Inverting Data Inputs
Q_0 – Q_5	Data Outputs

Connection Diagrams

24-Pin DIP

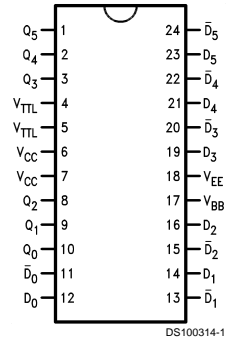

24-Pin Quad Cerpak

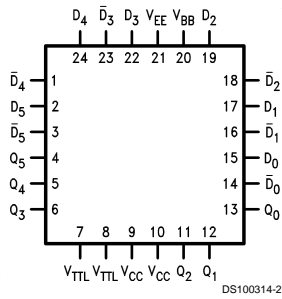

Truth Table

Inputs		Outputs
D_n	\bar{D}_n	Q_n
L	H	L
H	L	H
L	L	L
H	H	L
Open	Open	L
V_{EE}	V_{EE}	L
L	V_{BB}	L
H	V_{BB}	H
V_{BB}	L	H
V_{BB}	H	L

H = HIGH Voltage Level
L = LOW Voltage Level

Absolute Maximum Ratings (Note 1)

If Military/Aerospace specified devices are required, please contact the National Semiconductor Sales Office/Distributors for availability and specifications.

Above which the useful life may be impaired.

Storage Temperature (T_{STG})	-65°C to +150°C
Maximum Junction Temperature (T_J)	
Ceramic	+175°C
V_{EE} Pin Potential to Ground Pin	-7.0V to +0.5V
V_{TTL} Pin Potential to Ground Pin	-0.5V to +6.0V
Input Voltage (DC)	V_{EE} to +0.5V

Voltage Applied to Output	
in HIGH State (with $V_{CC} = 0V$)	-0.5V to V_{CC}
Current Applied to Output	
in LOW State (Max)	twice the rated I_{OL} (mA)
ESD (Note 2)	$\geq 2000V$

Recommended Operating Conditions

Case Temperature (T_C)	
Military	-55°C to +125°C
Supply Voltage (V_{EE})	-5.7V to -4.2V

Note 1: Absolute maximum ratings are those values beyond which the device may be damaged or have its useful life impaired. Functional operation under these conditions is not implied.

Note 2: ESD testing conforms to MIL-STD-883, Method 3015.

Military Version

DC Electrical Characteristics

$V_{EE} = -4.2V$ to $-5.7V$, $V_{CC} = V_{CCA} = GND$, $T_C = -55^\circ C$ to $+125^\circ C$, $C_L = 50$ pF, $V_{TTL} = +4.5V$ to $+5.5V$

Symbol	Parameter	Min	Max	Units	T_C	Conditions	Notes	
V_{BB}	Output Reference Voltage	-1380	-1260	mV	0°C to +125°C	$I_{V_{BB}} = -3 \mu A$, $V_{EE} = -4.2V$	(Notes 3, 4, 5)	
		-1396	-1260		-55°C	$I_{V_{BB}} = -2.1$ mA		$V_{EE} = -5.7V$
					-55°C	$I_{V_{BB}} = -3$ mA		
V_{IH}	Input HIGH Voltage	-1165	-870	mV	-55°C to +125°C	Guaranteed HIGH Signal for All Inputs (with One Input Tied to V_{BB})	(Notes 3, 4, 5, 6)	
V_{IL}	Input LOW Voltage	-1830	-1475	mV	-55°C to +125°C	Guaranteed LOW Signal for All Inputs (with One Input Tied to V_{BB})	(Notes 3, 4, 5, 6)	
V_{OH}	Output HIGH Voltage	2.5		mV	0°C to +125°C	$I_{OH} = -2.0$ mA	$V_{IN} = V_{IH (Max)}$ or $V_{IL (Min)}$	(Notes 3, 4, 5)
		2.4			-55°C			
V_{OL}	Output LOW Voltage		0.5	mV	-55°C to +125°C	$I_{OL} = 20$ mA		
V_{DIFF}	Input Voltage Differential	150		mV	-55°C to +125°C	Required for Full Output Swing	(Notes 3, 4, 5)	
V_{CM}	Common Mode Voltage	-2000	-500	mV	-55°C to +125°C		(Notes 3, 4, 5, 6)	
I_{IH}	Input HIGH Current		350	μA	0°C to +125°C	$V_{IN} = V_{IH (Max)}$, $D_0-D_5 = V_{BB}$, $\bar{D}_0-\bar{D}_5 = V_{IL (Min)}$	(Notes 3, 4, 5)	
			500		-55°C			
I_{IL}	Input LOW Current	0.50		μA	-55°C to +125°C	$V_{IN} = V_{IL (Min)}$, $D_0-D_5 = V_{BB}$	(Notes 3, 4, 5)	
I_{OS}	Output Short Circuit Current	-150	-60	mA	-55°C to +125°C	$V_{OUT} = GND$ Test One Output at a Time	(Notes 3, 4, 5)	
I_{CEX}	Output HIGH Leakage Current		250	μA	-55°C to +125°C	$V_{OUT} = 5.5V$	(Notes 3, 4, 5)	
I_{EE}	V_{EE} Power Supply Current	-35	-12	mA	-55°C to +125°C	$D_0-D_5 = V_{BB}$	(Notes 3, 4, 5)	
I_{TTL}	V_{TTL} Power Supply Current		65	mA	-55°C to +125°C	$D_0-D_5 = V_{BB}$	(Notes 3, 4, 5)	

Note 3: F100K 300 Series cold temperature testing is performed by temperature soaking (to guarantee junction temperature equals -55°C), then testing immediately without allowing for the junction temperature to stabilize due to heat dissipation after power-up. This provides "cold start" specs which can be considered a worst case condition at cold temperatures.

Note 4: Screen tested 100% on each device at -55°C, +25°C, and +125°C, Subgroups 1, 2, 3, 7, and 8.

Note 5: Sample tested (Method 5005, Table I) on each manufactured lot at -55°C, +25°C, and +125°C, Subgroups A1, 2, 3, 7, and 8.

Note 6: Guaranteed by applying specified input condition and testing V_{OH}/V_{OL} .

AC Electrical Characteristics

$V_{EE} = -4.2V$ to $-5.7V$; $V_{CC} = GND$; $V_{TTL} = +4.5V$ to $+5.5V$

Symbol	Parameter	$T_C = -55^\circ C$		$T_C = +25^\circ C$		$T_C = +125^\circ C$		Units	Conditions	Notes
		Min	Max	Min	Max	Min	Max			
t_{PLH}	Propagation Delay	1.50	5.00	1.60	4.70	1.70	5.70	ns	$C_L = 50$ pF	(Notes 7, 8, 9)
t_{PHL}	Data to Output								Figures 1, 3	

Note 7: F100K 300 Series cold temperature testing is performed by temperature soaking (to guarantee junction temperature equals $-55^\circ C$), then testing immediately after power-up. This provides "cold start" specs which can be considered a worst case condition at cold temperatures.

Note 8: Screen tested 100% on each device at $+25^\circ C$, temperature only, Subgroup A9.

Note 9: Sample tested (Method 5005, Table I) on each manufactured lot at $+25^\circ C$, Subgroup A9, and at $+125^\circ C$ and $-55^\circ C$ temperatures, Subgroups A10 and A11.

Note 10: Not tested at $+25^\circ C$, $+125^\circ C$, and $-55^\circ C$ temperature (design characterization data).

Switching Waveform

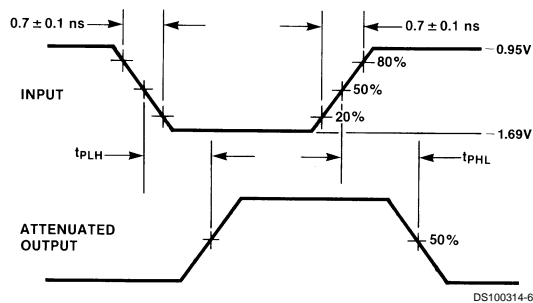
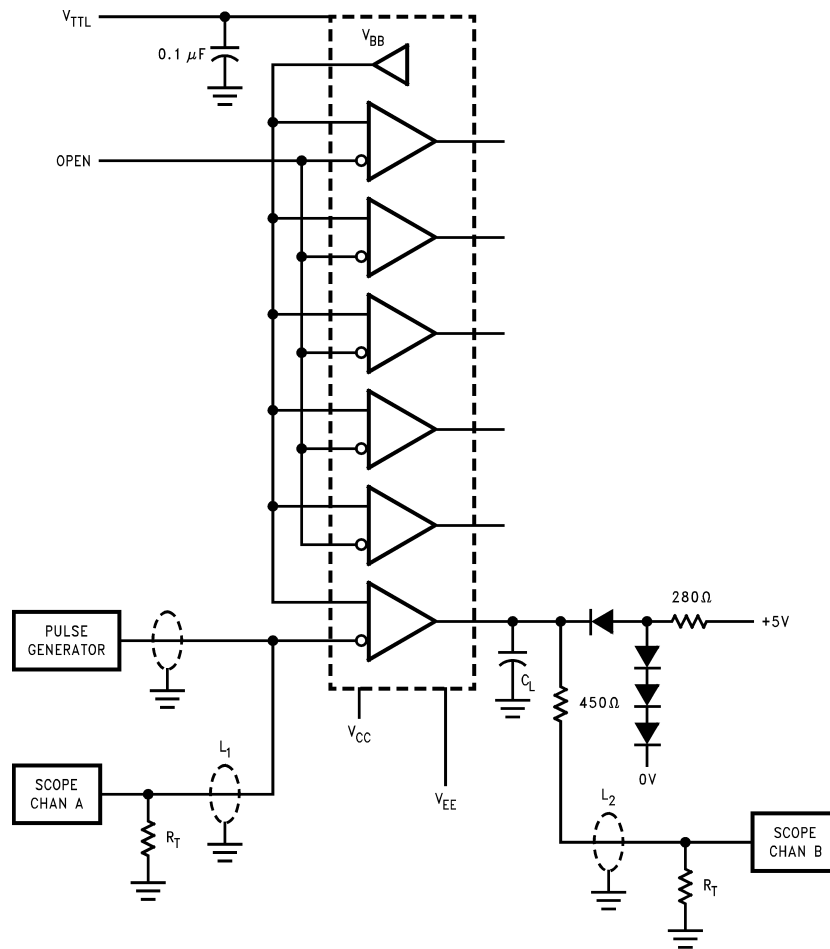

FIGURE 1. Propagation Delay

Test Circuits



DS100314-5

Notes:

$V_{CC} = 0V$, $V_{EE} = -4.5V$, $V_{TTL} = +5V$
 L_1 and L_2 = equal length 50Ω impedance lines
 $R_T = 50\Omega$ terminator internal to scope
 Decoupling $0.1\ \mu F$ from GND to V_{CC} , V_{EE} and V_{TTL}
 All unused outputs are loaded with 500Ω to GND
 C_L = Fixture and stray capacitance = $15\ pF$

FIGURE 2. AC Test Circuit for 15 pF Loading

Test Circuits (Continued)

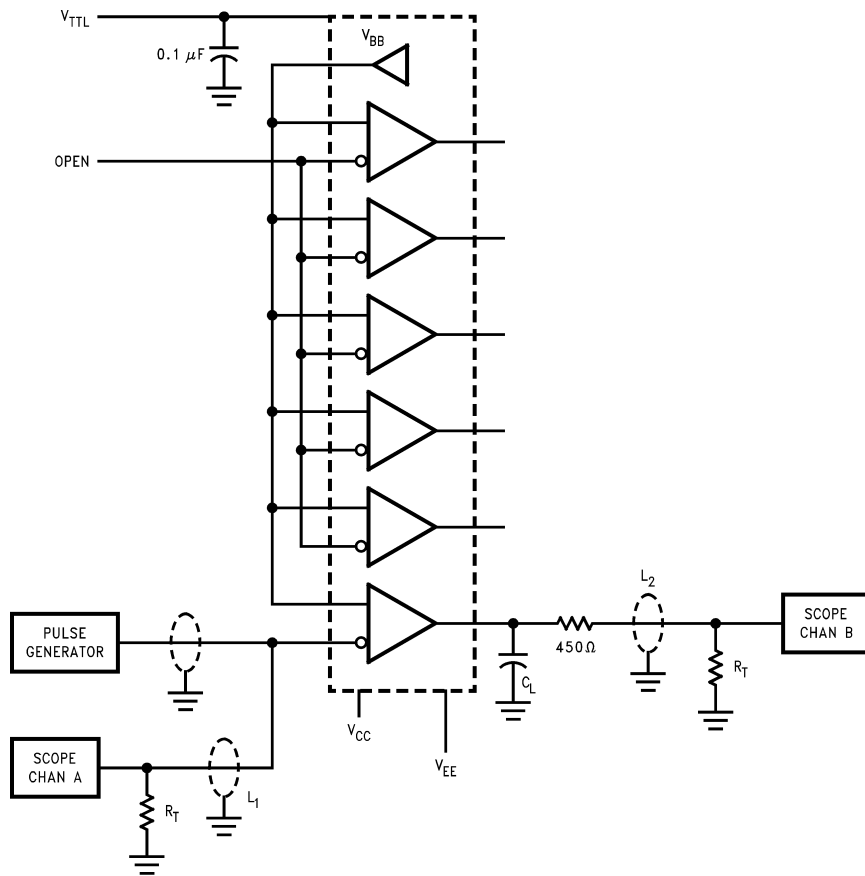

DS100314-8

Notes:

- $V_{CC} = 0V$, $V_{EE} = -4.5V$, $V_{TTL} = +5V$
- L_1 and L_2 = equal length 50Ω impedance lines
- $R_T = 50\Omega$ terminator internal to scope
- Decoupling 0.1 μF from GND to V_{CC} , V_{EE} and V_{TTL}
- All unused outputs are loaded with 500Ω to GND
- C_L = Fixture and stray capacitance = 50 pF

FIGURE 3. AC Test Circuit for 50 pF Loading

LIFE SUPPORT POLICY

NATIONAL'S PRODUCTS ARE NOT AUTHORIZED FOR USE AS CRITICAL COMPONENTS IN LIFE SUPPORT DEVICES OR SYSTEMS WITHOUT THE EXPRESS WRITTEN APPROVAL OF THE PRESIDENT OF NATIONAL SEMICONDUCTOR CORPORATION. As used herein:

1. Life support devices or systems are devices or systems which, (a) are intended for surgical implant into the body, or (b) support or sustain life, and whose failure to perform when properly used in accordance with instructions for use provided in the labeling, can be reasonably expected to result in a significant injury to the user.
2. A critical component in any component of a life support device or system whose failure to perform can be reasonably expected to cause the failure of the life support device or system, or to affect its safety or effectiveness.



National Semiconductor Corporation
Americas
Tel: 1-800-272-9959
Fax: 1-800-737-7018
Email: support@nsc.com

www.national.com

National Semiconductor Europe
Fax: +49 (0) 1 80-530 85 86
Email: europe.support@nsc.com
Deutsch Tel: +49 (0) 1 80-530 85 85
English Tel: +49 (0) 1 80-532 78 32
Français Tel: +49 (0) 1 80-532 93 58
Italiano Tel: +49 (0) 1 80-534 16 80

National Semiconductor Asia Pacific Customer Response Group
Tel: 65-2544466
Fax: 65-2504466
Email: sea.support@nsc.com

National Semiconductor Japan Ltd.
Tel: 81-3-5620-6175
Fax: 81-3-5620-6179