

LV5122T



ON Semiconductor®

www.onsemi.com

CMOS IC

2-Cell Lithium-Ion Secondary Battery Protection IC

Overview

The LV5122T is a protection IC for 2-cell lithium-ion secondary batteries.

Feature

- Monitoring function for each cell: Detects overcharge and over-discharge conditions and controls the charging and discharging operation of each cell.
- High detection voltage accuracy: Over-charge detection accuracy $\pm 25\text{mV}$
Over-discharge detection accuracy $\pm 100\text{mV}$
- Hysteresis cancel function: The hysteresis of over-discharge detection voltage is canceled by sensing the connection of a load after overcharging has been detected.
- Discharge current monitoring function: Detects over-currents and load shorting, and an excessive discharge current is controlled.
- Low current consumption: Normal operation mode typ. $6.0\mu\text{A}$
Stand by mode max. $0.2\mu\text{A}$
- 0V cell charging function: Charging is enabled even when the cell voltage is 0V by giving a potential difference between the V_{DD} pin and V^- pin.

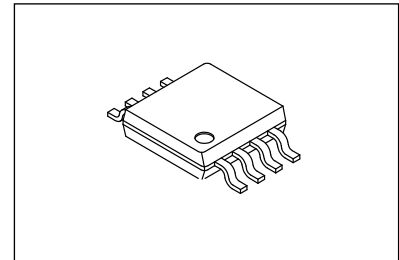

MSOP8 (150mil)

Specifications

Absolute Maximum Ratings at $T_a = 25^\circ\text{C}$

Parameter	Sym bol	Conditions	Ratings	Unit
Power supply voltage	V_{DD}		-0.3 to +12	V
Input voltage Charger minus voltage	V^-		$V_{DD}-28$ to $V_{DD}+0.3$	V
Output voltage	Cout pin voltage	V_{cout}	$V_{DD}-28$ to $V_{DD}+0.3$	V
	Dout pin voltage	V_{dout}	$V_{SS}-0.3$ to $V_{DD}+0.3$	V
Allowable power dissipation	P_{dmax}	Independent IC	170	mW
Operating ambient temperature	T_{opr}		-30 to +80	$^\circ\text{C}$
Storage temperature	T_{stg}		-40 to +125	$^\circ\text{C}$

Stresses exceeding those listed in the Maximum Ratings table may damage the device. If any of these limits are exceeded, device functionality should not be assumed, damage may occur and reliability may be affected.

ORDERING INFORMATION

See detailed ordering and shipping information on page 12 of this data sheet.

LV5122T

Electrical Characteristics 1 at Ta = 25°C, unless especially specified.

Parameter	Symbol	Conditions	Ratings			Unit
			min	typ	max	
Operation input voltage	Vcell	Between V _{DD} and V _{SS}	1.5		10	V
0V cell charging minimum operation voltage	Vmin	Between V _{DD} -V _{SS} =0 and V _{DD} -V ⁻			1.5	V
Over-charge detection voltage	Vd1		4.325	4.350	4.375	V
Over-charge reset voltage	Vh1		4.100	4.150	4.200	V
Over-charge detection delay time	td1	V _{DD} -Vc=3.5V→4.5V, Vc-V _{SS} =3.5V	0.5	1.0	1.5	s
Over-charge reset delay time	tr1	V _{DD} -Vc=4.5V→3.5V, Vc-V _{SS} =3.5V	20.0	40.0	60.0	ms
Over-discharge detection voltage	Vd2		2.20	2.30	2.40	V
Over-discharge reset hysteresis voltage	Vh2		10.0	20.0	40.0	mV
Over-discharge detection delay time	td2	V _{DD} -Vc=3.5V→2.2V, Vc-V _{SS} =3.5V	50	100	150	ms
Over-discharge reset delay time	tr2	V _{DD} -Vc=2.2V→3.5V, Vc-V _{SS} =3.5V	0.5	1.0	1.5	ms
Over-current detection voltage	Vd3	V _{DD} -Vc=3.5V, Vc-V _{SS} =3.5V	0.28	0.30	0.32	V
Over-current reset hysteresis voltage	Vh3	V _{DD} -Vc=3.5V, Vc-V _{SS} =3.5V	5.0	10.0	20.0	mV
Over-current detection delay time	td3	V _{DD} -Vc=3.5V, Vc-V _{SS} =3.5V	2.5	5.0	7.5	ms
Over-current reset delay time	tr3	V _{DD} -Vc=3.5V, Vc-V _{SS} =3.5V	0.5	1.0	1.5	ms
Short circuit detection voltage	Vd4	V _{DD} -Vc=3.5V, Vc-V _{SS} =3.5V	1.0	1.3	1.6	V
Short circuit detection delay time	td4	V _{DD} -Vc=3.5V, Vc-V _{SS} =3.5V	0.2	0.5	0.8	ms
Standby reset voltage	Vstb	Between V _{DD} -Vc=2.0V, Vc-V _{SS} =2.0V (V ⁻)-V _{SS}	V _{DD} ×0.4	V _{DD} ×0.5	V _{DD} ×0.6	V
Reset resistance (connected to V _{DD})	R _{DD}		100	200	400	kΩ
Reset resistance (connected to V _{SS})	R _{SS}		0.5	1.0	1.5	MΩ
Cout Nch ON voltage	V _{OL1}	I _{OL} =50μA, V _{DD} -Vc=4.4V, Vc-V _{SS} =4.4V			0.5	V
Cout Pch ON voltage	V _{OH1}	I _{OL} =50μA, V _{DD} -Vc=3.9V, Vc-V _{SS} =3.9V	V _{DD} -0.5			V
Dout Nch ON voltage	V _{OL2}	I _{OL} =50μA, V _{DD} -Vc=Vd2(min), Vc-V _{SS} =Vd2(min)			0.5	V
Dout Pch ON voltage	V _{OH2}	I _{OL} =50μA, V _{DD} -Vc=3.9V, Vc-V _{SS} =3.9V	V _{DD} -0.5			V
Vc input current	I _{vc}	V _{DD} -Vc=3.5V, Vc-V _{SS} =3.5V		0.0	1.0	μA
Current drain	I _{DD}	V _{DD} -Vc=3.5V, Vc-V _{SS} =3.5V		6.0	13.0	μA
Standby current	I _{stb}	V _{DD} -Vc=2.2V, Vc-V _{SS} =3.5V			0.2	μA

Product parametric performance is indicated in the Electrical Characteristics for the listed test conditions, unless otherwise noted. Product performance may not be indicated by the Electrical Characteristics if operated under different conditions.

LV5122T

Electrical Characteristics 2 at Ta = -20 to 70°C, unless especially specified.

Parameter	Symbol	Conditions	Ratings			Unit
			min	typ	max	
Operation input voltage	Vcell	Between V _{DD} and V _{SS}	1.65		10	V
0V cell charging minimum operation voltage	Vmin	Between V _{DD} -V _{SS} =0 and V _{DD} -V ⁻			1.65	V
Over-charge detection voltage	Vd1		4.305	4.350	4.390	V
Over-charge reset voltage	Vh1		4.080	4.150	4.215	V
Over-charge detection delay time	td1	V _{DD} -Vc=3.5V→4.5V, Vc-V _{SS} =3.5V	0.350	1.000	1.950	s
Over-charge reset delay time	tr1	V _{DD} -Vc=4.5V→3.5V, Vc-V _{SS} =3.5V	14.0	40.0	78.0	ms
Over-discharge detection voltage	Vd2		2.18	2.30	2.42	V
Over-discharge reset hysteresis voltage	Vh2		8.0	20.0	42.0	mV
Over-discharge detection delay time	td2	V _{DD} -Vc=3.5V→2.2V, Vc-V _{SS} =3.5V	35	100	195	ms
Over-discharge reset delay time	tr2	V _{DD} -Vc=2.2V→3.5V, Vc-V _{SS} =3.5V	0.35	1.0	1.95	ms
Over-current detection voltage	Vd3	V _{DD} -Vc=3.5V, Vc-V _{SS} =3.5V	0.271	0.300	0.329	V
Over-current reset hysteresis voltage	Vh3	V _{DD} -Vc=3.5V, Vc-V _{SS} =3.5V	3.5	10.0	23.0	mV
Over-current detection delay time	td3	V _{DD} -Vc=3.5V, Vc-V _{SS} =3.5V	1.75	5.00	9.75	ms
Over-current reset delay time	tr3	V _{DD} -Vc=3.5V, Vc-V _{SS} =3.5V	0.35	1.00	1.95	ms
Short circuit detection voltage	Vd4	V _{DD} -Vc=3.5V, Vc-V _{SS} =3.5V	0.9	1.3	1.7	V
Short circuit detection delay time	td4	V _{DD} -Vc=3.5V, Vc-V _{SS} =3.5V	0.14	0.5	1.04	ms
Standby reset voltage	Vstb	Between V _{DD} -Vc=2.0V, Vc-V _{SS} =2.0V (V ⁻)-V _{SS}	V _{DD} ×0.4	V _{DD} ×0.5	V _{DD} ×0.6	V
Reset resistance (connected to V _{DD})	R _{DD}		70	200	520	kΩ
Reset resistance (connected to V _{SS})	R _{SS}		0.35	1.0	1.95	MΩ
Cout Nch ON voltage	V _{OL1}	I _{OL} =50μA, V _{DD} -Vc=4.4V, Vc-V _{SS} =4.4V			0.5	V
Cout Pch ON voltage	V _{OH1}	I _{OL} =50μA, V _{DD} -Vc=3.9V, Vc-V _{SS} =3.9V	V _{DD} -0.5			V
Dout Nch ON voltage	V _{OL2}	I _{OL} =50μA, V _{DD} -Vc=Vd2(min), Vc-V _{SS} =Vd2(min)			0.5	V
Dout Pch ON voltage	V _{OH2}	I _{OL} =50μA, V _{DD} -Vc=3.9V, Vc-V _{SS} =3.9V	V _{DD} -0.5			V
Vc input current	Ivc	V _{DD} -Vc=3.5V, Vc-V _{SS} =3.5V		0.0	1.0	μA
Current drain	I _{DD}	V _{DD} -Vc=3.5V, Vc-V _{SS} =3.5V		6.0	16.9	μA
Standby current	Istb	V _{DD} -Vc=2.2V, Vc-V _{SS} =3.5V			0.2	μA

The Ratings of the table above is a design guarantees and are not measured.

Product parametric performance is indicated in the Electrical Characteristics for the listed test conditions, unless otherwise noted. Product performance may not be indicated by the Electrical Characteristics if operated under different conditions.

LV5122T

Electrical Characteristics 3 at Ta = -30 to 85°C, unless especially specified.

Parameter	Symbol	Conditions	Ratings			Unit
			min	typ	max	
Operation input voltage	Vcell	Between VDD and VSS	1.73		10	V
0V cell charging minimum operation voltage	Vmin	Between VDD-VSS = 0 and VDD-V ⁻			1.73	V
Over-charge detection voltage	Vd1		4.295	4.350	4.395	V
Over-charge reset voltage	Vh1		4.070	4.150	4.220	V
Over-charge detection delay time	td1	VDD-Vc=3.5V→4.5V, Vc-VSS=3.5V	0.3	1.0	2.1	s
Over-charge reset delay time	tr1	VDD-Vc=4.5V→3.5V, Vc-VSS=3.5V	12.0	40.0	84.0	ms
Over-discharge detection voltage	Vd2		2.17	2.30	2.43	V
Over-discharge reset hysteresis voltage	Vh2		6.0	20.0	42.0	mV
Over-discharge detection delay time	td2	VDD-Vc=3.5V→2.2V, Vc-VSS=3.5V	30	100	210	ms
Over-discharge reset delay time	tr2	VDD-Vc=2.2V→3.5V, Vc-VSS=3.5V	0.3	1.0	2.1	ms
Over-current detection voltage	Vd3	VDD-Vc=3.5V, Vc-VSS=3.5V	0.267	0.300	0.333	V
Over-current reset hysteresis voltage	Vh3	VDD-Vc=3.5V, Vc-VSS=3.5V	2.5	10.0	240	mV
Over-current detection delay time	td3	VDD-Vc=3.5V, Vc-VSS=3.5V	1.5	5.0	10.5	ms
Over-current reset delay time	tr3	VDD-Vc=3.5V, Vc-VSS=3.5V	0.3	1.0	2.1	ms
Short circuit detection voltage	Vd4	VDD-Vc=3.5V, Vc-VSS=3.5V	0.8	1.3	1.8	V
Short circuit detection delay time	td4	VDD-Vc=3.5V, Vc-VSS=3.5V	0.12	0.5	1.12	ms
Standby reset voltage	Vstb	Between VDD-Vc=2.0V, Vc-VSS=2.0V (V ⁻)-VSS	VDD×0.4	VDD×0.5	VDD×0.6	V
Reset resistance (connected to VDD)	RDD		60	200	560	kΩ
Reset resistance (connected to VSS)	RSS		0.3	1.0	2.1	MΩ
Cout Nch ON voltage	VO L1	IOL=50μA, VDD-Vc=4.4V, Vc-VSS=4.4V			0.5	V
Cout Pch ON voltage	VO H1	IOL=50μA, VDD-Vc=3.9V, Vc-VSS=3.9V	VDD-0.5			V
Dout Nch ON voltage	VO L2	IOL=50μA, VDD-Vc=Vd2(min), Vc-VSS=Vd2(min)			0.5	V
Dout Pch ON voltage	VO H2	IOL=50μA, VDD-Vc=3.9V, Vc-VSS=3.9V	VDD-0.5			V
Vc input current	Ivc	VDD-Vc=3.5V, Vc-VSS=3.5V		0.0	1.0	μA
Current drain	IDD	VDD-Vc=3.5V, Vc-VSS=3.5V		6.0	18.2	μA
Standby current	Istb	VDD-Vc=2.2V, Vc-VSS=3.5V			0.2	μA

The Ratings of the table above is a design guarantees and are not measured.

Product parametric performance is indicated in the Electrical Characteristics for the listed test conditions, unless otherwise noted. Product performance may not be indicated by the Electrical Characteristics if operated under different conditions.

LV5122T

Package Dimensions

unit : mm

Micro8 / MSOP8 (150 mil)

CASE 846AH

ISSUE A

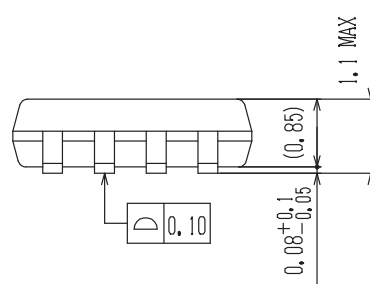
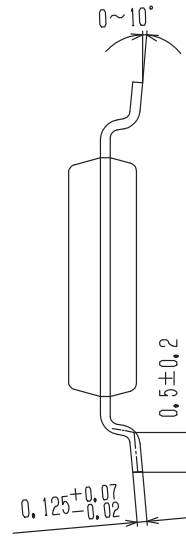
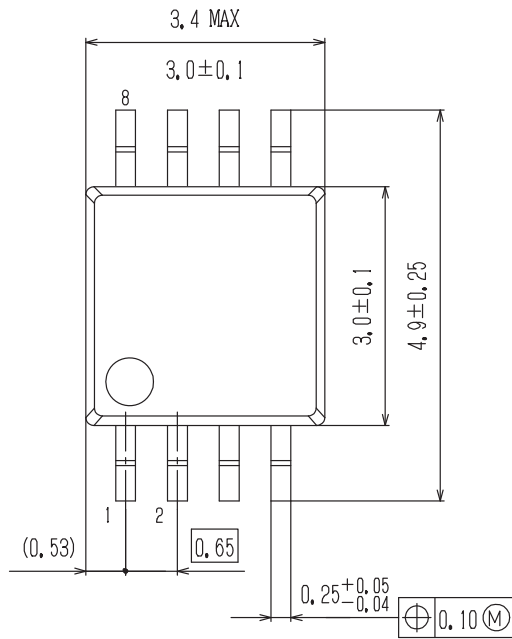

SOLDERING FOOTPRINT*

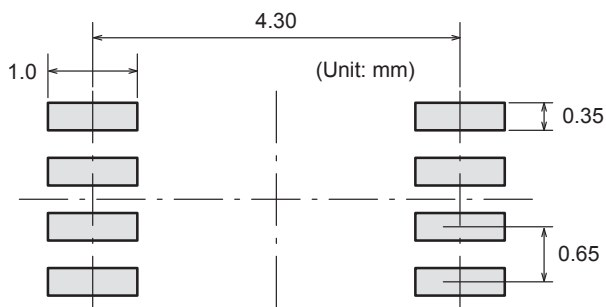

GENERIC MARKING DIAGRAM*

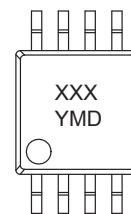

XXX = Specific Device Code
 Y = Year
 M = Month
 D = Additional Traceability Data

NOTE: The measurements are not to guarantee but for reference only.

*For additional information on our Pb-Free strategy and soldering details, please download the ON Semiconductor Soldering and Mounting Techniques Reference Manual, SOLDERRM/D.

*This information is generic. Please refer to device data sheet for actual part marking. Pb-Free indicator, "G" or microdot "•", may or may not be present.

LV5122T

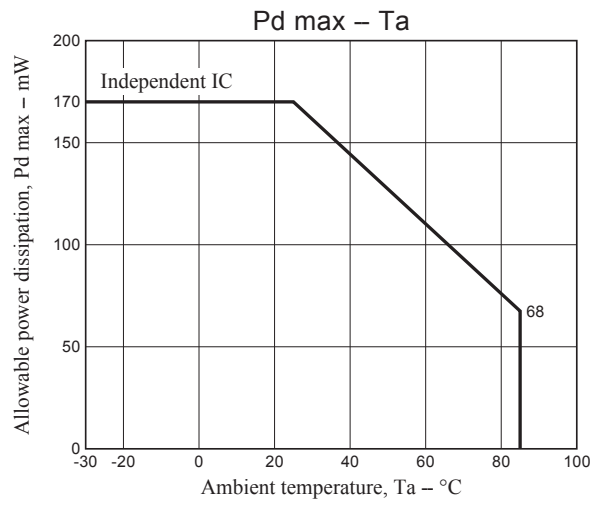

Pin Assignment

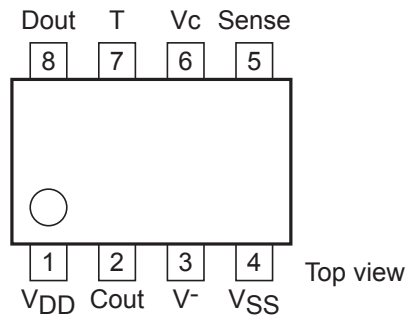

Pin Functions

Pin No.	Symbol	Description
1	V _{DD}	V _{DD} pin
2	Cout	Overcharge detection output pin
3	V ⁻	Charger minus voltage input pin
4	V _{SS}	V _{SS} pin
5	Sense	Sense pin
6	V _c	Intermediate voltage input pin
7	T	Pin to shorten detection time (open under normal condition)
8	Dout	Overdischarge detection output pin

LV5122T

Block Diagram

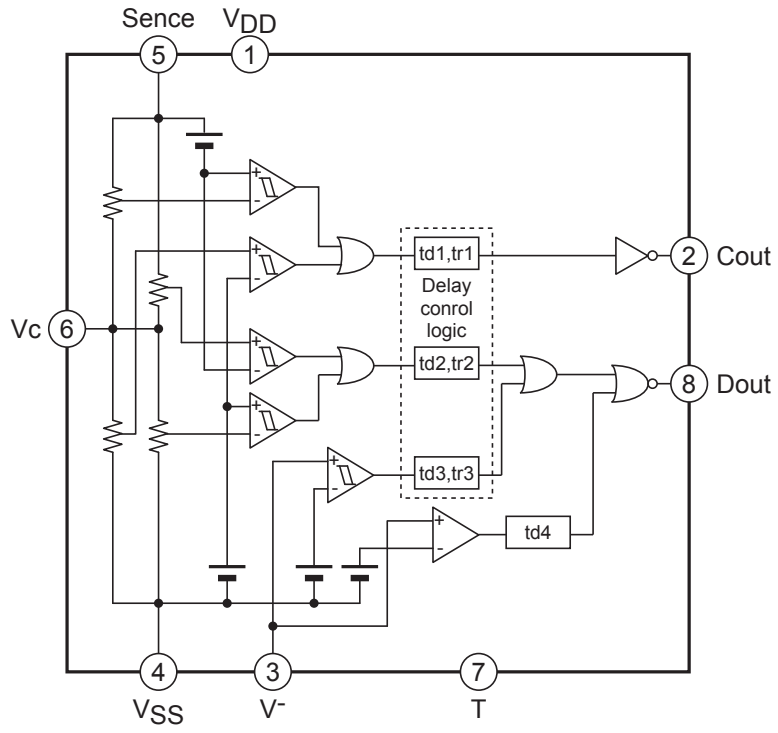

Functional Description

Over-charge detection

If either of the cell voltage is equal to or more than the over-charge detection voltage, stop further charging by turning “L” the Cout pin and turning off external Nch MOS FET after the over-charge detection delay time. This delay time is set by the internal counter.

The over-charge detection comparator has the hysteresis function. Note that this hysteresis can be cancelled by connecting the load after detection of over-charge detection.

Once over-charge detection is made, over-current detection is not made to prevent malfunction. Note that short-circuit can be detected.

Over-charge return

If charger is connected and both cell voltages become equal to or lower than the over-charge recovery voltage or over-charge detection voltage when load is connected, the Cout pin returns to “H” after the over-charge recovery delay time set by the internal counter.

When load is connected and either cell or both cell voltages are equal to or more than the over-charge detection voltage, the Cout pin does not return to “H.” When the load current is passed through the external Cout pin parasite diode of Nch MOS FET after the over-charge recovery delay time and each cell voltage becomes equal to or below over-charge detection voltage, the Cout returns to “H.”

Over-discharge detection

When either cell voltage is equal to or below over-discharge voltage, stop further discharge by turning “L” the Dout pin and turning off external Nch MOS FET after the over-charge detection delay time.

The IC becomes standby state after detecting over-discharge and its consumption current is kept at about 0A. After detection, the V⁻ pin will be connected to V_{DD} pin via 200kΩ.

Over-discharge return

Return from over-discharge is made by connecting charger. If the V⁻ pin voltage becomes equal to or lower than the standby return voltage by connecting charger after detecting over-discharge, it returns from the standby state to start cell voltage monitoring. If both voltages become equal to or more than the over-discharge detection voltage by charging, the Dout pin returns to “H” after the over-discharge return.

Over-current detection

When high current is passed through the battery, the V potential rises by the ON resistor of external MOS FET and becomes equal to or more than the over-current detection voltage, that will be deemed over-current state. Turn “L” the Dout pin after the over-current detection delay time and turn off the external Nch MOS FET to prevent high current in the circuit. The delay time is set by the internal counter. After detection, the V⁻ pin will be connected to V_{SS} via 1MΩ. It will not go into standby state after detecting over-current.

Short circuit detection

If greater discharge current is passed and the V⁻ pin voltage becomes equal to or more than the short-circuit detection voltage, it will go into short-circuit detection state after the short circuit delay time shorter than the over-current detection delay time. When short-circuit is detected, just like the time of over-current detection, turn Dout pin “L” and turn off external Nch MOS FET to prevent high current in the circuit. The V⁻ pin will be connected to V_{SS} after detection via 30kΩ. It will not go into standby state after detecting short-circuit.

Over-current/short-detection return

After detecting over-current or short circuit, the return resistor (typ. 1MΩ) between V⁻ pin and V_{SS} pin becomes effective and if the resistor is opened the V⁻ pin voltage will be pulled by the V_{SS} pin voltage. Thereafter, the IC will return from the over-current/short-circuit detection state when the V⁻ pin voltage becomes equal to or below the over-current detection voltage and the Dout pin returns to “H” after over-current return delay time set by the internal counter.

0V cell charge

If the cell voltage is 0V but a potential difference between V_{DD} and V becomes equal to or greater than the 0V cell charging lowest operation voltage, the Cout pin will output “H” and enable charging.

LV5122T

Test time reduction function

By turning T pin to the V_{DD} potential, the delay times set by the counter can be cut. Normal time settings if T pin is open. Delay time not set by the counter cannot be controlled by this pin.

Operation in case of detection overlap

Overlap state		Operation in case of detection overlap	State after detection
When, during over-charge detection,	Over-discharge detection is made,	Over-charge detection is preferred. If over-discharge state continues even after over-charge detection, over-discharge detection is resumed.	When over-charge detection is made first, V^- is released. When over-discharge is detected after over-charge detection, the standby state is not effectuated. Note that V^- is connected to V_{DD} via 200k Ω .
	Over-current detection is made,	(*1) Both detections' can be made in parallel. Over-charge detection continues even when the over-current state occurs. If the over-charge state occurs first, over-current detection is interrupted.	(*2) When over-current is detected first, V^- is connected to V_{SS} via 1M Ω . When over-charge detection is made first, V^- is released.
When, during over-discharge detection,	Over-charge detection is made,	Over-discharge detection is interrupted and over-charge detection is preferred. When over-discharge state continues even after over-charge detection, over-discharge detection is resumed.	The standby state is not effectuated when over-discharge detection is made after over-charge detection. Note that V^- is connected to V_{DD} via 200k Ω .
	Over-current detection is made,	(*3) Both detections can be made in parallel. Over-discharge detection continues even when the over-current state is effectuated first. Over-current detection is interrupted when the over-discharge state is effectuated first,	(*4) If over-current is detected in advance, V^- will be connected to V_{SS} via 1M Ω . After detecting over-discharge, V^- will be connected to V_{DD} via 200k Ω to get into standby state. If over-discharge is detected in advance, V^- will be connected to V_{DD} via 200k Ω to get into standby state.
When, during over-current detection,	Over-charge detection is made,	(*1)	(*2)
	Over-discharge detection is made,	(*3)	(*4)

(Note) Short-circuit detection can be made independently.

LV5122T

Timing Chart [Cout Output System]

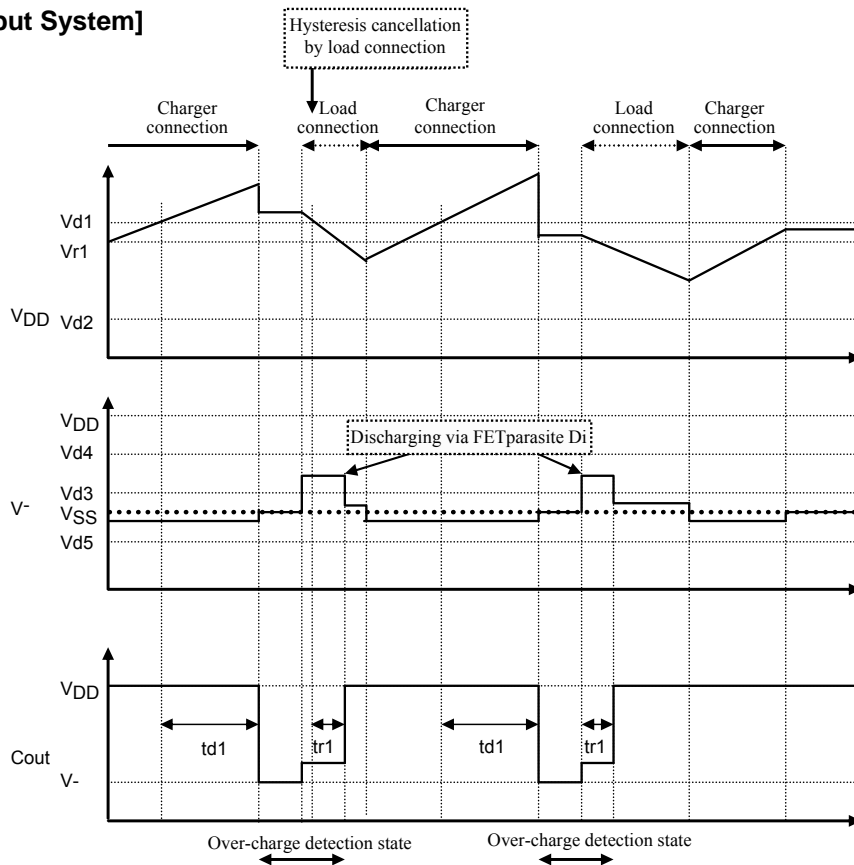

[Dout Output System]

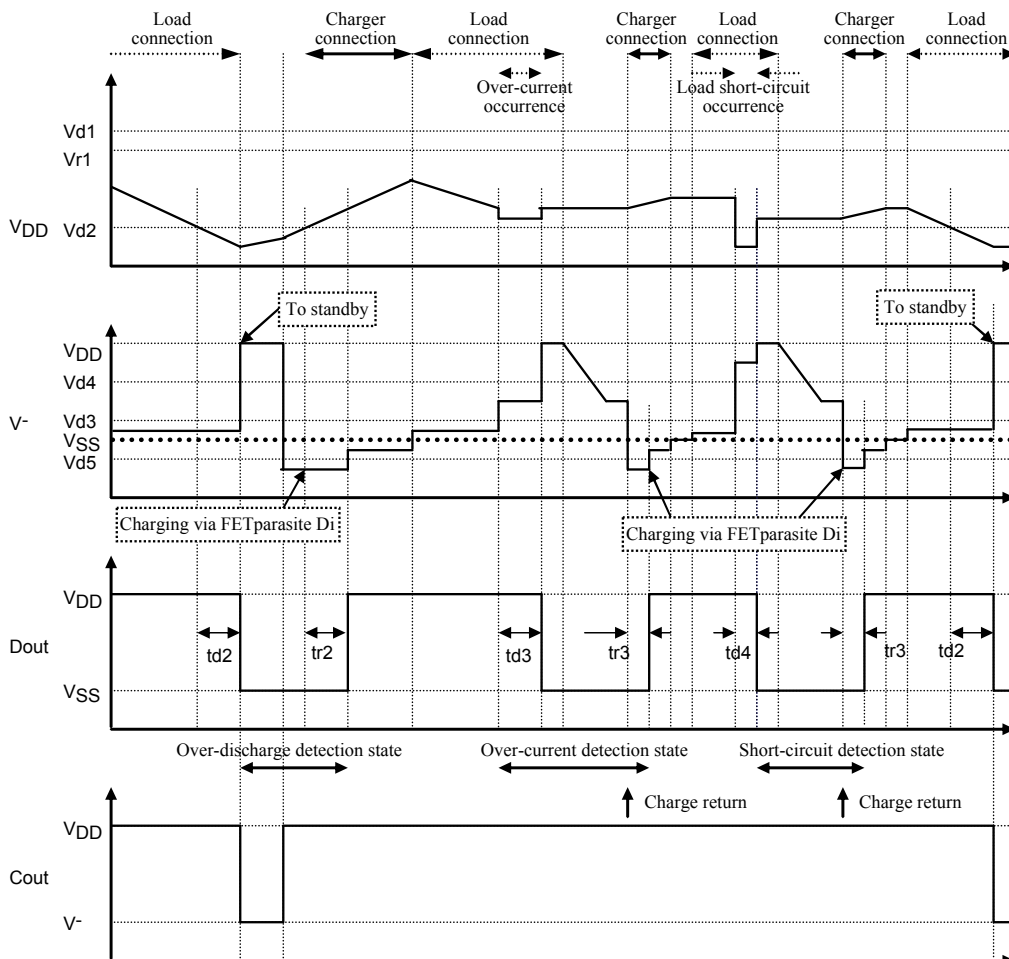

LV5122T

Application Circuit Example

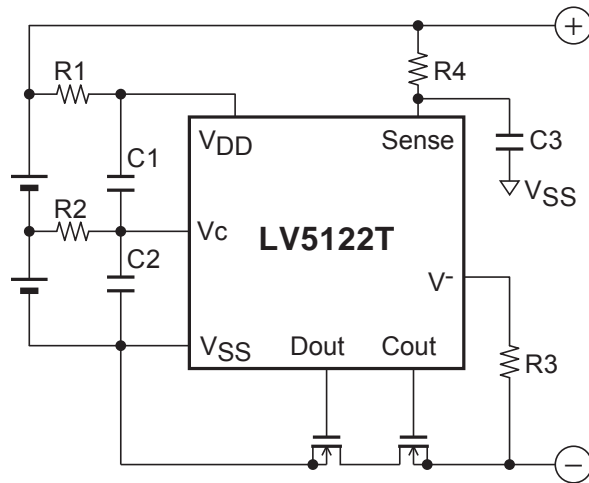

Components	Recommended value	max	unit
R1, R2	100	1k	Ω
R3	2k	4k	Ω
R4	100	10k	Ω
C1, C2, C3	0.1 μ	1 μ	F

* These numbers don't mean to guarantee the characteristic of the IC.

* In addition to the components in the upper diagram, it is necessary to insert a capacitor with enough capacity between VDD and VSS of the IC as near as possible to stabilize the power supply voltage to the IC.

ORDERING INFORMATION

Device	Package	Shipping (Qty / Packing)
LV5122T-TLM-E	MSOP8 (150mil) (Pb-Free)	2000 / Tape & Reel

† For information on tape and reel specifications, including part orientation and tape sizes, please refer to our Tape and Reel Packaging Specifications Brochure, BRD8011/D. http://www.onsemi.com/pub_link/Collateral/BRD8011-D.PDF

ON Semiconductor and the ON logo are registered trademarks of Semiconductor Components Industries, LLC (SCILLC) or its subsidiaries in the United States and/or other countries. SCILLC owns the rights to a number of patents, trademarks, copyrights, trade secrets, and other intellectual property. A listing of SCILLC's product/patent coverage may be accessed at www.onsemi.com/site/pdf/Patent-Marking.pdf. SCILLC reserves the right to make changes without further notice to any products herein. SCILLC makes no warranty, representation or guarantee regarding the suitability of its products for any particular purpose, nor does SCILLC assume any liability arising out of the application or use of any product or circuit, and specifically disclaims any and all liability, including without limitation special, consequential or incidental damages. "Typical" parameters which may be provided in SCILLC data sheets and/or specifications can and do vary in different applications and actual performance may vary over time. All operating parameters, including "Typicals" must be validated for each customer application by customer's technical experts. SCILLC does not convey any license under its patent rights nor the rights of others. SCILLC products are not designed, intended, or authorized for use as components in systems intended for surgical implant into the body, or other applications intended to support or sustain life, or for any other application in which the failure of the SCILLC product could create a situation where personal injury or death may occur. Should Buyer purchase or use SCILLC products for any such unintended or unauthorized application, Buyer shall indemnify and hold SCILLC and its officers, employees, subsidiaries, affiliates, and distributors harmless against all claims, costs, damages, and expenses, and reasonable attorney fees arising out of, directly or indirectly, any claim of personal injury or death associated with such unintended or unauthorized use, even if such claim alleges that SCILLC was negligent regarding the design or manufacture of the part. SCILLC is an Equal Opportunity/Affirmative Action Employer. This literature is subject to all applicable copyright laws and is not for resale in any manner.