

480MHz, 1 x 1 Video Crosspoint Switch with Tally Output

November 1996

Features

- Low Power Dissipation 105mW
- Symmetrical Slew Rates 1700V/ μ s
- 0.1dB Gain Flatness..... 250MHz
- Off Isolation (100MHz)..... 85dB
- Differential Gain..... 0.01%
- Differential Phase..... 0.01 Degrees
- High ESD Rating >2000V
- TTL Compatible Enable Input
- Open Collector Tally Output
- Improved Replacement for GX4201

Applications

- Professional Video Switching and Routing
- Video Multiplexers
- HDTV
- Computer Graphics
- RF Switching and Routing
- PCM Data Routing

Description

The HA4201 is a very wide bandwidth 1 x 1 crosspoint switch ideal for professional video switching, HDTV, computer monitor routing, and other high performance applications. The circuit features very low power dissipation (105mW Enabled, 1mW Disabled), excellent differential gain and phase, and very high off isolation. When disabled, the output is switched to a high impedance state, making the HA4201 ideal for routing matrix equipment.

The HA4201 requires no external current source, and features fast switching and symmetric slew rates. The tally output is an open collector PNP transistor to V_{CC} , and is activated whenever EN = 1 to provide an indication of crosspoint selection.

For applications which don't require a Tally output, please refer to the HA4600 data sheet.

Ordering Information

PART NUMBER (BRAND)	TEMP. RANGE (°C)	PACKAGE	PKG. NO.
HA4201CP	0 to 70	8 Ld PDIP	E8.3
HA4201CB (4201CB)	0 to 70	8 Ld SOIC	M8.15

Pinout

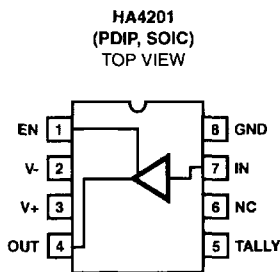

Truth Table

EN	OUT	TALLY
0	High Z	Off
1	Active	On

6
VIDEO CROSS-POINT SWITCHES

HA4201

Absolute Maximum Ratings

Voltage Between V+ and V-	12V
Input Voltage	V _{SUPPLY}
Digital Input Current (Note 2)	±25mA
Output Current	20mA

Operating Conditions

Temperature Range	0°C to 70°C
-------------------------	-------------

Thermal Information

Thermal Resistance (Typical, Note 1)	θ_{JA} (°C/W)
PDIP Package	130
SOIC Package	170
Maximum Junction Temperature (Die)	175°C
Maximum Junction Temperature (Plastic Package)	150°C
Maximum Storage Temperature Range	-65°C to 150°C
Maximum Lead Temperature (Soldering 10s)	300°C (SOIC - Lead Tips Only)

CAUTION: Stresses above those listed in "Absolute Maximum Ratings" may cause permanent damage to the device. This is a stress only rating and operation of the device at these or any other conditions above those indicated in the operational sections of this specification is not implied.

NOTES:

1. θ_{JA} is measured with the component mounted on an evaluation PC board in free air.
2. If an input signal is applied before the supplies are powered up, the input current must be limited to this maximum value.

Electrical Specifications V_{SUPPLY} = ±5V, R_L = 10k Ω , V_{EN} = 2.0V, Unless Otherwise Specified

PARAMETER	TEST CONDITIONS	TEMP. (°C)	MIN	TYP	MAX	UNITS
DC SUPPLY CHARACTERISTICS						
Supply Voltage		Full	±4.5	±5.0	±5.5	V
Supply Current (V _{OUT} = 0V)	V _{EN} = 2.0V	25, 70	-	10.5	13	mA
	V _{EN} = 2.0V	0	-	-	14.5	mA
	V _{EN} = 0.8V	25, 70	-	100	115	μ A
	V _{EN} = 0.8V	0	-	100	125	μ A
ANALOG DC CHARACTERISTICS						
Output Voltage Swing without Clipping	V _{OUT} = V _{IN} ± V _{IO} ± 20mV	25, 70	±2.7	±2.8	-	V
		0	±2.4	±2.5	-	V
Output Current		Full	15	20	-	mA
Input Bias Current		Full	-	30	50	μ A
Output Offset Voltage		25	-10	-	10	mV
Output Offset Voltage Drift (Note 3)		Full	-	25	50	μ V/°C
SWITCHING CHARACTERISTICS						
Turn-On Time		25	-	160	-	ns
Turn-Off Time		25	-	320	-	ns
DIGITAL DC CHARACTERISTICS						
Input Logic High Voltage		Full	2	-	-	V
Input Logic Low Voltage		Full	-	-	0.8	V
EN Input Current	V _{EN} = 0 to 4V	Full	-2	-	2	μ A
Tally Output High Voltage	I _{OH} = 1mA	Full	4.7	4.8	-	V
Tally Off Leakage Current	V _{TALLY} = 0V, -5V	Full	-20	-	20	μ A
AC CHARACTERISTICS						
Insertion Loss	1V _{p-p}	Full	-	0.04	0.05	dB
-3dB Bandwidth	R _S = 82 Ω , C _L = 10pF		-	480	-	MHz
	R _S = 43 Ω , C _L = 15pF	25	-	380	-	MHz
	R _S = 36 Ω , C _L = 21pF	25	-	370	-	MHz

HA4201

Electrical Specifications $V_{SUPPLY} = \pm 5V$, $R_L = 10k\Omega$, $V_{EN} = 2.0V$, Unless Otherwise Specified (Continued)

PARAMETER	TEST CONDITIONS	TEMP. (°C)	MIN	TYP	MAX	UNITS
±0.1dB Flat Bandwidth	$R_S = 82\Omega$, $C_L = 10pF$	25	-	250	-	MHz
	$R_S = 43\Omega$, $C_L = 15pF$	25	-	175	-	MHz
	$R_S = 36\Omega$, $C_L = 21pF$	25	-	170	-	MHz
Input Resistance		Full	200	400	-	k Ω
Input Capacitance		Full	-	1.0	-	pF
Enabled Output Resistance		Full	-	15	-	Ω
Disabled Output Capacitance	$V_{EN} = 0.8V$	Full	-	2.0	-	pF
Differential Gain	4.43MHz, Note 3	25	-	0.01	0.02	%
Differential Phase	4.43MHz, Note 3	25	-	0.01	0.02	Degrees
Off Isolation	1V _{P-P} , 100MHz, $V_{EN} = 0.8V$, $R_L = 10\Omega$	Full	-	85	-	dB
Slew Rate (1.5V _{P-P} , +SR/-SR)	$R_S = 82\Omega$, $C_L = 10pF$	25	-	1750/1770	-	V/ μ s
	$R_S = 43\Omega$, $C_L = 15pF$	25	-	1460/1360	-	V/ μ s
	$R_S = 36\Omega$, $C_L = 21pF$	25	-	1410/1360	-	V/ μ s
Total Harmonic Distortion (Note 3)		Full	-	0.01	0.1	%
Disabled Output Resistance		Full	-	12	-	M Ω

NOTE:

3. This parameter is not tested. The limits are guaranteed based on lab characterization, and reflect lot-to-lot variation.

AC Test Circuit

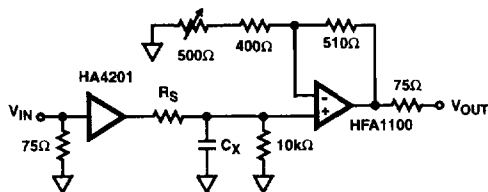

NOTE: $C_L = C_X + \text{Test Fixture Capacitance}$.

PC Board Layout

The frequency response of this circuit depends greatly on the care taken in designing the PC board. **The use of low inductance components such as chip resistors and chip capacitors is strongly recommended, while a solid ground plane is a must!**

Attention should be given to decoupling the power supplies. A large value (10 μ F) tantalum in parallel with a small value (0.1 μ F) chip capacitor works well in most cases.

Keep input and output traces as short as possible, because trace inductance and capacitance can easily become the performance limiting items.

Application Information

General

The HA4201 is a 1 x 1 crosspoint switch that is ideal for the matrix element in small, high input-to-output isolation switches and routers. It also excels as an input buffer for routers with a large number of outputs (i.e. each input must connect to a large number of outputs) and delivers performance superior to most video amplifiers at a fraction of the cost. As an input buffer, the HA4201's low input capacitance and high input resistance provide excellent video terminations when used with an external 75 Ω resistor. This crosspoint contains no feedback or gain setting resistors, so the output is a true high impedance load when the IC is disabled ($EN = 0$).

Frequency Response

Most applications utilizing the HA4201 require a series output resistor, R_S , to tune the response for the specific load capacitance, C_L , driven. Bandwidth and slew rate degrade as C_L increases (as shown in the Electrical Specification table), so give careful consideration to component placement to minimize trace length. As an example, -3dB bandwidth decreases to 160MHz for $C_L = 100pF$, $R_S = 0\Omega$. In big matrix configurations where C_L is large, better frequency response is obtained by cascading two levels of crosspoints in the case of multiplexed outputs (see Figure 2), or distributing the load between two drivers if C_L is due to bussing and subsequent stage input capacitance.

6

VIDEO CROSS-
POINT SWITCHES

Control Signals

EN - The ENABLE input is a TTL/CMOS compatible, active high input. When driven low this input forces the output to a true high impedance state and reduces the power dissipation by two orders of magnitude. The EN input has no on-chip pull-up resistor, so it must be connected to a logic high (recommend V+) if the enable function isn't utilized.

Tally - The Tally output is an open collector PNP transistor connected to V+. When EN = 1, the PNP transistor is enabled and current is delivered to the load. When the crosspoint is disabled, the Tally output presents a very high impedance to the external circuitry. Several Tally outputs may be wire OR'd together to generate complex control signals, as shown with the HA4404 in the application circuits below. The Tally load may be terminated to GND or to V- as long as the continuous output current doesn't exceed 3mA (6mA at 50% duty cycle, etc.).

Switcher/Router Applications

Figure 1 illustrates one possible implementation of a wideband, low power, 4 x 4 switcher/router. A 4 x 4 switcher/router allows any of the four outputs to be driven by any one of the four inputs (e.g. each of the four inputs may connect to a different output, or an input may connect to multiple outputs). This application utilizes the HA4201 for the input buffer, the HA4404 (4 x 1 crosspoint switch) as the switch matrix, and the HFA1112 (programmable gain buffer)

as the gain of two output driver. Figure 2 details a 16 x 1 switcher (basically a 16:1 mux) which uses the HA4201 in a cascaded stage configuration to minimize capacitive loading at each output node, thus increasing system bandwidth.

Power Up Considerations

No signals should be applied to the analog or digital inputs before the power supplies are activated. Latch-up may occur if the inputs are driven at the time of power up. To prevent latch-up, the input currents during power up must not exceed the values listed in the Absolute Maximum Ratings.

Harris' Crosspoint Family

Harris offers a variety of 1 x 1 and 4 x 1 crosspoint switches. In addition to the HA4201, the 1 x 1 family includes the HA4600 which is an essentially similar device but without the Tally output. The 4 x 1 family is comprised of the HA4314, HA4404, and HA4344. The HA4314 is a 14 lead basic 4 x 1 crosspoint. The HA4404 is a 16 lead device with Tally outputs to indicate the selected channel. The HA4344 is a 16 lead crosspoint with synchronized control lines (A0, A1, CS). With synchronization, the control information for the next channel switch can be loaded into the crosspoint without affecting the current state. On a subsequent clock edge the stored control state effects the desired channel switch.

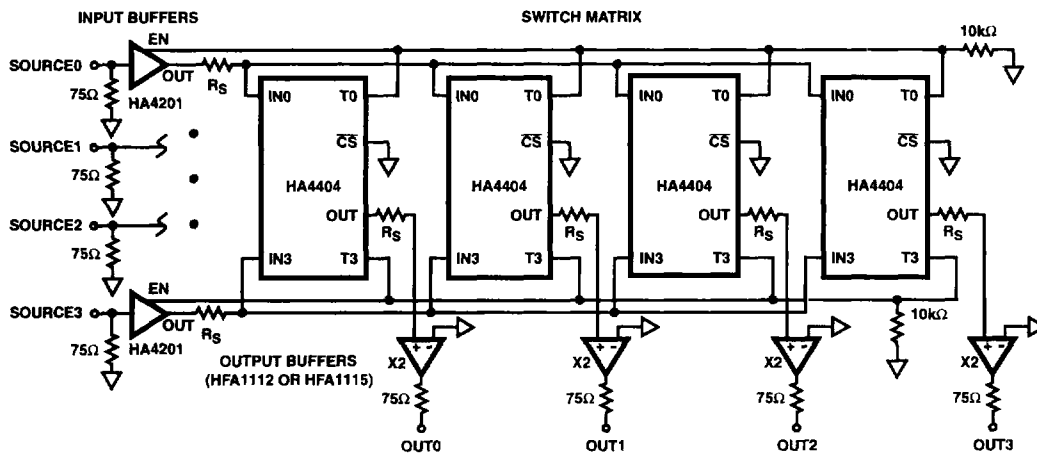

FIGURE 1. 4 x 4 SWITCHER/ROUTER APPLICATION

HA4201

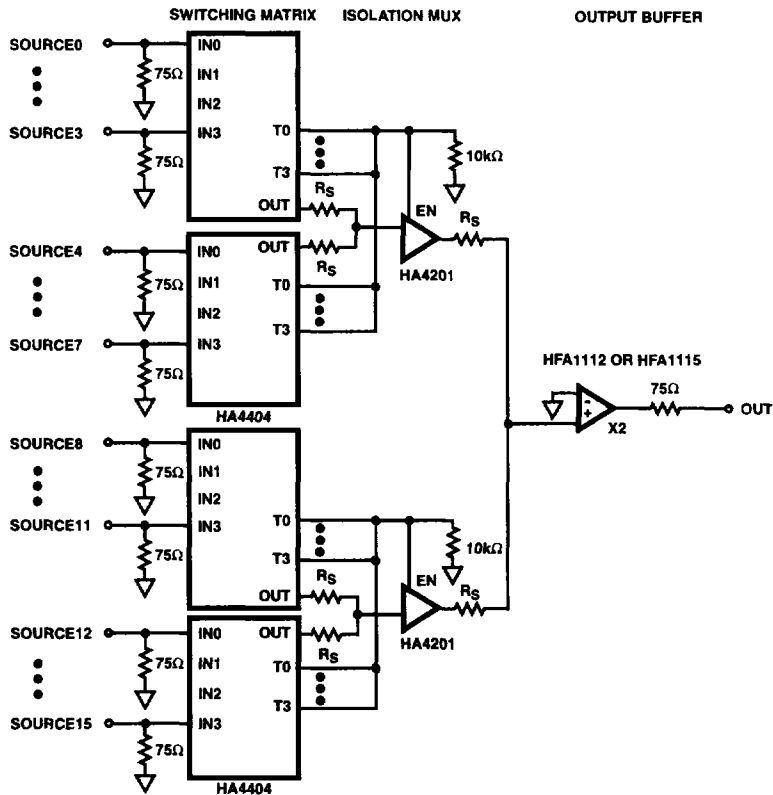

FIGURE 2. 16 x 1 SWITCHER APPLICATION

Typical Performance Curves $V_{SUPPLY} = \pm 5V$, $T_A = 25^\circ C$, $R_L = 10k\Omega$, Unless Otherwise Specified

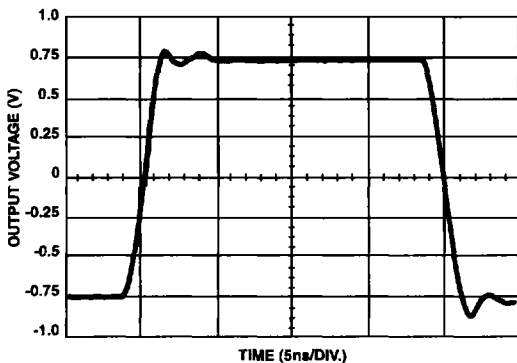

FIGURE 3. LARGE SIGNAL PULSE RESPONSE

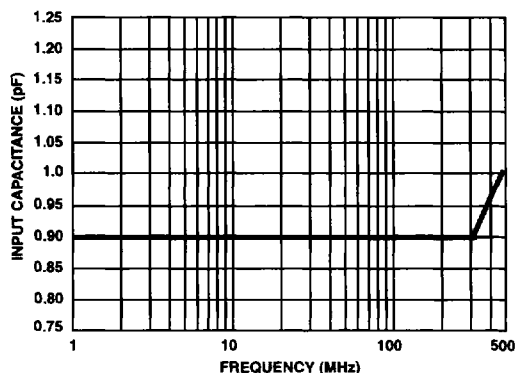

FIGURE 4. INPUT CAPACITANCE vs FREQUENCY

Typical Performance Curves $V_{SUPPLY} = \pm 5V$, $T_A = 25^\circ C$, $R_L = 10k\Omega$, Unless Otherwise Specified (Continued)

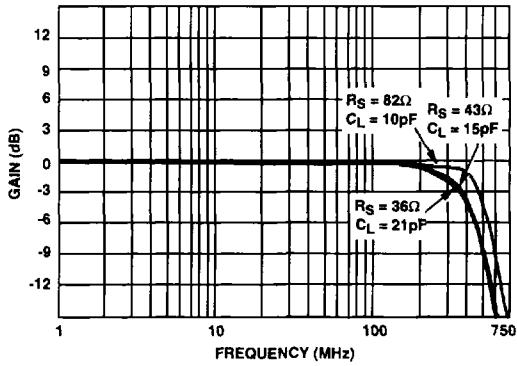

FIGURE 5. FREQUENCY RESPONSE

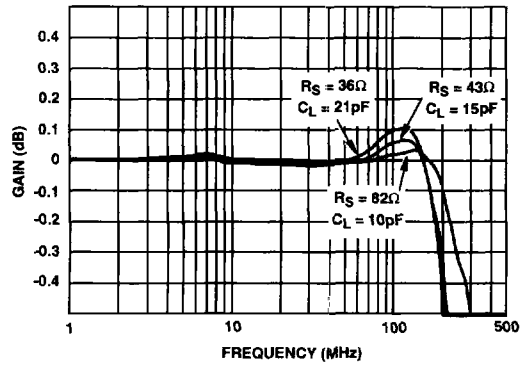

FIGURE 6. GAIN FLATNESS

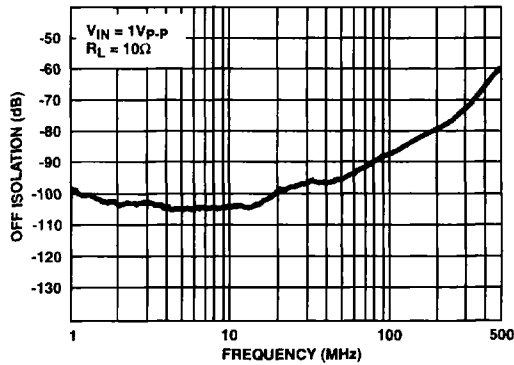

FIGURE 7. OFF ISOLATION

HA4201

Die Characteristics

DIE DIMENSIONS:

51 mils x 36 mils x 19 mils
1290 μ m x 910 μ m x 483 μ m

METALLIZATION:

Type: Metal 1: AlCu (1%)/TiW
Thickness: Metal 1: 6k Å \pm 0.8k Å
Type: Metal 2: AlCu (1%)
Thickness: Metal 2: 16k Å \pm 1.1k Å

PASSIVATION:

Type: Nitride
Thickness: 4k Å \pm 0.5k Å

TRANSISTOR COUNT:

53

SUBSTRATE POTENTIAL (Powered Up):

V-

Metallization Mask Layout

HA4201

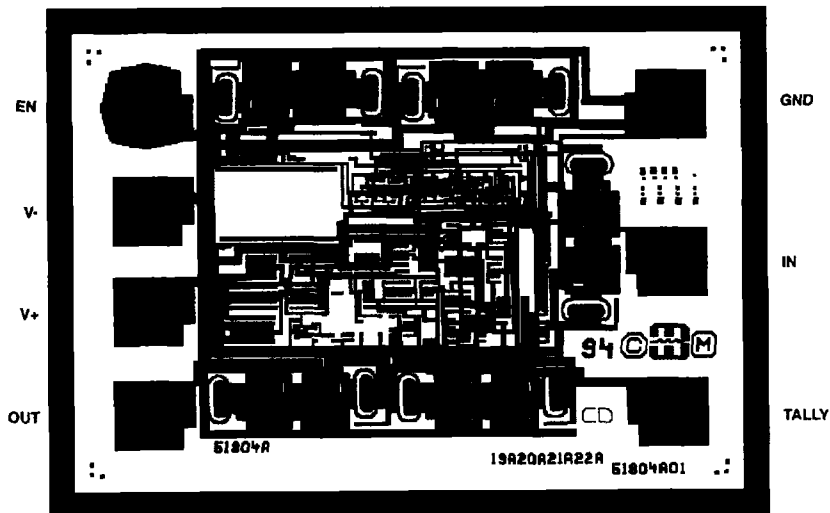

6

VIDEO CROSS-POINT SWITCHES