

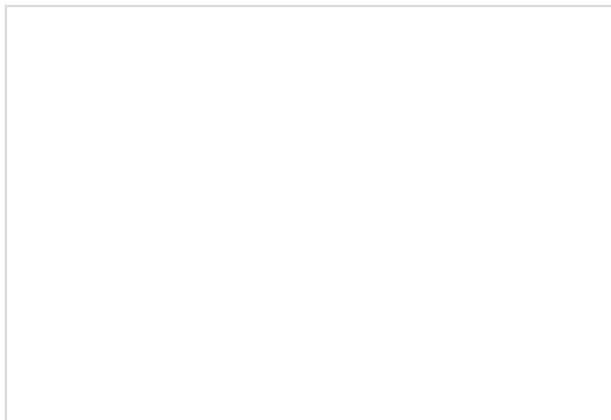

Pushing Performance  
Since 1945

## Carrier\_BT494030\_SOT23-6\_h



Part number	78 01 030 0003
Specification	Carrier_BT494030_SOT23-6_h
HARTING eCatalogue	<a href="https://b2b.harting.com/78010300003">https://b2b.harting.com/78010300003</a>

### Identification

Category	Surface Mount Device
Series	3D-MID
Element	Carrier for electronic components
Specification	Interconnection
Features	Other materials or trace layouts on request!

### Version

Fixing	PCB assembly (SMD)
Pack contents	Tape & reel 3400 pieces on reel Lower quantities available on request!

### Technical characteristics

Operating temperature	-40 ... +125 °C
Storage temperature	-40 ... +125 °C

### Material properties

Material	Liquid crystal polymer (LCP)
Surface (contacts)	Au ( $\geq 0.05 \mu\text{m}$ ) over Ni ( $\geq 4 \mu\text{m}$ ) over Cu (5...11 $\mu\text{m}$ )
Length	4.9 mm
Width	4 mm
Height	3 mm

### Commercial data

Packaging size	1,700
----------------	-------

## Commercial data

Country of origin	Switzerland
European customs tariff number	85340019
GTIN	5713140277403
eCl@ss	27469090 PCB connection technology (other, unspecified)

Other materials or trace layouts on request!



Drawing (dimensions in mm)

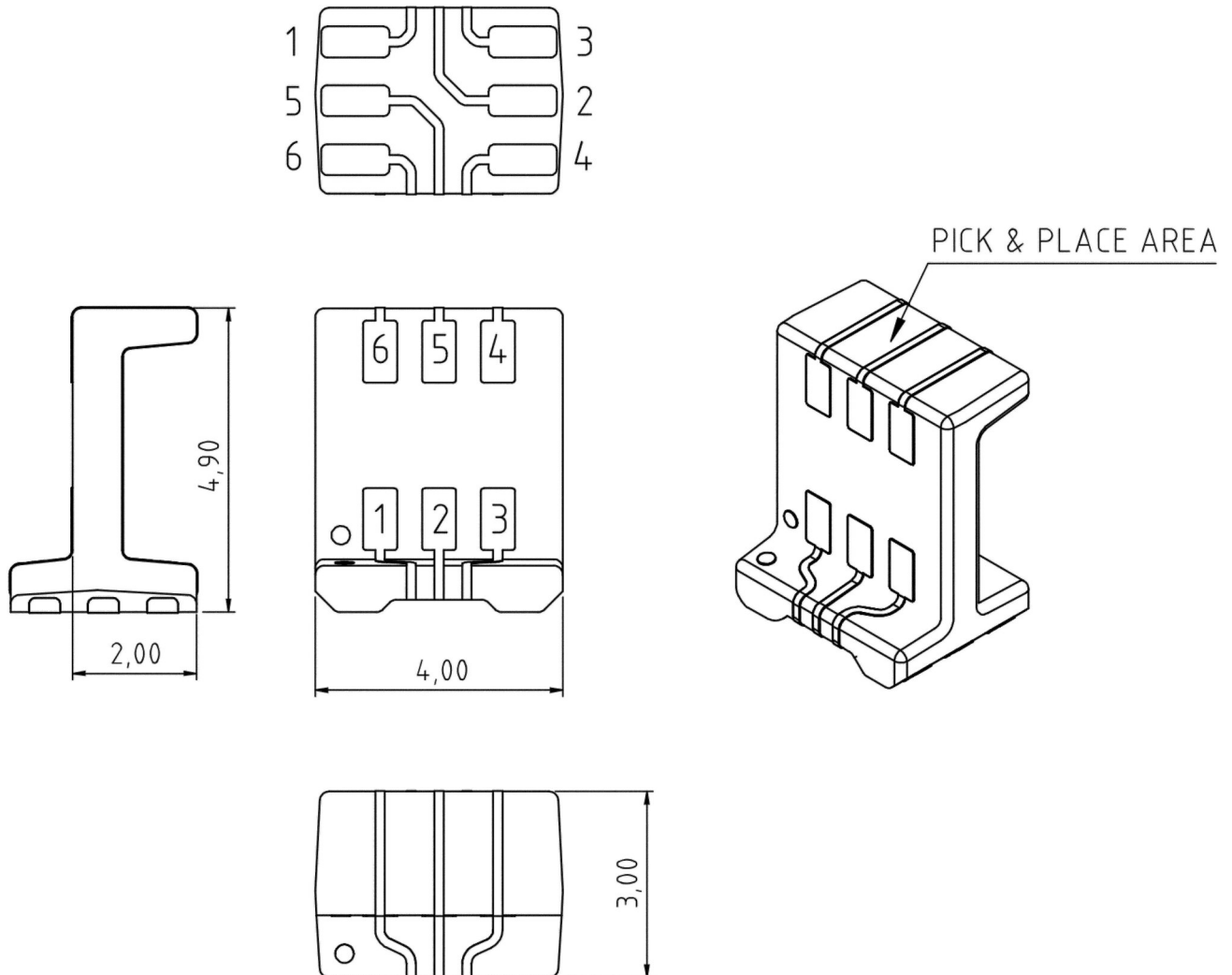

Drawing (dimensions in mm)

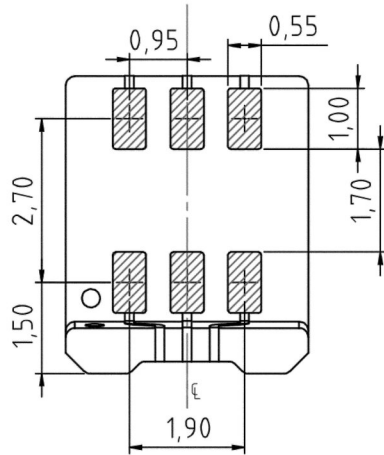

COMPONENT PADS LAYOUT  
 SOIT-23-6

SOLDERING PADS

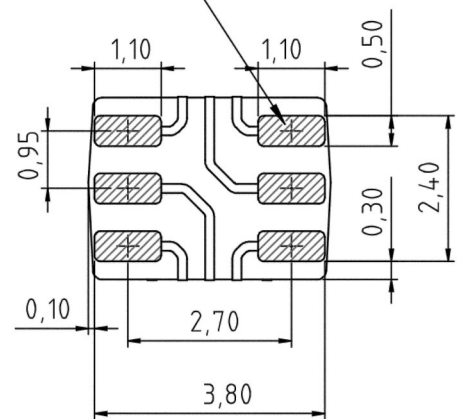

CARRIER PATTERN LAYOUT

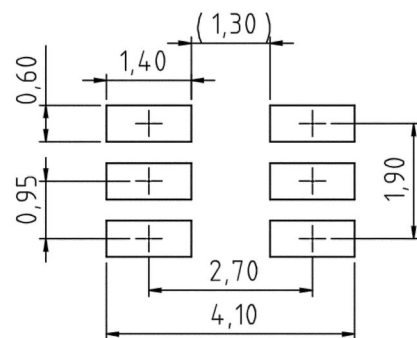
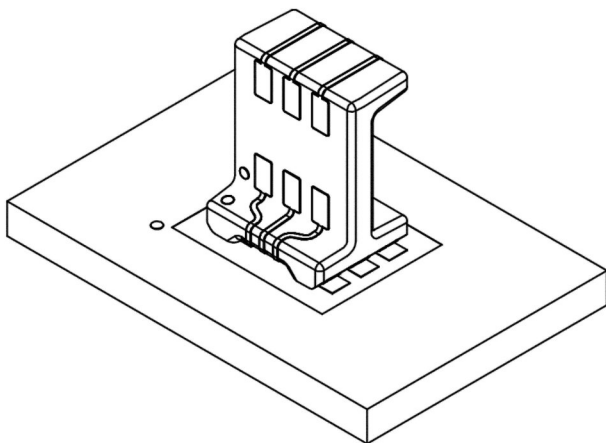

RECOMMENDED PCB PATTERN LAYOUT



Pushing Performance  
 Since 1945

Soldering instructions

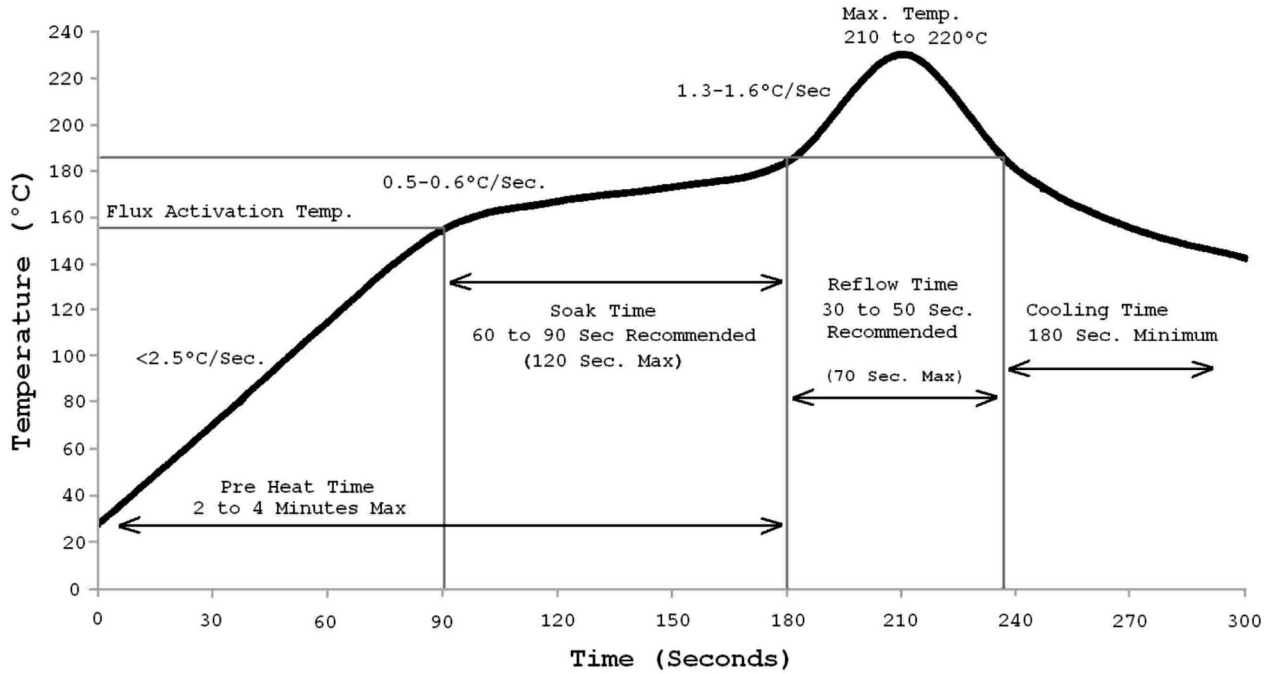

PB-free soldering profile  
 (J-STD-020C)

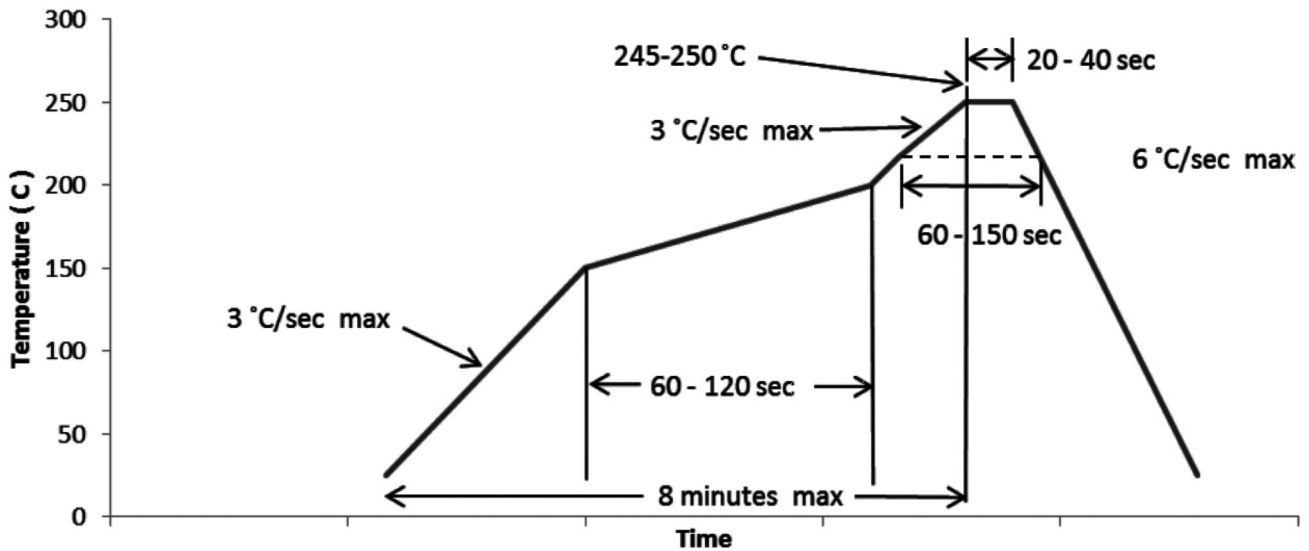



Tape layout & packaging

**BT494030**

MATERIAL	
PS Conductive Black	
surface resistance $10^3 \Omega$ - $10^5 \Omega$	

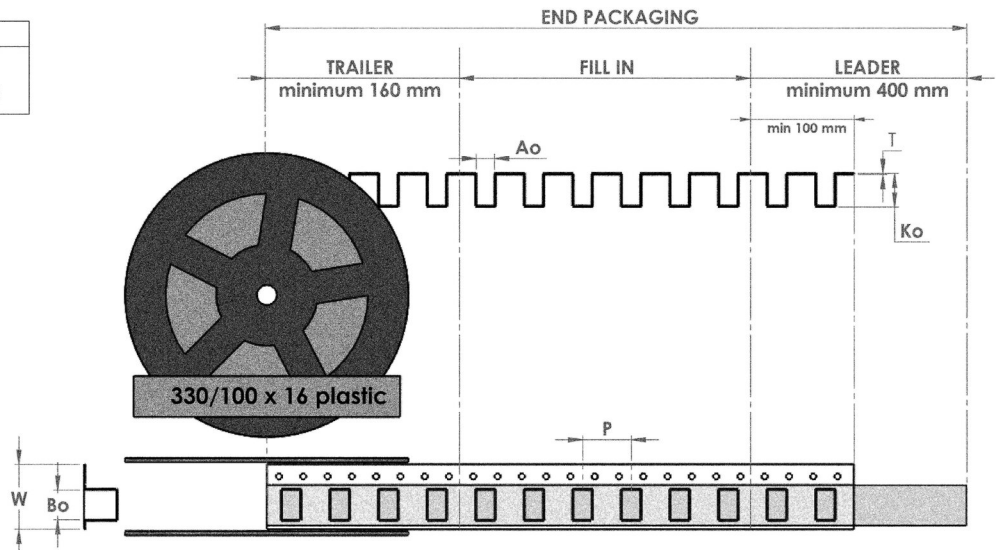
DIMENSIONS	
W	= 16 mm
P	= 8 mm
T	= 0,4 mm
Ao	= 3,3 mm
Bo	= 4,3 mm
Ko	= 5,2 mm
TRAILER	20 cvt
FILL IN	1700 pcs
LEADER	50 cvt

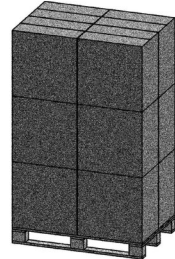

PACKING						
		REEL		BOX		PALLET
LENGTH		42 m		630m		7560 m
CAVITIES		5250 cvt		78750 cvt		945000 cvt
PARTS		3400 pcs [2x1700]		51000 pcs		612000 pcs
WEIGHT		0,63kg		10,71 kg		143,5 kg
QTY		Single Reel		15 reels/box		12 boxes/pallet
DIMENSION		560/76 x 16 cardboard		39 x 58 x 58 [cm]		80 x 120 x 190 [cm]