



RF360 Europe GmbH

A Qualcomm – TDK Joint Venture

## SAW Components

### BAW Bandpass Filter

WLAN 2G

Series/type:	B8852
Ordering code:	B39242B8852P810
Date:	December 18, 2015
Version:	2.0

RF360 products mentioned within this document are offered by RF360 Europe GmbH and other subsidiaries of RF360 Holdings Singapore Pte. Ltd. (collectively, the “RF360 Subsidiaries”). RF360 Holdings Singapore Pte. Ltd. is a joint venture of Qualcomm Global Trading Pte. Ltd. and EPCOS AG. References in this documentation to EPCOS AG should properly reference, and shall be read to reference, the RF360 Subsidiaries.

RF360 Europe GmbH, Anzinger Str. 13, München, Germany

© 2016 RF360 Europe GmbH and/or its affiliated companies. All rights reserved.

These materials, including the information contained herein, may be used only for informational purposes by the customer. The RF360 Subsidiaries assume no responsibility for errors or omissions in these materials or the information contained herein. The RF360 Subsidiaries reserve the right to make changes to the product(s) or information contained herein without notice. The materials and information are provided on an AS IS basis, and the RF360 Subsidiaries assume no liability and make no warranty or representation, either expressed or implied, with respect to the materials, or any output or results based on the use, application, or evaluation of such materials, including, without limitation, with respect to the non-infringement of trademarks, patents, copyrights or any other intellectual property rights or other rights of third parties.

No use of this documentation or any information contained herein grants any license, whether express, implied, by estoppel or otherwise, to any intellectual property rights, including, without limitation, to any patents owned by QUALCOMM Incorporated or any of its subsidiaries.

Not to be used, copied, reproduced, or modified in whole or in part, nor its contents revealed in any manner to others without the express written permission of RF360 Europe GmbH.

Qualcomm and Qualcomm RF360 are trademarks of Qualcomm Incorporated, registered in the United States and other countries. RF360 is a trademark of Qualcomm Incorporated. Other product and brand names may be trademarks or registered trademarks of their respective owners.

This technical data may be subject to U.S. and international export, re-export, or transfer ("export") laws. Diversion contrary to U.S. and international law is strictly prohibited.



## **SAW Components**

### **BAW Bandpass Filter WLAN 2G**

Series/type:	B8852
Ordering code:	B39242B8852P810
Date:	December 18, 2015
Version:	2.0

© EPCOS AG 2015. Reproduction, publication and dissemination of this data sheet, enclosures hereto and the information contained therein without EPCOS' prior express consent is prohibited.

EPCOS AG is a TDK Group Company.

Data sheet

**Table of contents**

1 <a href="#">Application</a> .....	3
2 <a href="#">Features</a> .....	3
3 <a href="#">Package</a> .....	4
4 <a href="#">Pin configuration</a> .....	4
5 <a href="#">Matching circuit</a> .....	5
6 <a href="#">Characteristics</a> .....	6
7 <a href="#">Maximum ratings</a> .....	7
8 <a href="#">Transmission coefficient</a> .....	8
9 <a href="#">Reflection coefficients</a> .....	9
10 <a href="#">Packing material</a> .....	10
11 <a href="#">Marking</a> .....	13
12 <a href="#">Soldering profile</a> .....	15
13 <a href="#">Annotations</a> .....	16
14 <a href="#">Cautions and warnings</a> .....	16
<a href="#">Contact and Important notes</a> .....	17

Data sheet

## 1 Application

- Low-loss BAW RF single filter for Bluetooth/WLAN with LTE Band 7 Rx / Band 40 / Band 38 coexistence.
- Usable passband 79.0 MHz.
- Unbalanced to unbalanced operation.
- Filter impedance 50 Ω.
- High out of band selectivity.
- Excellent insertion loss.

## 2 Features

- Package size 1.1±0.1 mm × 0.9±0.1 mm.
- Package height 0.45 mm (max.).
- Approximate weight 0.0012 g.
- RoHS compatible.
- Package for Surface Mount Technology (SMT).
- Ni/Au-plated terminals.
- Electrostatic Sensitive Device (ESD).
- Moisture Sensitivity Level 3 (MSL3).

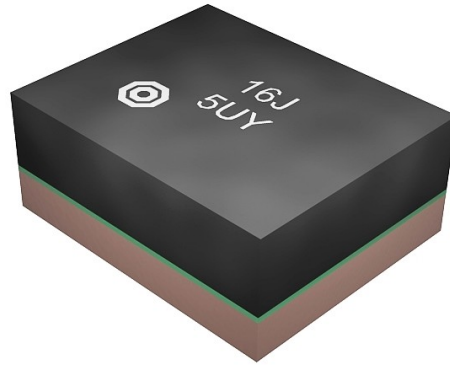
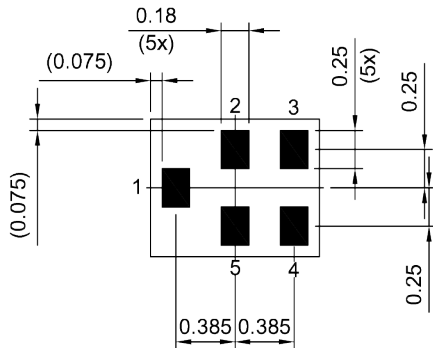

**Figure 1:** Picture of component with example of marking.

Data sheet

3 Package

BOTTOM VIEW



Pad and pitch tolerance ±0.05

4 Pin configuration

- 1 Input (to PA (unbalanced))
- 4 Output (to ANT (unbalanced))
- 2, 3, 5 Ground

SIDE VIEW

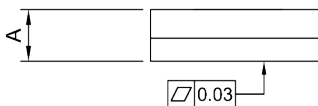

TOP VIEW

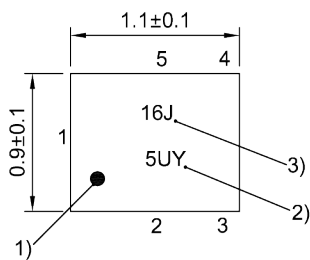

- 1) Marking for pad number 1
- 2) Example of encoded lot number
- 3) Example of encoded filter type number

Land pattern THRU VIEW

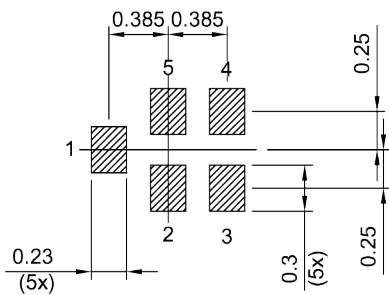

Landing pad tolerance -0.02

**Figure 2:** Drawing of package with package height A = 0.45 mm (max.). See Simplified drawings (p. 16).

Data sheet

### 5 Matching circuit

■  $L_{s1} = 2.0 \text{ nH}$

■  $L_{s4} = 2.0 \text{ nH}$

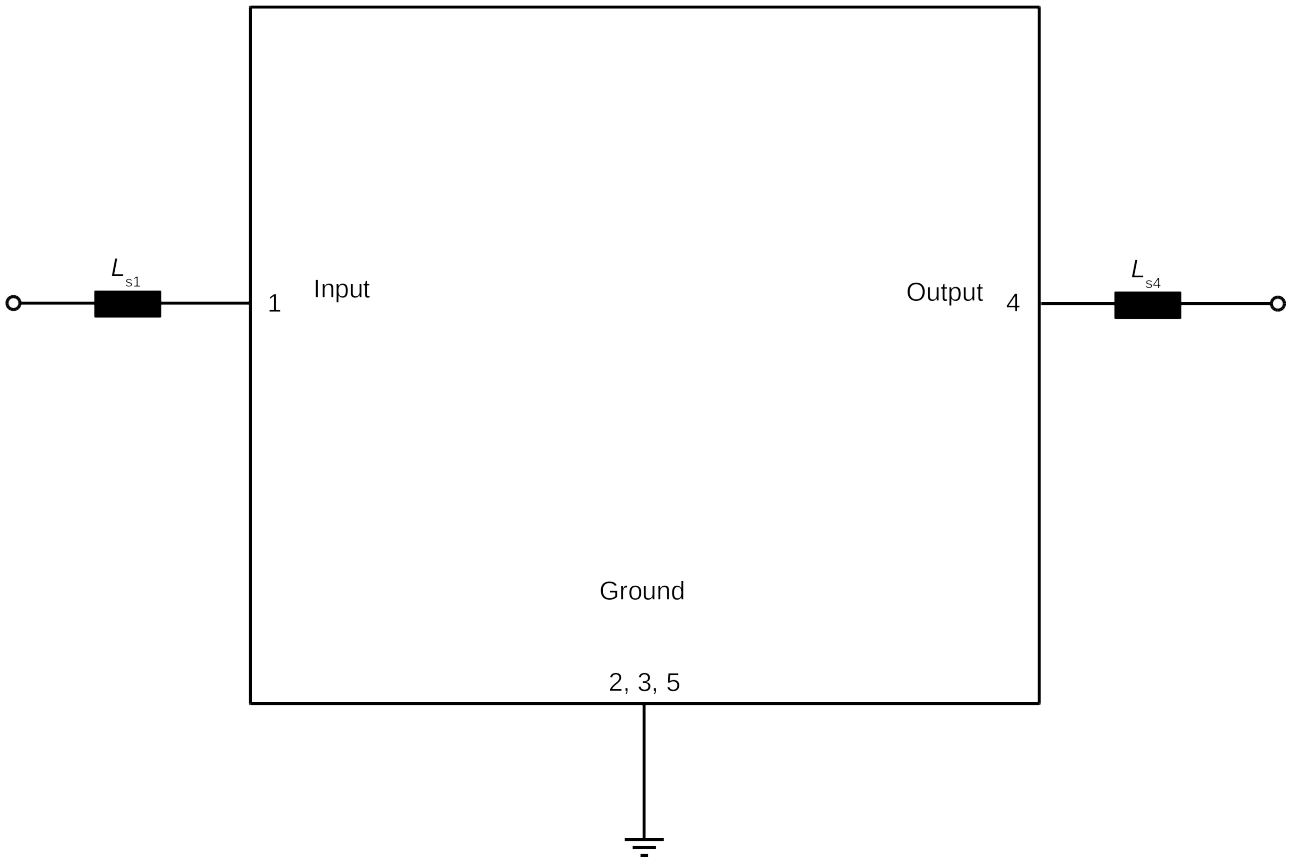

**Figure 3:** Schematic of matching circuit.

Data sheet

## 6 Characteristics

Temperature range for specification	$T$	= -30 °C to +85 °C
Input terminating impedance	$Z_{IN}$	= 50 $\Omega$ with ser. 2.0 nH
Output terminating impedance	$Z_{OUT}$	= 50 $\Omega$ with ser. 2.0 nH

Characteristics		min.	typ. @+25 °C	max.	
<b>Center frequency</b>	$f_c$	—	2442	—	MHz
<b>Maximum insertion attenuation</b>	$\alpha_{max}$				
Channel 1	2403.1... 2420.9 MHz	—	1.0 <sup>1)</sup>	1.8 <sup>1)</sup>	dB
Channel 2	2408.1... 2425.9 MHz	—	0.8 <sup>1)</sup>	1.8 <sup>1)</sup>	dB
Channel 3-10	2413.1... 2465.9 MHz	—	0.7 <sup>1)</sup>	1.8 <sup>1)</sup>	dB
Channel 11	2453.1... 2470.9 MHz	—	0.8 <sup>1)</sup>	1.8 <sup>1)</sup>	dB
Channel 12	2458.1... 2475.9 MHz	—	0.8 <sup>1)</sup>	1.8 <sup>1)</sup>	dB
Channel 13	2463.1... 2480.9 MHz	—	0.9 <sup>1)</sup>	1.8 <sup>1)</sup>	dB
<b>Maximum VSWR</b>	VSWR <sub>max</sub>				
Channel 1-13 @ input port	2403.1... 2480.9 MHz	—	1.6	2.4	
Channel 1-13 @ output port	2403.1... 2480.9 MHz	—	1.6	2.4	
<b>Minimum attenuation</b>	$\alpha_{min}$				
	100... 1805 MHz	27	31	—	dB
	1805... 2170 MHz	29	33	—	dB
	2300... 2360 MHz	39	44	—	dB
	2360... 2365 MHz	38 <sup>2)</sup>	47 <sup>2)</sup>	—	dB
	2365... 2370 MHz	38 <sup>2)</sup>	43 <sup>2)</sup>	—	dB
	2370... 2380 MHz	6 <sup>2)</sup>	41 <sup>2)</sup>	—	dB
	2550... 2570 MHz	39	44	—	dB
	2570... 2620 MHz	34	39	—	dB
	2620... 2690 MHz	33	38	—	dB
	4800... 5805 MHz	35	39	—	dB
	7200... 7500 MHz	30	36	—	dB

1) Averaged value within each Wifi channel width of 17.8 MHz.

2) Averaged values of linear S-parameter over any 5MHz.



<b>SAW Components</b>	<b>B8852</b>
<b>BAW Bandpass Filter</b>	<b>2442 MHz</b>

Data sheet

## 7 Maximum ratings

Storage temperature	$T_{STG} = -40\text{ °C to }+90\text{ °C}$	
DC voltage	$V_{DC} = 5.0\text{ V}^{4)}$	
ESD voltage		
	$V_{ESD}^{1)}$ 50 V	Machine model.
	$V_{ESD}^{2)}$ 300 V	Human body model.
	$V_{ESD}^{3)}$ 600 V	Charged device model.
Input power	$P_{IN}$	
@ input port : 2403.1 ... 2480.9 MHz (WLAN channel 1 to channel 13)	24 dBm	20 MHz OFDM signal for 5000 h @ 65 °C.
@ input port: other frequency range(s)	5.0 dBm	Continuous wave for 5000 h @ 65 °C.

- 1) According to JESD22-A115B (MM – Machine Model), 10 negative & 10 positive pulses.
- 2) According to JESD22-A114F (HBM – Human Body Model), 1 negative & 1 positive pulse.
- 3) According to JESD22-C101C (CDM – Field Induced Charged Device Model), 3 negative & 3 positive pulses.
- 4) 168h Damp Heat Steady State acc. To IEC60068-2-67 Cy.

Data sheet

**8 Transmission coefficient**

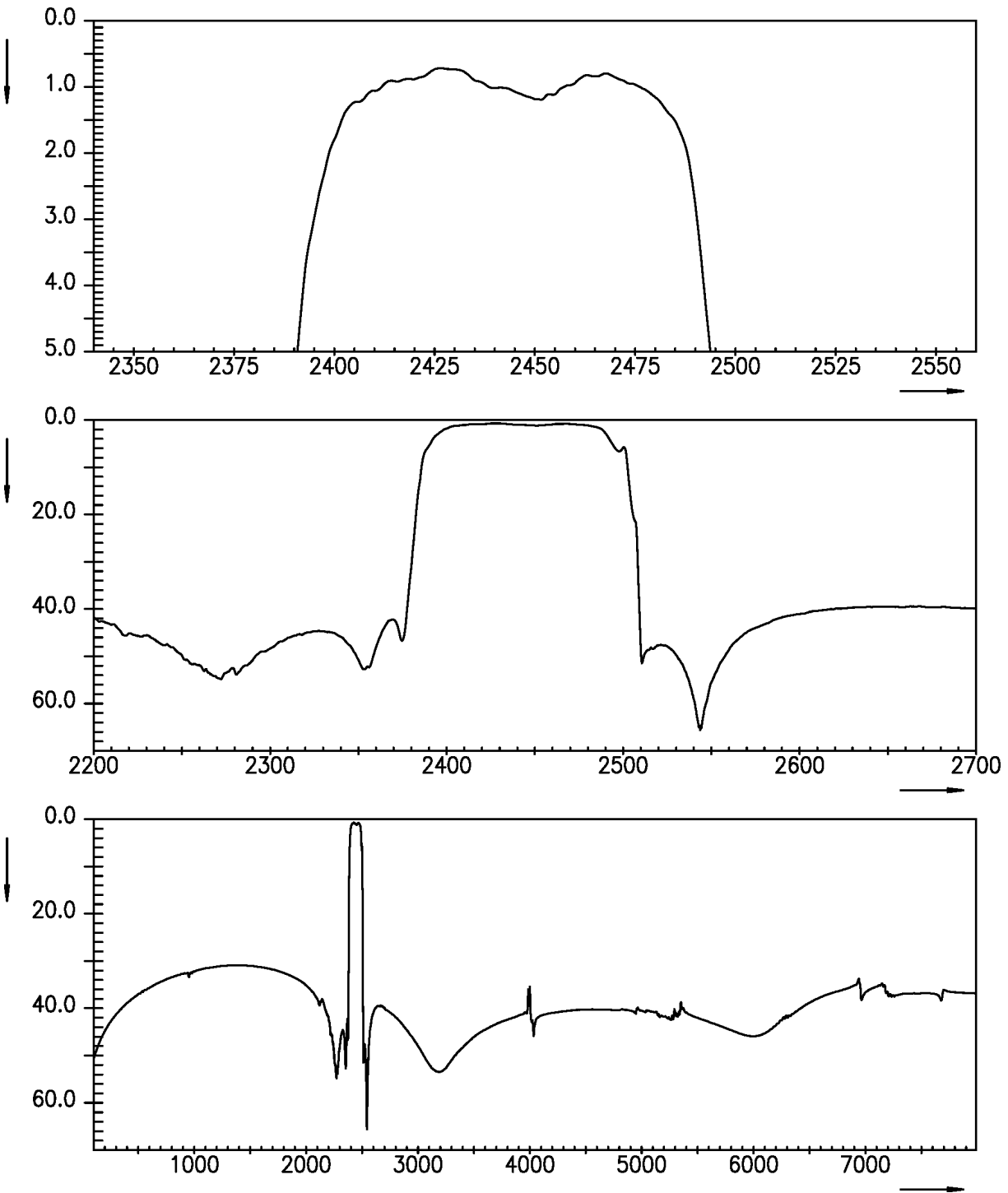

**Figure 4:** Attenuation.

Data sheet

**9 Reflection coefficients**

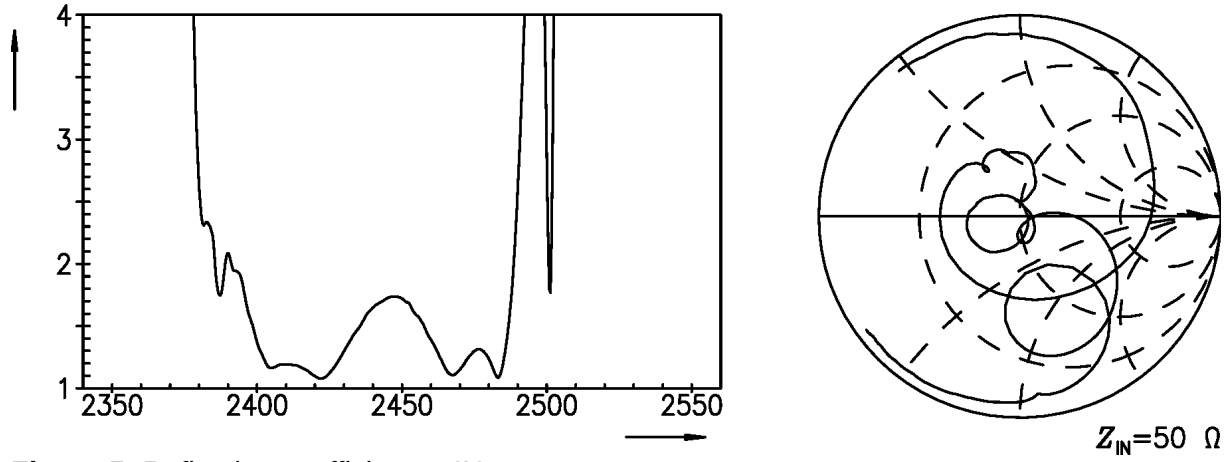

**Figure 5:** Reflection coefficient at IN port.

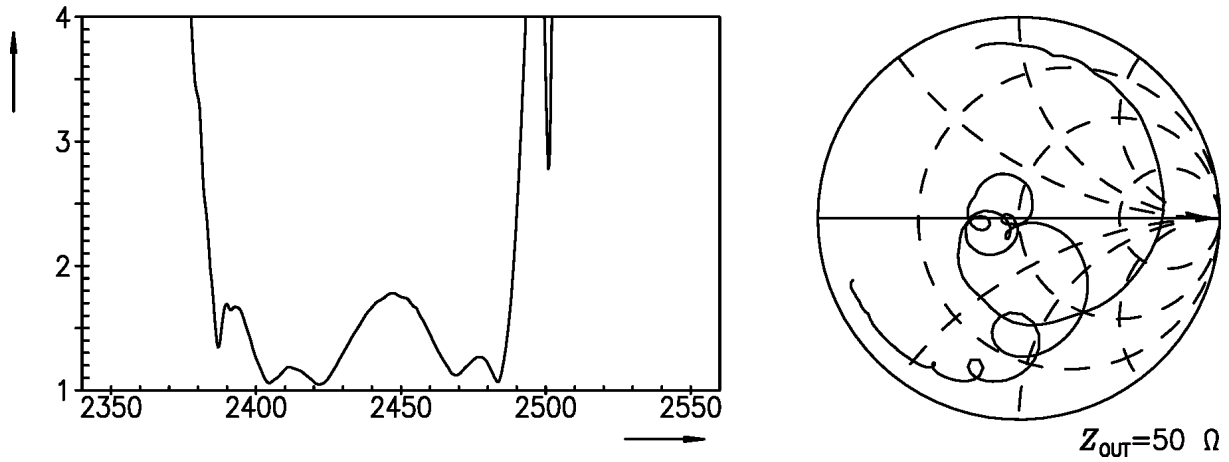
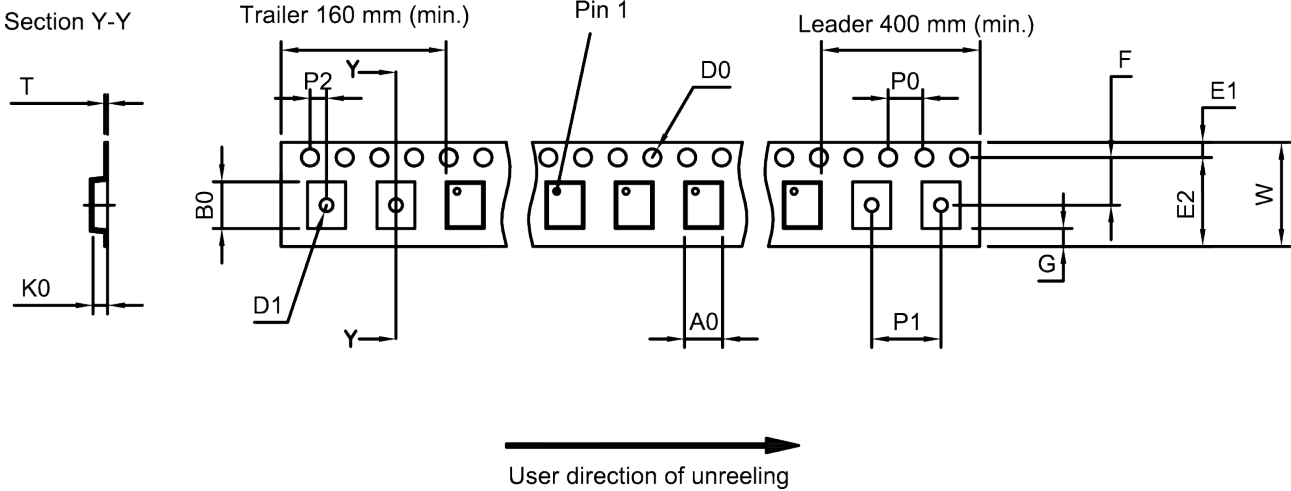

**Figure 6:** Reflection coefficient at OUT port.

Data sheet

**10 Packing material**

**10.1 Tape**



**Figure 7:** Drawing of tape (first-angle projection) with tape dimensions according to Table 1.

A <sub>0</sub>	1.02±0.05 mm
B <sub>0</sub>	1.22±0.05 mm
D <sub>0</sub>	1.55±0.05 mm
D <sub>1</sub>	0.55±0.1 mm
E <sub>1</sub>	1.75±0.1 mm

E <sub>2</sub>	6.25 mm (min.)
F	3.5±0.05 mm
G	–
K <sub>0</sub>	0.6±0.05 mm
P <sub>0</sub>	4.0±0.1 mm

P <sub>1</sub>	2.0±0.1 mm
P <sub>2</sub>	2.0±0.05 mm
T	0.25±0.03 mm
W	8.0+0.3/-0.1 mm

**Table 1:** Tape dimensions.

**10.2 Reel with diameter of 180 mm**

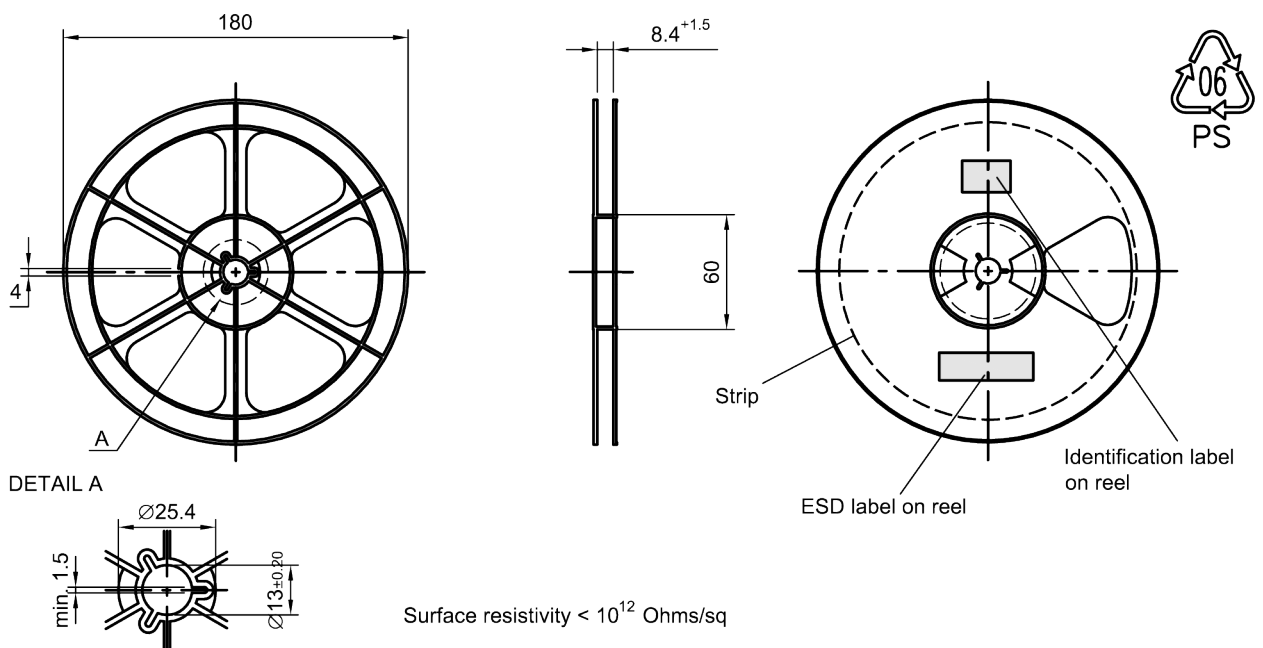

**Figure 8:** Drawing of reel (first-angle projection) with diameter of 180 mm.

Data sheet

Dimensions [mm]

X = 220±5

Y = 235±5

Sealing area 10±3

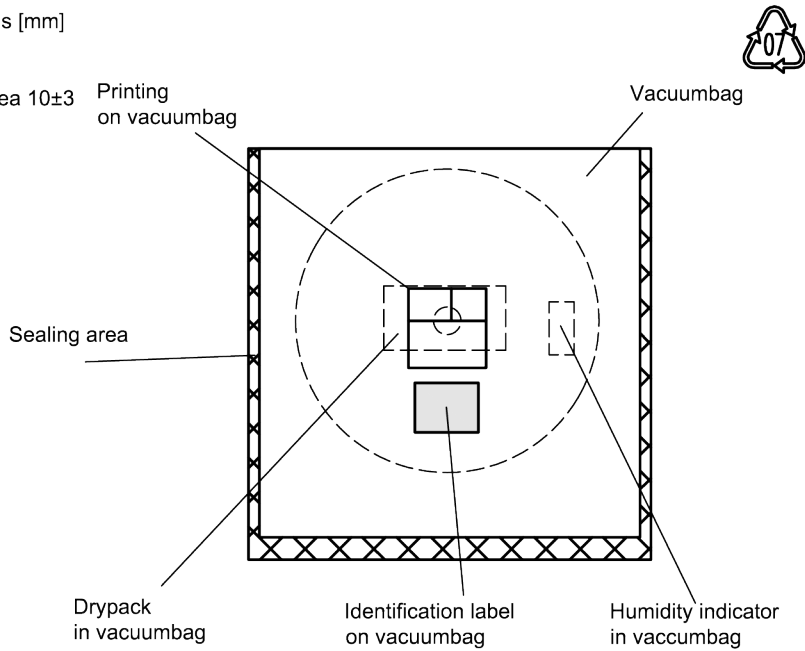

**Figure 9:** Drawing of moisture barrier bag (MBB) for reel with diameter of 180 mm.

Dimensions [mm]

L = 188

B = 188

H = 30

Tolerance ±5

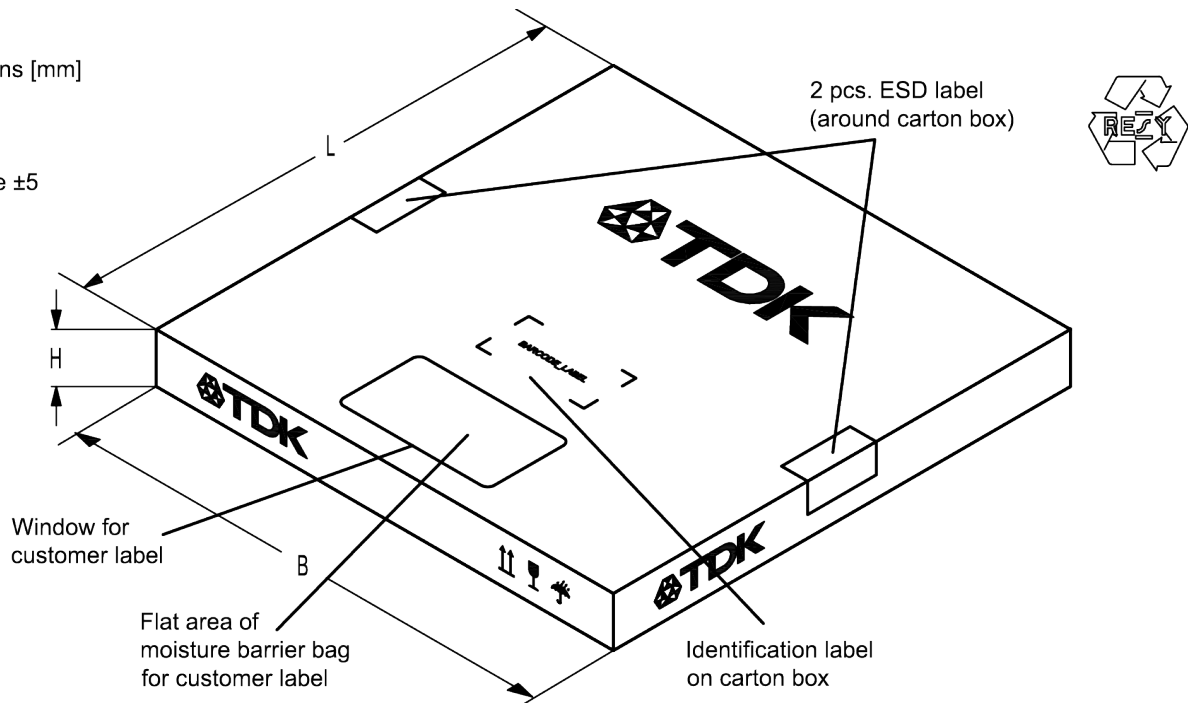

**Figure 10:** Drawing of folding box for reel with diameter of 180 mm.

Data sheet

**10.3 Reel with diameter of 330 mm**

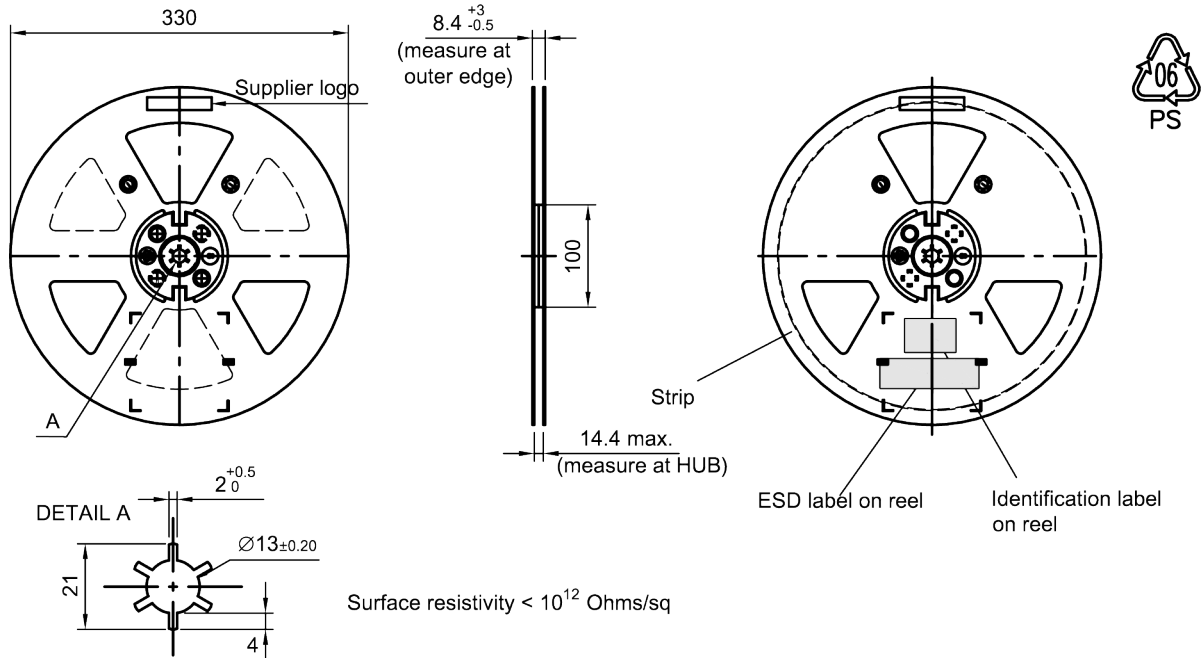

**Figure 11:** Drawing of reel (first-angle projection) with diameter of 330 mm.

Dimensions [mm]  
 X = 400+5  
 Y = 418+5  
 Sealing area 10±3

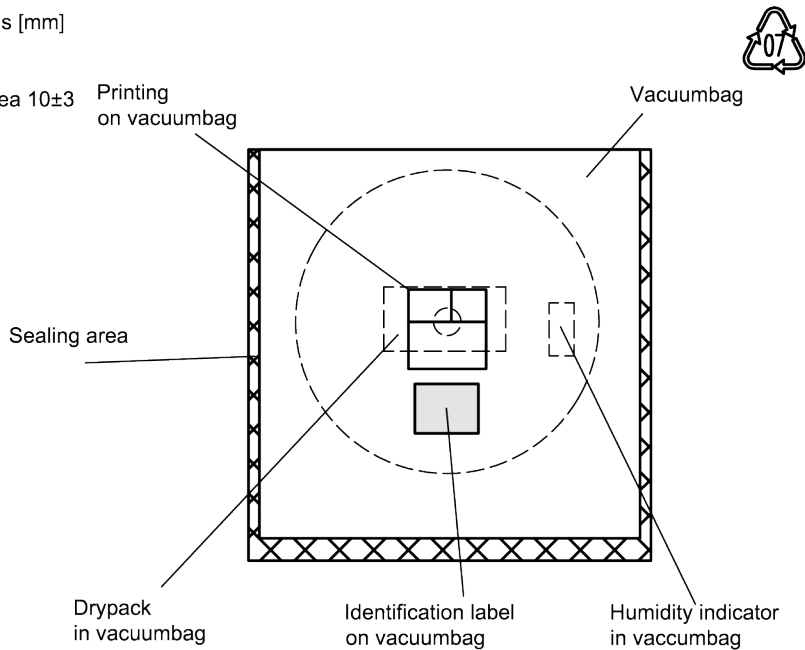

**Figure 12:** Drawing of moisture barrier bag (MBB) for reel with diameter of 330 mm.

## Data sheet

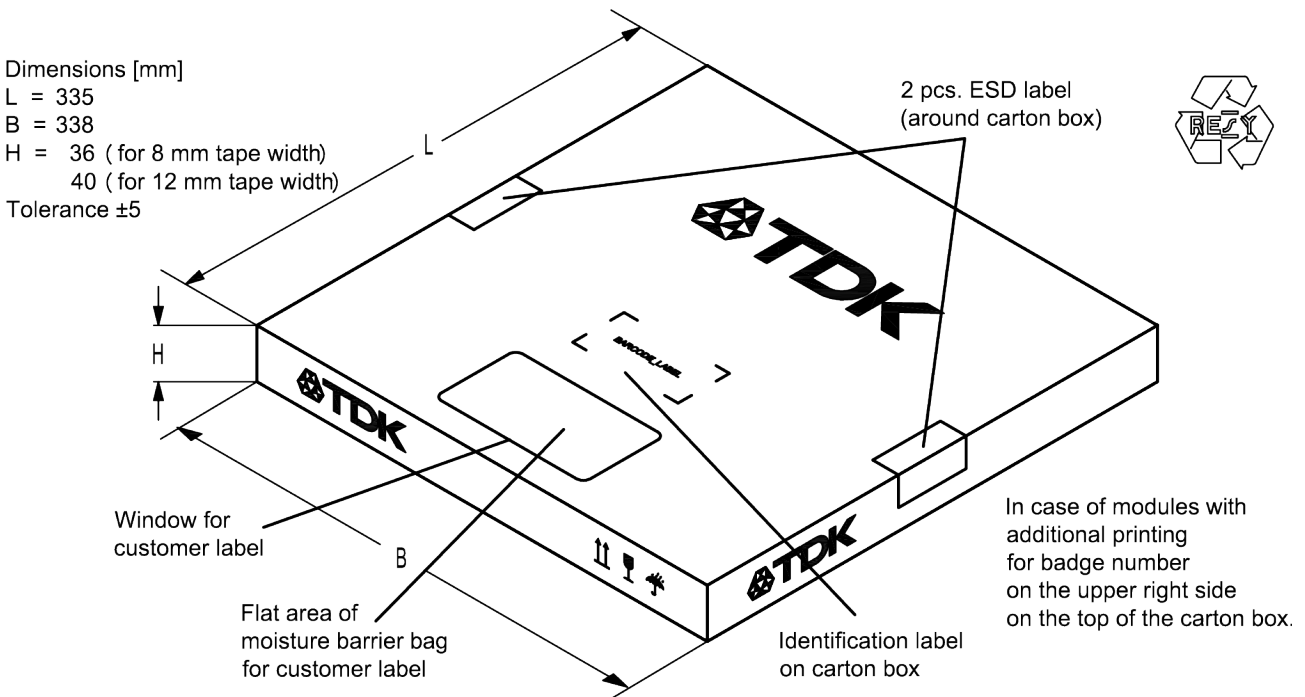
**Figure 13:** Drawing of folding box for reel with diameter of 330 mm.

**11 Marking**

Products are marked with product type number and lot number encoded according to Table 2:

**■ Type number:**

The 4 digit type number of the ordering code, e.g., B3xxxxB**1234**xxxx,  
 is encoded by a special BASE32 code into a 3 digit marking.

Example of decoding type number marking on device in decimal code.

$$\begin{array}{lcl} \mathbf{16J} & \Rightarrow & \mathbf{1234} \\ \mathbf{1 \times 32^2 + 6 \times 32^1 + 18 (=J) \times 32^0} & = & \mathbf{1234} \end{array}$$

The BASE32 code for product type B8852 is 8MM.

**■ Lot number:**

The last 5 digits of the lot number, e.g., **12345**,  
 are encoded based on a special BASE47 code into a 3 digit marking.

Example of decoding lot number marking on device in decimal code.

$$\begin{array}{lcl} \mathbf{5UY} & \Rightarrow & \mathbf{12345} \\ \mathbf{5 \times 47^2 + 27 (=U) \times 47^1 + 31 (=Y) \times 47^0} & = & \mathbf{12345} \end{array}$$

Data sheet

Adopted BASE32 code for type number			
Decimal value	Base32 code	Decimal value	Base32 code
0	0	16	G
1	1	17	H
2	2	18	J
3	3	19	K
4	4	20	M
5	5	21	N
6	6	22	P
7	7	23	Q
8	8	24	R
9	9	25	S
10	A	26	T
11	B	27	V
12	C	28	W
13	D	29	X
14	E	30	Y
15	F	31	Z

Adopted BASE47 code for lot number			
Decimal value	Base47 code	Decimal value	Base47 code
0	0	24	R
1	1	25	S
2	2	26	T
3	3	27	U
4	4	28	V
5	5	29	W
6	6	30	X
7	7	31	Y
8	8	32	Z
9	9	33	b
10	A	34	d
11	B	35	f
12	C	36	h
13	D	37	n
14	E	38	r
15	F	39	t
16	G	40	v
17	H	41	\
18	J	42	?
19	K	43	{
20	L	44	}
21	M	45	<
22	N	46	>
23	P		

**Table 2:** Lists for encoding and decoding of marking.



Data sheet

## 12 Soldering profile

The recommended soldering process is in accordance with IEC 60068-2-58 – 3<sup>rd</sup> edit and IPC/JEDEC J-STD-020B.

ramp rate	≤ 3 K/s
preheat	125 °C to 220 °C, 150 s to 210 s, 0.4 K/s to 1.0 K/s
$T > 220\text{ °C}$	30 s to 70 s
$T > 230\text{ °C}$	min. 10 s
$T > 245\text{ °C}$	max. 20 s
$T \geq 255\text{ °C}$	–
peak temperature $T_{peak}$	250 °C +0/-5 °C
wetting temperature $T_{min}$	230 °C +5/-0 °C for 10 s ± 1 s
cooling rate	≤ 3 K/s
soldering temperature $T$	measured at solder pads

**Table 3:** Characteristics of recommended soldering profile for lead-free solder (Sn95.5Ag3.8Cu0.7).

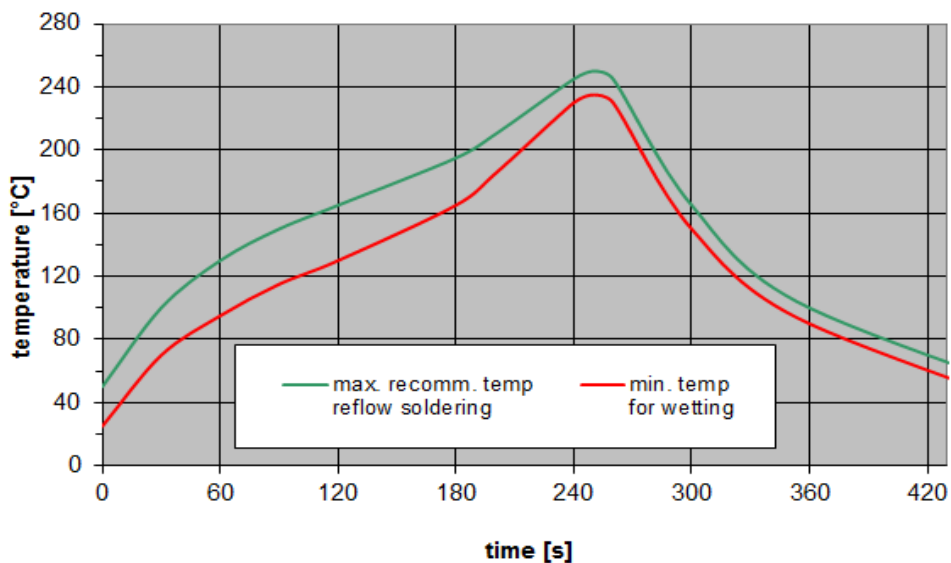

**Figure 14:** Recommended reflow profile for convection and infrared soldering – lead-free solder.

Data sheet

### 13 Annotations

#### 13.1 Matching coils

See TDK inductor pdf-catalog <http://www.tdk.co.jp/tefe02/coil.htm#aname1> and Data Library for circuit simulation <http://www.tdk.co.jp/etvcl/index.htm>.

#### 13.2 RoHS compatibility

ROHS-compatible means that products are compatible with the requirements according to Art. 4 (substance restrictions) of Directive 2011/65/EU of the European Parliament and of the Council of June 8th, 2011, on the restriction of the use of certain hazardous substances in electrical and electronic equipment ("Directive") with due regard to the application of exemptions as per Annex III of the Directive in certain cases.

#### 13.3 Scattering parameters (S-parameters)

The pin/port assignment is available in the headers of the S-parameter files. Please contact your local EPCOS sales office.

#### 13.4 Ordering codes and packing units

Ordering code	Packing unit
B39242B8852P810	15000 pcs
B39242B8852P810S 5	5000 pcs

**Table 4:** Ordering codes and packing units.

### 14 Cautions and warnings

#### 14.1 Display of ordering codes for EPCOS products

The ordering code for one and the same product can be represented differently in data sheets, data books, other publications and the website of EPCOS, or in order-related documents such as shipping notes, order confirmations and product labels. The varying representations of the ordering codes are due to different processes employed and do not affect the specifications of the respective products. Detailed information can be found on the Internet under [www.epcos.com/orderingcodes](http://www.epcos.com/orderingcodes).

#### 14.2 Moldability

Before using in overmolding environment, please contact your local EPCOS sales office.

#### 14.3 Simplified drawings

##### Landing area

The printed circuit board (PCB) land pattern (landing area) shown is based on EPCOS internal development and empirical data and illustrated for example purposes, only. As customers' SMD assembly processes may have a plenty of variants and influence factors which are not under control or knowledge of EPCOS, additional careful process development on customer side is necessary and strongly recommended in order to achieve best soldering results tailored to the particular customer needs.

##### Dimensions

Unless otherwise specified all dimensions are understood using unit millimeter (mm).

##### Projection method

Unless otherwise specified first-angle projection is applied.

Data sheet

### Contact and Important notes

For further information please contact your local EPCOS sales office or visit our web page at [www.epcos.com](http://www.epcos.com).

**Published by EPCOS AG**  
**Systems, Acoustics, Waves Business Group**  
**P.O. Box 80 17 09, 81617 Munich, GERMANY**

© EPCOS AG 2015. This brochure replaces the previous edition.

For questions on technology, prices and delivery please contact the sales offices of EPCOS AG or the international representatives.

Due to technical requirements components may contain dangerous substances. For information on the type in question please also contact one of our sales offices.

## Important notes

The following applies to all products named in this publication:

1. Some parts of this publication contain **statements about the suitability of our products for certain areas of application**. These statements are based on our knowledge of typical requirements that are often placed on our products in the areas of application concerned. We nevertheless expressly point out **that such statements cannot be regarded as binding statements about the suitability of our products for a particular customer application**. As a rule, EPCOS is either unfamiliar with individual customer applications or less familiar with them than the customers themselves. For these reasons, it is always ultimately incumbent on the customer to check and decide whether an EPCOS product with the properties described in the product specification is suitable for use in a particular customer application.
2. We also point out that **in individual cases, a malfunction of electronic components or failure before the end of their usual service life cannot be completely ruled out in the current state of the art, even if they are operated as specified**. In customer applications requiring a very high level of operational safety and especially in customer applications in which the malfunction or failure of an electronic component could endanger human life or health (e.g. in accident prevention or life-saving systems), it must therefore be ensured by means of suitable design of the customer application or other action taken by the customer (e.g. installation of protective circuitry or redundancy) that no injury or damage is sustained by third parties in the event of malfunction or failure of an electronic component.
3. **The warnings, cautions and product-specific notes must be observed.**
4. In order to satisfy certain technical requirements, **some of the products described in this publication may contain substances subject to restrictions in certain jurisdictions (e.g. because they are classed as hazardous)**. Useful information on this will be found in our Material Data Sheets on the Internet ([www.epcos.com/material](http://www.epcos.com/material)). Should you have any more detailed questions, please contact our sales offices.
5. We constantly strive to improve our products. Consequently, **the products described in this publication may change from time to time**. The same is true of the corresponding product specifications. Please check therefore to what extent product descriptions and specifications contained in this publication are still applicable before or when you place an order. We also **reserve the right to discontinue production and delivery of products**. Consequently, we cannot guarantee that all products named in this publication will always be available.  
The aforementioned does not apply in the case of individual agreements deviating from the foregoing for customer-specific products.
6. Unless otherwise agreed in individual contracts, **all orders are subject to the current version of the “General Terms of Delivery for Products and Services in the Electrical Industry” published by the German Electrical and Electronics Industry Association (ZVEI)**.
7. The trade names EPCOS, Alu-X, CeraDiode, CeraLink, CeraPad, CeraPlas, CSMP, CSSP, CTVS, DeltaCap, DigiSiMic, DSSP, ExoCore, FilterCap, FormFit, LeaXield, MiniBlue, MiniCell, MKD, MKK, MotorCap, PCC, PhaseCap, PhaseCube, PhaseMod, PhiCap, PQSine, SIFERRIT, SIFI, SIKOREL, SilverCap, SIMDAD, SiMic, SIMID, SineFormer, SIOV, SIP5D, SIP5K, TFAP, ThermoFuse, WindCap are **trademarks registered or pending** in Europe and in other countries. Further information will be found on the Internet at [www.epcos.com/trademarks](http://www.epcos.com/trademarks).