

© 1963 BY AMP INCORPORATED. ALL RIGHTS RESERVED. AMP PRODUCTS COVERED BY PATENTS AND/OR PATENTS PENDING.

330600

REVISIONS			
SYM	DESCRIPTION	DATE	APPD
A	TAN. RAD. ON TONGUE	10-2-63	JH
B	PER P-8292	1-30-79	JH
C	REV. PER P-8347	REB. 4/9/79	JH
D	REV G-4680	TMS 5-9-82 E-003	JT

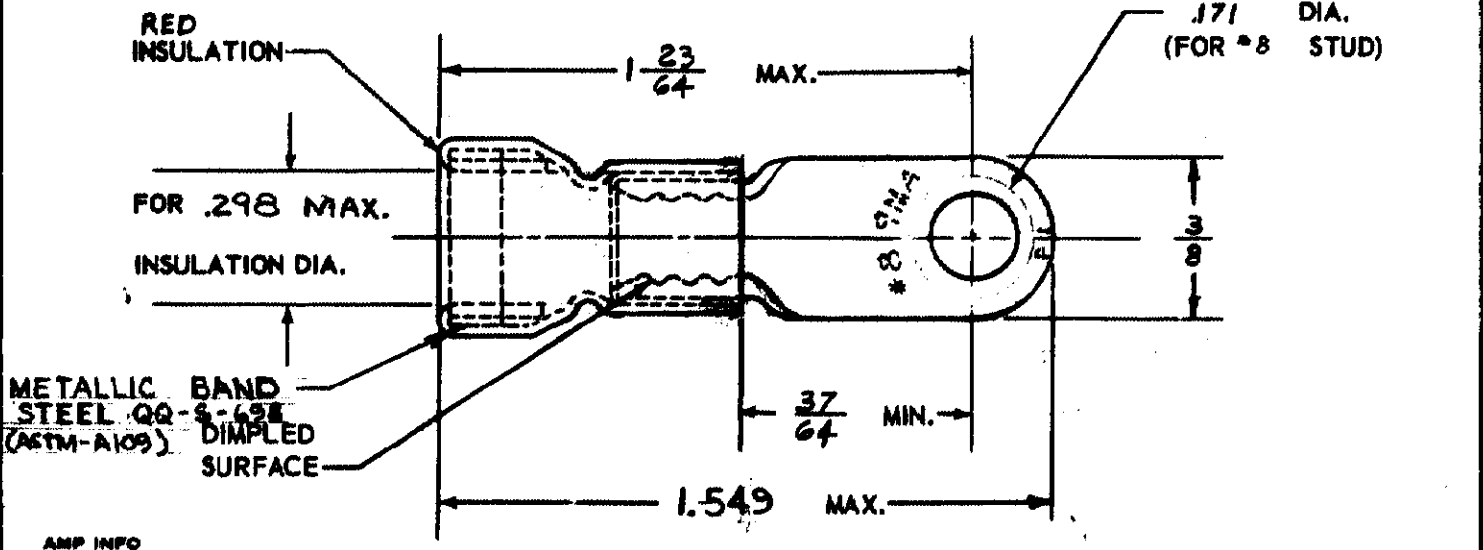

TONGUE MATERIAL THICKNESS .040

AMP INFO

LOC G

PRINTED 14

DATE 10

UNLESS OTHERWISE SPECIFIED		
DIMENSIONS ARE IN INCHES		
TOLERANCES ON		
FRACTIONS	DECIMALS	ANGLES
± 1/64	± .015	± 5°
MATERIAL TERMINAL	SLEEVE	
COPPER (MIL-Q.Q-C-576)	P.V.C. INSULATION	
HEAT TREAT		
ANNEALED		
FINISH		
TIN PLATED (MIL-T-10727)	NONE	

AMP

AMP INCORPORATED
HARRISBURG, PENNSYLVANIA

SIGNATURE	DATE
DR <i>T. Lanthier</i>	8-15-63
CHK <i>J.W. Haines</i>	8/19/63
DESIGNOR	
APPD <i>J.W. Haines</i>	8/19/63

NAME

WIRE TERMINAL

AMPLI-BOND*

RING TONGUE

WIRE SIZE 8

DESIGN APPD	CODE IDENT NO	SIZE	NUMBER
	00779	A	330600
OTHER APPD	SCALE 2:1	WT	CALC ACTUAL SHEET 1 OF 1