

4

3

2

1

THIS DRAWING IS UNPUBLISHED. RELEASED FOR PUBLICATION .19  
 © COPYRIGHT 19 BY AMP INCORPORATED. ALL RIGHTS RESERVED.

LOC	DIST	REVISIONS			
P	LTR	DESCRIPTION	DATE	DWN	APVD
AA	27				
	B	REDWN & REV; OG1Z-0042-99	12MAY00	LH	LS

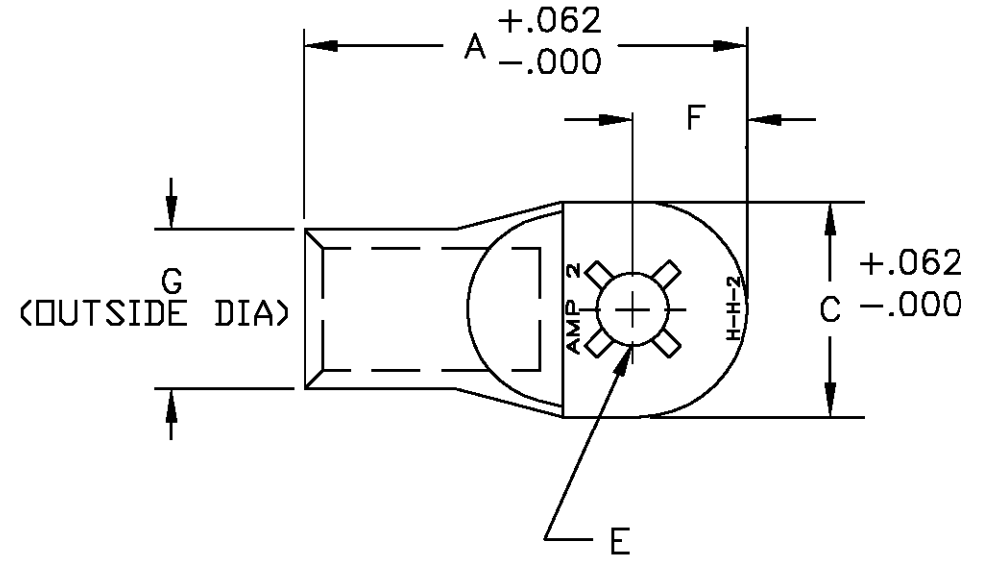

1. LOCKING LANCE FOR -3 ONLY.

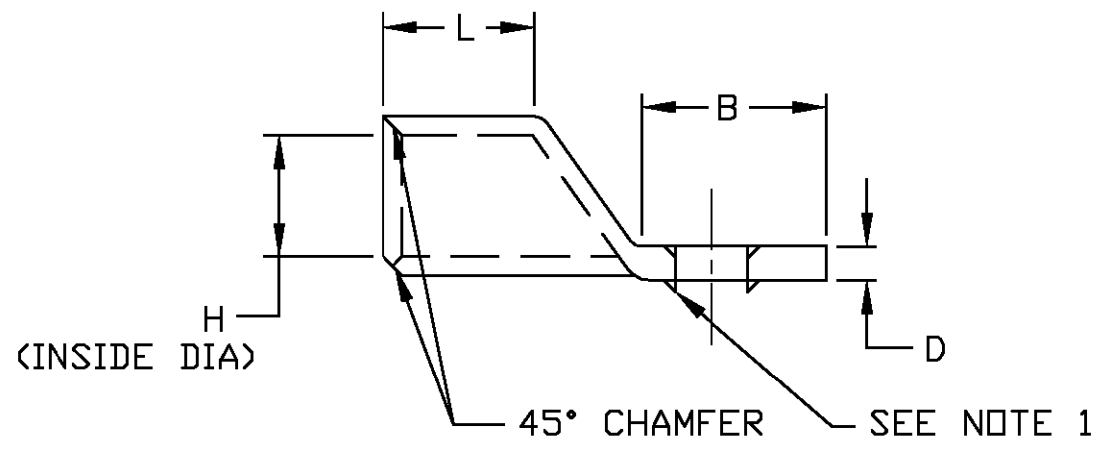

.375	.75	.375	.516	.438	Ø.391	.135	.750	1.00	2.14	606290-5
.500	.75	.375	.516	.500	Ø.516	.135	.859	1.150	2.25	606290-4
.375	.75	.375	.516	.438	Ø.391	.135	.719	1.00	2.14	606290-3
.312	.75	.375	.516	.438	Ø.328	.135	.719	.94	2.14	606290-2
.250	.75	.375	.516	.438	Ø.266	.135	.719	.94	2.14	606290-1
BOLT HOLE SIZE	L	H	G	F	E	D	C	B	A	PART NUMBER

THIS DRAWING IS A CONTROLLED DOCUMENT.		DWN L. HALL 18APR00	AMP Incorporated Harrisburg PA 17105-3608	
DIMENSIONS: INCHES	TOLERANCES UNLESS OTHERWISE SPECIFIED:	CHK L.H. SMITH 12MAY00	AMP TUBULAR TERMINAL 2 AWG	
	0 PLC ±	APVD B. ANTHONY 12MAY00	AMP	
	1 PLC ±	PRODUCT SPEC	NOT the LATEST REVISION	
	2 PLC ±.02	APPLICATION SPEC	SIZE A3	CAGE CODE 00779
	3 PLC ±.005	WEIGHT	DRAWING NO C=606290	RESTRICTED TO
	4 PLC ±.0005	CUSTOMER DRAWING	SCALE NTS	SHEET 1 OF 1
	ANGLES ±.3°		REV B	
MATERIAL HIGH CONDUCTIVITY WROUGHT COPPER	FINISH ELECTRO TIN PLATE			

AMP 1470-19 REV 23FEB95