

THIS IS A C.A.D. GENERATED DRAWING  
DO NOT MAKE MANUAL REVISIONS TO MASTER.



\* UNLESS OTHERWISE SPECIFIED TOLERANCES  
ON DECIMAL IS:  
UNIT: MM  
DIM TOL DIM TOL  
X. ±0.15 X. ±2.0°  
X.X ±0.10 X.X ±1.0°  
X.XX ±0.05 X.XX ±0.5°  
X.XXX ±0.03 X.XXX ±0.3°

ISSUE NUMBER

ORIGINAL ①

ADD NOTE 2 & 3.  
ADD UNPLATED P/N ②  
Peter Deng JUN.26/19

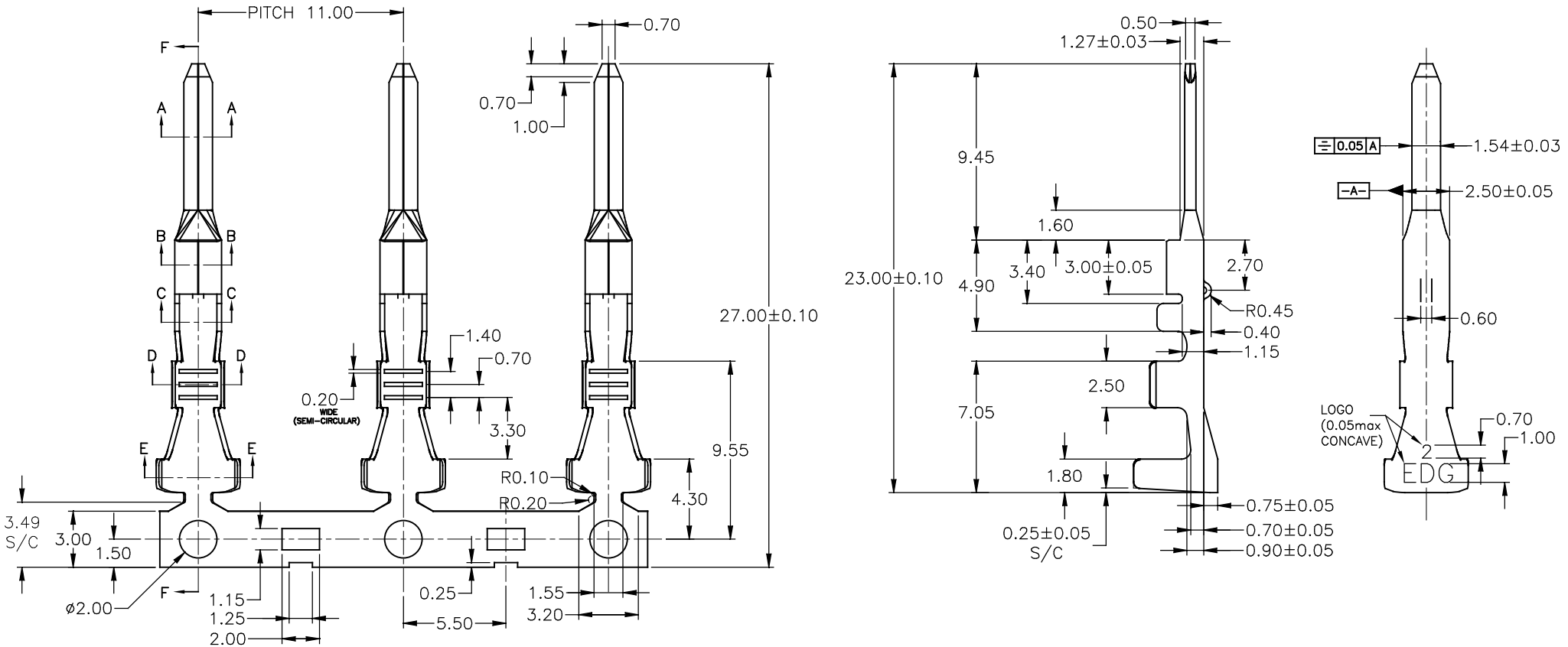

570-292-751	570-290-751	4.4±0.20	3.3±0.20	4.5±0.20	3.3±0.20	R1.60±0.05	R0.85±0.05	Brass C2680 H	AWG #14	ø3.10 max	4,000
570-293-731	570-291-731	4.4±0.20	2.8±0.20	4.5±0.20	2.8±0.20	R1.60±0.05	R0.75±0.05	Phosphor bronze C5191 1/2 H	AWG #20-16	ø3.10 max	4,000
570-292-731	570-290-731	4.4±0.20	2.8±0.20	4.5±0.20	2.8±0.20	R1.60±0.05	R0.75±0.05	Brass C2680 H	AWG #20-16	ø3.10 max	4,000
570-292-711	570-290-711	4.4±0.20	2.2±0.20	4.5±0.20	2.2±0.20	R1.40±0.05	R0.55±0.05	Brass C2680 H	AWG #22-20	ø2.70 max	4,000
UN-PLATED PART NO.	PLATED PART NO.	A1	A2	B1	B2	C1	C2	MATERIALS	AWG #	INS. DIA.	PCS/REEL

NOTES:

1. MATERIAL: SEE TABLE, 0.25mm THICK.
2. PLATING: 100-200 MICROINCHES OF BRIGHT TIN PLATING ALL OVER NICKEL 50-150 MICROINCHES UNDERPLATING.
3. SALT SPRAY TEST MUST BE NO CORROSION AFTER 24H.
4. PART SHALL BE FREE OF BURRS NOT EXCEEDING 0.02mm NO CRACKS ALLOW ON ANY SURFACES.

570 SERIES MALE CONTACT



EDAC INC  
TORONTO, ONTARIO  
CANADA

YOUR CONNECTION TO QUALITY & SERVICE

THESE DRAWINGS AND SPECIFICATIONS  
ARE THE PROPERTY OF EDAC INC. AND  
SHALL NOT BE REPRODUCED, OR COPIED  
OR USED AS THE BASIS FOR THE  
MANUFACTURE OR SALE OF APPARATUS  
WITHOUT WRITTEN PERMISSION.

ACAD REFERENCE NO. 570-29Y-7Y1

DRAWN: Haley Hu

DATE: MAY.16/15

CHECKED:

DATE:

SCALE: (IN C.A.D. 1:1)

SHEET 1 OF 2

DRAWING NUMBER

570-29Y-7Y1

ISSUE

8

THIS IS A C.A.D. GENERATED DRAWING  
DO NOT MAKE MANUAL REVISIONS TO MASTER.



\* UNLESS OTHERWISE SPECIFIED TOLERANCES

ON DECIMAL IS:

UNIT: MM			
DIM	TOL	DIM	TOL
X.	±0.15	X°	±2.0°
X.X	±0.10	X.X°	±1.0°
X.XX	±0.05	X.XX°	±0.5°
X.XXX	±0.03	X.XXX°	±0.3°

ISSUE NUMBER

ORIGINAL (1)

SEE SHEET 1 (2)  
Peter Deng JUN.26/19

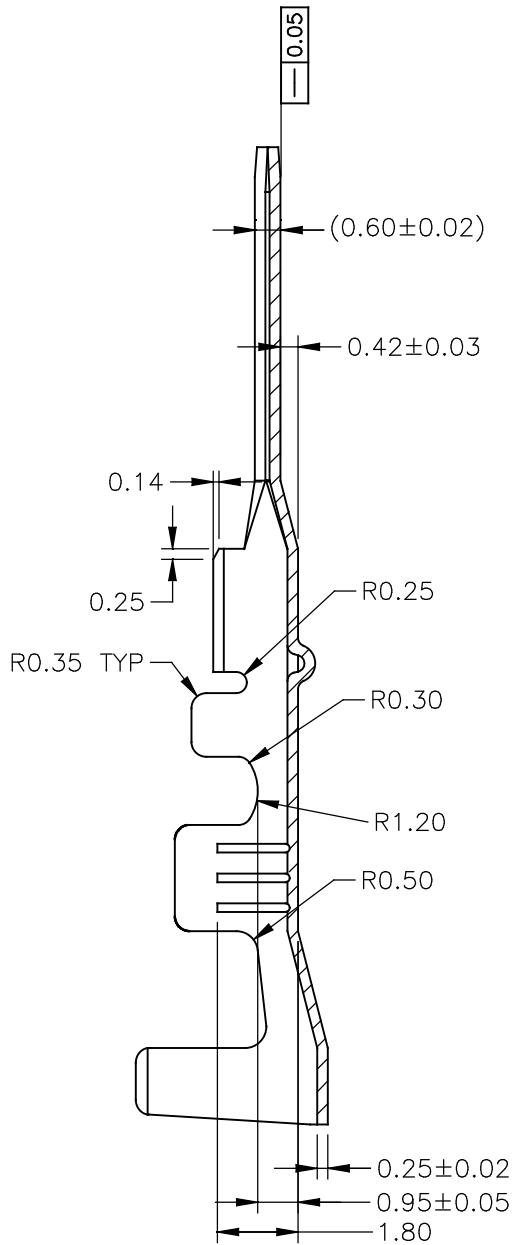

SECTION F-F  
SCALE 1:1

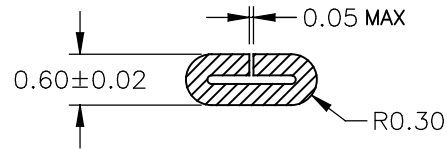

SECTION A-A  
SCALE 2:1

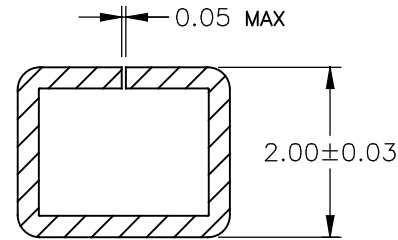

SECTION B-B  
SCALE 2:1

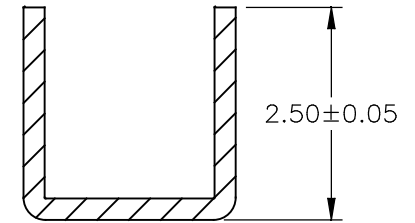

SECTION C-C  
SCALE 2:1

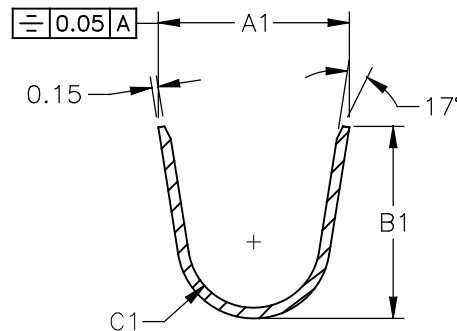

SECTION E-E  
SCALE 1:1

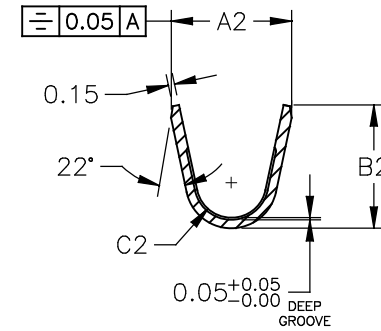

SECTION D-D  
SCALE 1:1

570 SERIES MALE CONTACT

ACAD REFERENCE NO. 570-29Y-7Y1

DRAWN: Haley Hu

DATE: MAY.16/15

CHECKED:

DATE:

SCALE: (IN C.A.D. 1:1)

SHEET 2 OF 2

DRAWING NUMBER

570-29Y-7Y1

ISSUE

8



EDAC INC  
TORONTO, ONTARIO  
CANADA

YOUR CONNECTION TO QUALITY & SERVICE

THESE DRAWINGS AND SPECIFICATIONS  
ARE THE PROPERTY OF EDAC INC. AND  
SHALL NOT BE REPRODUCED, OR COPIED  
OR USED AS THE BASIS FOR THE  
MANUFACTURE OR SALE OF APPARATUS  
WITHOUT WRITTEN PERMISSION.