

LED Drivers for LCD Backlights

# 1ch Boost Up Type White LED Driver for Large LCD

## BD9408FV

### General Description

BD9408FV is a high efficiency driver for white LEDs and it is designed for large LCDs. BD9408FV has a boost DC/DC converter that can supply appropriate voltage to the light source of LEDs series array.

BD9408FV has some protect functions against fault conditions, such as over voltage protection(OVP), over current limit protection of DC/DC(OCP), LED OCP protection, and over boost protection(FBMAX). Therefore, it is available for a wide range output voltage and a wide range load current.

### Features

- DC/DC Converter with Current Mode
- LED Protection Circuit(Over Boost Protection, LED OCP Protection)
- Over Voltage Protection(OVP) for the Output Voltage
- Adjustable Soft Start
- Adjustable Oscillation Frequency of DC/DC
- Wide Range of Analog Dimming 0.2V to 3.0V
- LED Dimming PWM Over Duty Protection(ODP)

### Applications

- TV, Computer Display
- Other LCD Backlighting

### Key Specifications

- Operating Power Supply Voltage Range: 9.0V to 35.0V
- Oscillator Frequency of DC/DC: 150kHz( $R_{RT}=100k\Omega$ )
- Operating Current: 3mA(Typ)
- Operating Temperature Range: -40°C to +105°C

### Package

SSOP-B14

### W(Typ) x D(Typ) x H(Max)

5.00mm x 6.40mm x 1.35mm



### Typical Application Circuit

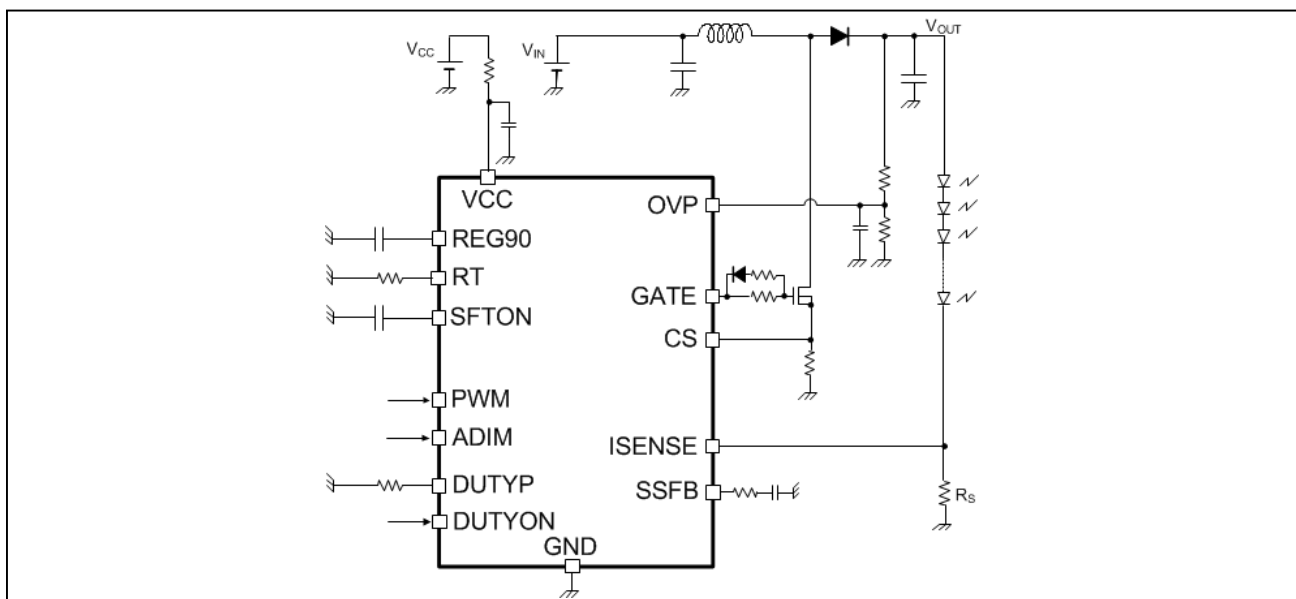

## Contents

General Description .....	1
Features.....	1
Applications .....	1
Key Specifications .....	1
Package.....	1
Typical Application Circuit .....	1
Contents .....	2
Pin Configuration .....	3
Pin Descriptions.....	3
Block Diagram .....	4
Description of Pin Function .....	5
Absolute Maximum Ratings .....	8
Thermal Resistance.....	8
Recommended Operating Conditions.....	8
Electrical Characteristics.....	9
Typical Performance Curves.....	11
List of Protection Detection Condition.....	12
List of Protection Function Operation.....	12
Timing Chart .....	13
Application Examples .....	19
Selection of Components Externally Connected.....	20
I/O Equivalent Circuits .....	28
Operational Notes.....	29
Ordering Information.....	31
Marking Diagram .....	31
Physical Dimension and Packing Information .....	32
Revision History.....	33

## Pin Configuration

(TOP VIEW)

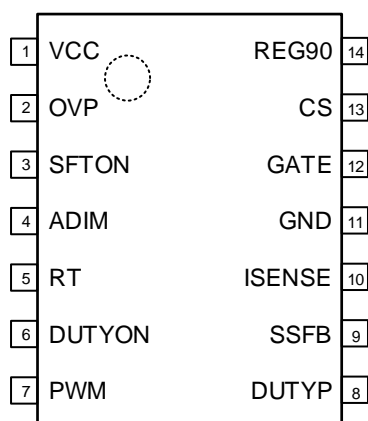

## Pin Descriptions

Pin No.	Pin Name	Function
1	VCC	Power supply voltage input
2	OVP	Over voltage protection detection
3	SFTON	PWM dimming soft start setting
4	ADIM	Analog dimming signal input
5	RT	DC/DC switching frequency setting
6	DUTYON	Over duty protection ON/OFF
7	PWM	External PWM dimming signal input
8	DUTYP	Over duty protection setting
9	SSFB	Soft start setting, error amplifier output
10	ISENSE	LED current sensing
11	GND	GND
12	GATE	MOSFET GATE signal
13	CS	Inductor current sensing
14	REG90	9.0V output voltage

Block Diagram

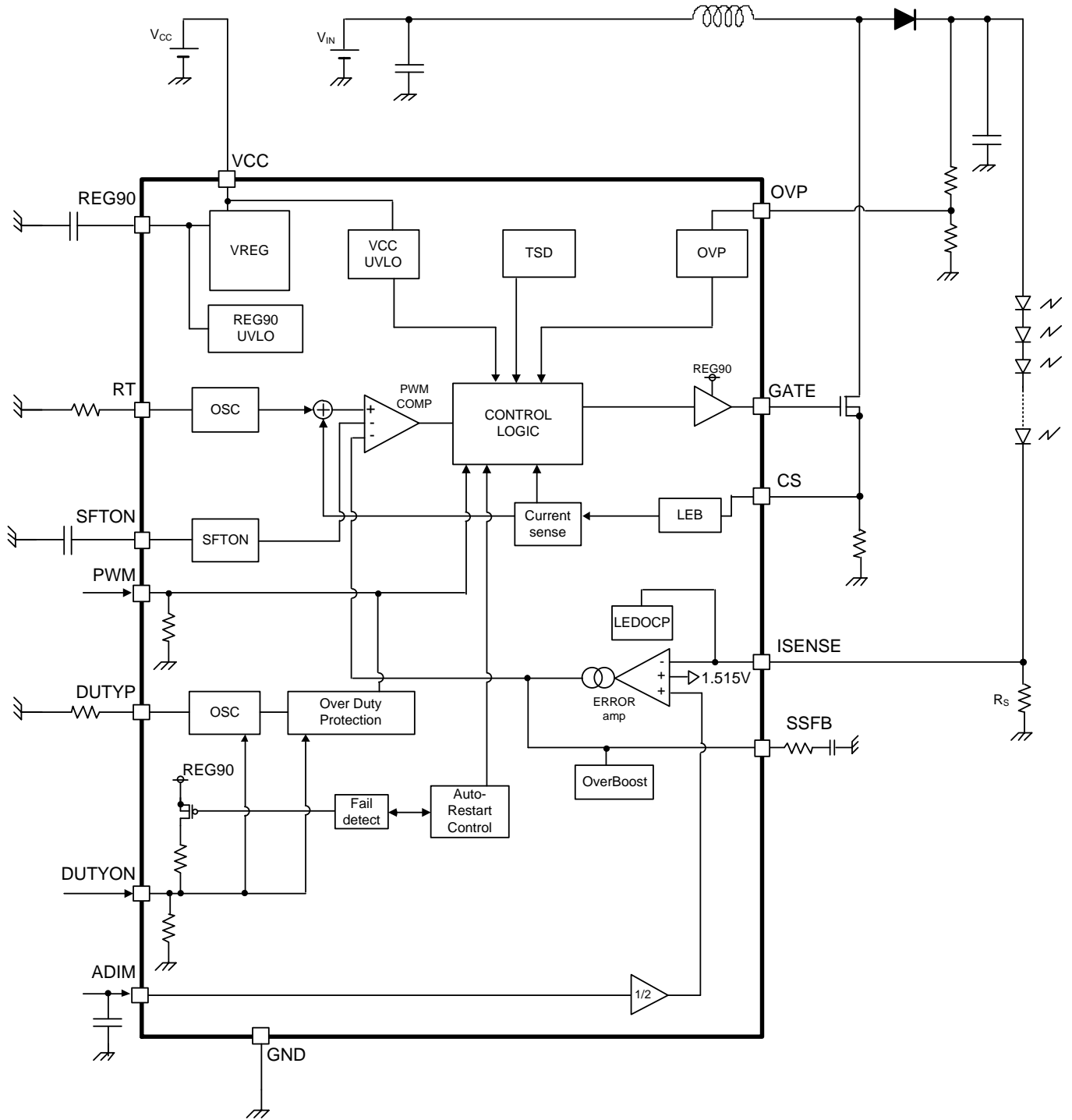

## Description of Pin Function

If there is no description, the mentioned values are typical value.

### Pin 1: VCC

This is the power supply pin of the IC. Input range is from 9V to 35V.  
The operation starts at 7.5V or more and shuts down at less than 7.2V.

### Pin 2: OVP

The OVP pin is the input for over voltage protection. If  $V_{OVP} \geq 3.0V$ , the over voltage protection will work. At the moment of these detections, it sets GATE=L and starts to count up the abnormal interval. If OVP detection continues to count 4 GATE clks, IC reaches latch off. (Refer to "[Timing Chart OVP Detection](#)") The OVP pin is high impedance, because the internal resistance is not connected to a certain bias.  
Even if OVP function is not used, input appropriate voltage because the open connection of this pin is not a fixed voltage.  
The setting example is separately described in the section "[OVP Setting](#)".

### Pin 3: SFTON

The SFTON pin sets the soft start time for LED electric current at PWM=L to PWM=H. It performs the constant current charge of 30.0μA to external capacitance  $C_{SFTON}$ (external capacitance of SFTON). The switching duty of GATE output will be limited during 0V to SSFB voltage of the SFTON voltage. So the soft on interval  $t_{SFTON}$  can be expressed as follows.

$$t_{SFTON} = \frac{C_{SFTON} \times V_{SSFB}}{30 \times 10^{-6}} \quad [s]$$

where:

$t_{SFTON}$  is the operation period of soft on.  
 $C_{SFTON}$  is the external capacitance of the SFTON pin.  
 $V_{SSFB}$  is the SSFB pin voltage.

### Pin 4: ADIM

This is the input pin for analog dimming signal. The ISENSE feedback voltage is set as 1/2 of this pin voltage. If  $V_{ADIM} \geq 3.03V$ , ISENSE feedback voltage is clamped to limit to flow LED large current. In this condition, the input current is caused. Refer to "[ISENSE pin explanation](#)".

### Pin 5: RT

This is the DC/DC switching frequency setting pin. DC/DC switching frequency is decided by connected resistor.  
oRelation between Drive Frequency and RT resistance(ideal).

$$R_{RT} = \frac{15000}{f_{SW} \times 10^{-3}} \quad [k\Omega]$$

where:

$R_{RT}$  is the external resistance of RT.  
 $f_{SW}$  is DC/DC switching frequency.

Oscillation setting ranges 50kHz to 2000kHz.

Setting example is separately described in the section "[DC/DC Oscillation Frequency Setting](#)".

### Pin 6: DUTYON

This is the ON/OFF setting pin of the LED PWM Over Duty Protection(ODP).  
By adjusting DUTYON input voltage, ON/OFF of the ODP is adjusted.

State	DUTYON Input Voltage
ODP=ON	$V_{DUTYON\_L} = -0.3V$ to $+0.8V$
ODP=OFF	$V_{DUTYON\_H} = 1.5V$ to $18.0V$

And this is FAIL signal output(OPEN DRAIN) pin. At normal operation, PMOS will be OPEN state. During abnormality detection PMOS will be in ON state and this pin is pulled up to the REG90 pin by 3.4kΩ.

## Description of Pin Function - continued

**Pin 7: PWM**

This is the PWM dimming signal input pin. High/Low level of PWM are the following.

State	PWM Input Voltage
PWM=H	$V_{PWM\_H}=1.5V$ to $18.0V$
PWM=L	$V_{PWM\_L}=-0.3V$ to $+0.8V$

Do not input the pulse with Low section less than following values into the PWM pin at ODP function ON.

$$t_{PWML\_MIN} = \frac{R_{DUTYP} \times 10^{-3}}{15} < t_{PWML} \quad [\mu s]$$

where:

$t_{PWML\_MIN}$  is the narrowest width of available PWM=L.

$R_{DUTYP}$  is the external resistance of DUTYP.

$t_{PWML}$  is Low section of PWM.

**Pin 8: DUTYP**

This is the ODP setting pin. ODP(Over Duty Protection) is the function to limit duty of LED PWM by ODP detection duty( $ODP_{DUTY}$ ) set by resistance( $R_{DUTYP}$ ) connected to DUTYP.

○ **Relation between LED PWM frequency  $f_{PWM}$ , ODP Detection Duty and DUTYP resistance(ideal)**

$$R_{DUTYP} = \frac{1172 \times ODP_{DUTY}}{f_{PWM}} \quad [k\Omega]$$

where:

$R_{DUTYP}$  is the external resistance of DUTYP.

$ODP_{DUTY}$  is ODP detection duty.

$f_{PWM}$  is PWM frequency.

$R_{DUTYP}$  setting ranges 15k $\Omega$  to 600k $\Omega$ .

Setting example is separately described in the section "[ODP Setting](#)".

**Pin 9: SSFB**

This is the pin which sets the soft start interval of DC/DC converter and the output pin of error amplifier. It performs the constant current charge of 10.0 $\mu A$  to external capacitance  $C_{SSFB}$ , works as a soft start of DC/DC. When  $C_{SSFB} \leq 1nF$ , be careful if the in-rush current during startup is too large, or if over boost detection(FBMAX) mask timing is too short. It makes the following action after soft start completion( $V_{SSFB} \geq 3.7V$ ). When PWM=H, it compares ISENSE voltage to analog dimming voltage(ADIM) and outputs error signal. When PWM=L, it holds  $V_{SSFB}$  at the edge of PWM=H to L, and operates to hold the adjacent voltage. It detects over boost(FBMAX). If  $V_{SSFB} \geq 4.0V$  and PWM=H continue to count 4 GATE clks, the CP counter starts. After that, only  $V_{SSFB} \geq 4.0V$  is monitored, When CP counter reaches 2048 clk( $2^{11}$  clk), IC will be latched off.

(Refer to section "[Timing Chart FBMAX Detection](#)".)

The loop compensation setting is described in section "[Loop Compensation](#)".

Description of Pin Function - continued

Pin 10: ISENSE

This is the input pin for the current sensing. Error amplifier compares the lower one among 1/2 of  $V_{ADIM}$  and 1.515V. And it detects abnormal LED over current at  $V_{ISENSE} \geq 3.0V$ . If the GATE pin continues to count 4 GATE clks, it becomes latch-off. (Refer to section ["Timing Chart LED OCP Detection"](#).)

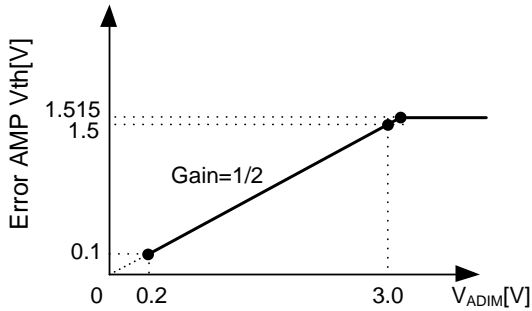

Figure 1. Relation of the Feedback Voltage and  $V_{ADIM}$

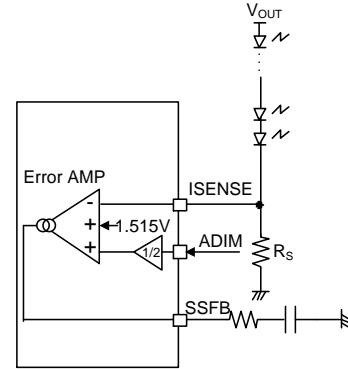

Figure 2. The ISENSE Pin Circuit Example

Pin 11: GND

This is the GND pin of the IC.

Pin 12: GATE

This is the output pin for driving the gate of the boost MOSFET. The high level is REG90. Frequency can be set by resistor connected to the RT pin. Refer to ["DC/DC Oscillation Frequency Setting"](#), for pin description for the frequency setting.

Pin 13: CS

The CS pin has two functions.

(1) DC/DC Current Mode Feedback Pin

The inductor current is converted to the CS pin voltage by the sense resistor  $R_{CS}$ . This voltage compared to the voltage set by error amplifier controls the output pulse.

(2) Inductor Current Limit(OCP) Pin

The CS pin also has an over current protection(OCP). If  $V_{CS} \geq 0.4V$ , the switching operation will be stopped compulsorily. And the next boost pulse will be restarted to normal frequency. In addition, if  $V_{CS} \geq 1.0V$  continues to count 4 GATE clks, IC will be latch off. As above OCP operation, if the current continues to flow nevertheless GATE=L because of the destruction of the boost MOS, IC will stop the operation completely.

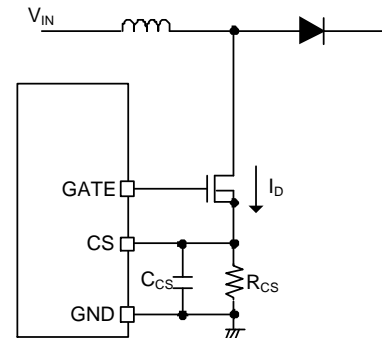

Figure 3. The CS Pin Circuit Example

Both of the above functions are enabled after 300ns when the GATE pin asserts high, because the Leading Edge Blanking function(LEB) is included into this IC to prevent the effect of noise. Refer to section ["OCP Setting/Calculation Method for the Current Rating of DC/DC Parts"](#), for detailed explanation. If  $C_{CS}$  is micro order, be careful that the limited value of NMOS drain current  $I_D$  is more than the simple calculation. Because the current  $I_D$  flows not only through  $R_{CS}$  but also through  $C_{CS}$ , as the CS pin voltage moves according to  $I_D$ .

Pin 14: REG90

This is the 9.0V output pin. Max source current is 15mA(Min). VCC must be used in 10.5V or more for stable 9V output. Place the ceramic capacitor connected to REG90 pin(1.0 $\mu$ F to 10 $\mu$ F) closest to REG90-GND pin.

## Absolute Maximum Ratings (Ta=25°C)

Parameter	Symbol	Rating	Unit
Power Supply Voltage	V <sub>CC</sub>	-0.3 to +36	V
SFTON, RT, DUTYP, SSFB, ISENSE, CS Pin Voltage	V <sub>SFTON</sub> , V <sub>RT</sub> , V <sub>DUTYP</sub> , V <sub>SSFB</sub> , V <sub>ISENSE</sub> , V <sub>CS</sub>	-0.3 to +7	V
REG90 Pin Voltage	V <sub>REG90</sub>	-0.3 to +13	V
GATE Pin Voltage	V <sub>GATE</sub>	-0.3 to +15	V
OVP, ADIM, DUTYON, PWM Pin Voltage	V <sub>OVP</sub> , V <sub>ADIM</sub> , V <sub>DUTYON</sub> , V <sub>PWM</sub>	-0.3 ~ +20	V
Maximum Junction Temperature	T <sub>jmax</sub>	150	°C
Storage Temperature Range	T <sub>stg</sub>	- 55 to + 150	°C

**Caution 1:** Operating the IC over the absolute maximum ratings may damage the IC. The damage can either be a short circuit between pins or an open circuit between pins and the internal circuitry. Therefore, it is important to consider circuit protection measures, such as adding a fuse, in case the IC is operated over the absolute maximum ratings.

**Caution 2:** Should by any chance the maximum junction temperature rating be exceeded the rise in temperature of the chip may result in deterioration of the properties of the chip. In case of exceeding this absolute maximum rating, design a PCB boards with thermal resistance taken into consideration by increasing board size and copper area so as not to exceed the maximum junction temperature rating.

Thermal Resistance<sup>(Note 1)</sup>

Parameter	Symbol	Thermal Resistance (Typ)		Unit
		1s <sup>(Note 3)</sup>	2s2p <sup>(Note 4)</sup>	
SSOP-B14				
Junction to Ambient	θ <sub>JA</sub>	159.6	92.8	°C/W
Junction to Top Characterization Parameter <sup>(Note 2)</sup>	Ψ <sub>JT</sub>	13	9	°C/W

(Note 1) Based on JESD51-2A(Still-Air).

(Note 2) The thermal characterization parameter to report the difference between junction temperature and the temperature at the top center of the outside surface of the component package.

(Note 3) Using a PCB board based on JESD51-3.

(Note 4) Using a PCB board based on JESD51-7.

Layer Number of Measurement Board	Material	Board Size
Single	FR-4	114.3mm x 76.2mm x 1.57mmt

Top	
Copper Pattern	Thickness
Footprints and Traces	70μm

Layer Number of Measurement Board	Material	Board Size
4 Layers	FR-4	114.3mm x 76.2mm x 1.6mmt

Top		2 Internal Layers		Bottom	
Copper Pattern	Thickness	Copper Pattern	Thickness	Copper Pattern	Thickness
Footprints and Traces	70μm	74.2mm x 74.2mm	35μm	74.2mm x 74.2mm	70μm

## Recommended Operating Conditions

Parameter	Symbol	Min	Typ	Max	Unit
Operating Temperature	Topr	-40	+25	+105	°C
Power Supply Voltage	V <sub>CC</sub>	9.0	24.0	35.0	V
DC/DC Oscillation Frequency	f <sub>SW</sub>	50	150	2000	kHz
Effective Range of ADIM Signal	V <sub>ADIM</sub>	0.2	2.0	3.0	V
PWM Input Frequency	f <sub>PWM</sub>	90	120	2000	Hz
REG90 Pin External Capacitance <sup>(Note 5)</sup>	C <sub>REG90</sub>	1.0	2.2	10.0	μF
SFTON Pin External Capacitance	C <sub>SFTON</sub>	100	470	1000	pF

(Note 5) There are the characteristic parts that effective capacitance value largely becomes small when the DC voltage is applied, and be careful because output voltage may oscillate.



Electrical Characteristics (Unless otherwise specified  $V_{CC}=24V$   $T_a=25^{\circ}C$ )

Parameter	Symbol	Min	Typ	Max	Unit	Conditions
<b>Total Current Consumption</b>						
Circuit Current	$I_{CC}$	-	3	6	mA	$V_{PWM}=3.0V$
<b>UVLO</b>						
Operation Voltage(VCC)	$V_{UVLO\_VCC}$	6.5	7.5	8.5	V	$V_{CC}=\text{Sweep Up}$
Hysteresis Voltage(VCC)	$V_{UHYS\_VCC}$	150	300	600	mV	$V_{CC}=\text{Sweep Down}$
<b>DC/DC</b>						
ISENSE Threshold Voltage 1	$V_{LED1}$	0.346	0.350	0.354	V	$V_{ADIM}=0.7V$
ISENSE Threshold Voltage 2	$V_{LED2}$	0.992	1.000	1.008	V	$V_{ADIM}=2.0V$
ISENSE Threshold Voltage 3	$V_{LED3}$	1.489	1.500	1.511	V	$V_{ADIM}=3.0V$
ISENSE Clamp Voltage	$V_{LED4}$	1.497	1.515	1.533	V	$V_{ADIM}=3.3V$ (as Masking Analog Dimming)
Oscillation Frequency	$f_{SW}$	142.5	150	157.5	kHz	$R_{RT}=100k\Omega$
RT Short Protection Range	$V_{RT\_DET}$	-0.3	-	$V_{RT\_1}$ $\times 90\%$	V	$V_{RT}=\text{Sweep Down}$
RT Pin Voltage	$V_{RT\_1}$	-	2.0	-	V	$R_{RT}=100k\Omega$
GATE Pin MAX Duty Output	$D_{MAX\_DUTY}$	90	95	99	%	$R_{RT}=100k\Omega$
GATE Pin ON Resistance (as source)	$R_{ON\_GSO}$	2.5	5.0	10.0	$\Omega$	
GATE Pin ON Resistance (as sink)	$R_{ON\_GSI}$	2.0	4.0	8.0	$\Omega$	
SFTON Pin Source Current	$I_{SFTSO}$	-37.5	-30.0	-22.5	$\mu A$	$V_{PWM}=3.0V$
SFTON Pin Discharge Resistance	$R_{SFTDIS}$	-	1.5	2.5	k $\Omega$	
SSFB Source Current(at Soft Start)	$I_{SSSO}$	-13.0	-10.0	-7.0	$\mu A$	$V_{SSFB}=2.0V$
SSFB Source Current	$I_{SSFBSO}$	-115	-100	-85	$\mu A$	$V_{ISENSE}=0.2V$ , $V_{ADIM}=3.0V$ , $V_{SSFB}=1.0V$
SSFB Sink Current	$I_{SSFBSI}$	85	100	115	$\mu A$	$V_{ISENSE}=2.0V$ , $V_{ADIM}=3.0V$ , $V_{SSFB}=1.0V$

Electrical Characteristics - continued (Unless otherwise specified V<sub>CC</sub>=24V Ta=25°C)

Parameter	Symbol	Min	Typ	Max	Unit	Conditions
<b>DC/DC Protection</b>						
OCP Detect Voltage	V <sub>OCP</sub>	360	400	440	mV	V <sub>CS</sub> =Sweep Up
OCP Latch Off Detect Voltage	V <sub>OCP OFF</sub>	0.85	1.00	1.15	V	V <sub>CS</sub> =Sweep Up
OVP Detect Voltage	V <sub>OVP_DET</sub>	2.88	3.00	3.12	V	V <sub>OVP</sub> =Sweep Up
OVP Detect Hysteresis	V <sub>OVP_HYS</sub>	150	200	250	mV	V <sub>OVP</sub> =Sweep Down
OVP Pin Leak Current	I <sub>OVP_LK</sub>	-2	0	+2	μA	V <sub>OVP</sub> =4.0V
<b>LED Protection Block</b>						
LED OCP Detect Voltage	V <sub>LEDOCP</sub>	2.88	3.00	3.12	V	V <sub>ISENSE</sub> =Sweep Up
Over Boost Detection Voltage	V <sub>FBMAX</sub>	3.84	4.00	4.16	V	V <sub>SSFB</sub> =Sweep Up
<b>Dimming</b>						
ADIM Pin Leak Current	I <sub>ADIM_LK</sub>	-2	0	+2	μA	V <sub>ADIM</sub> =2.0V
ISENSE Pin Leak Current	I <sub>ISENSE_LK</sub>	-2	0	+2	μA	V <sub>ISENSE</sub> =4.0V
<b>REG90</b>						
REG90 Output Voltage 1	V <sub>REG90_1</sub>	8.955	9.000	9.045	V	I <sub>REG90</sub> =0mA
REG90 Output Voltage 2	V <sub>REG90_2</sub>	8.910	9.000	9.090	V	I <sub>REG90</sub> =-15mA
REG90 Max Source Current	I <sub>REG90_SOM AX</sub>	15	-	-	mA	
REG90_UVLO Detect Voltage	V <sub>REG90_UV DET</sub>	5.22	6.00	6.78	V	V <sub>REG90</sub> =Sweep Down
<b>PWM</b>						
PWM Pin H Voltage	V <sub>PWM_H</sub>	1.5	-	18	V	
PWM Pin L Voltage	V <sub>PWM_L</sub>	-0.3	-	+0.8	V	
PWM Pin Pull Down Resistance	R <sub>PWM</sub>	600	1000	1400	kΩ	V <sub>PWM</sub> =3.0V
<b>DUTYON</b>						
DUTYON Pin H Voltage	V <sub>DUTYON_H</sub>	1.5	-	18	V	
DUTYON Pin L Voltage	V <sub>DUTYON_L</sub>	-0.3	-	+0.8	V	
DUTYON Pin Pull Down Resistance	R <sub>DUTYON</sub>	600	1000	1400	kΩ	V <sub>DUTYON</sub> =3.0V
<b>Over Duty Protection</b>						
PWM ODP Protection Detect Duty	D <sub>ODP</sub>	-	35	-	%	f <sub>PWM</sub> =120Hz, R <sub>DUTYP</sub> =341kΩ
DUTYP Short Protection Range	V <sub>DUTYP_DET</sub>	-0.3	-	V <sub>DUTYP_1</sub> x 90%	V	V <sub>DUTYP</sub> =Sweep Down
DUTYP Pin Voltage	V <sub>DUTYP_1</sub>	-	2.0	-	V	R <sub>DUTYP</sub> =100kΩ
<b>Timer</b>						
Abnormal Detection Time	t <sub>LATCH</sub>	-	2.5	-	ms	f <sub>SW</sub> =800kHz
Auto-Restart Time	t <sub>AUTO</sub>	-	163	-	ms	f <sub>SW</sub> =800kHz

Typical Performance Curves  
(Reference Characteristic)

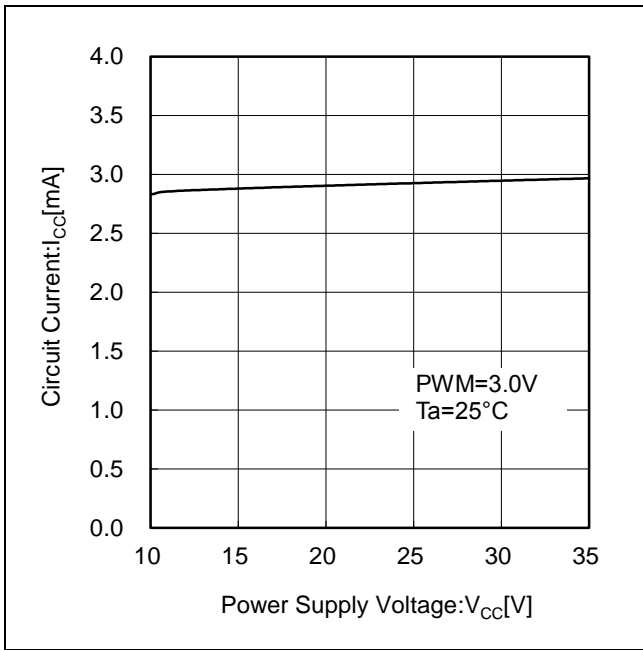

Figure 4. Circuit Current vs Power Supply Voltage

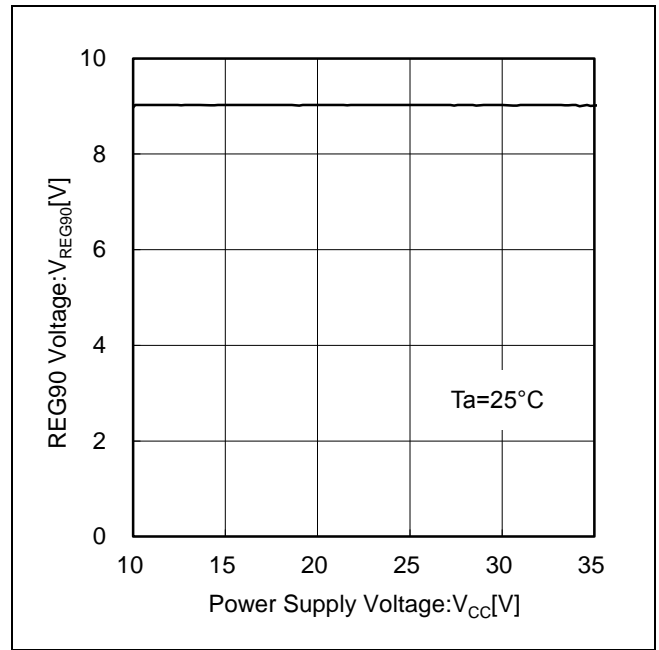

Figure 5. REG90 Voltage vs Power Supply Voltage

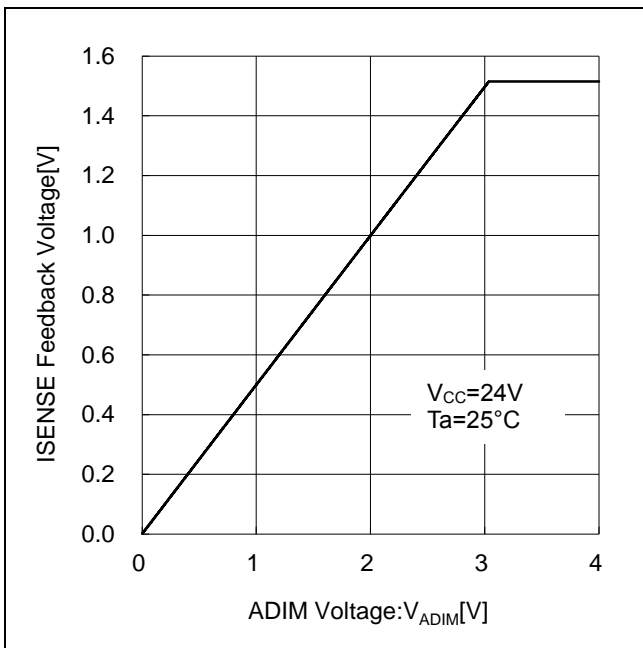

Figure 6. ISENSE Feedback Voltage vs ADIM Voltage

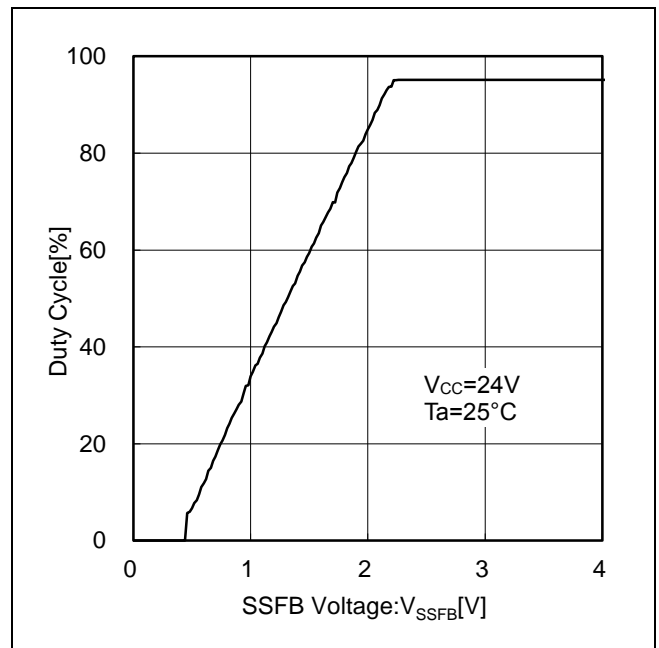

Figure 7. Duty Cycle vs SSFB Voltage

### List of Protection Detection Condition

If there is no description, the mentioned values are typical value.

Protect Function	Detection Pin	Detect Condition		Release Condition	Timer Operation	Protection Type
		Detection Condition	PWM			
FBMAX	SSFB	$V_{SSFB} \geq 4.0V$	H(4clk)	$V_{SSFB} < 4.0V$	2 <sup>11</sup> clk	Auto-Restart (Judge Periodically whether Normal or Not)
LED OCP	ISENSE	$V_{ISENSE} \geq 3.0V$	-	$V_{ISENSE} < 3.0V$	4clk	Auto-Restart (Judge Periodically whether Normal or Not)
RT GND Short	RT	$V_{RT} < V_{RT\_1} \times 90\%$	-	Release RT=GND	NO	Restart by Release
RT High Short	RT	$V_{RT} \geq 5.0V$	-	Release RT=H	NO	Restart by Release
REG90 UVLO	REG90	$V_{REG90} < 6.0V$	-	$V_{REG90} \geq 6.5V$	NO	Restart by Release
VCC UVLO	VCC	$V_{CC} < 7.2V$	-	$V_{CC} \geq 7.5V$	NO	Restart by Release
OVP	OVP	$V_{OVP} \geq 3.0V$	-	$V_{OVP} < 2.8V$	4clk	Auto-Restart (Judge Periodically whether Normal or Not)
OCP	CS	$V_{CS} \geq 0.4V$	-	-	NO	Pulse by Pulse
OCP LATCH	CS	$V_{CS} \geq 1.0V$	-	$V_{CS} < 1.0V$	4clk	Auto-Restart (Judge Periodically whether Normal or Not)
DUTYP GND Short	DUTYP	$V_{DUTYP} < V_{DUTYP\_1} \times 90\%$	-	Release DUTYP=GND	NO	Restart by Release
DUTYP High Short	DUTYP	$V_{DUTYP} \geq 5.0V$	-	Release DUTYP=H	NO	Restart by Release
ODP <i>(Note 1)</i>	PWM	DUTYON=H and PWM On Duty > Setting Duty by DUTYP Resistor	H	-	NO	Cycle by Cycle

The clk number of the list corresponds to the oscillation frequency of DC/DC.

*(Note 1)* When PWM=L → H is input, PWM duty count start. When PWM=H → L is input, the count is reset. The GATE output maintain Low until PWM=H → L is inputted again in PWM = 100% when ODP works once.

### List of Protection Function Operation

Protect Function	Operation of the Protect Function			
	DC/DC Gate Output	SSFB Pin	SFTON Pin	PMOS of DUTYON Pin
FBMAX	Stop after timer operation	Discharge after timer operation	Discharge after timer operation	ON after timer operation
LED OCP	Stop Immediately	Discharge after timer operation	Discharge after timer operation	ON after timer operation
RT GND Short	Stop Immediately	Not Discharge	Not Discharge	OPEN
RT High Short	Stop Immediately	Not Discharge	Not Discharge	OPEN
REG90 UVLO	Stop Immediately	Discharge Immediately	Discharge Immediately	OPEN
VCC UVLO	Stop Immediately	Discharge Immediately	Discharge Immediately	OPEN
OVP	Stop Immediately	Discharge after timer operation	Discharge after timer operation	ON after timer operation
OCP	Stop Immediately	Not Discharge	Not Discharge	OPEN
OCP LATCH	Stop after timer operation	Discharge after timer operation	Discharge after timer operation	ON after timer operation
DUTYP GND Short	Stop Immediately	Not Discharge	Not Discharge	OPEN
DUTYP High Short	Stop Immediately	Not Discharge	Not Discharge	OPEN
ODP	Immediately Low	Not Discharge	Not Discharge	OPEN

Refer to section "[Timing Chart](#)" for details.

## Timing Chart

If there is no description, the mentioned values are typical value.

## 1 PWM Start-up

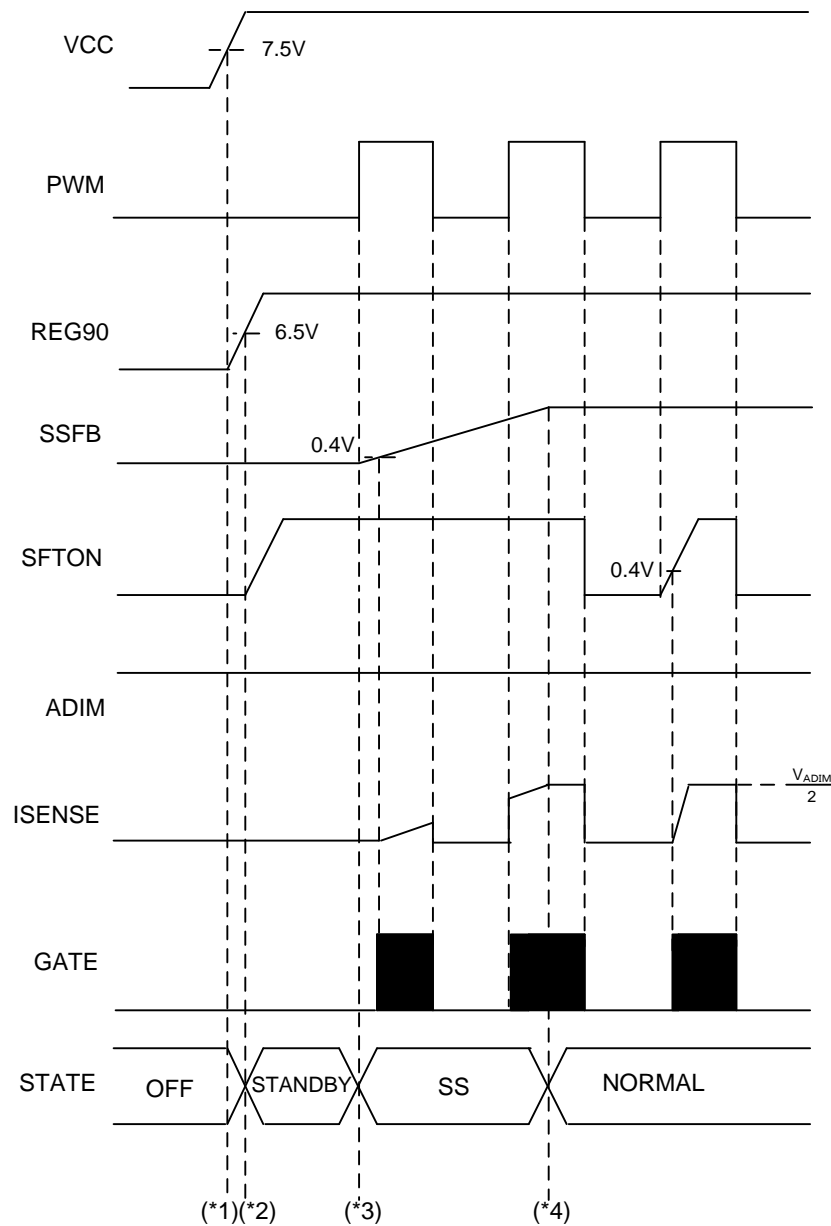

Figure 8. PWM Start Up

- (\*1) REG90 starts up when VCC reaches 7.5V. In the state where the PWM signal is not inputted, the SSFB pin is not charged and DC/DC does not start to boost, either.
- (\*2) When REG90 is 6.5V or more, the reset signal is released.
- (\*3) The charge of the SS pin starts at the positive edge of PWM=L to H, and the soft start starts. And while  $V_{SSFB}$  or  $V_{SFTON}$  is less than 0.4V, the GATE pulse does not output. The SSFB pin continues charging regardless of PWM and OVP level.
- (\*4) The soft start interval will end if  $V_{ISENSE}$  reaches  $V_{ADIM}/2$ . At this time,  $V_{OUT}$ (LED anode voltage) reaches the voltage which the setting LED electric current flows in.

Timing Chart - continued

2 Turn Off

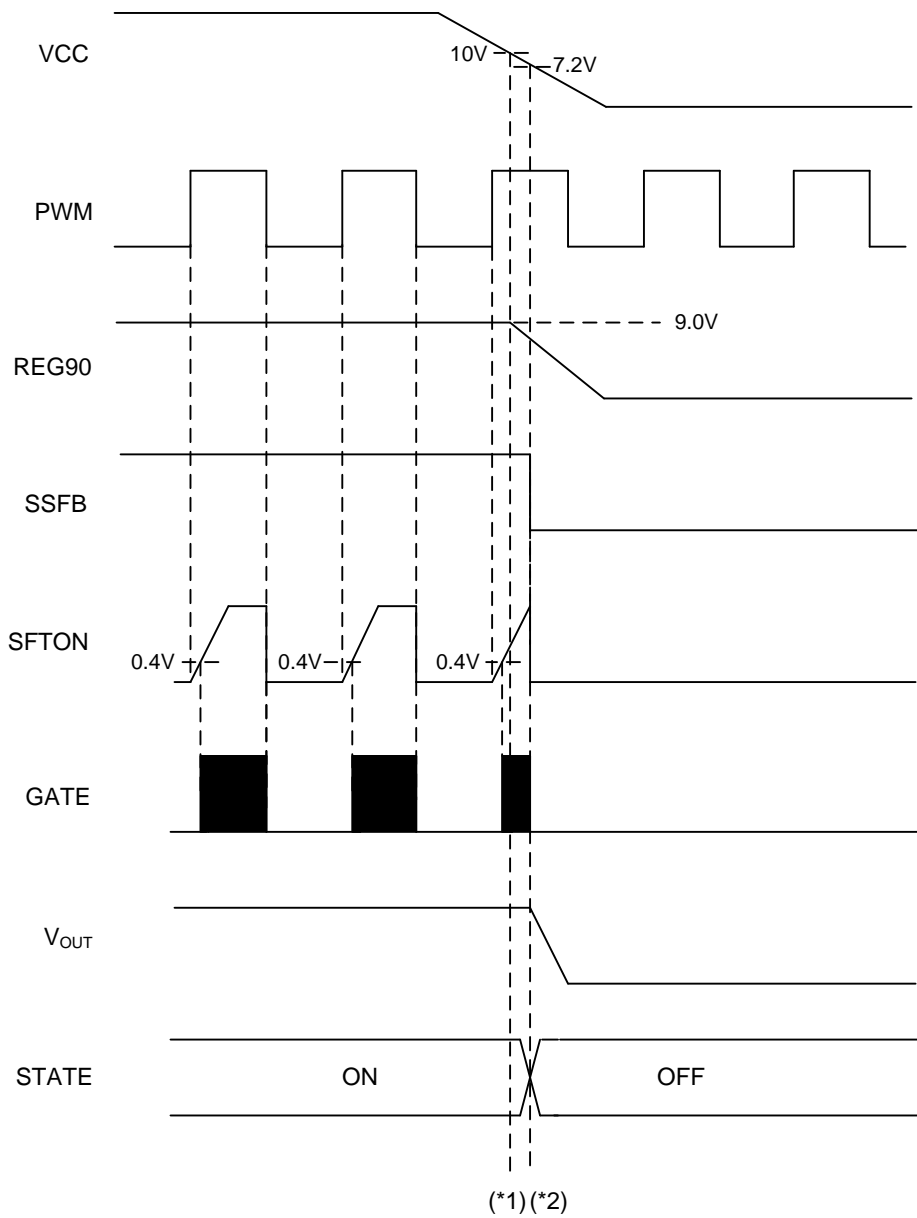

Figure 9. Turn Off

(\*1)When  $V_{CC} < 10.0V$ , IC cannot keep  $V_{REG90} = 9V$ .

(\*2)When  $V_{CC} < 7.2V$ , boost operation stops and IC becomes OFF.

## Timing Chart - continued

## 3 Soft Start Function

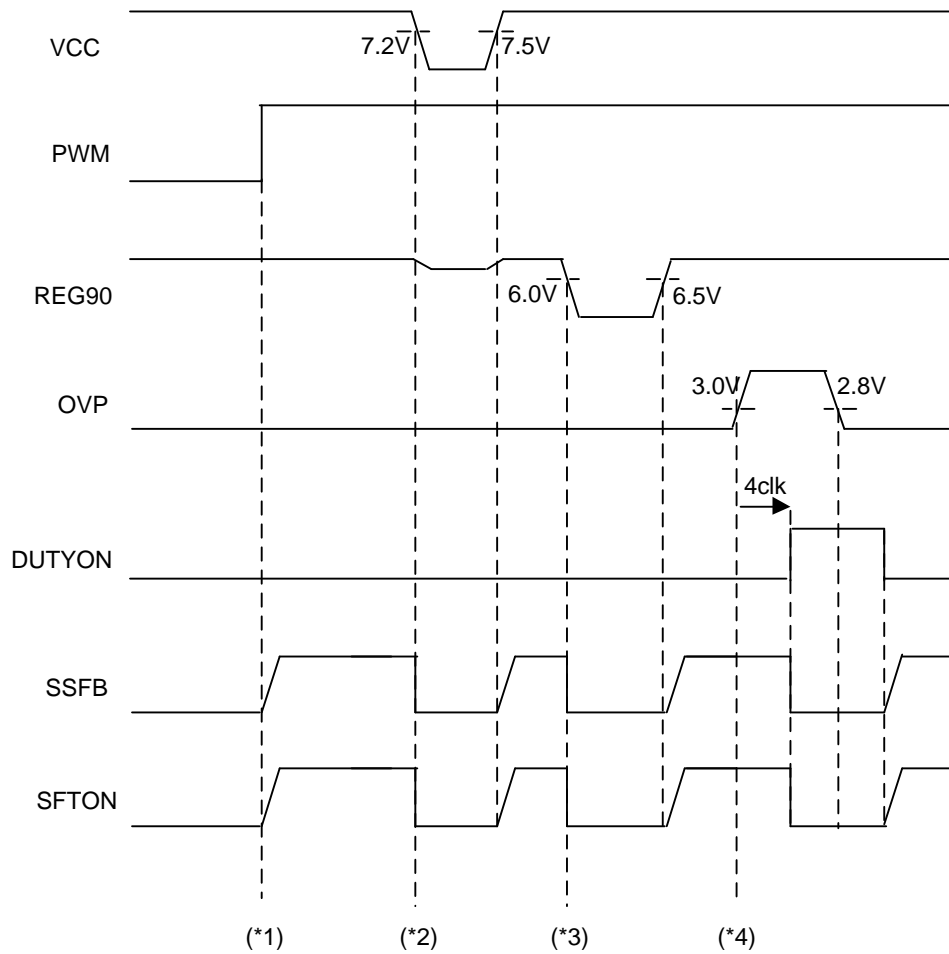

Figure 10. Soft Start Function

- (\*1) The SSFB and SFTON pin charge do not start by just  $V_{CC}=7.5V$ . PWM=H is required to start the soft start. In the low SSFB or SFTON voltage, the GATE pin duty depends on the SSFB or SFTON voltage. And while the SSFB or SFTON is less than 0.4V, the pulse does not output.
- (\*2) When  $V_{CC} < 7.2V$ , the SSFB and SFTON pin are discharged.
- (\*3) When  $V_{REG90} < 6.0V$ , the SSFB and SFTON pin are discharged.
- (\*4) The SSFB and SFTON pin are not discharged by the abnormal detection of the latch off type such as OVP until the latch off.

## Timing Chart - continued

## 4 OVP Detection

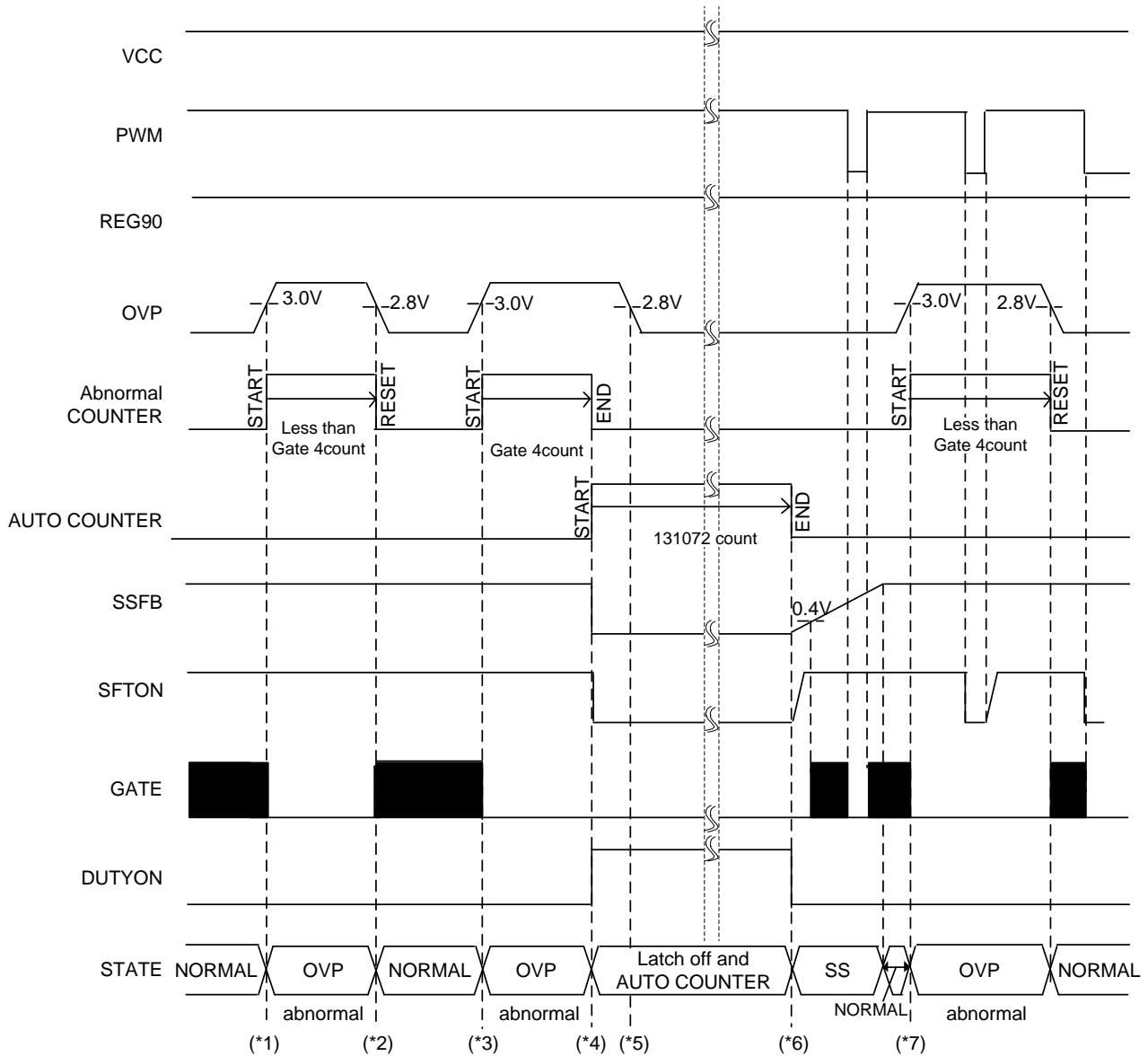

Figure 11. OVP Detection

- (\*1) As OVP is detected, the output GATE=L and the abnormal counter starts.
- (\*2) If OVP is released less than 4 GATE clks, the boost operation restarts.
- (\*3) As the OVP is detected again, the boost operation is stopped.
- (\*4) As the OVP detection continues to count 4 GATE clks, IC will be latched off. After latched off, auto counter starts counting.
- (\*5) Once IC is latched off, the boost operation does not restart even if OVP is released.
- (\*6) When auto counter reaches  $131072\text{clk}(2^{17}\text{clk})$ , IC will be auto-restarted. The auto-restart interval can be calculated by the external resistor of the RT pin. (Refer to the section "[Abnormal Detection Time and Auto-Restart Time Setting](#)".)
- (\*7) The operation of the OVP detection is not related to the logic of PWM.



## Timing Chart - continued

## 5 FBMAX Detection

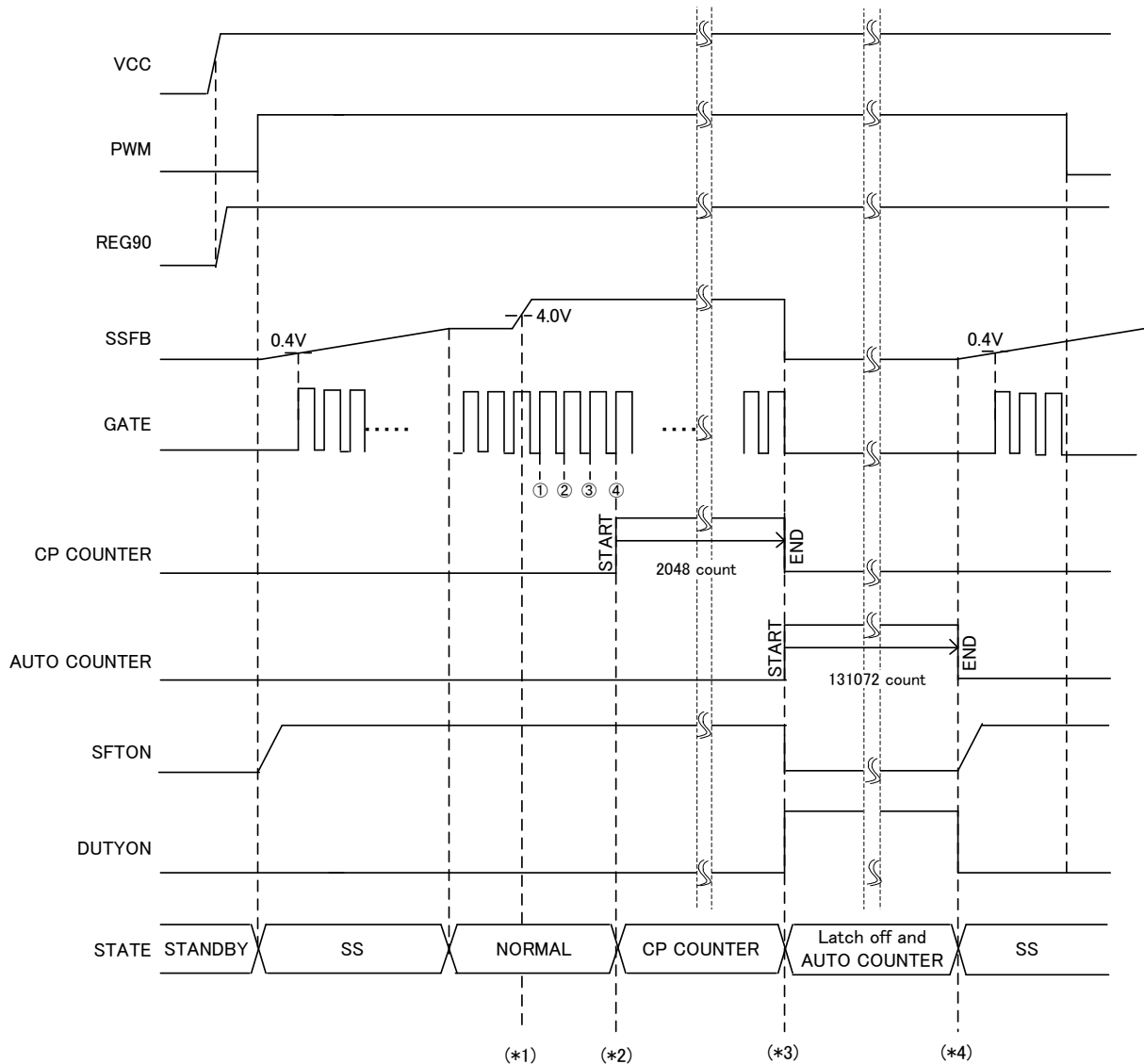

Figure 12. FBMAX Detection

- (\*1) When the PWM=H and SSFB=H ( $V_{SSFB} \geq 4.0V$ ), the abnormal counter does not start immediately.
- (\*2) The CP counter will start if the PWM=H and the SSFB=H detection continues up to 4 clks of the GATE frequency. Once the count starts, only SSFB level is monitored.
- (\*3) When the FBMAX detection continues till the CP counter reaches 2048 clks ( $2^{11}$  clks), IC will be latched off. The latch off interval can be calculated by the external resistor of the RT pin. (Refer to the section "[Abnormal Detection Time and Auto-Restart Time Setting](#)".)
- (\*4) When auto counter reaches 131072 clks ( $2^{17}$  clks), IC will be auto-restarted. The auto-restart interval can be calculated by the external resistor of the RT pin. (Refer to the section "[Abnormal Detection Time and Auto-Restart Time Setting](#)".)

## Timing Chart - continued

## 6 LED OCP Detection

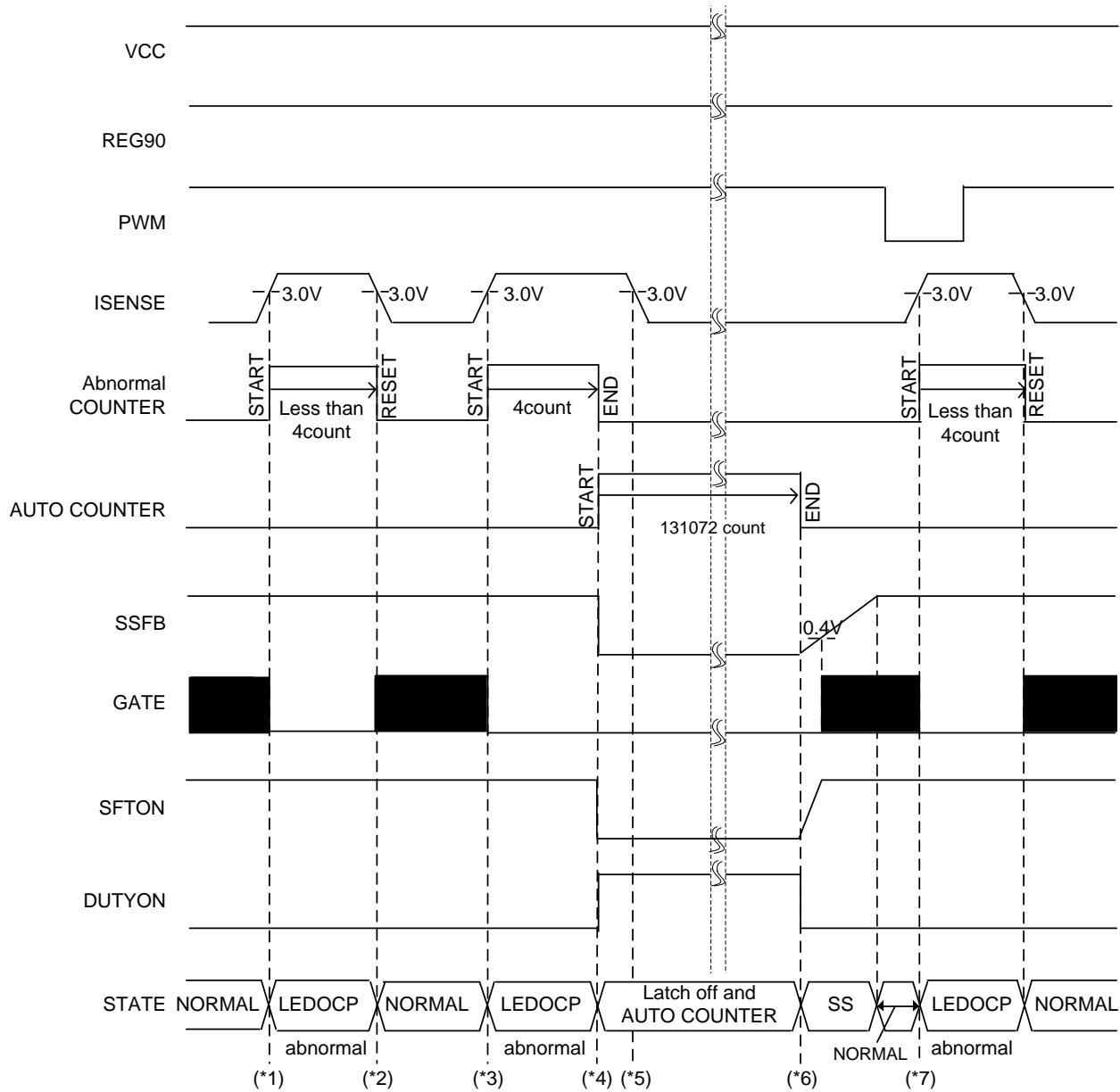

Figure 13. LED OCP Detection

- (\*1) If  $V_{ISENSE} \geq 3.0V$  and LED OCP is detected, GATE becomes Low.
- (\*2) If LED OCP is released within 4 GATE clks, the boost operation restarts.
- (\*3) As the LED OCP is detected again, the boost operation is stopped.
- (\*4) If the LED OCP detection continues to count 4 GATE clks, IC will be latched off. After latched off, auto counter starts counting.
- (\*5) Once IC is latched off, the boost operation does not restart even if the LED OCP releases.
- (\*6) When auto counter reaches 131072 clks ( $2^{17}$  clks), IC will be auto-restarted. The auto-restart interval can be calculated by the external resistor of the RT pin. (Refer to the section "[Abnormal Detection Time and Auto-Restart Time Setting Timer Latch Time Setting](#)".)
- (\*7) The operation of the LED OCP detection is not related to the logic of the PWM.

Application Examples

Introduce an example application using the BD9408FV.

1 Basic Application Example

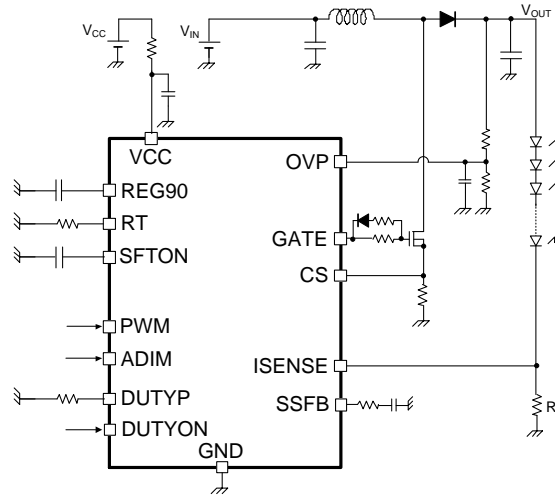

Figure 14. Basic Application Example

2 Analog Dimming or PWM Dimming Examples

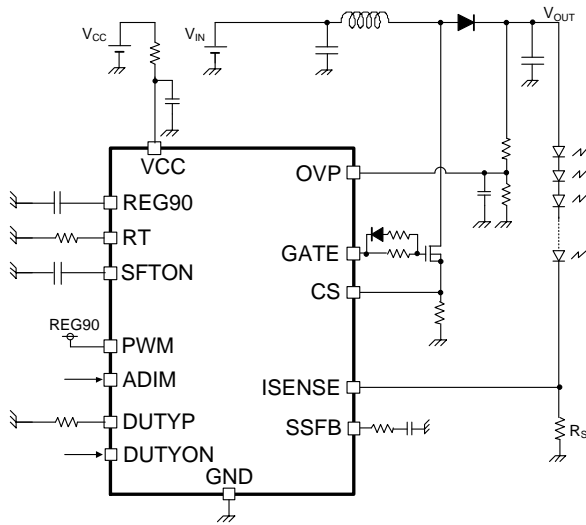

Figure 15. Example Circuit for Analog Dimming

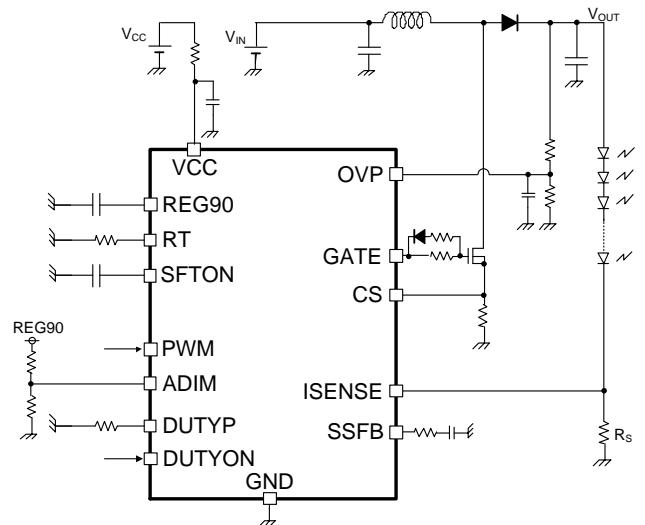

Figure 16. Example Circuit for PWM Dimming

## Selection of Components Externally Connected

If there is no description, the mentioned values are typical value.

### 1 Start Up Operation and Soft Start External Capacitance Setting

The below explanation is the startup sequence of this IC.

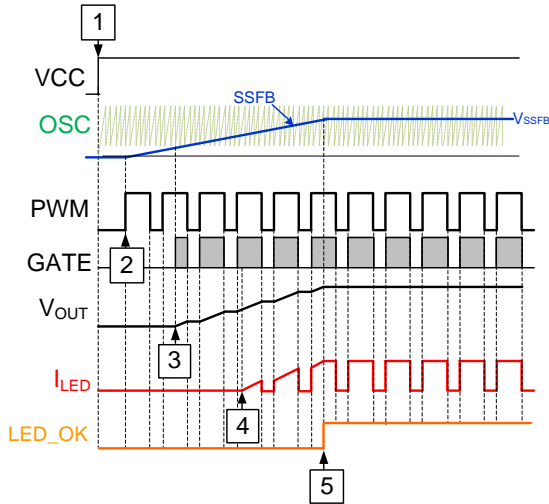

Figure 17. Start Up Waveform

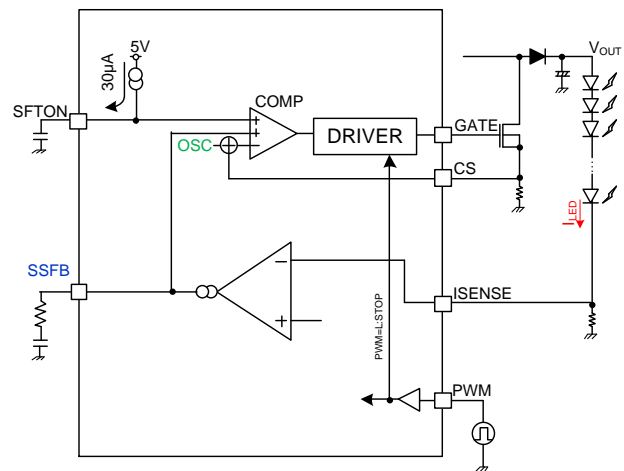

Figure 18. Circuit Behavior at Startup

#### (1) Explanation of start up sequence

1. Reference voltage REG90 starts by  $V_{CC}=7.5V$ .
2. SSFB starts to charge at the time of first PWM=H.
3. When SSFB reaches the lower point of internal sawtooth waveform, the GATE pin outputs pulse and starts to boost  $V_{OUT}$ .
4. It boosts  $V_{OUT}$  and  $V_{OUT}$  reaches the voltage to be able to flow LED current.
5. If LED current flows the decided level or more, start up behavior completes.

#### (2) Method of setting SSFB external capacitance

According to the sequence described above, start time  $t_{SSFB}$  is the time that LED current flows the decided level or more. The equality on  $t_{SSFB}$  is as follows.

$$t_{SSFB} = \frac{C_{SSFB} \times V_{SSFB}}{I_{SSFB}} \quad [s]$$

where:

$t_{SSFB}$  is start time.

$C_{SSFB}$  is the external capacitance of the SSFB pin.

$V_{SSFB}$  is the SSFB pin voltage.

$I_{SSFB}$  is SSFB source current.

If  $C_{SSFB}$  is set to very small value, rush current flows into the inductor at startup. On the contrary, if  $C_{SSFB}$  is enlarged too much, LED will light up gradually. Since  $C_{SSFB}$  differs in the constant set up with the characteristic searched for and differs also by factors, such as a voltage rise ratio, an output capacitance, DC/DC frequency and LED current, confirm with the actual device.

#### [Setting Example]

When  $C_{SSFB}=0.1\mu F$ ,  $V_{SSFB}=3.7V$ ,  $I_{SSFB}=10\mu A$ ,  $t_{SSFB}$  is as follows.

$$t_{SSFB} = \frac{0.1 \times 10^{-6} \times 3.7}{10 \times 10^{-6}} = 0.037 \quad [s]$$

Selection of Components Externally Connected - continued

2 SFTON External Capacitance Setting

It sets the soft start time for LED electric current at PWM=L to PWM=H. It performs the constant current charge of 30.0μA to external capacitance C<sub>SFTON</sub>. The switching duty of GATE output will be limited during 0V to SSFB voltage of SFTON voltage. So the soft on interval t<sub>SFTON</sub> can be expressed as follows.

$$t_{SFTON} = \frac{C_{SFTON} \times V_{SSFB}}{30 \times 10^{-6}} \quad [s]$$

where:

- t<sub>SFTON</sub> is the operation period of soft on.
- C<sub>SFTON</sub> is the external capacitance of the SFTON pin.
- V<sub>SSFB</sub> is the SSFB pin voltage.

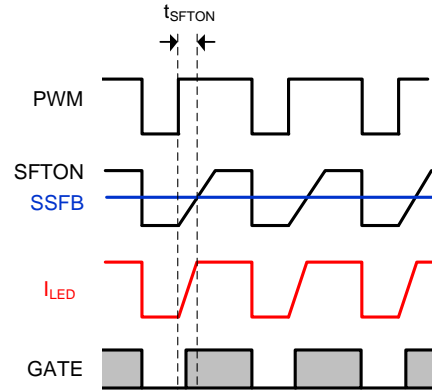

Figure 19. Soft ON Function

[Setting Example]

When C<sub>SFTON</sub>=1000pF, V<sub>SSFB</sub>=3V, soft on time is as follows.

$$t_{SFTON} = \frac{1000 \times 10^{-12} \times 3}{30 \times 10^{-6}} = 100 \times 10^{-6} \quad [s]$$

3 VCC Series Resistance Setting

Here are the following effects of inserting series resistor R<sub>VCC</sub> into VCC line.

- (1) In order to drop the voltage VCC, it is possible to suppress the heat generation of the IC.
- (2) It can limit the inflow current to VCC line. However, if resistance R<sub>VCC</sub> is set bigger, VCC voltage becomes under minimum operation voltage (V<sub>CC</sub> < 9V). R<sub>VCC</sub> must be set to an appropriate series resistance.

IC's inflow current line I<sub>IN</sub> has the following inflow lines.

- IC's circuit current...I<sub>CC</sub>
  - Current to DC/DC DRIVER...I<sub>DCDC</sub>
  - Current of R<sub>REG</sub> connected to REG90...I<sub>REG</sub>
- These decide the voltage ΔV at R<sub>VCC</sub>.

VCC pin voltage at that time can be expressed as follows.

$$V_{CC} = V_{IN} - (I_{CC} + I_{DCDC} + I_{REG}) \times R_{VCC} \geq 9 \quad [V]$$

Here, judgment is the 9V minimum operation voltage. Consider a sufficient margin when setting the series resistor of VCC.

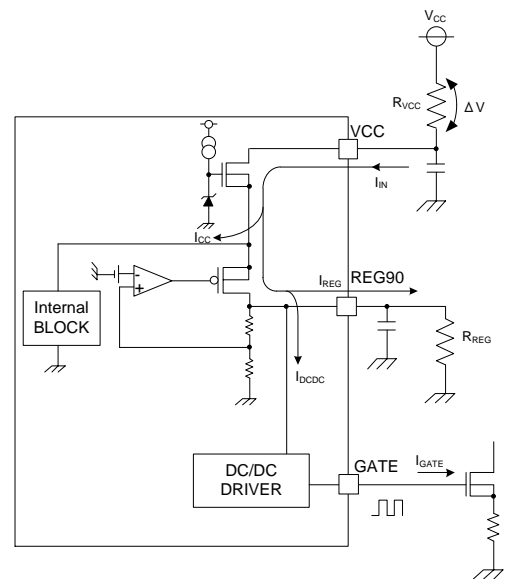

Figure 20. VCC Series Resistance Circuit Example

[Setting Example]

Above equation is translated as follows.

$$R_{VCC} = \frac{V_{IN} - 9}{I_{CC} + I_{DCDC} + I_{REG}}$$

When V<sub>IN</sub>=24V, I<sub>CC</sub>=3.0mA, I<sub>DCDC</sub>=2.0mA, I<sub>REG</sub>=0.9mA (R<sub>REG</sub>=10kΩ), R<sub>VCC</sub> value is calculated as follows.

$$R_{VCC} = \frac{24 - 9}{(0.003 + 0.002 + 0.0009) \times 1000} = 2.54 \quad [k\Omega]$$

Set each values with tolerance and margin.

Selection of Components Externally Connected – continued

4 LED Current Setting

LED current can be adjusted by setting the resistance  $R_S[\Omega]$  which connects to the ISENSE pin and ADIM[V].

With DC dimming ( $V_{ADIM} < 3.03V$ )

$$R_S = \frac{1}{2} \times \frac{V_{ADIM}}{I_{LED}} \quad [\Omega]$$

$R_S$  is the external resistance of ISENSE.  
 $V_{ADIM}$  is the ADIM pin voltage.  
 $I_{LED}$  is LED current.

Without DC dimming ( $V_{ADIM} \geq 3.03V$ )

$$R_S = \frac{1}{2} \times \frac{3.03}{I_{LED}} \quad [\Omega]$$

[Setting Example]

When  $I_{LED}=200mA$ ,  $V_{ADIM}=2.0V$ ,  $R_S$  is as below.

$$R_S = \frac{1}{2} \times \frac{V_{ADIM}}{I_{LED}} = \frac{1}{2} \times \frac{2.0}{0.2} = 5 \quad [\Omega]$$

5 DC/DC Oscillation Frequency Setting

$R_{RT}$  which connects to the RT pin sets DC/DC oscillation frequency  $f_{sw}$ .

$$R_{RT} = \frac{15000}{f_{SW} \times 10^{-3}} \quad [k\Omega]$$

$R_{RT}$  is the external resistance of RT.  
 $f_{sw}$  is DC/DC oscillation frequency.

[Setting Example]

When  $f_{sw}=200kHz$ ,  $R_{RT}$  is as follows.

$$R_{RT} = \frac{15000}{f_{SW} \times 10^{-3}} = \frac{15000}{200 \times 10^3 \times 10^{-3}} = 75 \quad [k\Omega]$$

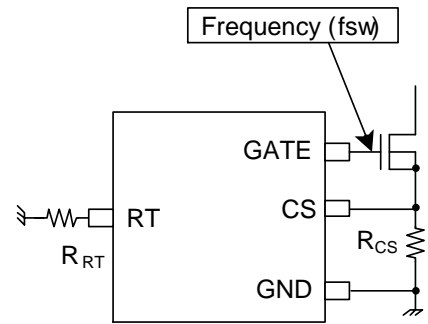

Figure 21. The RT Pin Setting Example

6 ODP Setting

$R_{DUTYP}$  which connects to the DUTYP pin sets the ODP detection duty.

$$R_{DUTYP} = \frac{1172 \times ODP_{DUTY}}{f_{PWM}} \quad [k\Omega]$$

$R_{DUTYP}$  is the external resistance of DUTYP.  
 $ODP_{DUTY}$  is ODP detection duty [%]  
 $f_{PWM}$  is PWM frequency.

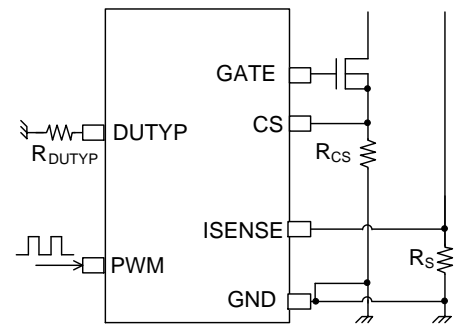

Figure 22. The ODP Pin Setting Example

[Setting Example]

When  $f_{PWM}=120Hz$ ,  $ODP_{DUTY}=35\%$ ,  $R_{DUTYP}$  is as follows.

$$R_{DUTYP} = \frac{1172 \times 35}{120} = 341.8 \quad [k\Omega]$$

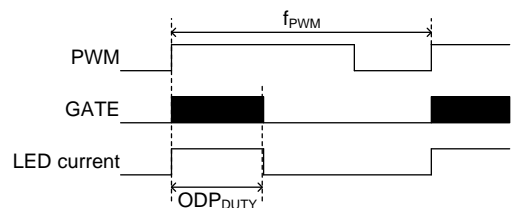

Figure 23. PWM Dimming Wave Form at ODP

## Selection of Components Externally Connected – continued

### 7 OVP Setting

The OVP pin is the input for over-voltage protection of output voltage.

Even if OVP function is not used, input appropriate voltage because the open connection of this pin is not a fixed voltage.

#### (1)OVP Detection Equation

If  $V_{OUT}$  is boosted abnormally,  $V_{OV\text{PDET}}$  (the detect voltage of OVP),  $R_1$ ,  $R_2$  can be expressed by the following formula.

$$R_1 = R_2 \times \frac{(V_{OV\text{PDET}} - 3.0)}{3.0} \quad [\Omega]$$

where:

$V_{OV\text{PDET}}$  is OVP detection voltage in  $V_{OUT}$ .

$R_1$  is resistance between the OVP pin and  $V_{OUT}$ .

$R_2$  is resistance between the OVP pin and GND.

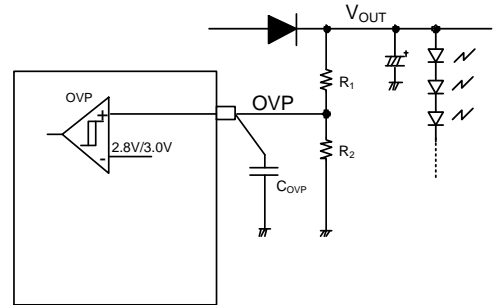

Figure 24. OVP Setting Example

#### (2)OVP Release Equation

By using  $R_1$  and  $R_2$  in the above equation, the release voltage of OVP,  $V_{OV\text{PCAN}}$  can be expressed as follows.

$$V_{OV\text{PCAN}} = 2.8V \times \frac{(R_1 + R_2)}{R_2} \quad [V]$$

where:

$V_{OV\text{PCAN}}$  is OVP release voltage.

#### [Setting Example]

When  $V_{OUT}=40V$ ,  $V_{OV\text{PDET}}=48V$ ,  $R_2=10k\Omega$ ,  $R_1$  is as follows.

$$R_1 = R_2 \times \frac{(V_{OV\text{PDET}} - 3.0)}{3.0} = 10 \times 10^3 \times \frac{(48 - 3)}{3} = 150 \times 10^3 \quad [\Omega]$$

By using these  $R_1$  and  $R_2$ , the release voltage of OVP,  $V_{OV\text{PCAN}}$  is as follows.

$$V_{OV\text{PCAN}} = 2.8 \times \frac{(R_1 + R_2)}{R_2} = 2.8 \times \frac{(150 \times 10^3 + 10 \times 10^3)}{10 \times 10^3} = 44.8 \quad [V]$$

### 8 Abnormal Detection Time and Auto-Restart Time Setting

About over boost protection (FBMAX), abnormal detection counter (CP Counter) is set by counting GATE clk frequency which is set at the RT pin. About the behavior from abnormal detection to latch-off and auto-restart, refer to the section "Timing Chart".

The condition  $V_{SS\text{FB}} \geq 4.0V$  and PWM=H continues to count 4 GATE clks, counting starts from the timing. After that, only the SSFB voltage is monitored and latch off occurs after below time has passed.

$$t_{LATCH} = 2^{11} \times \frac{R_{RT}}{1.5 \times 10^{10}} = 2048 \times \frac{R_{RT}}{1.5 \times 10^{10}} \quad [s]$$

$$t_{AUTO} = 2^{17} \times \frac{R_{RT}}{1.5 \times 10^{10}} = 131072 \times \frac{R_{RT}}{1.5 \times 10^{10}} \quad [s]$$

where:

$t_{LATCH}$  is the time until latch condition occurs.

$t_{AUTO}$  is the auto restart time.

$R_{RT}$  is the resistor value connected to the RT pin.

#### [Setting Example]

When  $R_{RT}$  is 100k $\Omega$ ,  $t_{LATCH}$  and  $t_{AUTO}$  are as follows.

$$t_{LATCH} = 2048 \times \frac{100 \times 10^3}{1.5 \times 10^{10}} = 13.7 \quad [ms]$$

$$t_{AUTO} = 131072 \times \frac{100 \times 10^3}{1.5 \times 10^{10}} = 873.8 \quad [ms]$$

Selection of Components Externally Connected – continued

9 OCP Setting/Calculation Method for the Current Rating of DC/DC Parts

OCP detection stops the switching when the CS pin voltage is 0.4V or more. The resistor value of the CS pin,  $R_{CS}$  needs to be considered by the inductor current. And the current rating of DC/DC external parts is required more than the peak current of the inductor.

Shown below are the calculation method of the inductor peak current, the selection method of  $R_{CS}$  (the resistor value of the CS pin) and the current rating of the external DC/DC parts at Continuous Current Mode.

(The calculation method of the inductor peak current,  $I_{PEAK}$  at continuous current mode)

At first, since the ripple voltage at the CS pin depends on the application condition of DC/DC. And then, the average input current of the inductor is calculated as follows.

$$I_{IN} = \frac{V_{OUT} \times I_{OUT}}{V_{IN} \times \eta \times 10^{-2}} \quad [A]$$

$I_{IN}$  is the average input current of the inductor.  
 $V_{OUT}$  is DC/DC output voltage.  
 $I_{OUT}$  is LED total current.  
 $V_{IN}$  is DC/DC input voltage.  
 $\eta$  is Efficiency of DC/DC [%].

And the ripple current of the inductor caused by DC/DC operation can be calculated as follows.

$$\Delta I_L = \frac{(V_{OUT} - V_{IN}) \times V_{IN}}{L \times V_{OUT} \times f_{SW}} \quad [A]$$

$\Delta I_L$  is the ripple current of the inductor.  
 $L$  is the inductor value.  
 $f_{SW}$  is DC/DC oscillation frequency.

On the other hand, the peak current of the inductor  $I_{PEAK}$  is as follows.

$$I_{PEAK} = I_{IN} + \frac{\Delta I_L}{2} \quad [A] \quad (1)$$

$I_{PEAK}$  is the peak current of the inductor.

Therefore, the bottom current of the inductor is as follows.

$$I_{MIN} = I_{IN} - \frac{\Delta I_L}{2} \quad \text{or} \quad 0 \quad [A]$$

$I_{MIN}$  is the bottom current of the inductor.

If  $I_{MIN} > 0$ , the operation mode is CCM(Continuous Current Mode), otherwise the mode is DCM(Discontinuous Current Mode).

(The selection method of  $R_{CS}$  at Continuous Current Mode)

$I_{PEAK}$  flows into  $R_{CS}$  and that causes the voltage signal to the CS pin. (Refer to the timing chart at the right)  
 The peak voltage of the CS pin is as follows.

$$V_{CSPEAK} = R_{CS} \times I_{PEAK} \quad [V]$$

$V_{CSPEAK}$  is the peak voltage of the CS pin.

As this  $V_{CSPEAK}$  reaches 0.4V, the DC/DC output stops the switching. Therefore,  $R_{CS}$  value is necessary to meet the condition below.

$$R_{CS} \times I_{PEAK} \ll 0.4 \quad [V]$$

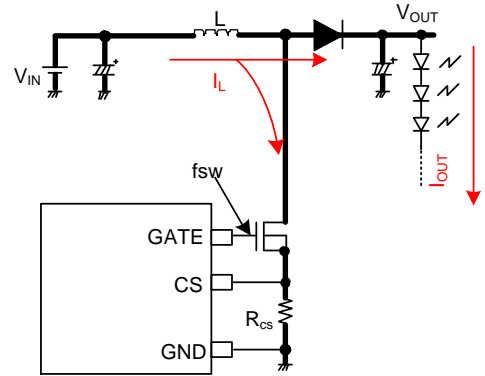

Figure 25. Calculation Method of  $I_{PEAK}$

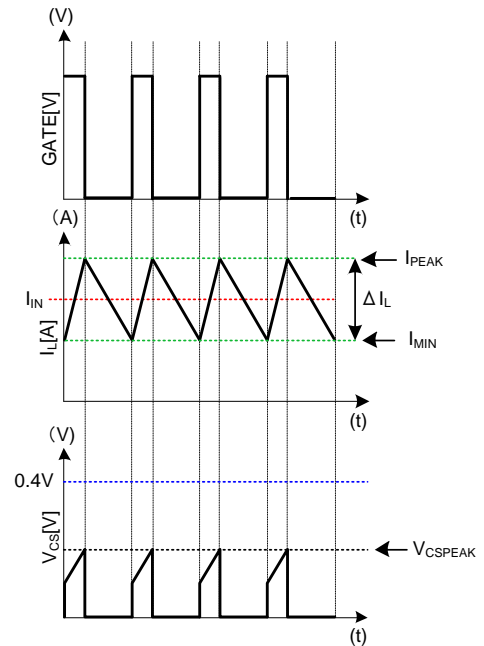

Figure 26. Inductor Current Waveform



## Selection of Components Externally Connected – continued

### (The current rating of the external DC/DC parts)

The peak current as the CS voltage reaches OCP level(0.4V) is defined as  $I_{PEAK\_DET}$ .

$$I_{PEAK\_DET} = \frac{0.4}{R_{CS}} \quad [A] \quad (2)$$

$I_{PEAK\_DET}$  is the inductor peak current when  $V_{CS}$  is 0.4V.

The relationship among  $I_{PEAK}$ (equation(1)),  $I_{PEAK\_DET}$ (equation(2)) and the current rating of parts is required to meet the following.

$$I_{PEAK} \ll I_{PEAK\_DET} \ll \textit{The current rating of parts}$$

Make the selection of the external parts such as FET, Inductor, diode meet the above condition.

### [Setting Example]

When  $V_{OUT}=40V$ ,  $I_{OUT}=0.48A$ ,  $V_{IN}=24V$ ,  $\eta=90\%$ ,  $I_{IN}$  is as follows.

$$I_{IN} = \frac{V_{OUT} \times I_{OUT}}{V_{IN} \times \eta \times 10^{-2}} = \frac{40 \times 0.48}{24 \times 90 \times 10^{-2}} = 0.89 \quad [A]$$

If  $f_{SW}=200kHz$ ,  $L=100\mu H$ ,  $\Delta I_L$  can be calculated as follows.

$$\Delta I_L = \frac{(V_{OUT}-V_{IN}) \times V_{IN}}{L \times V_{OUT} \times f_{SW}} = \frac{(40-24) \times 24}{100 \times 10^{-6} \times 40 \times 200 \times 10^3} = 0.48 \quad [A]$$

Therefore the inductor peak current  $I_{PEAK}$  is as follows.

$$I_{PEAK} = I_{IN} + \frac{\Delta I_L}{2} = 0.89 + \frac{0.48}{2} = 1.13 \quad [A]$$

If  $R_{CS}$  is assumed to be  $0.3\Omega$ ,  $V_{CSPEAK}$  is as follows.

$$V_{CSPEAK} = R_{CS} \times I_{PEAK} = 0.3 \times 1.13 = 0.339 \ll 0.4 \quad [V]$$

That meets the above condition.

And  $I_{PEAK\_DET}$  that is the current OCP works is as follows.

$$I_{PEAK\_DET} = \frac{0.4}{R_{CS}} = \frac{0.4}{0.3} = 1.33 \quad [A]$$

If the current rating of the used parts is 2A,

$$I_{PEAK} \ll I_{PEAK\_DET} \ll \textit{The current rating} = 1.13 \ll 1.33 \ll 2.0 \quad [A]$$

This inequality meets the above relationship. The parts selection is proper.

And  $I_{MIN}$  that is the bottom of the  $I_L$  ripple current can be calculated as follows.

$$I_{MIN} = I_{IN} - \frac{\Delta I_L}{2} = 0.89 - 0.24 = 0.65 \gg 0 \quad [A]$$

This inequality implies that the operation is continuous current mode.

## Selection of Components Externally Connected – continued

### 10 Inductor Selection

The inductor value affects the input ripple current, as shown the previous section [“OCP Setting/Calculation Method for the Current Rating of DC/DC Parts”](#).

$$\Delta I_L = \frac{(V_{OUT} - V_{IN}) \times V_{IN}}{L \times V_{OUT} \times f_{SW}} \quad [A]$$

$$I_{IN} = \frac{V_{OUT} \times I_{OUT}}{V_{IN} \times \eta \times 10^{-2}} \quad [A]$$

$$I_{PEAK} = I_{IN} + \frac{\Delta I_L}{2} \quad [A]$$

where:

$L$  is the inductor inductance.

$V_{OUT}$  is the DC/DC output voltage.

$V_{IN}$  is the input voltage.

$I_{OUT}$  is the output load current (the summation of LED current).

$I_{IN}$  is the input current.

$f_{SW}$  is the oscillation frequency.

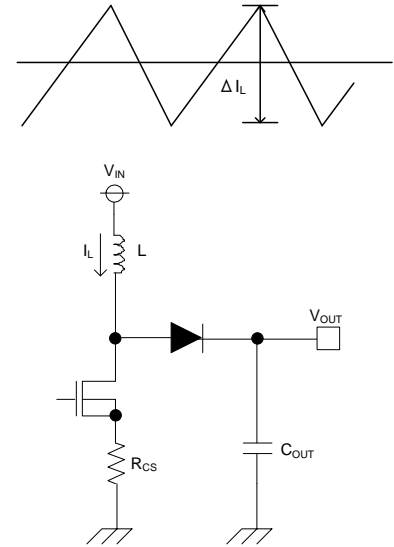

Figure 27. Inductor Current Waveform and Diagram

In continuous current mode,  $\Delta I_L$  is set to 30% to 50% of the output load current in many cases.

In using smaller inductor, the operation mode is the discontinuous current mode in which the inductor current returns to zero at every period. The current exceeding the rated current value of inductor flow through the inductor causes magnetic saturation, results in decreasing in efficiency. Inductor needs to be selected to have such adequate margin that peak current does not exceed the rated current value of the inductor. To reduce inductor loss and improve efficiency, inductor with low resistance components (DCR, ACR) needs to be selected.

### 11 Output Capacitance $C_{OUT}$ Selection

Output capacitor needs to be selected in consideration of the capacitance value  $C_{OUT}$  and the equivalent series resistance  $R_{ESR}$ .  $R_{ESR}$  of it needs to be small enough to smooth ripple voltage.

Output ripple voltage  $\Delta V_{OUT}$  is determined as follows.

$$\Delta V_{OUT} = \Delta I_L \times R_{ESR} \quad [V]$$

where:

$\Delta V_{OUT}$  is  $V_{OUT}$  ripple voltage.

$\Delta I_L$  is LED ripple current.

$R_{ESR}$  is the equivalent series resistance of output capacitance.

When the inductor current is charged to the output capacitor as MOS turns off, much output ripple is caused. If output ripple voltage is big, that causes the LED current ripple is big.

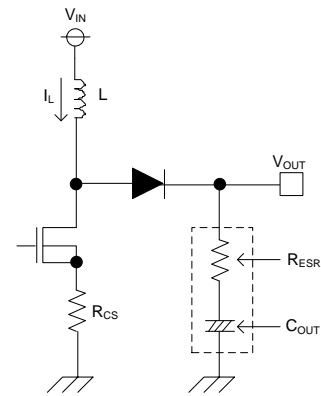

Figure 28. Output Capacitor Diagram

Rating of capacitor needs to be selected to have adequate margin for output voltage.

To use an electrolytic capacitor, adequate margin for allowable current is also necessary. Be aware that the LED current is more than the set value transitionally in case that LED is provided with PWM dimming especially.

### 12 MOSFET Selection

There is no problem if the absolute maximum rating is more than the sum of  $V_{OVPOUT}$  (OVP detection voltage in  $V_{OUT}$ ) and  $V_F$  (the forward voltage of the rectifying diode). Recommended rated current is more than over current protection setting. The product with small gate capacitance (injected charge) needs to be selected to achieve high-speed switching. The selection of one with small on resistance results in high efficiency.

### 13 Rectifying Diode Selection

A schottky barrier diode with rated current of  $L$  or more, reverse voltage more than  $V_{OVPOUT}$ , and low forward voltage  $V_F$  especially needs to be selected.

## Selection of Components Externally Connected – continued

## 14 Loop Compensation

A current mode DC/DC converter has each one pole (phase lag)  $f_P$  due to CR filter composed of the output capacitor and the output resistance(=LED current) and zero (phase lead)  $f_Z$  by the output capacitor and the ESR of the capacitor. Moreover, a step up DC/DC converter has RHP zero(right-half plane zero point)  $f_{ZRHP}$  which is unique with the boost converter. This zero may cause the unstable feedback. To avoid this by RHP zero, the loop compensation band frequency  $f_C$ , set as follows, is suggested.

$$f_C = \frac{f_{ZRHP}}{5} \quad [\text{Hz}]$$

where:

$f_C$  is loop compensation band frequency.

$f_{ZRHP}$  is RHP zero frequency.

Considering the response speed, the calculated constant below is not always optimized completely. It needs to be adequately verified with an actual device.

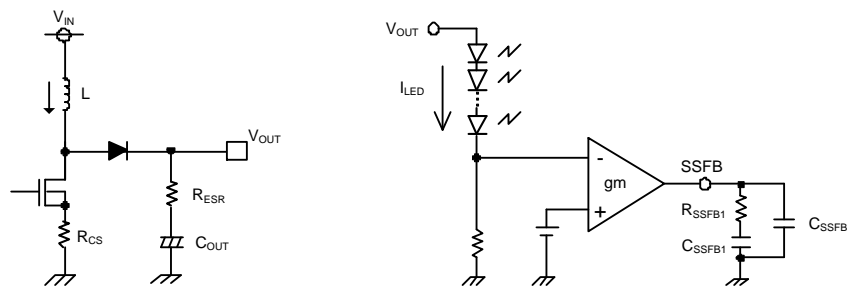

Figure 29. Output Stage and Error Amplifier Diagram

(1) Calculate the pole frequency  $f_P$  and the RHP zero frequency  $f_{ZRHP}$  of DC/DC converter.

$$f_P = \frac{I_{LED}}{2\pi \times V_{OUT} \times C_{OUT}} \quad [\text{Hz}]$$

$$f_{ZRHP} = \frac{V_{OUT} \times (1-D)^2}{2\pi \times L \times I_{LED}} \quad [\text{Hz}]$$

where:

$f_P$  is DC/DC pole frequency.

$f_{ZRHP}$  is RHP zero frequency.

D is switching duty. ( $D = \frac{V_{OUT} - V_{IN}}{V_{OUT}}$ )

(2) Calculate the phase compensation of the error amp output ( $f_C = f_{ZRHP}/5$ ).

$$R_{SSFB1} = \frac{f_{RHZP} \times R_{CS} \times I_{LED}}{5 \times f_P \times gm \times V_{OUT} \times (1-D)} \quad [\Omega]$$

$$C_{SSFB1} = \frac{1}{2\pi \times R_{SSFB1} \times f_C} = \frac{5}{2\pi \times R_{SSFB1} \times f_{ZRHP}} \quad [\text{F}]$$

$$gm = 4.0 \times 10^{-4} \quad [\text{S}]$$

Above equation is described for lighting LED without the oscillation. The value may cause much error if the quick response for the abrupt change of dimming signal is required.

To improve the transient response,  $R_{SSFB1}$  needs to be increased, and  $C_{SSFB1}$  needs to be decreased. It needs to be adequately verified with an actual device in consideration of variation from parts to parts since phase margin is decreased.

I/O Equivalent Circuits

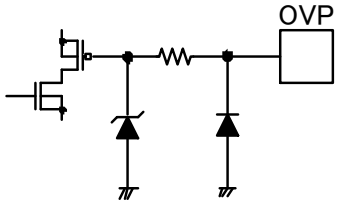
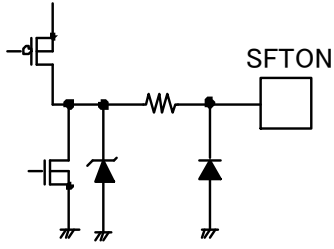
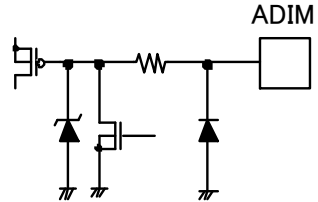
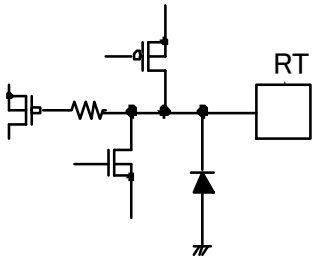
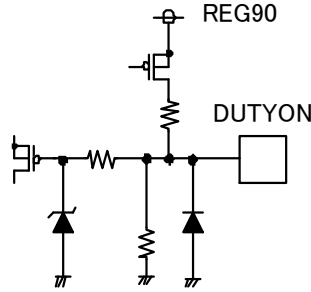
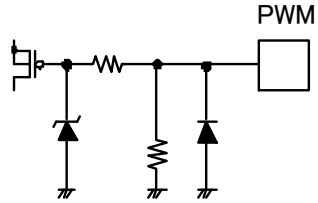
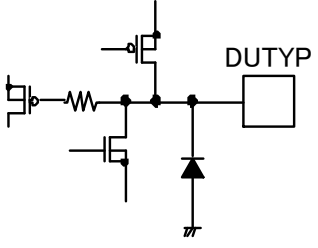
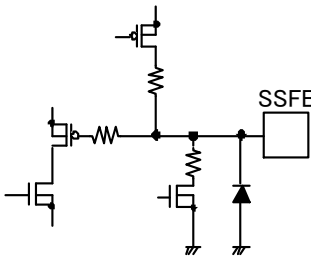
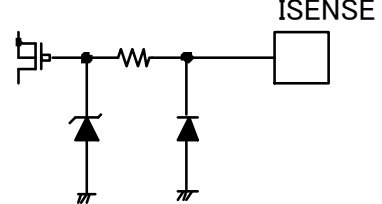
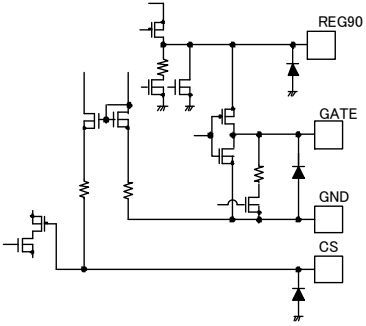
<p>Pin2: OVP</p> 	<p>Pin3: SFTON</p> 	<p>Pin4: ADIM</p> 	
<p>Pin5: RT</p> 	<p>Pin6: DUTYON</p> 	<p>Pin7: PWM</p> 	
<p>Pin8: DUTYP</p> 	<p>Pin9: SSFB</p> 	<p>Pin10: ISENSE</p> 	
<p>Pin12: GATE, Pin13: CS, Pin14: REG90</p> 			

## Operational Notes

### 1. Reverse Connection of Power Supply

Connecting the power supply in reverse polarity can damage the IC. Take precautions against reverse polarity when connecting the power supply, such as mounting an external diode between the power supply and the IC's power supply pins.

### 2. Power Supply Lines

Design the PCB layout pattern to provide low impedance supply lines. Furthermore, connect a capacitor to ground at all power supply pins. Consider the effect of temperature and aging on the capacitance value when using electrolytic capacitors.

### 3. Ground Voltage

Ensure that no pins are at a voltage below that of the ground pin at any time, even during transient condition.

### 4. Ground Wiring Pattern

When using both small-signal and large-current ground traces, the two ground traces should be routed separately but connected to a single ground at the reference point of the application board to avoid fluctuations in the small-signal ground caused by large currents. Also ensure that the ground traces of external components do not cause variations on the ground voltage. The ground lines must be as short and thick as possible to reduce line impedance.

### 5. Recommended Operating Conditions

The function and operation of the IC are guaranteed within the range specified by the recommended operating conditions. The characteristic values are guaranteed only under the conditions of each item specified by the electrical characteristics.

### 6. Inrush Current

When power is first supplied to the IC, it is possible that the internal logic may be unstable and inrush current may flow instantaneously due to the internal powering sequence and delays, especially if the IC has more than one power supply. Therefore, give special consideration to power coupling capacitance, power wiring, width of ground wiring, and routing of connections.

### 7. Operation Under Strong Electromagnetic Field

Operating the IC in the presence of a strong electromagnetic field may cause the IC to malfunction.

### 8. Testing on Application Boards

When testing the IC on an application board, connecting a capacitor directly to a low-impedance output pin may subject the IC to stress. Always discharge capacitors completely after each process or step. The IC's power supply should always be turned off completely before connecting or removing it from the test setup during the inspection process. To prevent damage from static discharge, ground the IC during assembly and use similar precautions during transport and storage.

### 9. Inter-pin Short and Mounting Errors

Ensure that the direction and position are correct when mounting the IC on the PCB. Incorrect mounting may result in damaging the IC. Avoid nearby pins being shorted to each other especially to ground, power supply and output pin. Inter-pin shorts could be due to many reasons such as metal particles, water droplets (in very humid environment) and unintentional solder bridge deposited in between pins during assembly to name a few.

### 10. Unused Input Pins

Input pins of an IC are often connected to the gate of a MOS transistor. The gate has extremely high impedance and extremely low capacitance. If left unconnected, the electric field from the outside can easily charge it. The small charge acquired in this way is enough to produce a significant effect on the conduction through the transistor and cause unexpected operation of the IC. So unless otherwise specified, unused input pins should be connected to the power supply or ground line.

## Operational Notes – continued

**11. Regarding the Input Pin of the IC**

This monolithic IC contains P+ isolation and P substrate layers between adjacent elements in order to keep them isolated. P-N junctions are formed at the intersection of the P layers with the N layers of other elements, creating a parasitic diode or transistor. For example (refer to figure below):

When  $GND > Pin A$  and  $GND > Pin B$ , the P-N junction operates as a parasitic diode.

When  $GND > Pin B$ , the P-N junction operates as a parasitic transistor.

Parasitic diodes inevitably occur in the structure of the IC. The operation of parasitic diodes can result in mutual interference among circuits, operational faults, or physical damage. Therefore, conditions that cause these diodes to operate, such as applying a voltage lower than the GND voltage to an input pin (and thus to the P substrate) should be avoided.

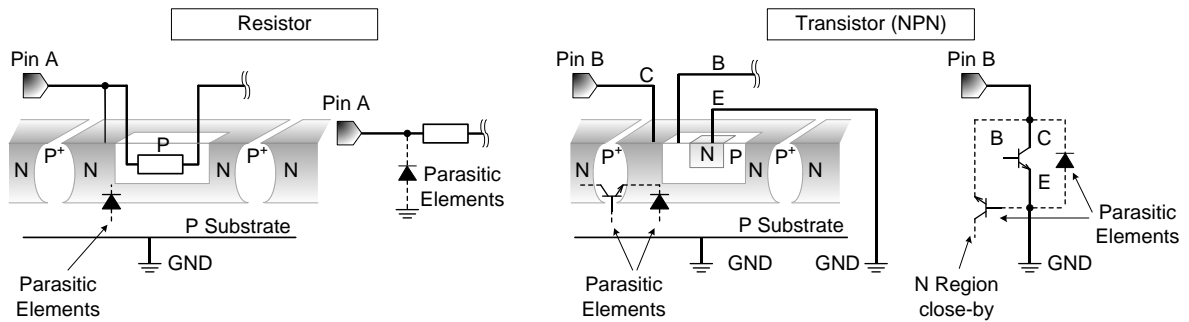

Figure 30. Example of monolithic IC structure

**12. Ceramic Capacitor**

When using a ceramic capacitor, determine a capacitance value considering the change of capacitance with temperature and the decrease in nominal capacitance due to DC bias and others.

**13. Area of Safe Operation (ASO)**

Operate the IC such that the output voltage, output current, and the maximum junction temperature rating are all within the Area of Safe Operation (ASO).

**14. Thermal Shutdown Circuit (TSD)**

This IC has a built-in thermal shutdown circuit that prevents heat damage to the IC. Normal operation should always be within the IC's maximum junction temperature rating. If however the rating is exceeded for a continued period, the junction temperature ( $T_j$ ) will rise which will activate the TSD circuit that will turn OFF power output pins. When the  $T_j$  falls below the TSD threshold, the circuits are automatically restored to normal operation.

Note that the TSD circuit operates in a situation that exceeds the absolute maximum ratings and therefore, under no circumstances, should the TSD circuit be used in a set design or for any purpose other than protecting the IC from heat damage.

**15. Over Current Protection Circuit (OCP)**

This IC incorporates an integrated overcurrent protection circuit that is activated when the load is shorted. This protection circuit is effective in preventing damage due to sudden and unexpected incidents. However, the IC should not be used in applications characterized by continuous operation or transitioning of the protection circuit.

Ordering Information

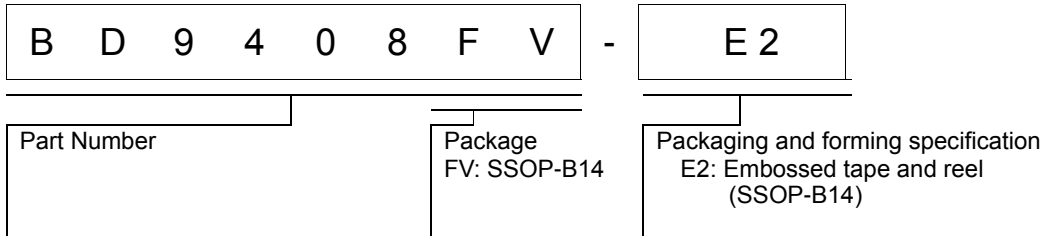

Marking Diagram

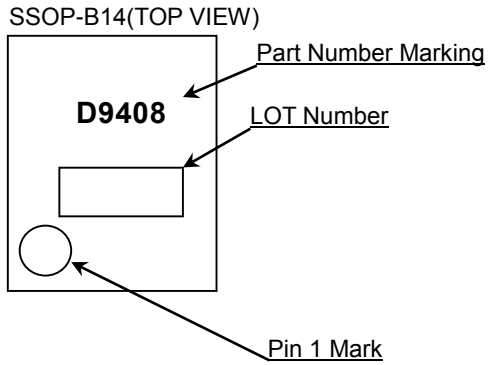

Physical Dimension and Packing Information

Package Name	SSOP-B14
--------------	----------

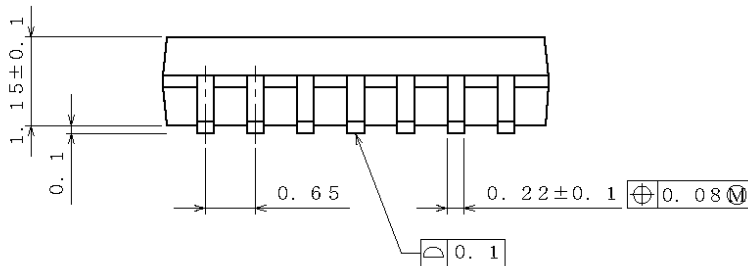
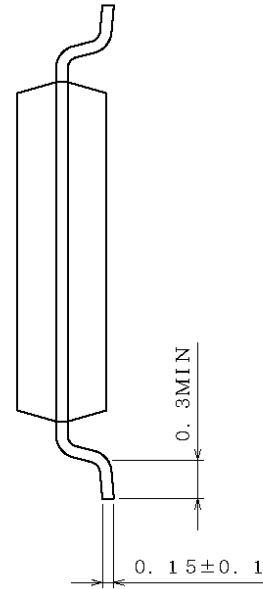
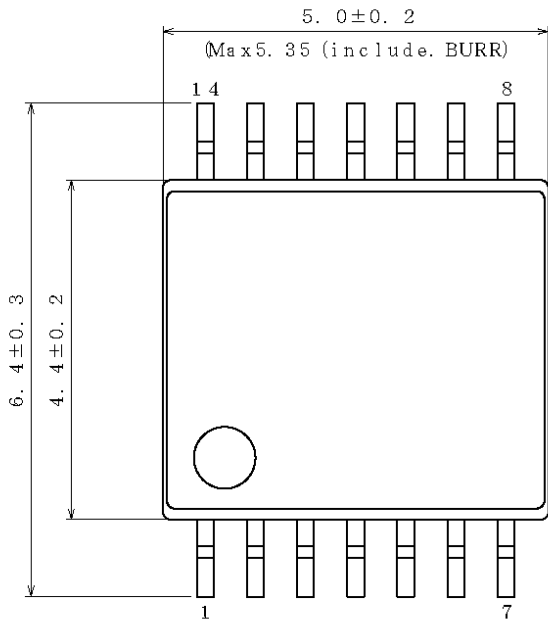

(UNIT : mm)  
 PKG : SSOP-B14  
 Drawing No. EX152-5002

<Tape and Reel information>

Tape	Embossed carrier tape
Quantity	2500pcs
Direction of feed	E2 ( The direction is the 1pin of product is at the upper left when you hold reel on the left hand and you pull out the tape on the right hand )

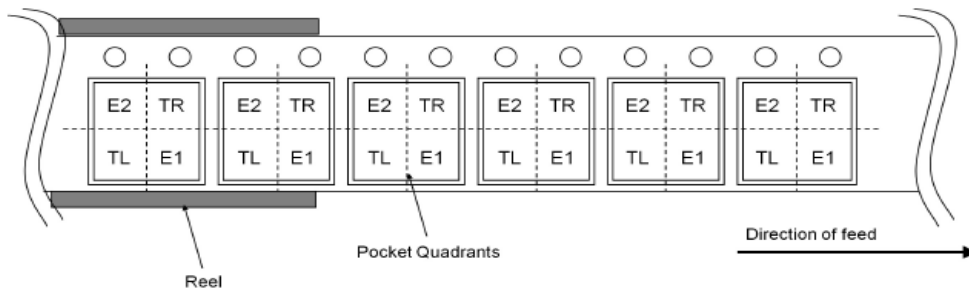



**Revision History**

Date	Revision	Changes
16.May.2018	001	New Release

# Notice

## Precaution on using ROHM Products

- Our Products are designed and manufactured for application in ordinary electronic equipment (such as AV equipment, OA equipment, telecommunication equipment, home electronic appliances, amusement equipment, etc.). If you intend to use our Products in devices requiring extremely high reliability (such as medical equipment <sup>(Note 1)</sup>, transport equipment, traffic equipment, aircraft/spacecraft, nuclear power controllers, fuel controllers, car equipment including car accessories, safety devices, etc.) and whose malfunction or failure may cause loss of human life, bodily injury or serious damage to property ("Specific Applications"), please consult with the ROHM sales representative in advance. Unless otherwise agreed in writing by ROHM in advance, ROHM shall not be in any way responsible or liable for any damages, expenses or losses incurred by you or third parties arising from the use of any ROHM's Products for Specific Applications.

(Note1) Medical Equipment Classification of the Specific Applications

JAPAN	USA	EU	CHINA
CLASS III	CLASS III	CLASS II b	CLASS III
CLASS IV		CLASS III	

- ROHM designs and manufactures its Products subject to strict quality control system. However, semiconductor products can fail or malfunction at a certain rate. Please be sure to implement, at your own responsibilities, adequate safety measures including but not limited to fail-safe design against the physical injury, damage to any property, which a failure or malfunction of our Products may cause. The following are examples of safety measures:
  - Installation of protection circuits or other protective devices to improve system safety
  - Installation of redundant circuits to reduce the impact of single or multiple circuit failure
- Our Products are designed and manufactured for use under standard conditions and not under any special or extraordinary environments or conditions, as exemplified below. Accordingly, ROHM shall not be in any way responsible or liable for any damages, expenses or losses arising from the use of any ROHM's Products under any special or extraordinary environments or conditions. If you intend to use our Products under any special or extraordinary environments or conditions (as exemplified below), your independent verification and confirmation of product performance, reliability, etc. prior to use, must be necessary:
  - Use of our Products in any types of liquid, including water, oils, chemicals, and organic solvents
  - Use of our Products outdoors or in places where the Products are exposed to direct sunlight or dust
  - Use of our Products in places where the Products are exposed to sea wind or corrosive gases, including Cl<sub>2</sub>, H<sub>2</sub>S, NH<sub>3</sub>, SO<sub>2</sub>, and NO<sub>2</sub>
  - Use of our Products in places where the Products are exposed to static electricity or electromagnetic waves
  - Use of our Products in proximity to heat-producing components, plastic cords, or other flammable items
  - Sealing or coating our Products with resin or other coating materials
  - Use of our Products without cleaning residue of flux (even if you use no-clean type fluxes, cleaning residue of flux is recommended); or Washing our Products by using water or water-soluble cleaning agents for cleaning residue after soldering
  - Use of the Products in places subject to dew condensation
- The Products are not subject to radiation-proof design.
- Please verify and confirm characteristics of the final or mounted products in using the Products.
- In particular, if a transient load (a large amount of load applied in a short period of time, such as pulse. is applied, confirmation of performance characteristics after on-board mounting is strongly recommended. Avoid applying power exceeding normal rated power; exceeding the power rating under steady-state loading condition may negatively affect product performance and reliability.
- De-rate Power Dissipation depending on ambient temperature. When used in sealed area, confirm that it is the use in the range that does not exceed the maximum junction temperature.
- Confirm that operation temperature is within the specified range described in the product specification.
- ROHM shall not be in any way responsible or liable for failure induced under deviant condition from what is defined in this document.

## Precaution for Mounting / Circuit board design

- When a highly active halogenous (chlorine, bromine, etc.) flux is used, the residue of flux may negatively affect product performance and reliability.
- In principle, the reflow soldering method must be used on a surface-mount products, the flow soldering method must be used on a through hole mount products. If the flow soldering method is preferred on a surface-mount products, please consult with the ROHM representative in advance.

For details, please refer to ROHM Mounting specification

### Precautions Regarding Application Examples and External Circuits

1. If change is made to the constant of an external circuit, please allow a sufficient margin considering variations of the characteristics of the Products and external components, including transient characteristics, as well as static characteristics.
2. You agree that application notes, reference designs, and associated data and information contained in this document are presented only as guidance for Products use. Therefore, in case you use such information, you are solely responsible for it and you must exercise your own independent verification and judgment in the use of such information contained in this document. ROHM shall not be in any way responsible or liable for any damages, expenses or losses incurred by you or third parties arising from the use of such information.

### Precaution for Electrostatic

This Product is electrostatic sensitive product, which may be damaged due to electrostatic discharge. Please take proper caution in your manufacturing process and storage so that voltage exceeding the Products maximum rating will not be applied to Products. Please take special care under dry condition (e.g. Grounding of human body / equipment / solder iron, isolation from charged objects, setting of Ionizer, friction prevention and temperature / humidity control).

### Precaution for Storage / Transportation

1. Product performance and soldered connections may deteriorate if the Products are stored in the places where:
  - [a] the Products are exposed to sea winds or corrosive gases, including Cl<sub>2</sub>, H<sub>2</sub>S, NH<sub>3</sub>, SO<sub>2</sub>, and NO<sub>2</sub>
  - [b] the temperature or humidity exceeds those recommended by ROHM
  - [c] the Products are exposed to direct sunshine or condensation
  - [d] the Products are exposed to high Electrostatic
2. Even under ROHM recommended storage condition, solderability of products out of recommended storage time period may be degraded. It is strongly recommended to confirm solderability before using Products of which storage time is exceeding the recommended storage time period.
3. Store / transport cartons in the correct direction, which is indicated on a carton with a symbol. Otherwise bent leads may occur due to excessive stress applied when dropping of a carton.
4. Use Products within the specified time after opening a humidity barrier bag. Baking is required before using Products of which storage time is exceeding the recommended storage time period.

### Precaution for Product Label

A two-dimensional barcode printed on ROHM Products label is for ROHM's internal use only.

### Precaution for Disposition

When disposing Products please dispose them properly using an authorized industry waste company.

### Precaution for Foreign Exchange and Foreign Trade act

Since concerned goods might be fallen under listed items of export control prescribed by Foreign exchange and Foreign trade act, please consult with ROHM in case of export.

### Precaution Regarding Intellectual Property Rights

1. All information and data including but not limited to application example contained in this document is for reference only. ROHM does not warrant that foregoing information or data will not infringe any intellectual property rights or any other rights of any third party regarding such information or data.
2. ROHM shall not have any obligations where the claims, actions or demands arising from the combination of the Products with other articles such as components, circuits, systems or external equipment (including software).
3. No license, expressly or implied, is granted hereby under any intellectual property rights or other rights of ROHM or any third parties with respect to the Products or the information contained in this document. Provided, however, that ROHM will not assert its intellectual property rights or other rights against you or your customers to the extent necessary to manufacture or sell products containing the Products, subject to the terms and conditions herein.

### Other Precaution

1. This document may not be reprinted or reproduced, in whole or in part, without prior written consent of ROHM.
2. The Products may not be disassembled, converted, modified, reproduced or otherwise changed without prior written consent of ROHM.
3. In no event shall you use in any way whatsoever the Products and the related technical information contained in the Products or this document for any military purposes, including but not limited to, the development of mass-destruction weapons.
4. The proper names of companies or products described in this document are trademarks or registered trademarks of ROHM, its affiliated companies or third parties.

**General Precaution**

1. Before you use our Products, you are requested to carefully read this document and fully understand its contents. ROHM shall not be in any way responsible or liable for failure, malfunction or accident arising from the use of any ROHM's Products against warning, caution or note contained in this document.
2. All information contained in this document is current as of the issuing date and subject to change without any prior notice. Before purchasing or using ROHM's Products, please confirm the latest information with a ROHM sales representative.
3. The information contained in this document is provided on an "as is" basis and ROHM does not warrant that all information contained in this document is accurate and/or error-free. ROHM shall not be in any way responsible or liable for any damages, expenses or losses incurred by you or third parties resulting from inaccuracy or errors of or concerning such information.