

General EMI Filter with High Attenuation Performance

General Purpose EMI Filter AMI-21 Series



- Rated current from 1 to 60 A
- Single stage filter
- General purpose filtering performance
- Optional medical version (Type B)
- Optional safety version (Type A)

Approvals:



Technical Specifications

Maximum continuous operating voltage: 250VAC, 50/60Hz

Operating frequency: DC to 400Hz

Rated currents: 1 to 60A @ 40°C max.

High potential test voltage: L → PE 3000VDC for 2 sec (standard types)

L → PE 3500VDC for 2 sec (B types)

L → N 1100VDC for 2 sec

Temperature range (operation and storage): -25°C to +100°C (25/100/21)

Design corresponding to: UL 1283.

CIRCUIT DIAGRAM:

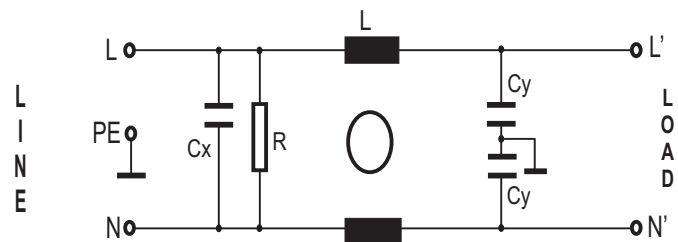

Features and Benefits

- AMI-21 Single stage filters are designed for easy and fast chassis mounting.
- The AMI-21 filters are also available as B versions with no Y-capacitors for medical applications as well as A versions with low capacitance for safety critical applications with requirements for low leakage currents.
- All filters provide a general purpose conducted attenuation performance, based on chokes with high saturation resistance and excellent thermal behavior.
- The AMI-21 filter can be use to cover a broad range of uses and they offer a good size/ampere ratio.
- AMI-21 filters are also available as multi-stage filters (AMI-26 series).
- Various terminal options allow you to select the desired connection style

Typical Applications

- Consumer electronics
- Computing & accessories
- Residential appliances
- Medical accessories
- Electronic data processing equipment
- Office automation equipment
- Power supplies

General EMI Filter with High Attenuation Performance



FILTER SELECTION TABLE

	Rated current @40°C (25°C)	Leakage current @ 250VAC/50Hz (@ 120VAC/60Hz)	Inductance ΣL	Capacitance ΣCx	Capacitance ΣCy	Resistance ΣR	Connetion type		
	A	mA	mH	μF	nF	K_{Ω}			
AMI-21-1-X	1 (1.15)	0.74 (0.43)	12	0.1	9.4	1000	1	3	
AMI-21-3-X	3 (3.45)	0.74 (0.43)	2.5	0.1	9.4	1000	1	3	
AMI-21-6-X	6 (6.90)	0.74 (0.43)	1.0	0.1	9.4	1000	1	3	
AMI-21-10-X	10 (11.5)	0.74 (0.43)	0.8	0.1	9.4	1000	1	3	
AMI-21-12-X	12 (13.8)	0.74 (0.43)	0.7	0.1	9.4	1000	1	3	
AMI-21-13-X	13 (15.0)	0.74 (0.43)	0.7	0.1	9.4	1000	1	3	
AMI-21-16-X	16 (18.4)	0.74 (0.43)	0.6	0.1	9.4	1000	1	3	
AMI-21-20-X	20 (23.0)	1.45 (0.90)	0.7	0.47	20	1000	1	3	6
AMI-21-30-X	30 (34.5)	1.45 (0.90)	0.7	0.47	20	1000			6
AMI-21-60-X	60 (69.0)	1.45 (0.90)	1.0	1.50	20	1000			6
AMI-21A-1-X	1 (1.15)	0.074 (0.04)	12	0.1	0.94	1000	1	3	
AMI-21A-3-X	3 (3.45)	0.074 (0.04)	2.5	0.1	0.94	1000	1	3	
AMI-21A-6-X	6 (6.90)	0.074 (0.04)	1.0	0.1	0.94	1000	1	3	
AMI-21A-10-X	10 (11.5)	0.074 (0.04)	0.8	0.1	0.94	1000	1	3	
AMI-21A-12-X	12 (13.8)	0.074 (0.04)	0.7	0.1	0.94	1000	1	3	
AMI-21A-13-X	13 (15.0)	0.074 (0.04)	0.7	0.1	0.94	1000	1	3	
AMI-21A-16-X	16 (18.4)	0.074 (0.04)	0.6	0.1	0.94	1000	1	3	
AMI-21A-20-X	20 (23.0)	0.074 (0.04)	0.7	0.47	0.94	1000	1	3	6
AMI-21A-30-X	30 (34.5)	0.074 (0.04)	0.7	0.47	20	1000			6
AMI-21A-60-X	60 (69.0)	0.074 (0.04)	1.0	1.50	20	1000			6
AMI-21B-1-X	1 (1.15)	0.02 (0.01)	12	0.1	0.94	1000	1	3	
AMI-21B-3-X	3 (3.45)	0.02 (0.01)	2.5	0.1	0.94	1000	1	3	
AMI-21B-6-X	6 (6.90)	0.02 (0.01)	1.0	0.1	0.94	1000	1	3	
AMI-21B-10-X	10 (11.5)	0.02 (0.01)	0.8	0.1	0.94	1000	1	3	
AMI-21B-12-X	12 (13.8)	0.02 (0.01)	0.7	0.1	0.94	1000	1	3	
AMI-21B-13-X	13 (15.0)	0.02 (0.01)	0.7	0.1	0.94	1000	1	3	
AMI-21B-16-X	16 (18.4)	0.02 (0.01)	0.6	0.1	0.94	1000	1	3	
AMI-21B-20-X	20 (23.0)	0.02 (0.01)	0.7	0.47	0.94	1000	1	3	6
AMI-21B-30-X	30 (34.5)	0.02 (0.01)	0.7	0.47	20	1000			6
AMI-21A-60-X	60 (69.0)	0.02 (0.01)	1.0	1.50	20	1000			6

Where X denotes connection style

Insertion Loss: Common mode - —
 Differential mode - —

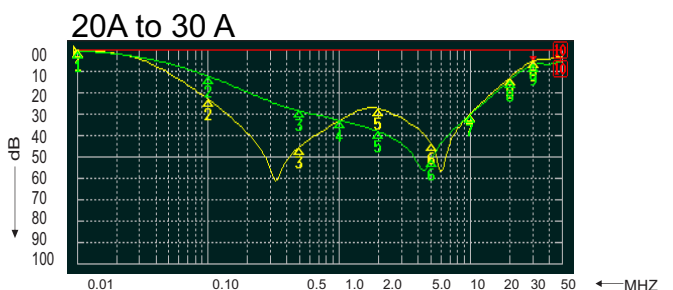
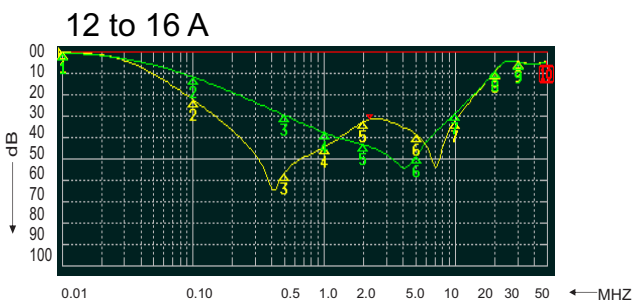
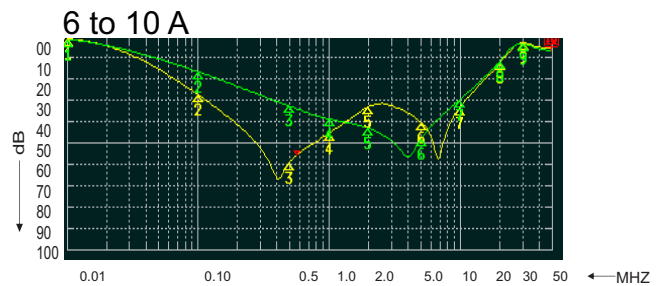
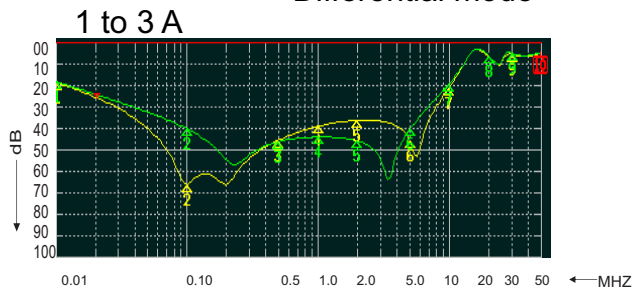

General EMI Filter with High Attenuation Performance

MECHANICAL DIMENSION (mm):

CONNECTION TYPE -1
1A to 6A

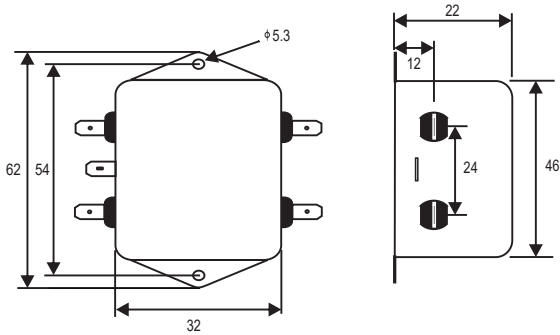

CONNECTION TYPE -1
10A to 12A

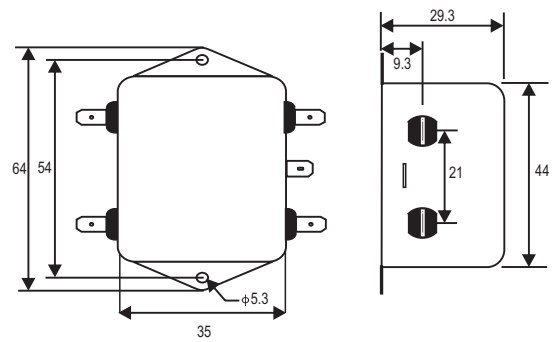

CONNECTION TYPE -1
16A

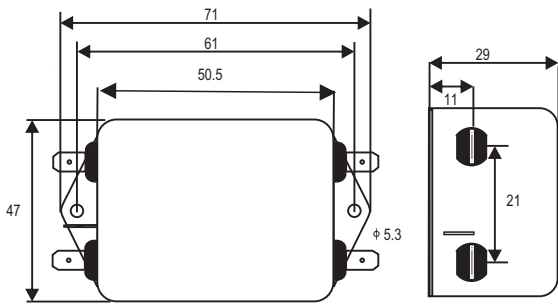

CONNECTION TYPE -3
16A

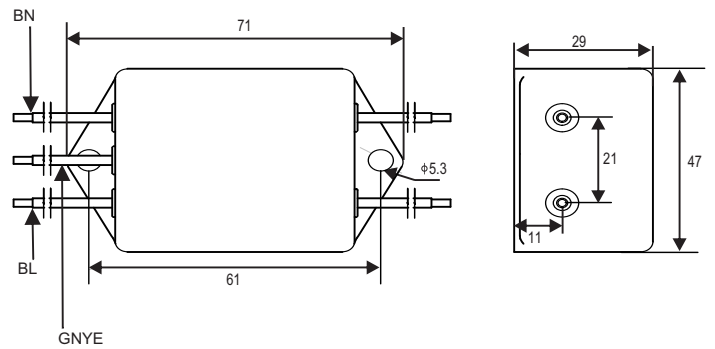

CONNECTION TYPE -1
20A

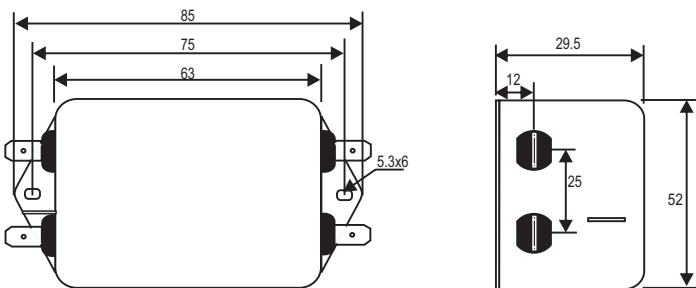

CONNECTION TYPE -6
30A

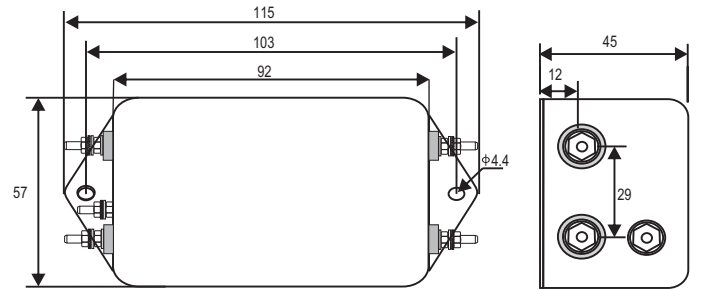

CONNECTION TYPE -6
60A

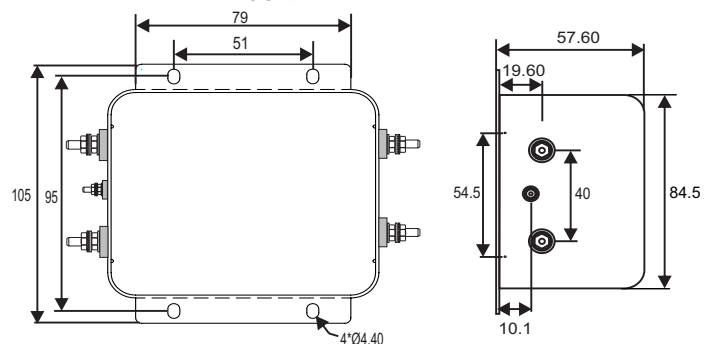

NOTE:

All Dimension in mm

- Connection type: 1 - Spade Terminals (6.3 x 0.8)
- 3 - Wire leads (140mm on both sides)
- 6 - Threaded Bolt Terminals (M4)