

Critical Conduction Mode PFC Control IC SSC2006SA

Data Sheet

Description

SSC2006SA is a Critical Conduction Mode (CRM) control IC for power factor correction (PFC).

Since no input voltage sensing is required, the IC allows the realization of low standby power and the low number of external components. The product achieves high cost-performance and high efficiency PFC converter system.

Package

SOP8

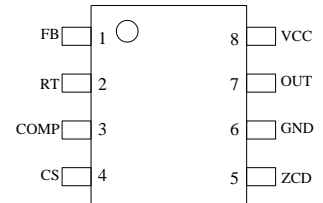

Not to Scale

Features

- Low Standby Power
(No input voltage sensing required)
- Minimum On-time Limitation Function
- Restart Function
- Protections
 - Overcurrent Protection (OCP) : Pulse-by-pulse
 - Overvoltage Protection (OVP) : Auto-restart
 - FB Pin Undervoltage Protection (FB_UVP) : Auto-restart
 - Thermal Shutdown Protection with hysteresis (TSD) : Auto-restart

Electrical Characteristics

- VCC pin absolute maximum ratings, $V_{CC} = 28\text{ V}$
- OUT pin source current, $I_{OUT(SRC)} = -500\text{ mA}$
- OUT pin sink current, $I_{OUT(SNK)} = 1000\text{ mA}$

Application

PFC circuit up to 200 W of output power such as:

- AC/DC Power Supply
- Digital appliances (large size LCD television and so forth).
- OA equipment (Computer, Server, Monitor, and so forth).
- Communication facilities
- Other SMPS

Typical Application Circuit

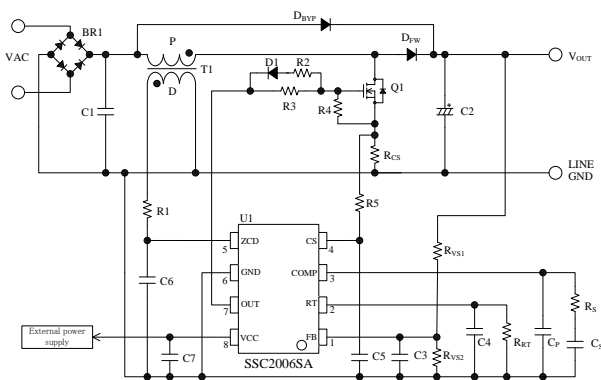

TC_SSC2006SA_1_R1

CONTENTS

Description	1
CONTENTS	2
1. Absolute Maximum Ratings	3
2. Electrical Characteristics	3
3. Block Diagram	5
4. Pin Configuration Definitions	5
5. Typical Application	6
6. External Dimensions	7
7. Marking Diagram	7
8. Operational Description	8
8.1 Critical Conduction Mode: CRM	8
8.2 Startup Operation	9
8.2.1 To Use an External Power Supply	9
8.2.2 To Use an Auxiliary Winding	9
8.3 Restart Circuit	10
8.4 Maximum On-time Setting	10
8.5 Zero Current Detection and Bottom-on Timing Setting	10
8.6 Overcurrent Protection (OCP)	11
8.7 Overvoltage Protection (OVP)	11
8.8 FB Pin Under Voltage Protection (FB_UVP)	12
8.9 Thermal Shutdown (TSD)	12
9. Design Notes	12
9.1 Inductor Design	12
9.1.1 Boost winding P	12
9.1.2 Auxiliary Winding D	13
9.2 External Components	14
9.2.1 FB Pin Peripheral Circuit (Output Voltage Detection)	14
9.2.2 RT Pin Peripheral Circuit, R_{RT} and C4	14
9.2.3 COMP Pin Peripheral Circuit, R_S , C_S and C_P	15
9.2.4 CS Pin Peripheral Circuit, R_{CS} , R5 and C5	15
9.2.5 ZCD Pin Peripheral Circuit, R1 and C6	15
9.2.6 OUT Pin Peripheral Circuit (Gate Drive Circuit)	16
9.2.7 VCC Pin Peripheral Circuit	16
9.2.8 Power MOSFET, Q1	17
9.2.9 Boost Diode, D_{FW}	17
9.2.10 Bypass Diode, D_{BYP}	17
9.2.11 Output Capacitor, C2	17
9.3 PCB Trace Layout and Component Placement	18
10. Reference Design of Power Supply	20
OPERATING PRECAUTIONS	22
IMPORTANT NOTES	23

1. Absolute Maximum Ratings

- The polarity value for current specifies a sink as “+”, and a source as “-”, referencing the IC.
- Unless specifically noted $T_A = 25\text{ }^\circ\text{C}$

Parameter	Symbol	Conditions	Pins	Rating	Unit	Note
FB Pin Voltage	V_{FB}		1 – 6	- 0.3 to 5	V	
RT Pin Current	I_{RT}		2 – 6	- 500 to 0	μA	
COMP Pin Current	I_{COMP}		3 – 6	- 100 to 100	μA	
CS Pin Voltage	V_{CS}		4 – 6	- 0.3 to 5	V	
ZCD Pin Current	I_{ZCD}		5 – 6	- 10 to 10	mA	
OUT Pin Source Current	$I_{OUT(SRC)}$		7 – 6	- 500	mA	
OUT Pin Sink Current	$I_{OUT(SNK)}$		7 – 6	1000	mA	
VCC Pin Voltage	V_{CC}		8 – 6	28	V	
Allowable Power Dissipation	P_D		-	0.5	W	
Operating Ambient Temperature	T_{OP}		-	- 40 to 110	$^\circ\text{C}$	
Storage Temperature	T_{stg}		-	- 40 to 150	$^\circ\text{C}$	
Junction Temperature	T_j		-	150	$^\circ\text{C}$	

2. Electrical Characteristics

- The polarity value for current specifies a sink as “+”, and a source as “-”, referencing the IC.
- Unless specifically noted, $T_A = 25\text{ }^\circ\text{C}$, $V_{CC} = 14\text{ V}$

Parameter	Symbol	Conditions	Pins	Min.	Typ.	Max.	Unit
Power Supply Operation							
Operation Start Voltage	$V_{CC(ON)}$		8 – 6	10.5	12.0	13.5	V
Operation Stop Voltage	$V_{CC(OFF)}$		8 – 6	8.2	9.5	11.0	V
Operation Voltage Hysteresis	$V_{CC(HYS)}$		8 – 6	1.4	2.5	3.1	V
Circuit Current in Operation	$I_{CC(ON)}$		8 – 6	2.0	2.9	4.4	mA
Circuit Current in Non-Operation	$I_{CC(OFF)}$	$V_{CC} = 9.5\text{ V}$	8 – 6	40	80	160	μA
Oscillation Operation							
Maximum On-Time	$t_{ON(MAX)}$	$V_{FB} = 1.5\text{ V}$ $R_{RT} = 22\text{ k}\Omega$	7 – 6	15	23	33	μs
RT Pin Voltage	V_{RT}		2 – 6	1.3	1.5	1.7	V
Feedback Control Voltage	V_{FB}		1 – 6	2.46	2.50	2.54	V
Feedback Line Regulation	$V_{FB(LR)}$		1 – 6	- 8.0	1.0	12.0	mV
FB Pin Bias Current	I_{FB}		1 – 6	- 3.2	- 2.0	- 1.0	μA
Error Amplifier Transconductance Gain	gm		1 – 6 3 – 6	60	103	150	μS
COMP Pin Sink Current	$I_{COMP(SNK)}$		3 – 6	18	40	72	μA
COMP Pin Source Current	$I_{COMP(SRC)}$		3 – 6	- 72	- 40	- 18	μA
Zero Duty COMP Voltage	$V_{COMP(ZD)}$		3 – 6	0.50	0.65	0.90	V

SSC2006SA

Parameter	Symbol	Conditions	Pins	Min.	Typ.	Max.	Unit
Restart Time	t_{RS}		–	90	170	250	μs
Drive Output							
Output Voltage (High)	V_{OH}	$I_{OUT} = -100 \text{ mA}$	7 – 6	10.0	12.0	13.5	V
Output Voltage (low)	V_{OL}	$I_{OUT} = 200 \text{ mA}$	7 – 6	0.40	0.75	1.25	V
Output Rise Time ⁽¹⁾	t_r	$C_{OUT} = 1000 \text{ pF}$	7 – 6	–	60	120	ns
Output Fall Time ⁽¹⁾	t_f	$C_{OUT} = 1000 \text{ pF}$	7 – 6	–	20	70	ns
Zero Current Detection							
Zero Current Detection Threshold Voltage (High)	$V_{ZCD(H)}$		5 – 6	1.3	1.5	1.7	V
Zero Current Detection Threshold Voltage (Low)	$V_{ZCD(L)}$		5 – 6	0.60	0.75	0.90	V
Zero Current Detection Delay Time ⁽²⁾	$t_{DLY(ZCD)}$		5 – 6	100	200	350	μs
Overcurrent Protection							
Overcurrent Protection Threshold Voltage	$V_{CS(OC)}$		4 – 6	0.66	0.72	0.78	V
Overcurrent Protection Delay Time ⁽²⁾	$t_{DLY(OC)}$		4 – 6	200	350	500	ns
CS Pin Source Current	I_{CS}		4 – 6	– 120	– 60	– 30	μA
FB Pin Protection							
Overvoltage Protection Threshold Voltage	V_{OVP}		1 – 6	$1.075 \times V_{FB}$	$1.090 \times V_{FB}$	$1.105 \times V_{FB}$	V
Overvoltage Protection Hysteresis	$V_{OVP(HYS)}$		1 – 6	55	90	125	mV
Undervoltage Protection Threshold Voltage	V_{UVP}		1 – 6	200	300	400	mV
Undervoltage Protection Hysteresis	$V_{UVP(HYS)}$		1 – 6	80	120	160	mV
Thermal Shutdown							
Thermal Shutdown Threshold ⁽²⁾	$T_{j(TSD)}$		–	135	150	–	$^{\circ}C$
Thermal Shutdown Hysteresis ⁽²⁾	$T_{j(TSDHYS)}$		–	–	10	–	$^{\circ}C$
Thermal Resistance							
Junction to Ambient Resistance ⁽²⁾	θ_{j-A}		–	–	–	180	$^{\circ}C/W$

⁽¹⁾ Shown in Figure 2

⁽²⁾ Design assurance item

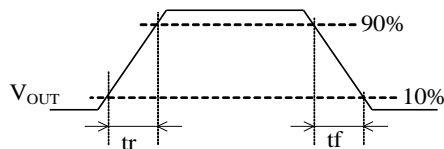
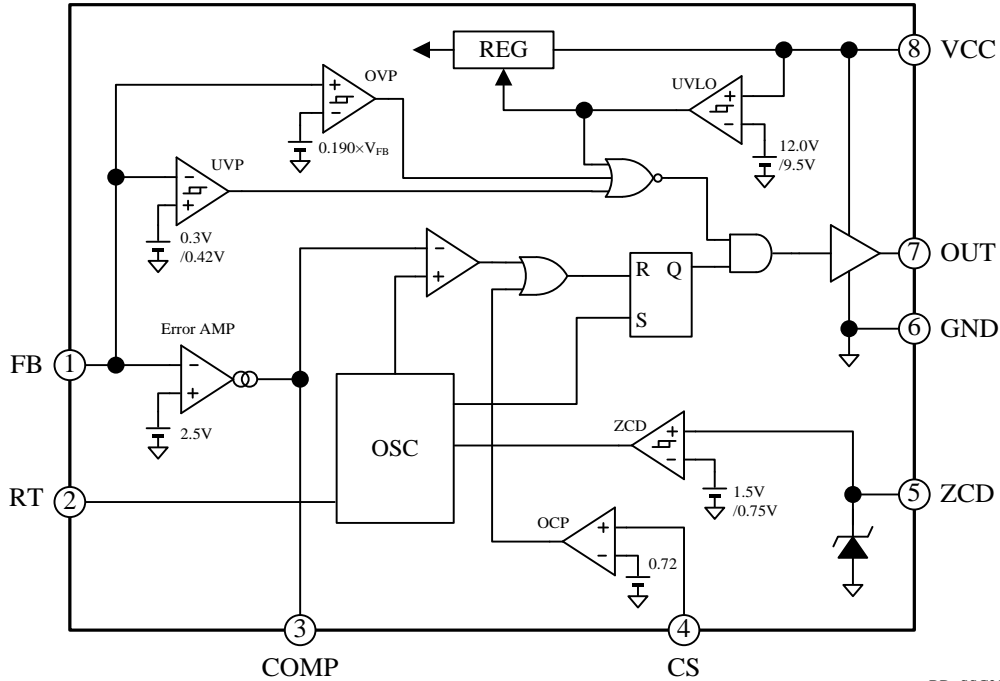

Figure 2 Switching time

3. Block Diagram



BD_SSC2006SA_R1

4. Pin Configuration Definitions

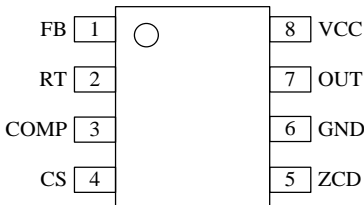

Number	Name	Function
1	FB	Feedback signal input, Overvoltage Protection signal input and FB pin Undervoltage Protection signal input
2	RT	Maximum on-time adjustment
3	COMP	Phase compensation
4	CS	Overcurrent Protection signal input
5	ZCD	Zero current detection signal input and bottom-on-timing adjustment
6	GND	Ground
7	OUT	Gate drive output
8	VCC	Power supply input for control circuit

6. External Dimensions

SOP8

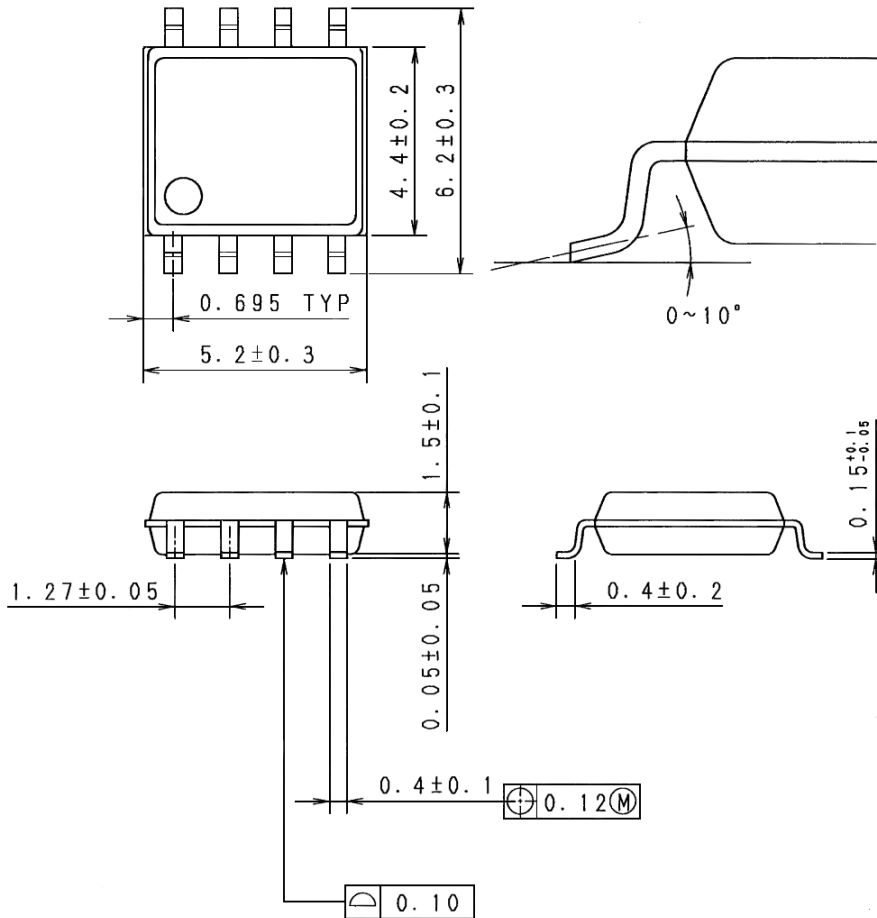

NOTES:

- 1) All linear dimensions are in millimeters
- 2) Pb-free. Device composition compliant with the RoHS directive.

7. Marking Diagram

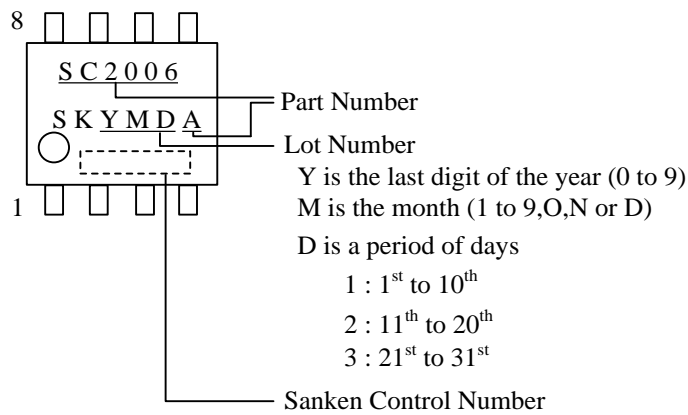

8. Operational Description

All of the parameter values used in these descriptions are typical values, unless they are specified as minimum or maximum.

With regard to current direction, "+" indicates sink current (toward the IC) and "-" indicates source current (from the IC).

8.1 Critical Conduction Mode: CRM

Figure 8-1 and Figure 8-2 show the PFC circuit and CRM operation waveform. The IC performs the on/off operation of switching device Q1 in critical mode (the inductor current is zero). Thus, the low drain current variation di/dt of power MOSFET is accomplished. Also, adjusting the turn-on timing at the bottom point of V_{DS} free oscillation waveform (quasi-resonant operation), low noise and high efficiency PFC circuit is realized.

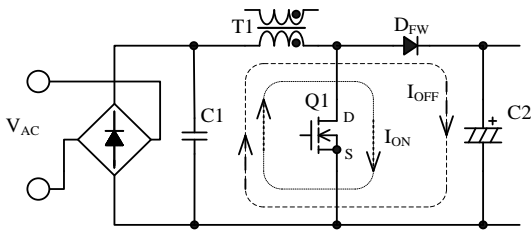

Figure 8-1 PFC circuit

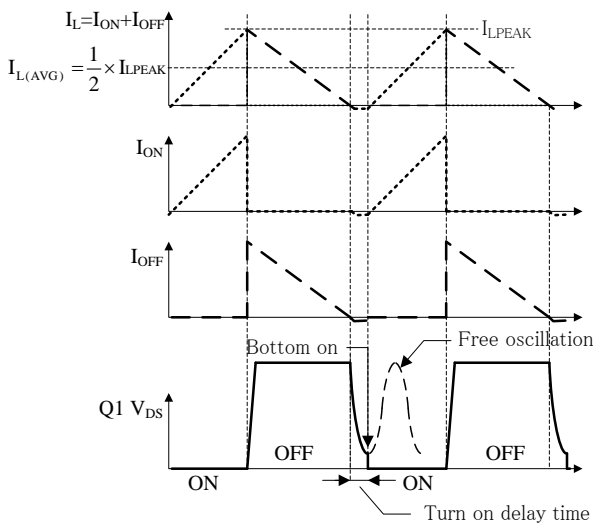

Figure 8-2 CRM operation and bottom on operation

Figure 8-3 shows the internal CRM control circuit.

The power MOSFET Q1 starts switching operation by

self-oscillation.

The on-time control is as follows: the detection voltage R_{VS2} is compared with the Feedback Control Voltage $V_{FB} = 2.50 \text{ V}$ by using error amplifier (Error AMP) connected to FB pin. The output of the Error AMP is averaged and the phase is compensated. This signal V_{COMP} is compared with the ramp signal V_{OSC} to achieve the on-time control. The on-time becomes almost constant in commercial cycle by setting V_{COMP} to respond below 20 Hz (Figure 8-4). This is achieved by tuning the capacitor connected to COMP pin.

The off-time is set by detecting the zero current signal of boost winding P. The zero current is detected by auxiliary winding D and ZCD pin.

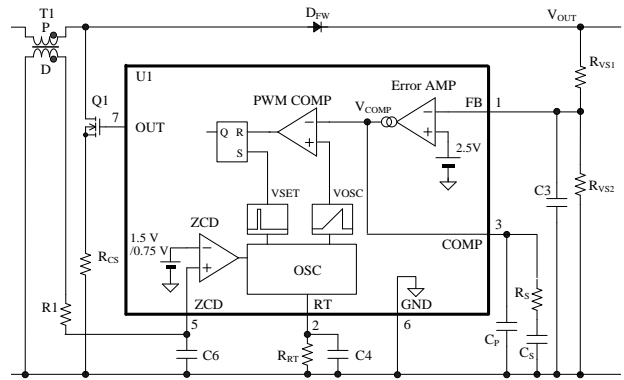

Figure 8-3 CRM control circuit

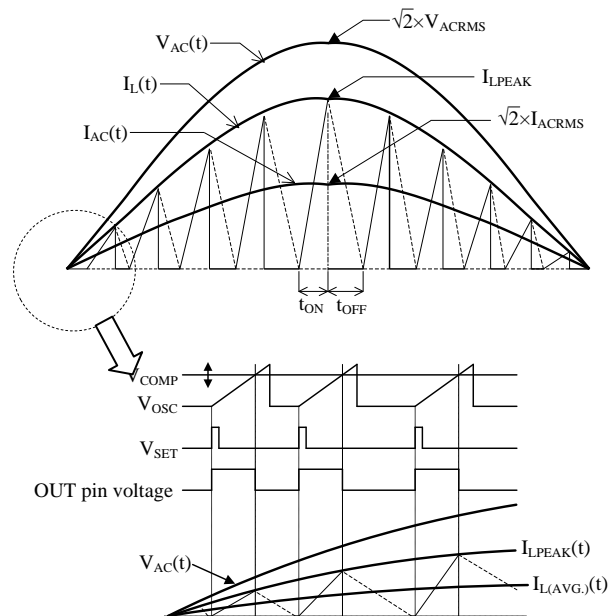

Figure 8-4 CRM operation waveforms

The off duty D_{OFF} of boost converter in CRM mode have the relation of $D_{OFF}(t) = V_{AC}(t)/V_{OUT}$ and is proportional to input voltage, where $V_{AC}(t)$ is the input voltage of AC line as a function of time.

As a result of aforementioned control shown in Figure 8-4, the peak current I_{LPEAK} of the inductance current I_L becomes sinusoidal. Since the averaged input current become similar to AC input voltage waveform by Low Pass Filter at input stage, high power factor is achieved.

8.2 Startup Operation

Figure 8-5 and Figure 8-7 show the VCC pin peripheral circuit. Figure 8-5 shows how to use an external power supply. Figure 8-7 shows how to use an auxiliary winding.

8.2.1 To Use an External Power Supply

When an external power supply shown in Figure 8-5 is used, the startup operation is as follows.

As shown in Figure 8-6, when VCC pin voltage rises to the Operation Start Voltage $V_{CC(ON)} = 12.0\text{ V}$, the control circuit starts operation and the COMP pin voltage increases. The COMP pin voltage increases to the Zero Duty COMP Voltage $V_{COMP(ZD)} = 0.65\text{ V}$, switching operation starts.

When the VCC pin voltage decreases to $V_{CC(OFF)} = 9.5\text{ V}$, the control circuit stops operation by Undervoltage Lockout (UVLO) circuit, and reverts to the state before startup.

Since the COMP pin voltage rises from zero during startup period, the V_{COMP} signal shown in Figure 8-3 gradually rises from low voltage. The on-width gradually increased to restrict the rise of output power by the Softstart Function. Thus, the stress of the peripheral component is reduced.

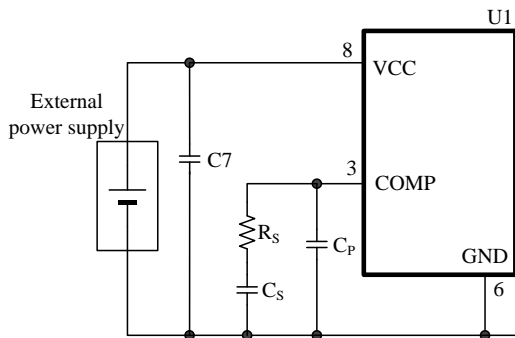

Figure 8-5 VCC pin peripheral circuit (Power supply from external power supply)

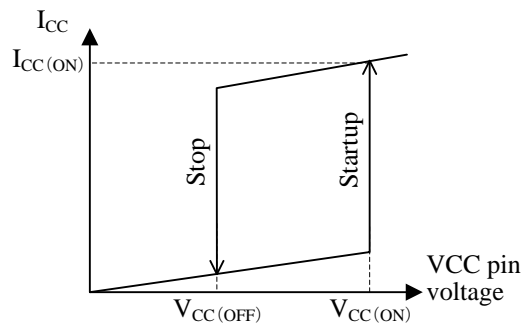

Figure 8-6 Relationship between VCC pin voltage and I_{CC}

8.2.2 To Use an Auxiliary Winding

When an auxiliary winding is used as shown in Figure 8-7, C_{VCC} is charged through R_{ST} at startup. When VCC pin voltage rises to $V_{CC(ON)} = 12.0\text{ V}$, the control circuit starts operation.

Figure 8-8 shows the VCC pin voltage behavior during startup period.

When the VCC pin voltage reaches $V_{CC(ON)}$, the control circuit starts operation. Then the circuit current increases and the VCC pin voltage decreases. At the same time, the auxiliary winding voltage V_D increases in proportion to the output voltage. These are all balanced to produce VCC pin voltage.

The value of C_{VCC} , the turns ratio of boost winding P and auxiliary winding D should be set so that VCC pin voltage is maintained higher than $V_{CC(OFF)} = 9.5\text{ V}$ (Refer to Section 9.1).

If the values of R_{ST} and C_{VCC} are large, the startup time becomes longer. Adjustment is necessary in actual operation.

When the COMP pin voltage increases to the Zero Duty COMP Voltage $V_{COMP(ZD)} = 0.65\text{ V}$ after the control circuit starts operation, switching operation starts and the circuit current is supplied from auxiliary winding D as follows.

V_B and V_D are the voltage of auxiliary winding during Q1 on and off, respectively.

When Q1 is on, C_{CP} is charged by V_B . When Q1 is off, the capacitor connected to VCC pin, C_{VCC} , is charged by $V_D + V_B (=V_{CCP})$.

V_B is calculated using Equation (1).

$$V_B = V_{IN} \times \frac{N_D}{N_P} \quad (1)$$

Where,

V_{IN} : C1 voltage (V)

N_P : Number of turns of boost winding P (turns)

N_D : Number of turns of auxiliary winding D (turns)

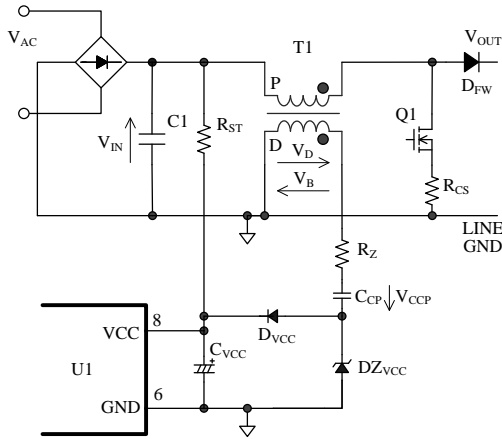

Figure 8-7 VCC pin peripheral circuit (Power supply from auxiliary winding)

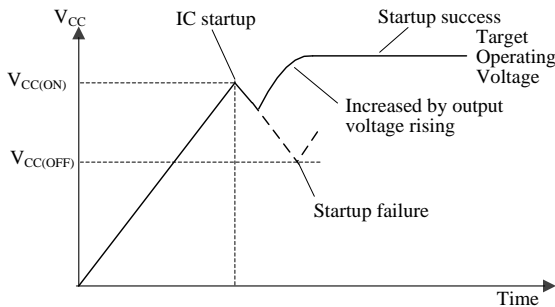

Figure 8-8 VCC during startup period

8.3 Restart Circuit

The IC is self-oscillation type. The off-time of OUT pin is set by the detecting zero current signal at ZCD pin.

When the off-time of OUT pin is maintained for $t_{RS} = 170 \mu s$ or more, the restart circuit is activated and OUT pin turns on.

At intermittent oscillation period in startup and light load, the restart circuit is activated and the switching operation is stabilized.

Since $t_{RS} = 170 \mu s$ corresponds to the operational frequency of 5.9 kHz, the minimum frequency should be set to higher than 20 kHz (above audible frequency) at the inductance value design.

8.4 Maximum On-time Setting

In order to reduce audible noise of transformer at transient state, the IC has the Maximum on-time, $t_{ON(MAX)}$. This $t_{ON(MAX)}$ is adjusted by the resistance R_{RT} that is connected to RT pin.

Figure 8-9 shows the relation between R_{RT} value and

$t_{ON(MAX)}$ in IC design. The $t_{ON(MAX)}$ is made into a larger value than $t_{ON(SET)MAX}$ that is result of Equation (4) in Section 9.1.

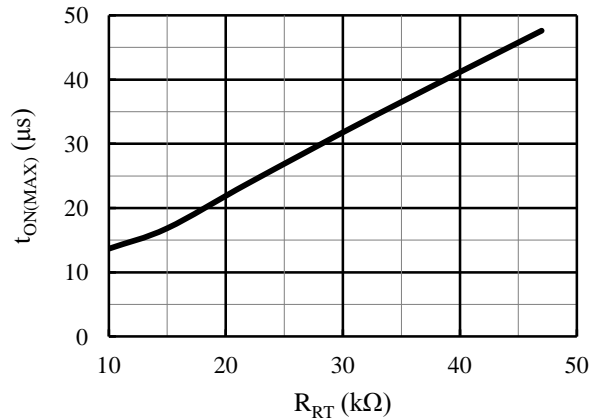

Figure 8-9 Relationship between R_{RT} value and $t_{ON(MAX)}$ value (IC design)

8.5 Zero Current Detection and Bottom-on Timing Setting

Figure 8-10 shows the peripheral circuit of ZCD pin, Figure 8-11 shows the zero current detection waveform.

The off-time is determined by detecting the zero current of the boost winding P via the auxiliary winding D and ZCD pin. The polarity of winding P and winding D of transformer T1 are shown in Figure 8-10.

When the OUT pin voltage becomes low and the power MOSFET turns off, the ZCD pin voltage becomes the voltage of auxiliary winding D as shown in Figure 8-11. After the turning off of the power MOSFET, when ZCD pin voltage is above $V_{ZCD(H)} = 1.5 V$, OUT pin voltage is kept to be Low. When ZCD pin voltage becomes below $V_{ZCD(L)} = 0.75 V$, OUT pin voltage becomes High and power MOSFET turns on.

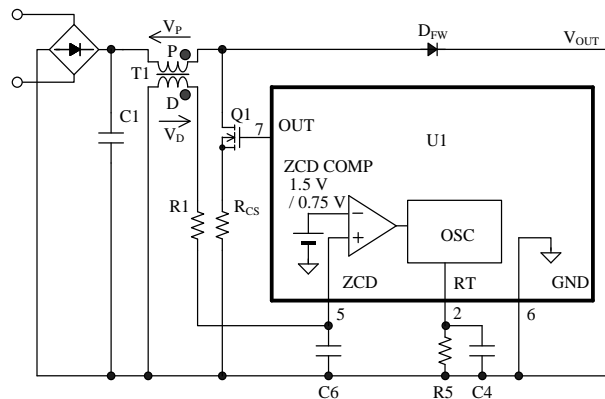

Figure 8-10 ZCD pin peripheral circuit

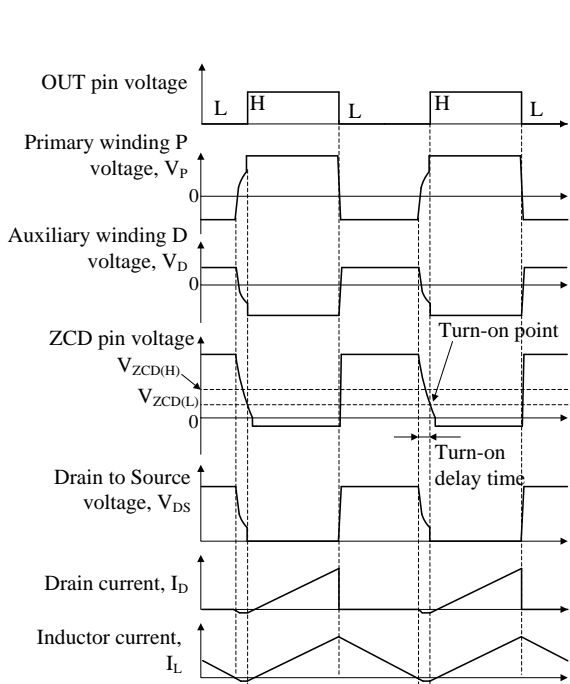

Figure 8-11 Zero current detection waveform

After the turning off of the power MOSFET, when the current in boost winding become zero, V_{DS} waveform starts free oscillation based on the inductance L_p , the output capacitance of power MOSFET C_{OSS} and the parasitic capacitance. The bottom point of V_{DS} is calculated as follows:

$$t_{HFP} \doteq \pi \times \sqrt{L_p \times C_v} \quad (2)$$

Where,

- t_{HFP} : Half cycle of free oscillation (s)
- L_p : Inductance of boost winding (H)
- C_v : Combined output capacitance of power MOSFET C_{OSS} and parasitic capacitanc (F)

In order to set the timing of turn on to the bottom point of V_{DS} as shown in Figure 8-12, adjust the turn on delay time t_{HFP} by using C6 and R1 in actual operation codition as shown in Figure 8-10. Since R1 have a role as the current limiting resistor of ZCD pin, adjust the C6 value if R1 value exceeds the range of limiting.

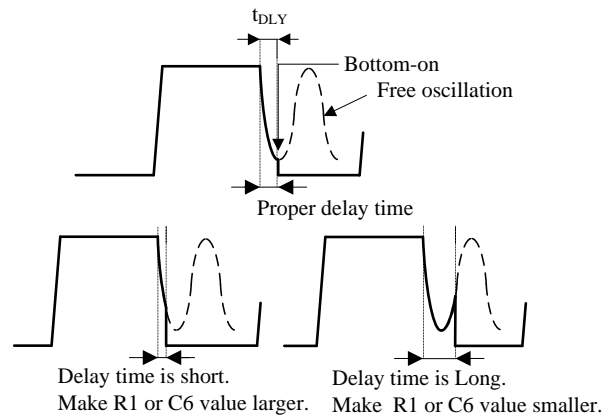

Figure 8-12 V_{DS} turn on timing

8.6 Overcurrent Protection (OCP)

Figure 8-13 shows the CS pin peripheral circuit and internal circuit. The inductor current, I_L is detected by the detection resistor, R_{CS} . The detection voltage, V_{RCS} , is fed into CS pin. When V_{RCS} increases $V_{CS(OCP)} = 0.72$ V or more, the output of out pin becomes Low by pulse-by-pulse.

As shown in Figure 8-13, the CS pin is connected to capacitor-resistor filter (R5 and C5).

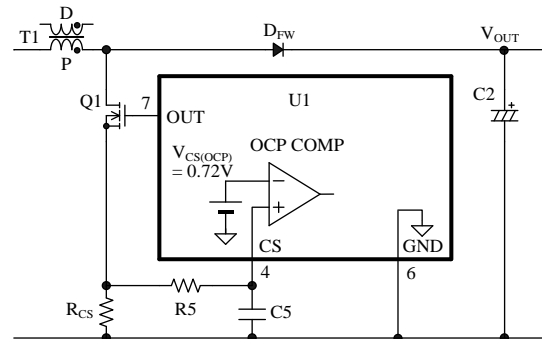

Figure 8-13 The CS pin peripheral circuit and internal circuit.

8.7 Overvoltage Protection (OVP)

Figure 8-14 shows the waveforms of Overvoltage Protection (OVP) operation.

When the FB pin voltage increase to Overvoltage Protection Threshold Voltage, V_{OVP} , OUT pin voltage become Low immediatly and the switching operation stops. As a result, the rise of output voltage is prevented. V_{OVP} is 1.090 times the Feedback Control Voltage, $V_{FB} = 2.50$ V. When the cause of the overvoltage is removed and FB pin voltage decreases to $V_{OVP} - V_{OVP(HYS)}$ the switching operation restarts.

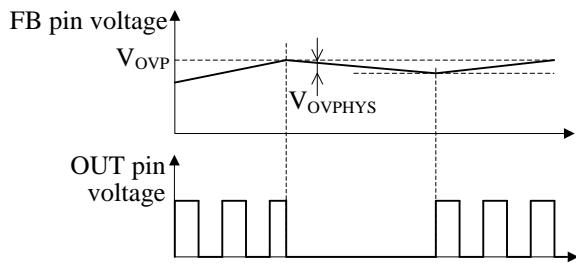

Figure 8-14 OVP waveforms

8.8 FB Pin Under Voltage Protection (FB_UVP)

FB Pin Under Voltage Protection (FB_UVP) is activated when the FB pin voltage is decreased by the malfunctions in feedback loop such as the open of R_{VS1} or the short of R_{VS2} .

Figure 8-15 shows the FB pin peripheral circuit and internal circuit. When the FB pin voltage is decreased to $V_{UVP} = 300\text{ mV}$ or less, the OUT pin output is turned-off immediately and switching operation stops. This prevents the rise of output voltage. When the cause of malfunction is removed and the FB pin voltage rises to $V_{UVP} + V_{UVP(HYS)}$, the switching operation restarts.

In case the FB pin is open, the FB pin voltage is increase and OVP is activated as described in Section 8.6.

When the cause of malfunction is removed and the IC becomes normal control, the switching operation restarts.

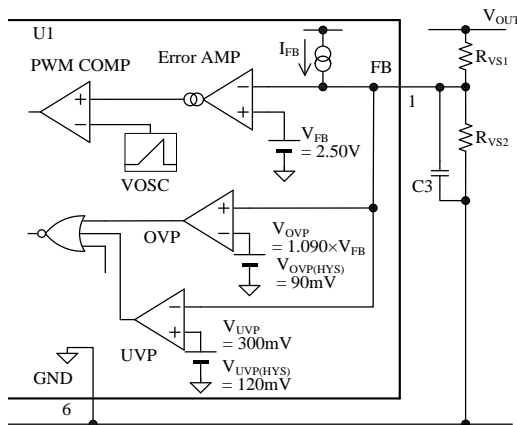

Figure 8-15 The FB pin peripheral circuit and internal circuit.

8.9 Thermal Shutdown (TSD)

< Using External Power Supply >

When the temperature of control circuit increases to $T_{j(TSD)} = 150\text{ }^\circ\text{C}$ or more, Thermal Shutdown (TSD) is

activated and the IC stops switching operation.

When the fault condition is removed and the temperature decreases to less than $T_{j(TSD)} - T_{j(TSDHYS)}$, the IC returns to normal operation automatically.

< Using Auxiliary Winding D for VCC supply >

When TSD is activated and the IC stops switching operation, VCC pin voltage decreases to $V_{CC(OFF)}$ and the control circuit stops operation. After that, the IC reverts to the initial state by UVLO circuit, and the IC starts operation when VCC pin voltage increases to $V_{CC(ON)}$ by startup current. Thus the intermittent operation by UVLO is repeated in TSD state.

When the fault condition is removed and the temperature decreases to less than $T_{j(TSD)} - T_{j(TSDHYS)}$, the IC returns to normal operation automatically.

9. Design Notes

9.1 Inductor Design

Inductor T1 consists of a boost winding P and auxiliary winding D. The winding P is used for boosting the voltage and winding D is used for off-timing detection.

The calculation methods of winding P and winding D are as shown below. Since the following calculating formulas are approximated, the peak current and the frequency of operational waveforms may be different from the setting value at calculating. Eventually, the inductance value should be adjusted in actual operation.

Apply proper design margin to temperature rise by core loss and copper loss.

9.1.1 Boost winding P

Inductance L_P of PFC in CRM mode is calculated as follows:

1) Output Voltage, V_{OUT}

The output voltage V_{OUT} of boost-converter should be set higher than peak value of input voltage as following equation:

$$V_{OUT} \geq \sqrt{2} \times V_{ACRMS(MAX)} + V_{DIF} \quad (V) \quad (3)$$

where,

$V_{ACRMS(MAX)}$: Maximum AC input voltage rms value (V)
 V_{DIF} : Boost voltage (about 10V) (V)

2) Operational Frequency, $f_{SW(SET)}$ and Maximum On-time, $t_{ON(SET)MAX}$

Determine $f_{SW(SET)}$ that is minimum operational frequency at the peak of the AC line waveform. The

frequency becomes higher with lowering the input voltage. The frequency at the peak of the AC line waveform, $f_{SW(SET)}$ should be set more than frequency of 20 kHz.

The $t_{ON(SET)MAX}$ at $f_{SW(SET)}$ is calculated by Equation (4). The $t_{ON(MAX)}$ described in “8.4 Maximum on-time setting” should be set above $t_{ON(SET)MAX}$.

$$t_{ON(SET)MAX} = \frac{V_{OUT} - \sqrt{2} \times V_{ACRMS(MIN)}}{f_{SW(SET)} \times V_{OUT}} \quad (s) \quad (4)$$

where,

V_{OUT} : Output voltage (V)

$V_{ACRMS(MIN)}$: Maximum AC input voltage rms value (V)

3) Inductance, L_p

Substituting both minimum and maximum of AC input voltage to V_{ACRMS} , choose a smaller one as L_p value. L_p is calculated as follows:

$$L_p = \frac{\eta \times (V_{ACRMS})^2 \times (V_{OUT} - \sqrt{2} \times V_{ACRMS})}{2 \times P_{OUT} \times f_{SW(SET)} \times V_{OUT}} \quad (H) \quad (5)$$

where,

V_{ACRMS} : Maximum or minimum AC input voltage rms value (V)

P_{OUT} : Output Power (W)

$f_{SW(SET)}$: Minimum operational frequency at the peak of the AC line waveform (kHz)

η : Efficiency of PFC

(In general, the range of η is 0.90 to 0.97, depending on on-resistance of power MOSFET $R_{DS(ON)}$ and forward voltage drop of rectifier diode V_F .)

4) Inductor peak current, I_{LP}

I_{LP} is peak current at the minimum of AC input voltage waveform. I_{LP} calculated as follows:

$$I_{LP} = \frac{2 \times \sqrt{2} \times P_{OUT}}{\eta \times V_{ACRMS(MIN)}} \quad (A) \quad (6)$$

9.1.2 Auxiliary Winding D

Figure 9-1 shows the polarity of boost winding P and auxiliary winding D.

Given the number of windings of each winding as N_p and N_D , the turn ratio N_D/N_p is set satisfying following conditions. The condition of N_D/N_p making ZCD pin voltage above $V_{ZCD(H)} = 1.5$ V after power MOSFET turns off is expressed as follows:

$$\frac{N_D}{N_P} > \frac{V_{ZCD(H)}}{V_{OUT} - \sqrt{2} \times V_{ACRMS(MAX)}} \quad (7)$$

where,

N_p : The number of turns of boost winding P (turns)

N_D : The number of turns of auxiliary winding D (turns)

V_{OUT} : Output voltage (V)

$V_{ACRMS(MAX)}$: Maximum AC input voltage rms value (turns)

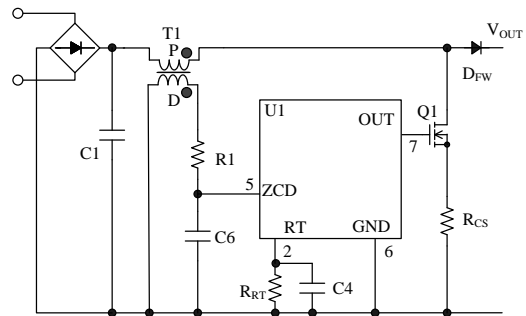

Figure 9-1 ZCD Peripheral circuit

When power supply of VCC pin is supplied from auxiliary winding as shown in Figure 9-2, the condition of N_D/N_p is necessary to satisfy both Equation (7) and following Equation (11).

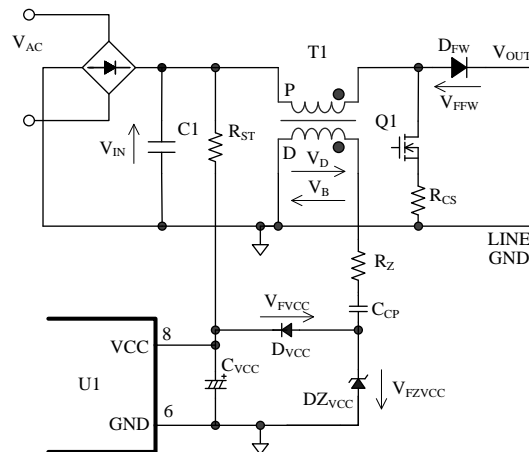

Figure 9-2 VCC pin peripheral circuit (Power supply from auxiliary winding)

When switching operation starts, the current is supplied by auxiliary winding as follows:

Auxiliary winding voltage in ON state and OFF state of Q1 are given as V_B and V_D , respectively. The forward voltages of Diode (DZ_{VCC} and D_{VCC}) are given as V_{FZVCC} and V_{FVCC} .

$t_{ON(MAX)}$. The value of R_{RT} is set using Figure 8-9 and should be selected so that $t_{ON(MAX)}$ is more than $t_{ON(SET)MAX}$ of Equation (3).

R_{RT} is about 15 kΩ to 47 kΩ. If R_{RT} is out of the range, it is necessary that the setting value of $f_{SW(SET)}$ in Equation (5) is adjusted and the value of L_P is calculated again.

9.2.3 COMP Pin Peripheral Circuit, R_S , C_S and C_P

The FB pin voltage is induced into internal Error AMP. The output voltage of the Error AMP is averaged by the COMP pin. The on-time control is achieved by comparing the signal V_{COMP} and the ramp signal V_{OSC} . C_S and R_S adjust the response speed of changing on-time according to output power.

The typical value of C_S and R_S are 1 μF and 68 kΩ, respectively. When C_S value is too large, the response becomes slow at dynamic variation of output and the output voltage decreases.

Since C_S and R_S affect on the soft-start period at startup, adjustment is necessary in actual operation.

The ripple of output detection signal is averaged by C_P . When the C_P value is too small, the IC operation may become unstable due to the output ripple. The value of capacitor C_P is approximately 0.47 μF.

9.2.4 CS Pin Peripheral Circuit, R_{CS} , R_5 and C_5

R_{CS} shown in Figure 9-3 is current sensing resistor. R_{CS} is the resistor for the current detection. A high frequency switching current flows to R_{CS} , and may cause poor operation if a high inductance resistor is used. Choose a low inductance and high surge-tolerant type. R_{CS} is calculated using the following Equation (13), where Overcurrent Protection Threshold Voltage $V_{CS(OC)}$ is 0.72 V and I_{LP} is calculated using Equation (6).

$$R_{CS} \leq \frac{|V_{CS(OC)}|}{I_{LP}} \quad (\Omega) \quad (13)$$

The loss P_{RCS} at R_{CS} is calculated by Equation (15) using Equation (14).

$$I_{DRMS} = \frac{2 \times \sqrt{2} \times P_{OUT}}{\eta \times V_{ACRMS(MIN)}} \times \sqrt{\frac{1}{6} - \frac{4 \times \sqrt{2} \times V_{ACRMS(MIN)}}{9 \times \pi \times V_{OUT}}} \quad (A) \quad (14)$$

$$P_{RCS} = (I_{DRMS})^2 \times R_{CS} \quad (W) \quad (15)$$

Where,

I_{DRMS} : RMS Drain current (A)

$V_{ACRMS(MIN)}$: Minimum AC input voltage rms value (V)

V_{OUT} : Output voltage (V)

P_{OUT} : Output power (W)

η : Efficiency of PFC

The CR filter (R_5 and C_5) is connected to CS pin.

CR filter (R_5 and C_5) prevents IC from responding to the drain current surge at MOSFET turn-on and avoids the unstable operation of the IC.

R_5 value of approximately 47 Ω is recommended, since the CS Pin Source Current affects the accuracy of OCP detection (see Section 8.5).

C_5 value is recommended to be calculated by using following formula in which cut-off frequency of CR filter (C_5 and R_5) is approximately 1 MHz.

$$C_5 = \frac{1}{2 \times \pi \times 1 \times 10^6 \times R_5} \quad (F) \quad (16)$$

If R_5 value is 47 Ω, C_5 value is approximately 3300 pF.

9.2.5 ZCD Pin Peripheral Circuit, R_1 and C_6

R_1 is for the limiting of the input and output current to ZCD pin. The value of resistor R_1 is determined so that the ZCD pin current is smaller than the absolute maximum rating. The recommended value of ZCD pin current is less than 3 mA.

The R_1 value is chosen to satisfy both Equation (17) and Equation (18).

In addition, the bottom-on timing is set by C_6 and R_1 (Refer to Section 8.5).

(1) Limiting of ZCD pin source current (at Q1 ON state)

$$R_1 > \frac{\sqrt{2} \times V_{ACRMS(MAX)} \times \frac{N_D}{N_P}}{3 \times 10^{-3} (A)} \quad (\Omega) \quad (17)$$

Where,

$V_{ACRMS(MAX)}$: Maximum AC input voltage rms value (V)

N_P : The number of turns of boost winding P (turns)

N_D : The number of turns of auxiliary winding D (turns)

(2) Limiting of ZCD pin sink current (at Q1 OFF state)

$$R1 > \frac{V_{OUT} \times \frac{N_D}{N_P} - 5(V)}{3 \times 10^{-3}(A)} \quad (\Omega) \quad (18)$$

Where,

V_{OUT} : Output voltage (V)

N_P : The number of turns of boost winding P (turns)

N_D : The number of turns of auxiliary winding D (turns)

5 V is zener voltage of internal zener diode connecting to ZCD pin.

9.2.6 OUT Pin Peripheral Circuit (Gate Drive Circuit)

The OUT pin is the gate drive output that can drive the external power MOSFET directly.

The maximum output voltage of OUT pin is the VCC pin voltage. The maximum current is -500 mA for source and 1000 mA for sink, respectively.

R3 is for source current limiting. Both R2 and D1 are for sink current limiting. The values of these components are adjusted to decrease the ringing of Gate pin voltage and the EMI noise. The reference value is several ohms to several dozen ohms.

R4 is used to prevent malfunctions due to steep dv/dt at turn-off of the power MOSFET, and the resistor is connected near the MOSFET, between the gate and source. The reference value of R4 is from 10 kΩ to 100 kΩ.

R2, R3, D1 and R4 are affected by the printed circuit board trace layout and the power MOSFET capacitance. Thus, the optimal values should be adjusted under actual operation of the application.

9.2.7 VCC Pin Peripheral Circuit

< Using External Power Supply >

Figure 9-4 shows the VCC pin peripheral circuit. The value of capacitor C7 is set approximately 1000 pF, in order to reduce the switching noise.

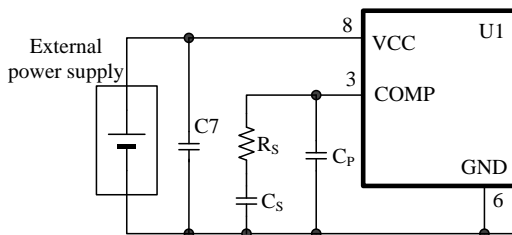

Figure 9-4 VCC pin peripheral circuit (Power supply from external power supply)

< Using Auxiliary Winding D for VCC supply >

Figure 9-5 shows the VCC pin peripheral circuit when VCC pin is supplied from auxiliary winding.

• **R_{ST}**

The value of startup resistor, R_{ST} is selected so that the current more than I_{CC(OFF)} = 160 μA (max.) can be supplied to VCC pin at startup.

R_{ST} is expressed as follows:

$$R_{ST} < \frac{\sqrt{2} \times V_{ACRMS(MIN)} - V_{CC(ON)(MAX)}}{I_{CC(OFF)(MAX)}} \quad (\Omega) \quad (19)$$

Where, V_{ACRMS(MIN)} is minimum AC input voltage rms value (V)

When the specification of AC input voltage is 100 V or Universal, the value of R_{ST} is approximately 100 kΩ to 220 kΩ. When the specification of AC input voltage is 230 V, the value of R_{ST} is approximately 180 kΩ to 330 kΩ.

The rating of R_{ST} is chosen taking into account the loss of R_{ST} at maximum input voltage. Since the high voltage is applied to resistor, choose a resistor designed against electromigration or use a series combination of resistors.

• **C_{VCC}**

The approximate startup time is determined by the value of C_{VCC}. It is calculated as follows where the initial voltage of VCC pin is zero.

$$t_{START} \doteq \frac{C7 \times V_{CC(ON)}}{\frac{\sqrt{2} \times V_{ACRMS} - V_{CC(ON)}}{R_{ST}} - I_{CC(OFF)}} \quad (s) \quad (20)$$

In general, power supply applications, C_{VCC} is approximately 22 μF to 47 μF.

• **R_Z, C_{CP} and DZ_{VCC}**

The circuit consists of R_Z, C_{CP} and R_Z is the boost circuit of VCC pin.

R_Z is the limiting resistor for the breakdown current of DZ_{VCC}. The R_Z value is approximately 150 Ω.

C_{CP} is charged when Q1 is in ON state. The C_{CP} value is approximately 22 nF.

Since the absolute maximum rating value of VCC pin is 28 V, the zener voltage of DZ_{VCC} is chosen to be less than it.

• **C7**

If CVCC and the VCC pin are distant from each other, a capacitor C7 should be placed as close as possible to the VCC pin. C7 is approximately 1000 pF, in order to reduce the switching noise.

9.3 PCB Trace Layout and Component Placement

Since the PCB traces design and the component layout significantly affects operation, EMI noise, and power dissipation, the high frequency PCB trace should be low impedance with small loop and wide trace.

In addition, the ground traces affect radiated EMI noise, and wide, short traces should be taken into account.

Figure 9-6 shows the circuit design example.

(1) Main Circuit Trace

This is the main trace containing switching currents, and thus it should be as wide trace and small loop as possible.

(2) Control Ground Trace Layout

Since the operation of IC may be affected from the large current of the main trace that flows in control ground trace, the control ground trace should be separated from main trace and connected at a single point grounding of point A in Figure 9-6 as close to the R_{CS} pin as possible.

(3) R_{CS} Trace Layout

R_{CS} should be placed as close as possible to the Source pin and the CS pin. The peripheral components of CS pin should be connected by dedicated pattern from root of R_{CS} .

The connection between the power ground of the main trace and the IC ground should be at a single point ground (point A in Figure 9-6) which is close to the base of R_{CS} .

(4) Peripheral Component of IC

The components for control connected to the IC should be placed as close as possible to the IC, and should be connected as short as possible to the each pin.

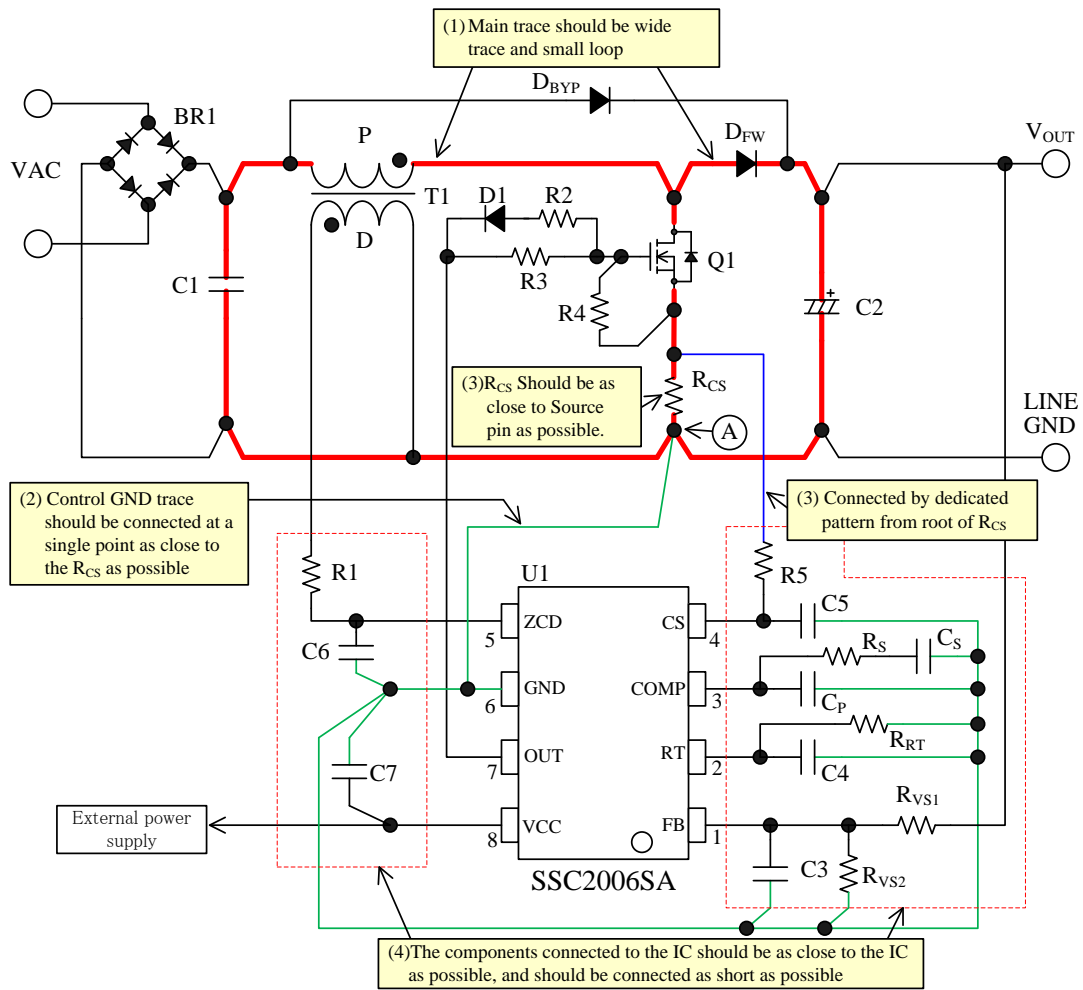

Figure 9-6 Example of connection of peripheral component

10. Reference Design of Power Supply

As an example, the following show the power supply specification, the circuit schematic, the bill of materials, and the transformer specification.

• Circuit schematic

IC	SSC2006SA
Input voltage	AC 85 V to AC 265 V
Output power	130 W (395V, 0.33 A)
Minimum frequency	30 kHz

• Circuit schematic

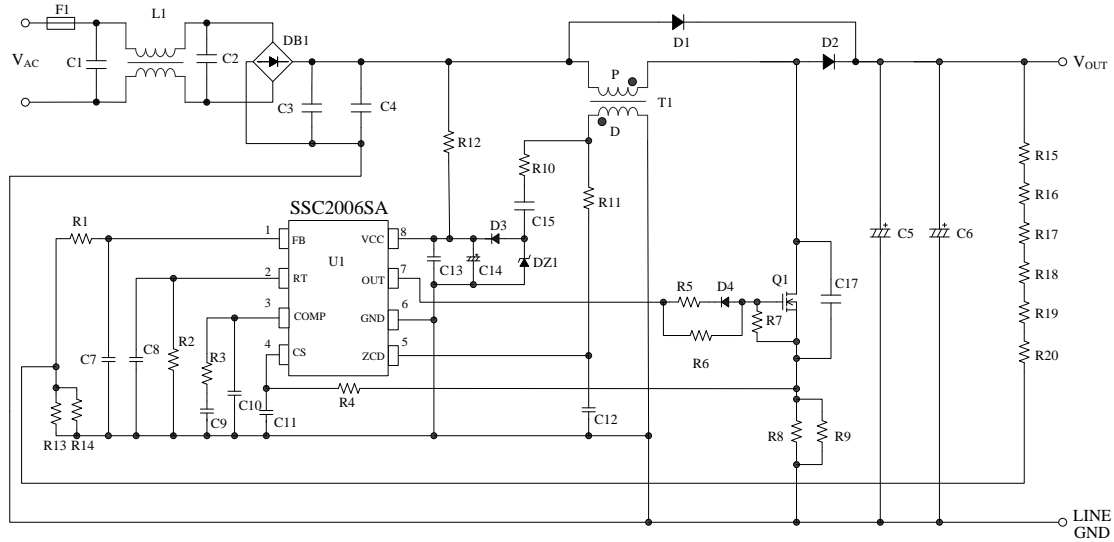

• Bill of materials

Symbol	Ratings ⁽¹⁾	Recommended Sanken Parts	Symbol	Ratings ⁽¹⁾	Recommended Sanken Parts
F1	Fuse, AC250 V, 4 A		R1	1 kΩ	
L1	⁽²⁾ CM inductor, 18 mH		R2	33 kΩ	
DB1	Bridge diode, 600 V, 4 A		R3	22 kΩ	
D1	600 V, 3 A	RM 4A	R4	47 Ω	
D2	Fast recovery, 600 V, 5 A	FMX-G16S	R5	22 Ω	
D3	Fast recovery, 200V, 1A	AL01Z	R6	68 Ω	
D4	Schottky diode, 40 V, 1 A	AK 04	R7	10 kΩ	
C1	⁽²⁾ Film, 0.1 μF, 310 V		R8	0.15 Ω, 1 W	
C2	⁽²⁾ Film, 0.1 μF, 310 V		R9	0.15 Ω, 1 W	
C3	Ceramic, 1 μF, 450V		R10	150 Ω	
C4	⁽²⁾ Ceramic, 1 μF, 450V		R11	33 kΩ	
C5	Electrolytic, 100 μF, 450 V		R12	⁽³⁾ Metal oxide, 2W, 100 kΩ	
C6	⁽²⁾ Electrolytic, Open		R13	± 1 %, 33 kΩ	
C7	Ceramic, 1000 pF		R14	± 1 %, 68 kΩ	
C8	Ceramic, 0.01 μF		R15	± 1 %, 680 kΩ	
C9	Ceramic, 1 μF		R16	± 1 %, 680 kΩ	
C10	Ceramic, 1000 pF		R17	± 1 %, 680 kΩ	
C11	Ceramic, 3300 pF		R18	± 1 %, 680 kΩ	
C12	⁽²⁾ Ceramic, 10 pF		R19	⁽²⁾⁽³⁾ ± 1 %, 560 kΩ	
C13	⁽²⁾ Ceramic, 1000 pF		R20	⁽²⁾⁽³⁾ ± 1 %, 180 kΩ	
C14	Electrolytic, 47 μF, 35V		Q1	Power MOSFET, 600 V, 13A, 0.26 Ω	
C15	Ceramic, 0.022 μF		T1	See the specification	
C16	⁽²⁾ Ceramic, 100 pF, 1 kV		U1	IC	SSC2006SA
DZ1	Zener, V _Z = 20 V				

⁽¹⁾ Unless otherwise specified, the voltage rating of capacitor is 50 V or less and the power rating of resistor is 1/8 W or less.

⁽²⁾ It is necessary to be adjusted based on actual operation in the application.

⁽³⁾ Resistors applied high DC voltage and of high resistance are recommended to select resistors designed against electromigration or use combinations of resistors in series for that to reduce each applied voltage, according to the requirement of the application.

SSC2006SA

- Transformer specification

Primary inductance : 620 μ H
 Core size : SDT38
 AL-Value : 198 nH/N²
 Gap length : 1.9 mm (center gap)

Winding specification

Location	Symbol	Number of turns (turns)	Wire (mm)	Configuration	Note
Primary winding	P1	56	ϕ 0.20 \times 10p	Solenoid winding	Litz wire
Auxiliary winding	D	8	ϕ 0.32	Solenoid winding	

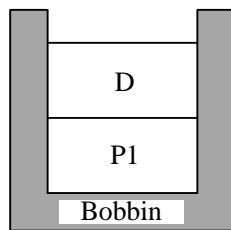

Cross-section view

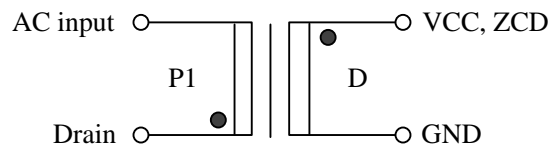

● mark shows the start point of winding

OPERATING PRECAUTIONS

In the case that you use Sanken products or design your products by using Sanken products, the reliability largely depends on the degree of derating to be made to the rated values. Derating may be interpreted as a case that an operation range is set by derating the load from each rated value or surge voltage or noise is considered for derating in order to assure or improve the reliability. In general, derating factors include electric stresses such as electric voltage, electric current, electric power etc., environmental stresses such as ambient temperature, humidity etc. and thermal stress caused due to self-heating of semiconductor products. For these stresses, instantaneous values, maximum values and minimum values must be taken into consideration. In addition, it should be noted that since power devices or IC's including power devices have large self-heating value, the degree of derating of junction temperature affects the reliability significantly.

Because reliability can be affected adversely by improper storage environments and handling methods, please observe the following cautions.

Cautions for Storage

- Ensure that storage conditions comply with the standard temperature (5 to 35°C) and the standard relative humidity (around 40 to 75%); avoid storage locations that experience extreme changes in temperature or humidity.
- Avoid locations where dust or harmful gases are present and avoid direct sunlight.
- Reinspect for rust on leads and solderability of the products that have been stored for a long time.

Cautions for Testing and Handling

When tests are carried out during inspection testing and other standard test periods, protect the products from power surges from the testing device, shorts between the product pins, and wrong connections. Ensure all test parameters are within the ratings specified by Sanken for the products.

Soldering

When soldering the products, please be sure to minimize the working time, within the following limits:

- 260 ± 5 °C 10 ± 1 s (Flow, 2 times)
- 380 ± 10 °C 3.5 ± 0.5 s (Soldering iron, 1 time)

Electrostatic Discharge

- When handling the products, the operator must be grounded. Grounded wrist straps worn should have at least 1MΩ of resistance from the operator to ground to prevent shock hazard, and it should be placed near the operator.
- Workbenches where the products are handled should be grounded and be provided with conductive table and floor mats.
- When using measuring equipment such as a curve tracer, the equipment should be grounded.
- When soldering the products, the head of soldering irons or the solder bath must be grounded in order to prevent leak voltages generated by them from being applied to the products.
- The products should always be stored and transported in Sanken shipping containers or conductive containers, or be wrapped in aluminum foil.

IMPORTANT NOTES

- The contents in this document are subject to changes, for improvement and other purposes, without notice. Make sure that this is the latest revision of the document before use.
- Application examples, operation examples and recommended examples described in this document are quoted for the sole purpose of reference for the use of the products herein and Sanken can assume no responsibility for any infringement of industrial property rights, intellectual property rights, life, body, property or any other rights of Sanken or any third party which may result from its use.
- Unless otherwise agreed in writing by Sanken, Sanken makes no warranties of any kind, whether express or implied, as to the products, including product merchantability, and fitness for a particular purpose and special environment, and the information, including its accuracy, usefulness, and reliability, included in this document.
- Although Sanken undertakes to enhance the quality and reliability of its products, the occurrence of failure and defect of semiconductor products at a certain rate is inevitable. Users of Sanken products are requested to take, at their own risk, preventative measures including safety design of the equipment or systems against any possible injury, death, fires or damages to the society due to device failure or malfunction.
- Sanken products listed in this document are designed and intended for the use as components in general purpose electronic equipment or apparatus (home appliances, office equipment, telecommunication equipment, measuring equipment, etc.).
When considering the use of Sanken products in the applications where higher reliability is required (transportation equipment and its control systems, traffic signal control systems or equipment, fire/crime alarm systems, various safety devices, etc.), and whenever long life expectancy is required even in general purpose electronic equipment or apparatus, please contact your nearest Sanken sales representative to discuss, prior to the use of the products herein.
The use of Sanken products without the written consent of Sanken in the applications where extremely high reliability is required (aerospace equipment, nuclear power control systems, life support systems, etc.) is strictly prohibited.
- When using the products specified herein by either (i) combining other products or materials therewith or (ii) physically, chemically or otherwise processing or treating the products, please duly consider all possible risks that may result from all such uses in advance and proceed therewith at your own responsibility.
- Anti radioactive ray design is not considered for the products listed herein.
- Sanken assumes no responsibility for any troubles, such as dropping products caused during transportation out of Sanken's distribution network.
- The contents in this document must not be transcribed or copied without Sanken's written consent.