



TDA7465

DIGITALLY CONTROLLED AUDIO PROCESSOR WITH SRS SURROUND SOUND AND VOICE CANCELLER



The Device incorporates the SRS WOW® Technology under licence from SRS Labs, Inc.

- 1 STEREO INPUT AND 1 MIXER INPUT
- INPUT ATTENUATION CONTROL IN 0.5dB STEP
- TREBLE MIDDLE AND BASS CONTROL
- VOICE CANCELLER IS AVAILABLE
- STEREO SRS SURROUND SOUND WITH CENTER & SPACE CONTROL IS AVAILABLE
- THREE STANDARD SURROUND MODES ARE AVAILABLE:
 - MUSIC IN 4 DIFFERENT SELECTABLE RESPONSES
 - MOVIE AND SIMULATED IN 256 DIFFERENT SELECTABLE RESPONSES
- REAR OUTPUT IS AVAILABLE TO DRIVE EXTRA SURROUND SPEAKERS
- 2 SPEAKERS OUTPUTS
 - INDEPENDENT ATTENUATORS IN 1dB STEP FOR BALANCE FACILITY
 - ZERO CROSSING ATTENUATION AVAILABLE
 - INDEPENDENT MUTE FUNCTION
- 2 RECORD OUTPUTS
 - INDEPENDENT ATTENUATORS IN 1dB STEP FOR BALANCE FACILITY
 - MUX AVAILABLE FOR PROCESSES SIGNAL SELECTION
 - INDEPENDENT MUTE FUNCTION
- ALL FUNCTIONS PROGRAMMABLE VIA SERIAL BUS
- ADDRESS PIN AVAILABLE

DESCRIPTION

The TDA7465 is a volume tone (bass middle and treble) balance (Left/Right) processors with stereo SRS and voice canceller for quality audio applications in car radio, Hi-Fi, TV systems.

It reproduces SRS (Sound Retrieval System) sound by external components and surround sound by using phase shifters and a signal matrix. The AC signal setting is obtained by resistor networks and switches combined with operational amplifiers according to the SRS laboratories specification. An Extra Mix Input is available to

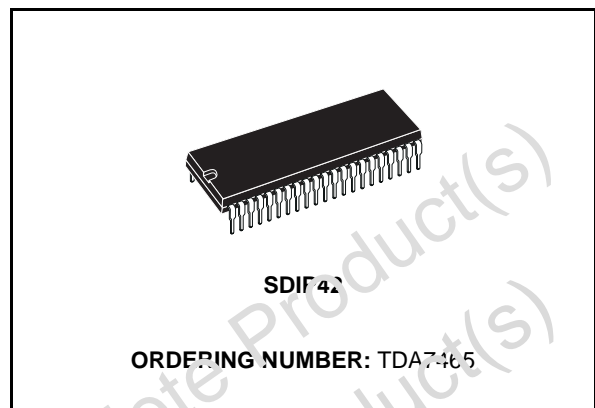

PIN CONNECTION

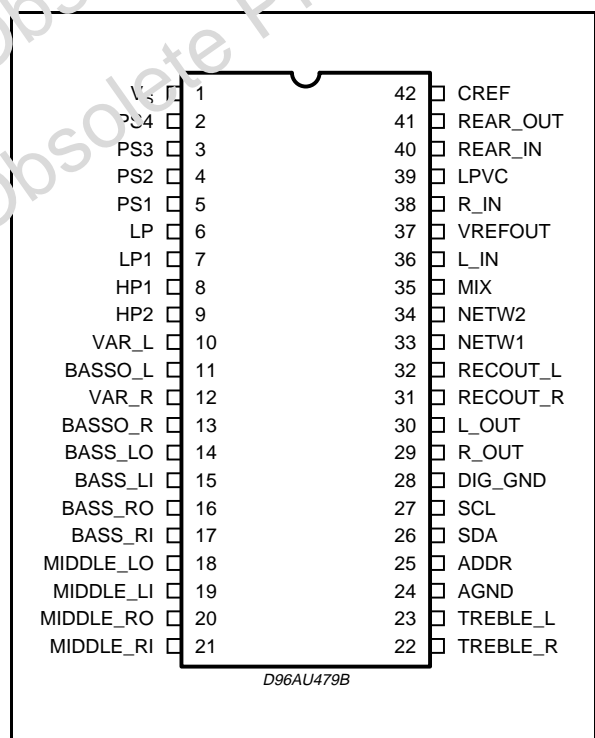

connect microphone for KARAOKE feature. Control of all the functions is accomplished by serial bus.

Thanks to the used BIPOLAR/CMOS Technology, Low Distortion, Low Noise and DC stepping are obtained.

BLOCK DIAGRAM

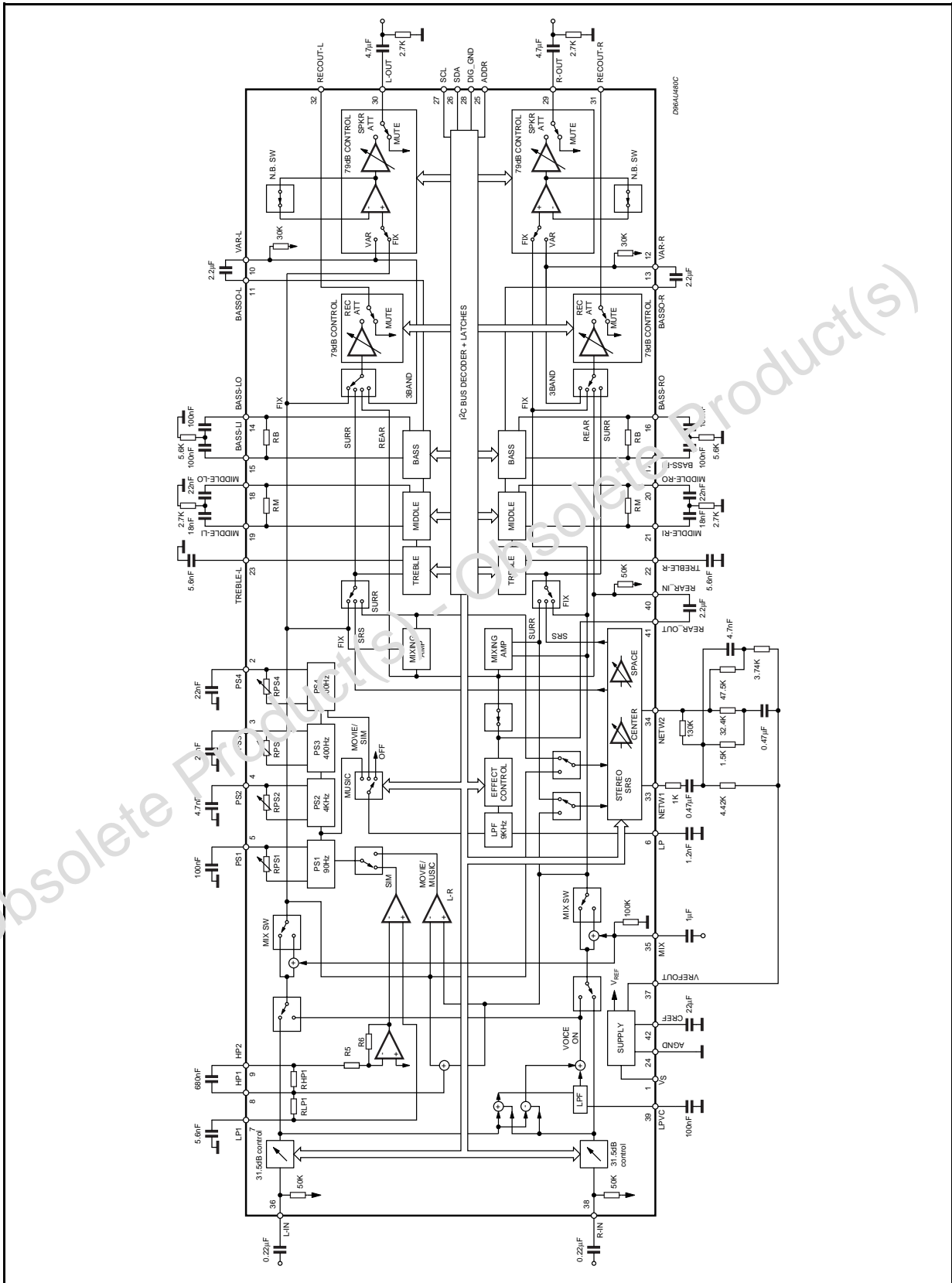

THERMAL DATA

| Symbol | Description | Value | Unit |
|------------------|----------------------------------|---------|------|
| $R_{th\ j-pins}$ | Thermal Resistance Junction-pins | Max. 85 | °C/W |

ABSOLUTE MAXIMUM RATINGS

| Symbol | Parameter | Value | Unit |
|-----------|-------------------------------|-------------|------|
| V_S | Operating Supply Voltage | 11 | V |
| T_{amb} | Operating Ambient Temperature | -10 to 85 | °C |
| T_{stg} | Storage Temperature Range | -55 to +150 | °C |

QUICK REFERENCE DATA

| Symbol | Parameter | Min. | Typ. | Max. | Unit |
|----------|---|-------|------|------|------------------|
| V_S | Supply Voltage | 7 | 9 | 10.2 | V |
| V_{CL} | Max. input signal handling | 2 | | | V _{rms} |
| THD | Total Harmonic Distortion $V = 1V_{rms}$ $f = 1KHz$ | | 0.01 | 0.1 | % |
| S/N | Signal to Noise Ratio $V_{out} = 1V_{rms}$ (mode = OFF) | | 106 | | dB |
| S_C | Channel Separation $f = 1KHz$ | | 90 | | dB |
| | Input Attenuation Control (0.5dB) | -31.5 | | 0 | dB |
| | Treble Control (2db step) | -14 | | +14 | dB |
| | Middle Control (2db step) | -14 | | +14 | dB |
| | Bass Control (2dB step) | -14 | | +14 | dB |
| | Balance Control 1dB step (Lch, Rch) | -79 | | 0 | dB |
| | Mute Attenuation | | 100 | | dB |

ELECTRICAL CHARACTERISTICS (refer to the test circuit $T_{amb} = 25^\circ C$, $V_S = 9V$, $R_L = 10K\Omega$, $V_{in} = 1V_{rms}$; $R_G = 600\Omega$, all controls flat ($G = 0dB$), Effect Ctrl = -6dB, MODE = OFF; $f = 1KHz$ unless otherwise specified)

| Symbol | Parameter | Test Condition | Min. | Typ. | Max. | Unit |
|--------|-----------|----------------|------|------|------|------|
|--------|-----------|----------------|------|------|------|------|

SUPPLY

| | | | | | | |
|-------|------------------|---------------------------|----|----|------|----|
| V_S | Supply Voltage | | 7 | 9 | 10.2 | V |
| I_S | Supply Current | | | 25 | | mA |
| SVR | Ripple Rejection | LCH / RCH out, Mode = OFF | 60 | 80 | | dB |

INPUT STAGE

| | | | | | | |
|-------------|--------------------------|--|------|------|------|------------------|
| R_{IN} | Input Resistance | | 37.5 | 50 | 62.5 | K Ω |
| V_{CL} | Clipping Level | THD = 0.3% | 2 | 2.5 | | V _{rms} |
| A_{RANGE} | Attenuation Range | | | 31.5 | | dB |
| A_{VMIN} | Min. Attenuation | | -1 | 0 | 1 | dB |
| A_{VMAX} | Max. Attenuation | | 31 | 31.5 | 32 | dB |
| A_{STEP} | Step Resolution | | -1 | 0.5 | 1 | dB |
| V_{DC} | DC Steps | Adjacent att. step | -3 | 0 | 3 | mV |
| A_{VO1} | Voice Canceller Output 1 | $L_{IN} = R_{IN}$, $R_{IN} = ON$, $V_{mix} = 0V\ FIX$, 0dB attenuation | 5 | 6 | 7 | dB |
| A_{VO2} | Voice Canceller Output 2 | $L_{IN} = R_{IN} = 0V$ $V_{mix} = 1V_{rms}\ FIX$, 0dB attenuation | -1 | 0 | 1 | dB |

ELECTRICAL CHARACTERISTICS (continued)

| Symbol | Parameter | Test Condition | Min. | Typ. | Max. | Unit |
|-----------------------|------------------------------|---|-------|-------|-------|------|
| SUPPLY | | | | | | |
| A _{VO3} | Voice Canceller Output 3 | L _{IN} = -R _{IN} , V _{mix} = 0V FIX, 0dB attenuation | 5 | 6 | 7 | dB |
| R _{LPV} | Low Pass Filter Resistance | | 24 | 32 | 40 | KΩ |
| R _{MIX} | Input Impedance | | 75 | 100 | 125 | KΩ |
| BASS CONTROL | | | | | | |
| G _b | Control Range | Max. Boost/cut | ±12.0 | ±14.0 | ±16.0 | dB |
| B _{STEP} | Step Resolution | | 1 | 2 | 3 | dB |
| R _B | Internal Feedback Resistance | | 33 | 44 | 55 | KΩ |
| MIDDLE CONTROL | | | | | | |
| G _m | Control Range | Max. Boost/cut | ±12.0 | ±14.0 | ±16.0 | dB |
| M _{STEP} | Step Resolution | | 1 | 2 | 3 | dB |
| R _M | Internal Feedback Resistance | | 18.75 | 25 | 31.25 | KΩ |
| TREBLE CONTROL | | | | | | |
| G _t | Control Range | Max. Boost/cut | ±13.0 | ±14.0 | ±15.0 | dB |
| T _{STEP} | Step Resolution | | 1 | 2 | 3 | dB |

STANDARD SURROUND SOUND MATRIX

TEST CONDITION (Phase Resistor Selection D0=0, L1=1, D2=0, D3=1, D4=0, D5=1, D6=0, D7=1)

| Symbol | Parameter | Test Condition | Min. | Typ. | Max. | Unit |
|------------------------------|-------------------------------------|--|------|------|------|------|
| G _{OFF} | In-phase Gain (OFF) | Mode OFF, Input signal of 1kHz, 1.4 V _{p-p} , R _{in} → R _{out} , L _{in} → L _{out} | -1 | 0 | 1 | dB |
| D _{G_{OFF}} | LR In-phase Gain Difference (OFF) | Mode OFF, Input signal of 1kHz, 1.4 V _{p-p} , R _{in} → R _{out} , L _{in} → L _{out} | -1 | 0 | 1 | dB |
| G _{MOV} | In-phase Gain (Movie) | Movie mode, Effect Ctrl = -6dB Input signal of 1kHz, 1.4 V _{p-p} , R _{in} → R _{out} , L _{in} → L _{out} | | 8 | | dB |
| D _{G_{MOV}} | LR In-phase Gain Difference (Movie) | Movie mode, Effect Ctrl = -6dB Input signal of 1kHz, 1.4 V _{p-p} , (R _{in} → R _{out}) - (L _{in} → L _{out}) | | 0 | | dB |
| G _{MUS} | In-phase Gain (Music) | Music mode, Effect Ctrl = -6dB Input signal of 1kHz, 1.4 V _{p-p} , (R _{in} → R _{out}), (L _{in} → L _{out}) | | 7 | | dB |
| D _{G_{MUS}} | LR In-phase Gain Difference (Music) | Music mode, Effect Ctrl = -6dB Input signal of 1kHz, 1.4 V _{p-p} , (R _{in} → R _{out}) - (L _{in} → L _{out}) | | 0 | | dB |
| L _{MON1} | Simulated L Output 1 | Simulated Mode, Effect Ctrl = -6dB Input signal of 250Hz, 1.4 V _{p-p} , R _{in} and L _{in} → L _{out} | | 4.5 | | dB |
| L _{MON2} | Simulated L Output 2 | Simulated Mode, Effect Ctrl = -6dB Input signal of 1kHz, 1.4 V _{p-p} , R _{in} and L _{in} → L _{out} | | -4.0 | | dB |
| L _{MON3} | Simulated L Output 3 | Simulated Mode, Effect Ctrl = -6dB Input signal of 3.6kHz, 1.4 V _{p-p} , R _{in} and L _{in} → L _{out} | | 7.0 | | dB |

ELECTRICAL CHARACTERISTICS (continued)

| Symbol | Parameter | Test Condition | Min. | Typ. | Max. | Unit |
|----------------------|-----------------------------|--|------|-------|------|------|
| R _{MON1} | Simulated R Output 1 | Simulated Mode, Effect Ctrl = -6dB Input signal of 250Hz, 1.4 V _{p-p} , R _{in} and L _{in} → R _{out} | | - 4.5 | | dB |
| R _{MON2} | Simulated R Output 2 | Simulated Mode, Effect Ctrl = -6dB Input signal of 1kHz, 1.4 V _{p-p} , R _{in} and L _{in} → R _{out} | | 3.8 | | dB |
| R _{MON3} | Simulated R Output 3 | Simulated Mode, Effect Ctrl = -6dB Input signal of 3.6kHz, 1.4 V _{p-p} , R _{in} and L _{in} → R _{out} | | - 20 | | dB |
| R _{LP1} | Low Pass Filter Resistance | | 7.5 | 10 | 12.5 | KΩ |
| R _{HPI} | High Pass Filter Resistance | | 45 | 60 | 75 | KΩ |
| R _{LPF} | LP Pin Impedance | | 7.5 | 10 | 12.5 | KΩ |
| R _{REARIN} | Rear Input Resistance | D6 = 0 | 37.5 | 50 | 62.5 | KΩ |
| R _{REAROUT} | Rear Output Resistance | D6 = 0 | 10 | 30 | 50 | Ω |
| V _{OUT} | DC Rear Voltage Level | D6 = 0 | | 4.5 | | V |

STANDARD SURROUND SOUND EFFECT CONTROL

| | | | | | | |
|--------------------|-----------------|--|----|---|-----|----|
| C _{RANGE} | Control Range | | 21 | | - 6 | dB |
| S _{STEP} | Step Resolution | | | 1 | | dB |

SURROUND SOUND MATRIX PHASE

| | | | | | | |
|-------------------|---------------------------------|--|------|------|------|----|
| R _{PS10} | Phase Shifter 1: D1 = 0, D0 = 0 | | 8.8 | 11.8 | 14.8 | KΩ |
| R _{PS11} | Phase Shifter 1: D1 = 0, D0 = 1 | | 10.6 | 14.1 | 17.6 | KΩ |
| R _{PS12} | Phase Shifter 1: D1 = 1, D0 = 0 | | 13.4 | 17.9 | 22.4 | KΩ |
| R _{PS13} | Phase Shifter 1: D1 = 1, D0 = 1 | | 28 | 37.3 | 46.6 | KΩ |
| R _{PS20} | Phase Shifter 2: D3 = 0, D2 = 0 | | 4.2 | 5.6 | 7 | KΩ |
| R _{PS21} | Phase Shifter 2: D3 = 0, D2 = 1 | | 5.1 | 6.8 | 8.5 | KΩ |
| R _{PS22} | Phase Shifter 2: D3 = 1, D2 = 0 | | 6.3 | 8.4 | 10.5 | KΩ |
| R _{PS23} | Phase Shifter 2: D3 = 1, D2 = 1 | | 13.7 | 18.3 | 22.9 | KΩ |
| R _{PS30} | Phase Shifter 3: D5 = 0, D4 = 0 | | 9 | 12.1 | 15.1 | KΩ |
| R _{PS31} | Phase Shifter 3: D5 = 0, D4 = 1 | | 10.9 | 14.5 | 18.1 | KΩ |
| R _{PS32} | Phase Shifter 3: D5 = 1, D4 = 0 | | 13.6 | 18.1 | 22.6 | KΩ |
| R _{PS33} | Phase Shifter 3: D5 = 1, D4 = 1 | | 29.3 | 39.1 | 48.9 | KΩ |
| R _{PS40} | Phase Shifter 4: D7 = 0, D6 = 0 | | 9 | 12.1 | 15.1 | KΩ |

SRS SURROUND SOUND MATRIX

| | | | | | | |
|--------------------|-------------------------|--|-----|------|---|----|
| CENTER | SRS Control Range | | -31 | | 0 | dB |
| Step _C | Center Step Resolution | | | 1 | | dB |
| SPACE | SRS Space Control Range | | | -31 | 0 | dB |
| Step _S | Space Step Resolution | | | 1 | | dB |
| P _{ERSP1} | Perspective 1 | Input Signal of 125Hz SPACE = 0dB, CENTER = MUTE R _{in} = GND; L _{in} → R _{OUT} | | 12 | | dB |
| P _{ERSP2} | Perspective 2 | Input Signal of 2.15KHz SPACE = 0dB, CENTER = MUTE R _{in} = GND; L _{in} → R _{OUT} | | 0 | | dB |
| L+R | L+ R SRS Curve | SPACE = MUTE, CENTER = 0dB R _{in} = GND; L _{in} → R _{OUT} | | -8.5 | | dB |

ELECTRICAL CHARACTERISTICS (continued)

| Symbol | Parameter | Test Condition | Min. | Typ. | Max. | Unit |
|---|--|---|------|----------------------|------|----------------|
| SPEAKER & RECORD ATTENUATORS | | | | | | |
| C _{range} | Control Range | | | 79 | | dB |
| S _{STEP} | Step Resolution | | 0.5 | 1 | 1.5 | dB |
| E _A | Attenuation set error | Av = 0 to -20dB | -1.5 | 0 | 1.5 | dB |
| | | Av = -20 to -79dB | -3 | 0 | 2 | dB |
| V _{DC} | DC Steps | Adjacent att. steps | -3 | 0 | 3 | mV |
| A _{MUTE} | Output Mute Condition | | 70 | 100 | | dB |
| R _{VAR} | Input Impedance | | 22.5 | 30 | 37.5 | KΩ |
| SPEAKER ATTENUATORS | | | | | | |
| V _{TH} | Zero Crossing Threshold | D7 = 0 | | $\frac{V_S}{2} + 20$ | | mV |
| AUDIO OUTPUTS | | | | | | |
| N _{O(OFF)} | Output Noise (OFF) | Output Mute, Flat B _W = 20Hz to 20KHz | | 4 5 | | μVrms μVrms |
| N _{O(MOV)} | Output Noise (Movie) Standard Surround Sound | Mode = Movie, B _W = 20Hz to 20KHz | | 30 | | μVrms |
| N _{O(MUS)} | Output Noise (Music) Standard Surround Sound | Mode = Music, B _W = 20Hz to 20KHz | | 30 | | μVrms |
| N _{O(SIM)} | Output Noise (Simulated) Standard Surround Sound | Mode = Simulated, B _W = 20Hz to 20KHz | | 30 | | μVrms |
| N _{O(SRS)} | Output Noise (SRS) Surround Sound | B _W = 20Hz to 20KHz | | 50 | | μVrms |
| d | Distorsion | A _v = 0 ; V _{in} = 1Vrms | | 0.01 | 0.1 | % |
| S _C | Channel Separation | | 70 | 90 | | dB |
| V _{OCL} | Clipping Level | d = 0.3% | 2 | 2.5 | | Vrms |
| R _{OUT} | Output Resistance | | 10 | 30 | 50 | Ω |
| V _{OUT} | DC Voltage Level | | | 3.8 | | V |
| BUS INPUTS | | | | | | |
| V _{IL} | Input Low Voltage | | | | 1 | V |
| V _{IH} | Input High Voltage | | 3 | | | V |
| I _{IN} | Input Current | | -5 | | +5 | μA |
| V _O | Output Voltage SDA Acknowledge | I _o = 1.6mA | | | 0.4 | V |

I²C BUS INTERFACE

Data transmission from microprocessor to the TDA7465 and viceversa takes place through the 2 wires I²C BUS interface, consisting of the two lines SDA and SCL (pull-up resistors to positive supply voltage must be connected).

Data Validity

As shown in fig. 3, the data on the SDA line must be stable during the high period of the clock. The HIGH and LOW state of the data line can only change when the clock signal on the SCL line is LOW.

Start and Stop Conditions

As shown in fig.4 a start condition is a HIGH to LOW transition of the SDA line while SCL is HIGH. The stop condition is a LOW to HIGH transition of the SDA line while SCL is HIGH.

Byte Format

Every byte transferred on the SDA line must contain 8 bits. Each byte must be followed by an ac-

knowledge bit. The MSB is transferred first.

Acknowledge

The master (μP) puts a resistive HIGH level on the SDA line during the acknowledge clock pulse (see fig. 5). The peripheral (audioprocessor) that acknowledges has to pull-down (LOW) the SDA line during this clock pulse.

The audioprocessor which has been addressed has to generate an acknowledge after the reception of each byte, otherwise the SDA line remains at the HIGH level during the ninth clock pulse time. In this case the master transmitter can generate the STOP information in order to abort the transfer.

Transmission without Acknowledge

Avoiding to detect the acknowledge of the audioprocessor, the μP can use a simpler transmission: simply it waits one clock without checking the slave acknowledging, and sends the new data.

This approach of course is less protected from misworking.

Figure 3: Data Validity on the I²CBUS

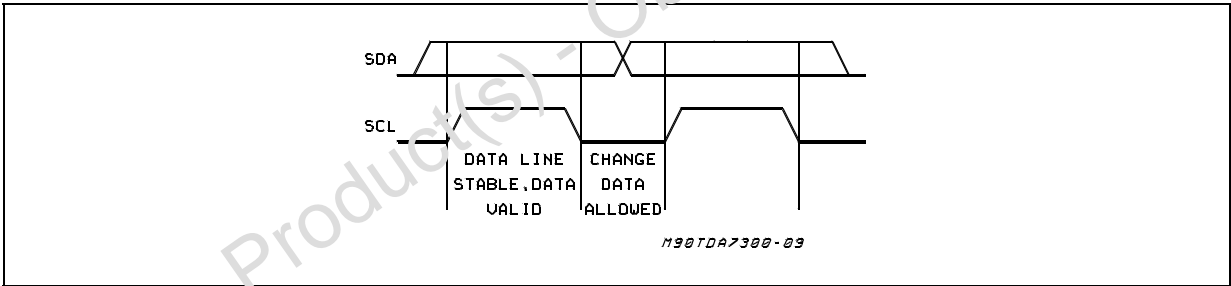

Figure 4: Timing Diagram of I²CBUS

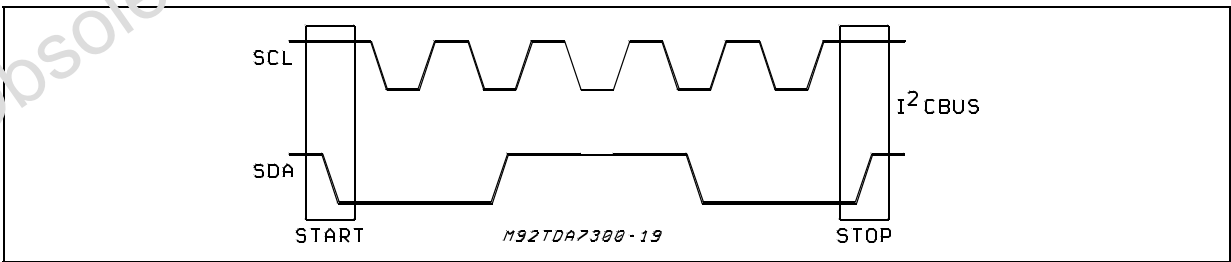
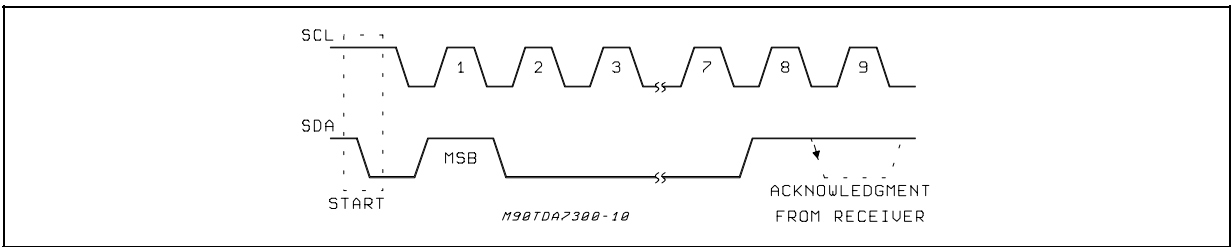

Figure 5: Acknowledge on the I²CBUS



TDA7465

SOFTWARE SPECIFICATION

Interface Protocol

The interface protocol comprises:

- A start condition (S)
- A chip address byte, containing the TDA7465

address

- A subaddress bytes
- A sequence of data (N byte + acknowledge)
- A stop condition (P)

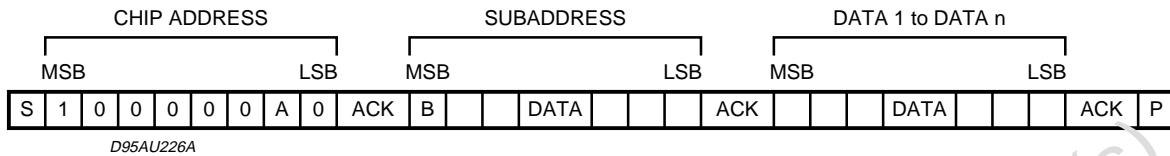

ACK = Acknowledge
 S = Start
 P = Stop
 A = Address
 B = Auto Increment

EXAMPLES

No Incremental Bus

The TDA7465 receives a start condition, the cor-

rect chip address, a subaddress with the MSB = 0 (no incremental bus), N-data (all these data concern the subaddress selected), a stop condition.

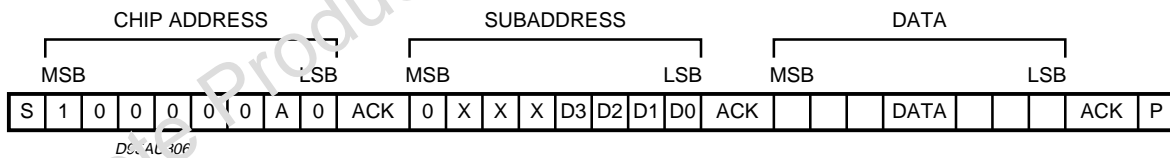

Incremental Bus

The TDA7465 receives a start condition, the correct chip address, a subaddress with the MSB = 1 (incremental bus): now it is in a loop condition with an autoincrease of the subaddress whereas

SUBADDRESS from "1XXX1010" to "1XXX1111" of DATA are ignored. The DATA 1 concerns the subaddress sent, and the DATA 2 concerns the subaddress sent plus one in the loop etc. and, at the end, it receives the stop condition.

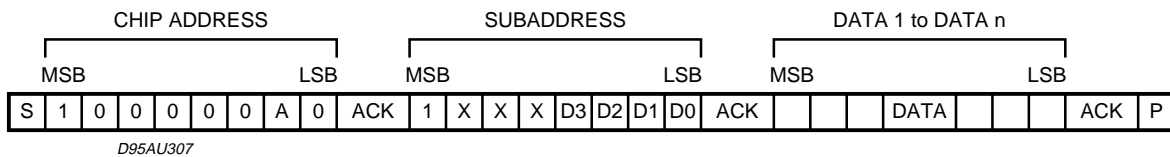

DATA BYTES (Address = 80(HEX) [82(HEX) if ADDRESS pin is connected to Vs]

FUNCTION SELECTION:

The first byte (subaddress)

| MSB | | | | | | | LSB | | SUBADDRESS |
|-----|----|----|----|----|----|----|-----|---------------------------------|------------|
| D7 | D6 | D5 | D4 | D3 | D2 | D1 | D0 | | |
| B | X | X | X | 0 | 0 | 0 | 0 | INPUT ATTENUATION | |
| B | X | X | X | 0 | 0 | 0 | 1 | SURROUND & OUT & EFFECT CONTROL | |
| B | X | X | X | 0 | 0 | 1 | 0 | PHASE RESISTOR | |
| B | X | X | X | 0 | 0 | 1 | 1 | BASS | |
| B | X | X | X | 0 | 1 | 0 | 0 | MIDDLE & TREBLE | |
| B | X | X | X | 0 | 1 | 0 | 1 | SPEAKER ATTENUATION "L" | |
| B | X | X | X | 0 | 1 | 1 | 0 | SPEAKER ATTENUATION "R" | |
| B | X | X | X | 0 | 1 | 1 | 1 | RECORD ATTENUATION "L" | |
| B | X | X | X | 1 | 0 | 0 | 0 | RECORD ATTENUATION "R" | |
| B | X | X | X | 1 | 0 | 0 | 1 | VOICE CANCELLER & REC OUT | |
| B | X | X | X | 1 | 0 | 1 | 0 | SRS / SPACE ATTENUATION | |
| B | X | X | X | 1 | 0 | 1 | 1 | SRS / CENTER ATTENUATION | |

B = 1 INCREMENTAL BUS; ACTIVE

B = 0 NO INCREMENTAL BUS;

X = DONT' CARE

INPUT ATTENUATION SELECTION

| MSB | | | | | | | LSB | | INPUT ATTENUATION |
|-------------------|----|----|----|----|----|----|-----|--------------|-------------------|
| D7 | D6 | D5 | D4 | D3 | D2 | D1 | D0 | 0.5 dB STEPS | |
| | 0 | | | | 0 | 0 | 0 | 0 | |
| | 0 | | | | 0 | 0 | 1 | -0.5 | |
| | 0 | | | | 0 | 1 | 0 | -1 | |
| | 0 | | | | 0 | 1 | 1 | -1.5 | |
| | 0 | | | | 1 | 0 | 0 | -2 | |
| | 0 | | | | 1 | 0 | 1 | -2.5 | |
| | 0 | | | | 1 | 1 | 0 | -3 | |
| | 0 | | | | 1 | 1 | 1 | -3.5 | |
| 4 dB STEPS | | | | | | | | | |
| | 0 | 0 | 0 | 0 | | | | 0 | |
| | 0 | 0 | 0 | 1 | | | | -4 | |
| | 0 | 0 | 1 | 0 | | | | -8 | |
| | 0 | 0 | 1 | 1 | | | | -12 | |
| | 0 | 1 | 0 | 0 | | | | -16 | |
| | 0 | 1 | 0 | 1 | | | | -20 | |
| | 0 | 1 | 1 | 0 | | | | -24 | |
| | 0 | 1 | 1 | 1 | | | | -28 | |

INPUT ATTENUATION = 0 ~ -31.5dB

STANDARD SURROUND SELECTION

| MSB | | | | | | | LSB | | |
|-----|----|----|----|----|----|----|-----|-----------------------|--|
| D7 | D6 | D5 | D4 | D3 | D2 | D1 | D0 | SURROUND MODE | |
| | | | | | | 0 | 0 | SIMULATED | |
| | | | | | | 0 | 1 | MUSIC | |
| | | | | | | 1 | 0 | OFF | |
| | | | | | | 1 | 1 | MOVIE | |
| | | | | | | | | OUT | |
| | | | | | | | | VAR | |
| | | | | | | | | FIX | |
| | | | | | | | | EFFECT CONTROL | |
| | 0 | 0 | 0 | 0 | | | | -6 | |
| | 0 | 0 | 0 | 1 | | | | -7 | |
| | 0 | 0 | 1 | 0 | | | | -8 | |
| | 0 | 0 | 1 | 1 | | | | -9 | |
| | 0 | 1 | 0 | 0 | | | | -10 | |
| | 0 | 1 | 0 | 1 | | | | -11 | |
| | 0 | 1 | 1 | 0 | | | | -12 | |
| | 0 | 1 | 1 | 1 | | | | -13 | |
| | 1 | 0 | 0 | 0 | | | | -14 | |
| | 1 | 0 | 0 | 1 | | | | -15 | |
| | 1 | 0 | 1 | 0 | | | | -16 | |
| | 1 | 0 | 1 | 1 | | | | -17 | |
| | 1 | 1 | 0 | 0 | | | | -18 | |
| | 1 | 1 | 0 | 1 | | | | -19 | |
| | 1 | 1 | 1 | 0 | | | | -20 | |
| | 1 | 1 | 1 | 1 | | | | -21 | |

PHASE RESISTOR SELECTION

| MSB | | | | | | | LSB | | SURROUND PHASE RESISTOR |
|-----|----|----|----|----|----|----|-----|---------------------------|-------------------------|
| D7 | D6 | D5 | D4 | D3 | D2 | D1 | D0 | PHASE SHIFT 1 (KΩ) | |
| | | | | | | 0 | 0 | 12 | |
| | | | | | | 0 | 1 | 14 | |
| | | | | | | 1 | 0 | 18 | |
| | | | | | | 1 | 1 | 39 | |
| | | | | | | | | PHASE SHIFT 2 (KΩ) | |
| | | | | | | | | 6 | |
| | | | | | | | | 7 | |
| | | | | | | | | 8 | |
| | | | | | | | | 18 | |
| | | | | | | | | PHASE SHIFT 3 (KΩ) | |
| | | | | | | | | 12 | |
| | | | | | | | | 14 | |
| | | | | | | | | 18 | |
| | | | | | | | | 39 | |
| | | | | | | | | PHASE SHIFT 4 (KΩ) | |
| 0 | 0 | | | | | | | 12 | |
| 0 | 1 | | | | | | | 14 | |
| 1 | 0 | | | | | | | 18 | |
| 1 | 1 | | | | | | | 39 | |

| BASS SELECTION | | | | | | | | |
|----------------|----|----|----|----|----|----|-----|------------|
| MSB | | | | | | | LSB | BASS |
| D7 | D6 | D5 | D4 | D3 | D2 | D1 | D0 | 2 dB STEPS |
| | | | 1 | 0 | 0 | 0 | 0 | -14 |
| | | | 1 | 0 | 0 | 0 | 1 | -12 |
| | | | 1 | 0 | 0 | 1 | 0 | -10 |
| | | | 1 | 0 | 0 | 1 | 1 | -8 |
| | | | 1 | 0 | 1 | 0 | 0 | -6 |
| | | | 1 | 0 | 1 | 0 | 1 | -4 |
| | | | 1 | 0 | 1 | 1 | 0 | -2 |
| | | | 1 | 0 | 1 | 1 | 1 | 0 |
| | | | 1 | 1 | 1 | 1 | 1 | 0 |
| | | | 1 | 1 | 1 | 1 | 0 | 2 |
| | | | 1 | 1 | 1 | 0 | 1 | 4 |
| | | | 1 | 1 | 1 | 0 | 0 | 6 |
| | | | 1 | 1 | 0 | 1 | 1 | 8 |
| | | | 1 | 1 | 0 | 1 | 0 | 10 |
| | | | 1 | 1 | 0 | 0 | 1 | 12 |
| | | | 1 | 1 | 0 | 0 | 0 | 14 |

| MIDDLE & TREBLE SELECTION | | | | | | | | | |
|---------------------------|----|----|----|----|----|----|-----|-------------------|--|
| MSB | | | | | | | LSB | MIDDLE | |
| D7 | D6 | D5 | D4 | D3 | D2 | D1 | D0 | 2 dB STEPS | |
| | | | | 0 | 0 | 0 | 0 | -14 | |
| | | | | 0 | 0 | 0 | 1 | -12 | |
| | | | | 0 | 0 | 1 | 0 | -10 | |
| | | | | 0 | 0 | 1 | 1 | -8 | |
| | | | | 0 | 1 | 0 | 0 | -6 | |
| | | | | 0 | 1 | 0 | 1 | -4 | |
| | | | | 0 | 1 | 1 | 0 | -2 | |
| | | | | 0 | 1 | 1 | 1 | 0 | |
| | | | | 1 | 1 | 1 | 1 | 0 | |
| | | | | 1 | 1 | 1 | 0 | 2 | |
| | | | | 1 | 1 | 0 | 1 | 4 | |
| | | | | 1 | 1 | 0 | 0 | 6 | |
| | | | | 1 | 0 | 1 | 1 | 8 | |
| | | | | 1 | 0 | 1 | 0 | 10 | |
| | | | | 1 | 0 | 0 | 1 | 12 | |
| | | | | 1 | 0 | 0 | 0 | 14 | |
| | | | | | | | | TREBLE | |
| | | | | | | | | 2 dB STEPS | |
| 0 | 0 | 0 | 0 | | | | | -14 | |
| 0 | 0 | 0 | 1 | | | | | -12 | |
| 0 | 0 | 1 | 0 | | | | | -10 | |
| 0 | 0 | 1 | 1 | | | | | -8 | |
| 0 | 1 | 0 | 0 | | | | | -6 | |
| 0 | 1 | 0 | 1 | | | | | -4 | |
| 0 | 1 | 1 | 0 | | | | | -2 | |
| 0 | 1 | 1 | 1 | | | | | 0 | |
| 1 | 1 | 1 | 1 | | | | | 0 | |
| 1 | 1 | 1 | 0 | | | | | 2 | |
| 1 | | 0 | 1 | | | | | 4 | |
| 1 | 1 | 0 | 0 | | | | | 6 | |
| 1 | 0 | 1 | 1 | | | | | 8 | |
| 1 | 0 | 1 | 0 | | | | | 10 | |
| 1 | 0 | 0 | 1 | | | | | 12 | |
| 1 | 0 | 0 | 0 | | | | | 14 | |

| LEFT CHANNEL SPEAKER ATTENUATION SELECTION | | | | | | | | |
|--|----|----|----|----|----|----|-----|----------------------|
| MSB | | | | | | | LSB | SPEAKER/RECORD ATT |
| D7 | D6 | D5 | D4 | D3 | D2 | D1 | D0 | 1 dB STEPS |
| | | | | | 0 | 0 | 0 | 0 |
| | | | | | 0 | 0 | 1 | -1 |
| | | | | | 0 | 1 | 0 | -2 |
| | | | | | 0 | 1 | 1 | -3 |
| | | | | | 1 | 0 | 0 | -4 |
| | | | | | 1 | 0 | 1 | -5 |
| | | | | | 1 | 1 | 0 | -6 |
| | | | | | 1 | 1 | 1 | -7 |
| | | | | | | | | 8 dB STEPS |
| | 0 | 0 | 0 | 0 | | | | 0 |
| | 0 | 0 | 0 | 1 | | | | -8 |
| | 0 | 0 | 1 | 0 | | | | -16 |
| | 0 | 0 | 1 | 1 | | | | -24 |
| | 0 | 1 | 0 | 0 | | | | -32 |
| | 0 | 1 | 0 | 1 | | | | -40 |
| | 0 | 1 | 1 | 0 | | | | -48 |
| | 0 | 1 | 1 | 1 | | | | -56 |
| | 1 | 0 | 0 | 0 | | | | -64 |
| | 1 | 0 | 0 | 1 | | | | -72 |
| | | | | | | | | MUTE |
| | 1 | 0 | 1 | X | | | | |
| | 1 | 1 | X | X | | | | |
| LEFT & RIGHT CHANNELS BOTH | | | | | | | | |
| MSB | | | | | | | LSB | ZERO CROSS ATT. MODE |
| D7 | D6 | D5 | D4 | D3 | D2 | D1 | D0 | 1 dB STEPS |
| 0 | | | | | | | | ON |
| 1 | | | | | | | | OFF |

X = DON' TCARE
 SPEAKER/RECORD ATTENUATION = 0dB ~ -79dB

| RECORD AND RIGHT CHANNEL SPEAKER ATTENUATION SELECTION | | | | | | | | |
|--|----|----|----|----|----|----|-----|--------------------|
| MSB | | | | | | | LSB | SPEAKER/RECORD ATT |
| D7 | D6 | D5 | D4 | D3 | D2 | D1 | D0 | 1 dB STEPS |
| | | | | | 0 | 0 | 0 | 0 |
| | | | | | 0 | 0 | 1 | -1 |
| | | | | | 0 | 1 | 0 | -2 |
| | | | | | 0 | 1 | 1 | -3 |
| | | | | | 1 | 0 | 0 | -4 |
| | | | | | 1 | 0 | 1 | -5 |
| | | | | | 1 | 1 | 0 | -6 |
| | | | | | 1 | 1 | 1 | -7 |
| | | | | | | | | 8 dB STEPS |
| | 0 | 0 | 0 | 0 | | | | 0 |
| | 0 | 0 | 0 | 1 | | | | -8 |
| | 0 | 0 | 1 | 0 | | | | -16 |
| | 0 | 0 | 1 | 1 | | | | -24 |
| | 0 | 1 | 0 | 0 | | | | -32 |
| | 0 | 1 | 0 | 1 | | | | -40 |
| | 0 | 1 | 1 | 0 | | | | -48 |
| | 0 | 1 | 1 | 1 | | | | -56 |
| | 1 | 0 | 0 | 0 | | | | -64 |
| | 1 | 0 | 0 | 1 | | | | -72 |
| | | | | | | | | MUTE |
| | 1 | 0 | 1 | X | | | | |
| | 1 | 1 | X | X | | | | |

X = DON'T CARE
 SPEAKER/RECORD ATTENUATION = 0dB ~ -79dB

| VOICE CANCELLER REC OUT L & R SELECTION | | | | | | | | |
|---|----|----|----|----|----|----|-----|--------------------|
| MSB | | | | | | | LSB | |
| D7 | D6 | D5 | D4 | D3 | D2 | D1 | D0 | VOICE CANCELLER |
| | | | | | 1 | 1 | 0 | OFF |
| | | | | | 1 | 1 | 1 | ON |
| | | | | | | | | REC OUT "L" |
| | | | 0 | 0 | 1 | 1 | | VAR 1 (3BAND) |
| | | | 0 | 1 | 1 | 1 | | VAR 2 (SURR) |
| | | | 1 | 0 | 1 | 1 | | VAR 3 (REAR) |
| | | | 1 | 1 | 1 | 1 | | FIX |
| | | | | | | | | REC OUT "R" |
| | 0 | 0 | | | 1 | 1 | | VAR 1(3BAND) |
| | 0 | 1 | | | 1 | 1 | | VAR 2 (SURR) |
| | 1 | 0 | | | 1 | 1 | | VAR 3 (REAR) |
| | 1 | 1 | | | 1 | 1 | | FIX |
| | | | | | | | | MIX SWITCH |
| 0 | | | | | 1 | 1 | | MIX PIN ACTIVE |
| 1 | | | | | 1 | 1 | | NO MIX PIN |

| SRS SPACE CONTROL: ATTENUATION SELECTION | | | | | | | | | |
|--|----|----|----|----|----|----|-----|-------------------|--|
| MSB | | | | | | | LSB | SPACE ATTENUATION | |
| D7 | D6 | D5 | D4 | D3 | D2 | D1 | D0 | 1 dB STEPS | |
| | | | | | 0 | 0 | 0 | 0 | |
| | | | | | 0 | 0 | 1 | -1 | |
| | | | | | 0 | 1 | 0 | -2 | |
| | | | | | 0 | 1 | 1 | -3 | |
| | | | | | 1 | 0 | 0 | -4 | |
| | | | | | 1 | 0 | 1 | -5 | |
| | | | | | 1 | 1 | 0 | -6 | |
| | | | | | 1 | 1 | 1 | -7 | |
| | | | | | | | | 8 dB STEPS | |
| | | 0 | 0 | 0 | | | | 0 | |
| | | 0 | 0 | 1 | | | | -8 | |
| | | 0 | 1 | 0 | | | | -16 | |
| | | 0 | 1 | 1 | | | | -24 | |
| | | | | | | | | MUTE | |
| | | 1 | X | X | X | X | X | | |

X = DON'T CARE

SPEAKER/RECORD ATTENUATION = 0dB ~ -31dB

| SRS CENTER CONTROL: ATTENUATION SELECTION | | | | | | | | | |
|---|----|----|----|----|----|----|-----|--------------------|--|
| MSB | | | | | | | LSB | CENTER ATTENUATION | |
| D7 | D6 | D5 | D4 | D3 | D2 | D1 | D0 | 1 dB STEPS | |
| | | | | | 0 | 0 | 0 | 0 | |
| | | | | | 0 | 0 | 1 | -1 | |
| | | | | | 0 | 1 | 0 | -2 | |
| | | | | | 0 | 1 | 1 | -3 | |
| | | | | | 1 | 0 | 0 | -4 | |
| | | | | | 1 | 0 | 1 | -5 | |
| | | | | | 1 | 1 | 0 | -6 | |
| | | | | | 1 | 1 | 1 | -7 | |
| | | | | | | | | 8 dB STEPS | |
| | | 0 | 0 | 0 | | | | 0 | |
| | | 0 | 0 | 1 | | | | -8 | |
| | | 0 | 1 | 0 | | | | -16 | |
| | | 0 | 1 | 1 | | | | -24 | |
| | | | | | | | | MUTE | |
| | | 1 | X | X | X | X | X | | |
| | | | | | | | | SRS INPUT | |
| | 0 | | | | | | | NO SURROUND SIGNAL | |
| | 1 | | | | | | | SURROUND SIGNAL | |
| | | | | | | | | SRS SWITCH | |
| | 0 | | | | | | | SRS ON | |
| | 1 | | | | | | | SRS OFF | |

X = DONT' CARE

SPACE ATTENUATION = 0dB ~ -31dB

RECOMMENDED TO ATTENUATE -3dB IN INPUT ATTENUATION DURING "SRS OFF"
TO FULFILL SRS BYPASS MODE WHEN SRS FUNCTION IS USED

| POWER ON RESET | |
|--|-----------------------------|
| SURROUND & OUT CONTROL+ EFFECT CONTROL | OFF + FIX + MAX ATTENUATION |
| SPEAKER/RECORD ATTENUATION L & R MODE | MUTE + ZERO CROSS ATT.OFF |
| INPUT ATTENUATION + REAR SWITCH | MAX ATTENUATION + ON |
| VOICE CANCELLER | OFF |
| INPUT | IN1 |
| MIX SWITCH | NO MIX PIN |
| SRS SURROUND | OFF + MAX ATTENUATION |
| BASS & MIDDLE | 2dB |
| TREBLE | 0dB |

PIN DESCRIPTION

PIN: REAR OUT

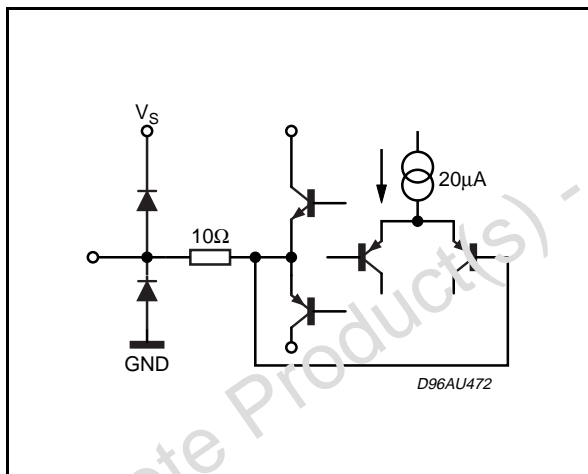

PIN: HP1

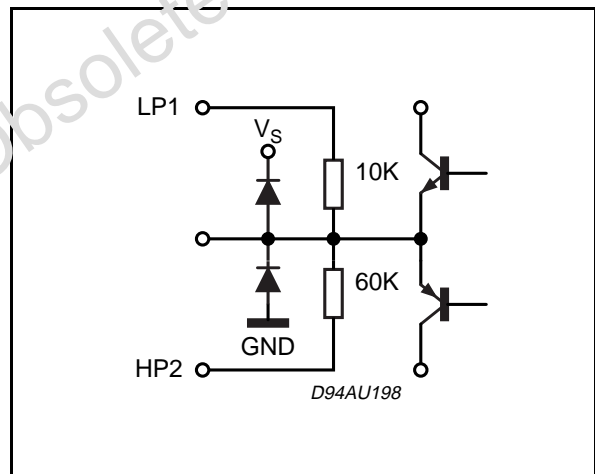

PIN: HP2

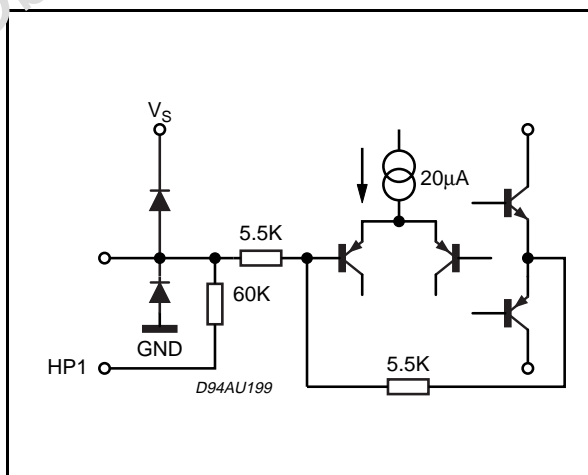

PIN: MIX

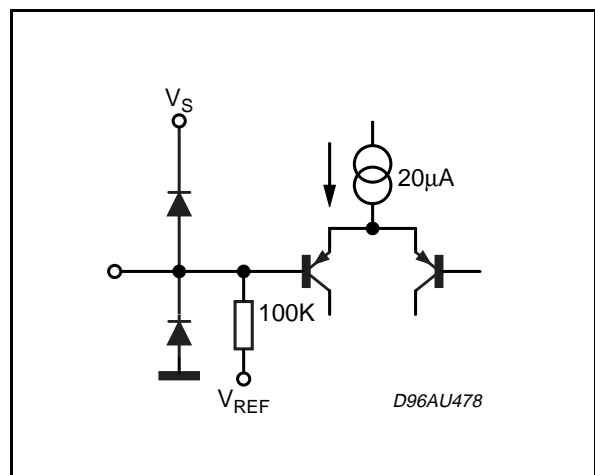

PINS: VAR-L, VAR-R,

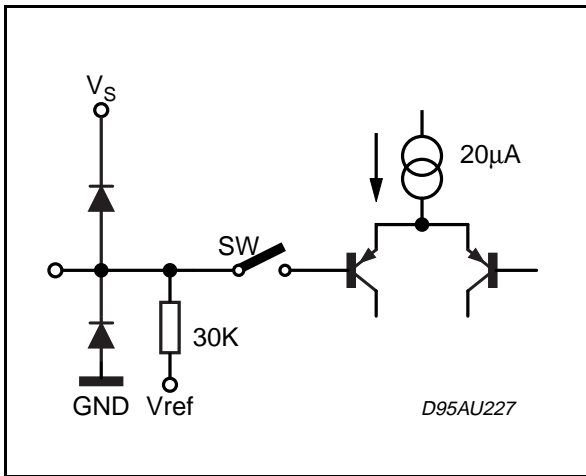

PIN: CREF

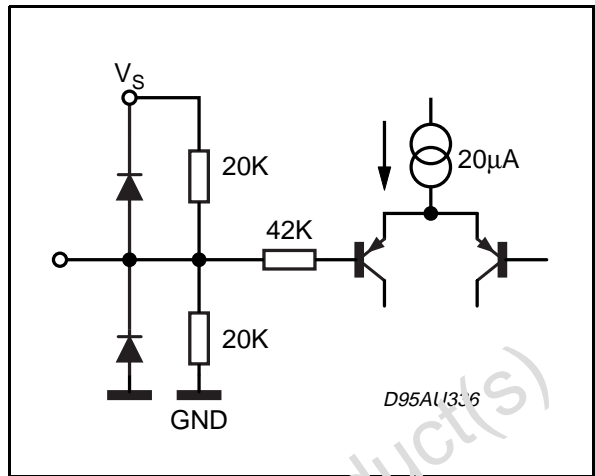

PIN: LP1

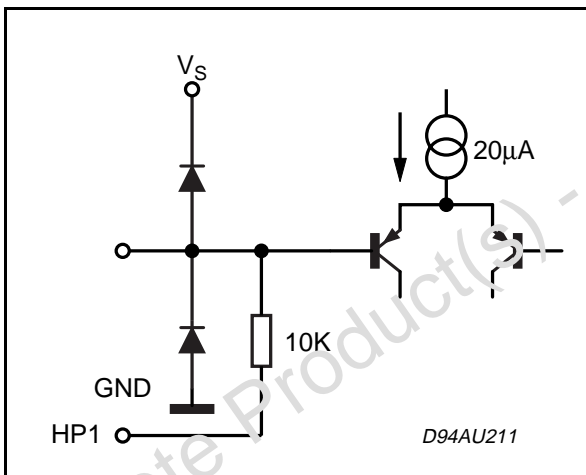

PINS: SCL, SDA

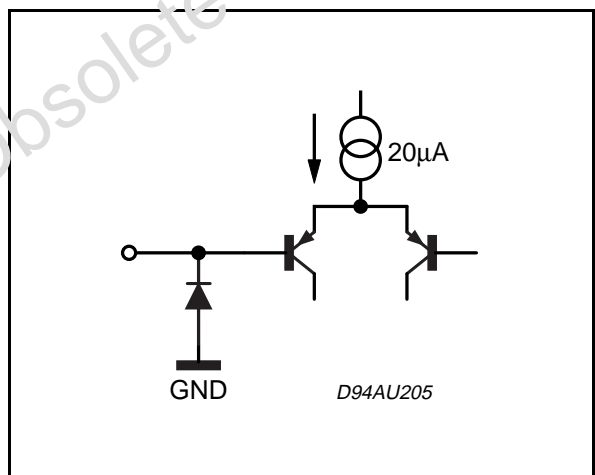

PINS: PS1, PS2, PS3, PS4, LP

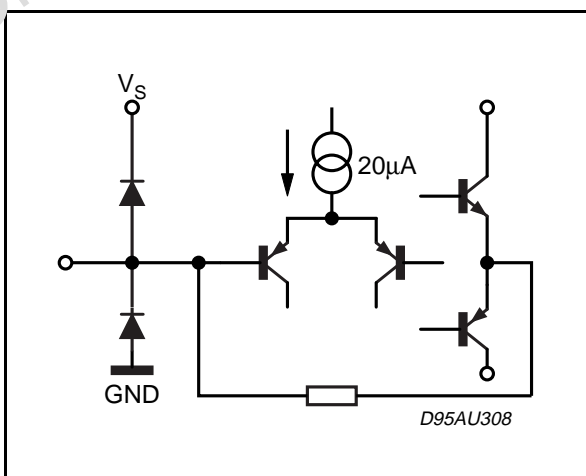

PINS: L-OUT, R-OUT, RECOU-L, RECOU-R

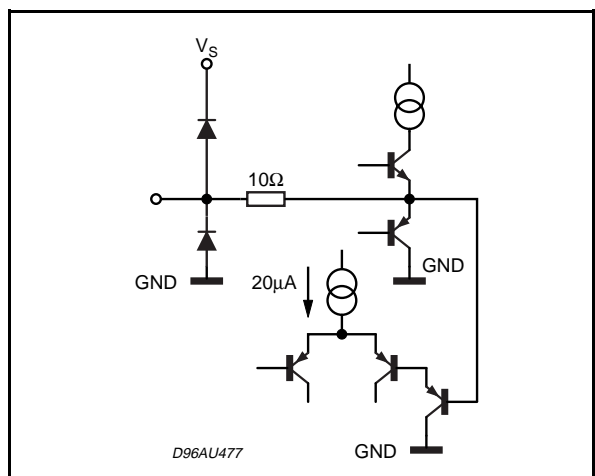

PINS: BASSO-L, BASSO-R

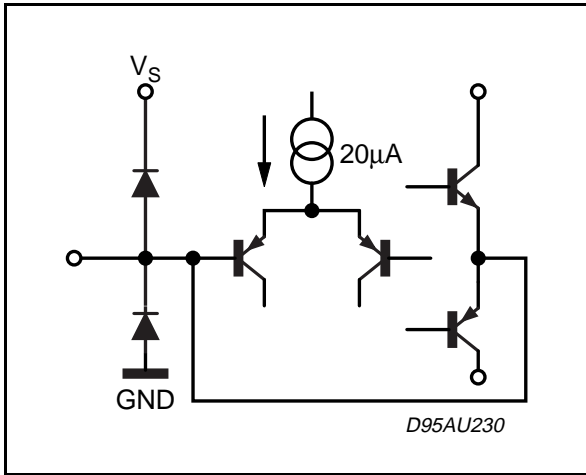

PINS: BASS-LI, BASS-RI, MIDDLE-LI, MIDDLE-RI,

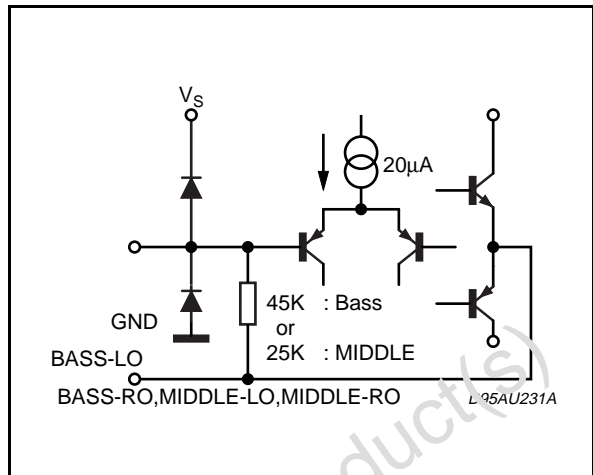

PINS: BASS-LO, BASS-RO, MIDDLE-LO, MIDDLE-

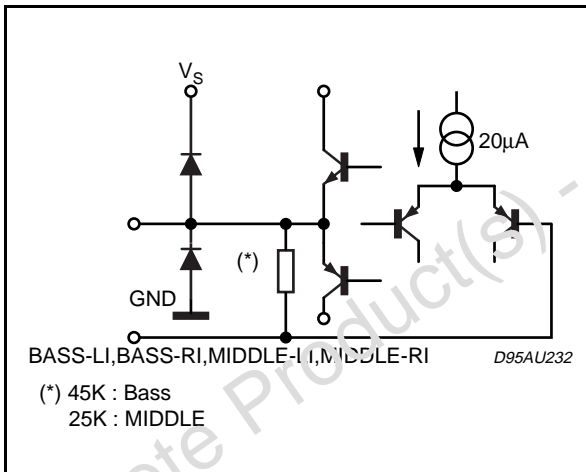

PINS: TREBLE-L, TREBLE-R

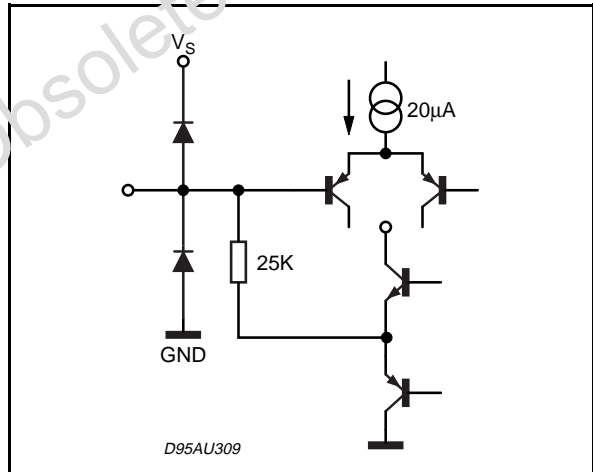

PIN: VOUT REF

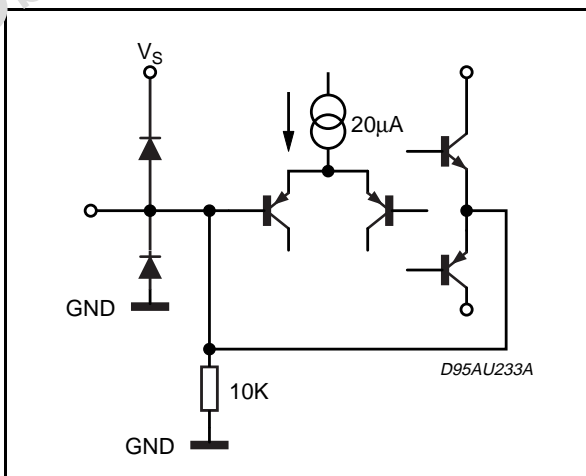

PINS: L-IN, R-IN

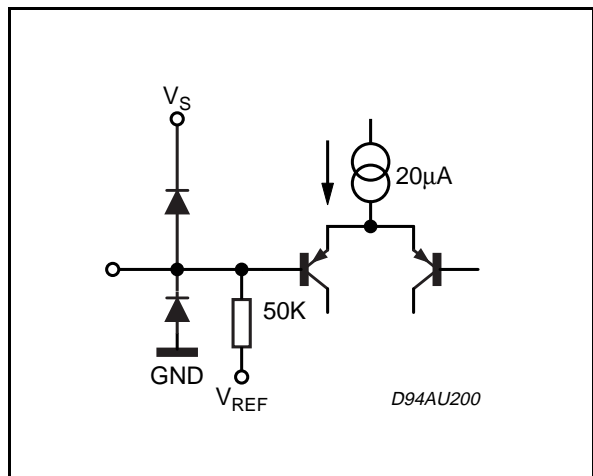

| DIM. | mm | | | inch | | |
|------|-------|-------|-------|--------|--------|--------|
| | MIN. | TYP. | MAX. | MIN. | TYP. | MAX. |
| A | | | 5.08 | | | 0.20 |
| A1 | 0.51 | | | 0.020 | | |
| A2 | 3.05 | 3.81 | 4.57 | 0.120 | 0.150 | 0.180 |
| B | 0.38 | 0.46 | 0.56 | 0.0149 | 0.0181 | 0.0220 |
| B1 | 0.89 | 1.02 | 1.14 | 0.035 | 0.040 | 0.045 |
| c | 0.23 | 0.25 | 0.38 | 0.0090 | 0.0098 | 0.0150 |
| D | 36.58 | 36.83 | 37.08 | 1.440 | 1.450 | 1.460 |
| E | 15.24 | | 16.00 | 0.60 | | 0.629 |
| E1 | 12.70 | 13.72 | 14.48 | 0.50 | 0.540 | 0.570 |
| e | | 1.778 | | | 0.070 | |
| e1 | | 15.24 | | | 0.60 | |
| e2 | | | 18.54 | | | 0.730 |
| e3 | | | 1.52 | | | 0.060 |
| L | 2.54 | 3.30 | 3.56 | 0.10 | 0.130 | 0.140 |

OUTLINE AND MECHANICAL DATA

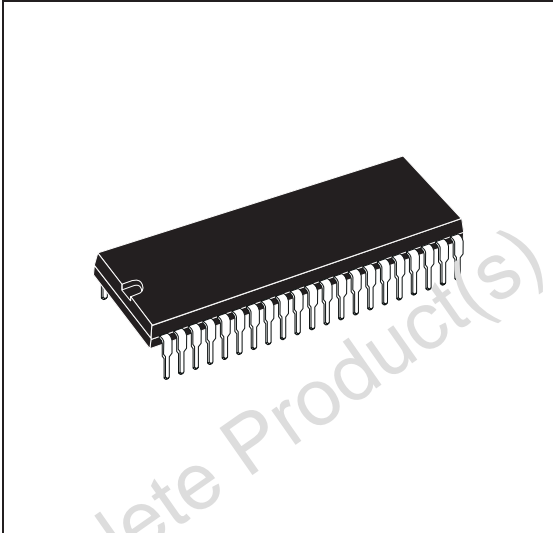

SDIP42 (0.600")

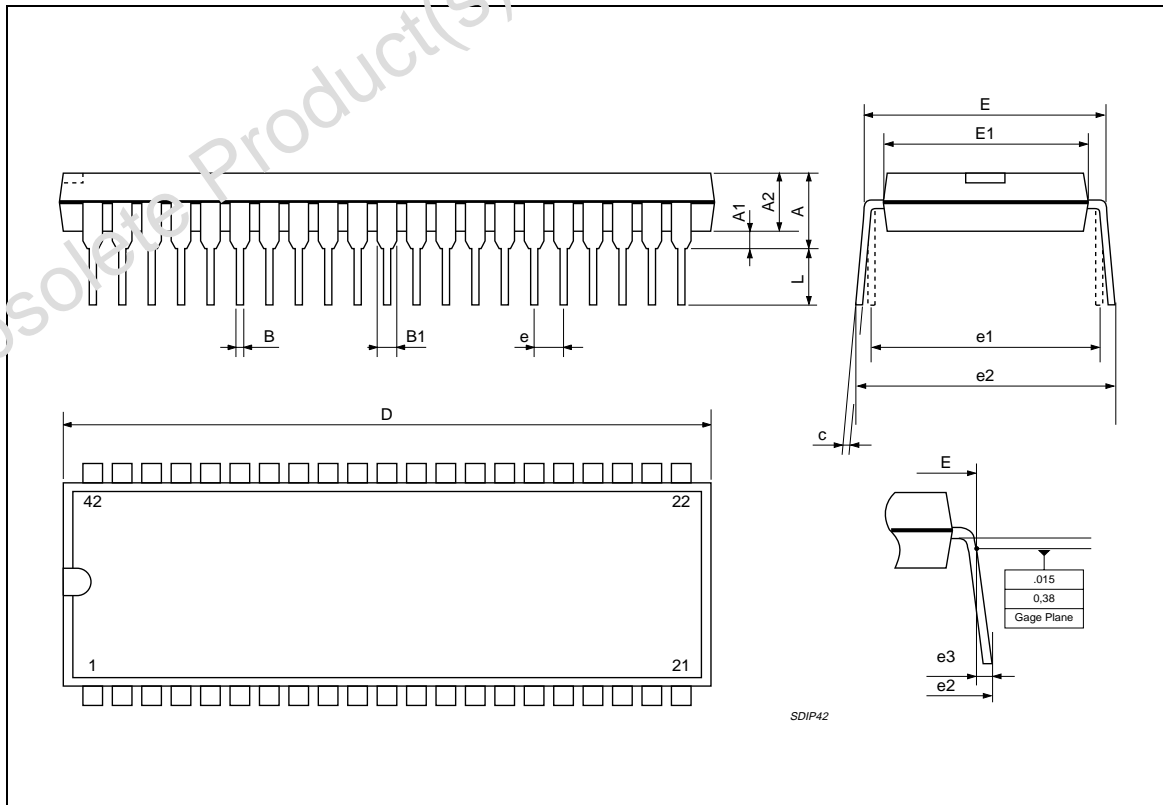

Obsolete Product(s) - Obsolete Product(s)

Information furnished is believed to be accurate and reliable. However, STMicroelectronics assumes no responsibility for the consequences of use of such information nor for any infringement of patents or other rights of third parties which may result from its use. No license is granted by implication or otherwise under any patent or patent rights of STMicroelectronics. Specifications mentioned in this publication are subject to change without notice. This publication supersedes and replaces all information previously supplied. STMicroelectronics products are not authorized for use as critical components in life support devices or systems without express written approval of STMicroelectronics.

The ST logo is a registered trademark of STMicroelectronics.
All other names are the property of their respective owners

The Sound Retrieval System and  are registered trademarks of SRS Labs, Inc.
everything else is an illusion™

STMicroelectronics GROUP OF COMPANIES

Australia – Belgium - Brazil - Canada - China – Czech Republic - Finland - France - Germany - Hong Kong - India - Israel - Italy - Japan - Malaysia - Malta - Morocco - Singapore - Spain - Sweden - Switzerland - United Kingdom - United States

www.st.com