



AK4462

117dB 768kHz 32-bit 2ch Premium DAC

1. General Description

The AK4462 is a new generation 32-bit 2ch Premium DAC which adopts VELVET SOUND™ technology. It corresponds to a 768 kHz PCM input and an DSD512 input at maximum, suitable for playback of high resolution audio sources that are becoming widespread in network audios, USB-DACs and Car Audio Systems. In addition, “OSR-Doubler” technology is adopted, making the AK4462 capable of supporting wide range signals and achieving low out-of-band noise while realizing low power consumption. Moreover, the AK4462 has six types of 32-bit digital filters, realizing simple and flexible sound making in wide range of applications.

Applications: AV Receivers, CD/SACD Players, Network Audio, Digital Audio Players, USB DACs, USB Headphones, Sound Plate/Bars, Car Audio, Automotive External Amplifiers, Measuring Instruments and Control Systems.

2. Features

- (1) Dynamic Range, S/N: 117 dB
- (2) THD+N: -107 dB
- (3) Differential Voltage Output: 5.6 Vpp
- (4) 256x Over Sampling
- (5) Sampling Rate: 8–768 kHz
- (6) 32 Bit 8x Digital Filter
 - Ripple: ± 0.0032 dB, Attenuation: 80 dB (Sharp Roll-Off Filter Setting)
 - Six Types of High Quality Sound Filter Option
 - Sharp Roll-off
 - Slow Roll-off
 - Short Delay Sharp Roll-off, (GD = 5.8/fs)
 - Short Delay Slow Roll-off, (GD = 4.8/fs)
 - Super Slow Roll-off
 - Low Dispersion Short Delay Filter
- (7) High Tolerance to Clock Jitter
- (8) Low Distortion/ Low Noise High Performance Differential Amplifier Output
- (9) DSD64, DSD128, DSD256, DSD512 Input Support
- (10) DoP64, DoP128, DoP256 Input Support
- (11) Digital De-emphasis for 32 kHz, 44.1 kHz and 48 kHz sampling
- (12) Soft Mute
- (13) Digital Attenuator (0 dB– -127 dB, 0.5 dB step)
- (14) Audio I/F Format:
 - MSB justified
 - LSB justified
 - I²S
 - DSD
 - TDM
- (15) PCM/DSD Automatic Switching Function
- (16) PCM/DoP Automatic Switching Function
- (17) 3-wire Serial and I²C μ P I/F
- (18) Supports Pin Control Mode

- (19) Master Clock:
- fs = 7.2–32 kHz: 256fs, 384fs, 512fs, 768fs, 1152fs
 - fs = 32–54 kHz: 256fs, 384fs, 512fs, 768fs
 - fs = 54–108 kHz: 256fs, 384fs
 - fs = 108–216 kHz: 128fs, 192fs
 - fs = 216–388 kHz: 32fs, 48fs, 64fs, 96fs
 - fs = 388–776 kHz: 16fs, 32fs, 48fs, 64fs
- (20) Digital Input Level: CMOS
- (21) Power Supply:
- by Internal LDO (LDOE pin = “H”): TVDD = 3.0–3.6 V, AVDD = 3.0–5.5 V
 - by external supply (LDOE pin = “L”): TVDD = 1.7–3.6 V, AVDD = 3.0–5.5 V,
VDD18 = 1.7–1.98 V
- (22) Operational Temperature: -40 to 105 °C (when the Exposed Pad is connected to AVSS)
- (23) Package: 24-pin QFN

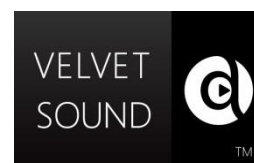

| |
|-----------------------------|
| 3. Table of Contents |
|-----------------------------|

| | | |
|-------|---|-----|
| 1. | General Description | 1 |
| 2. | Features | 1 |
| 3. | Table of Contents..... | 3 |
| 4. | Block Diagram and Functions..... | 4 |
| 4.1. | Block Diagram | 4 |
| 4.2. | Functions | 5 |
| 5. | Pin Configurations and Functions..... | 6 |
| 5.1. | Pin Configurations | 6 |
| 5.2. | Functions | 7 |
| 5.3. | Handling of Unused Pin..... | 8 |
| 6. | Absolute Maximum Ratings | 9 |
| 7. | Recommended Operating Conditions | 9 |
| 8. | Electrical Characteristics | 10 |
| 8.1. | Analog Characteristics..... | 10 |
| 8.2. | DAC Digital-Filter Characteristics (PCM mode)..... | 14 |
| 8.3. | DAC Digital-Filter Characteristics (DSD mode, DoP mode)..... | 24 |
| 8.4. | DC Characteristics..... | 25 |
| 8.5. | Switching Characteristics | 26 |
| 8.6. | Timing Diagram | 31 |
| 9. | Functional Descriptions | 35 |
| 9.1. | Control Mode | 35 |
| 9.2. | D/A Conversion Mode | 36 |
| 9.3. | System Clock..... | 41 |
| 9.4. | Audio Interface Format | 48 |
| 9.5. | Digital Filter..... | 62 |
| 9.6. | De-emphasis Filter (PCM mode)..... | 63 |
| 9.7. | Digital Attenuation | 63 |
| 9.8. | Zero Detection, DSD Full-scale Detection | 64 |
| 9.9. | LR Channel Output Signal Select, Phase Inversion Function | 68 |
| 9.10. | PCM/DSD Automatic Mode Switching Function | 69 |
| 9.11. | PCM/DoP Automatic Mode Switching Function | 73 |
| 9.12. | Soft Mute Operation | 75 |
| 9.13. | LDO..... | 76 |
| 9.14. | Power Up/Down Sequence | 77 |
| 9.15. | Power Down, Standby and Reset Function | 81 |
| 9.16. | Synchronize Function (PCM mode, DoP mode)..... | 84 |
| 9.17. | Register Control Interface | 86 |
| 9.18. | Register Map | 90 |
| 9.19. | Register Definitions | 91 |
| 10. | Recommended External Circuits..... | 97 |
| 10.1. | Recommended External Circuits..... | 97 |
| 10.2. | Grounding and Power Supply Decoupling | 99 |
| 10.3. | Reference Voltage..... | 99 |
| 10.4. | Analog Output..... | 100 |
| 11. | Package | 102 |
| 11.1. | Outline Dimensions..... | 102 |
| 11.2. | Material & Lead Finish | 102 |
| 11.3. | Marking | 102 |
| 12. | Ordering Guide | 103 |
| 13. | Revision History | 103 |
| | IMPORTANT NOTICE | 104 |

4. Block Diagram and Functions

4.1. Block Diagram

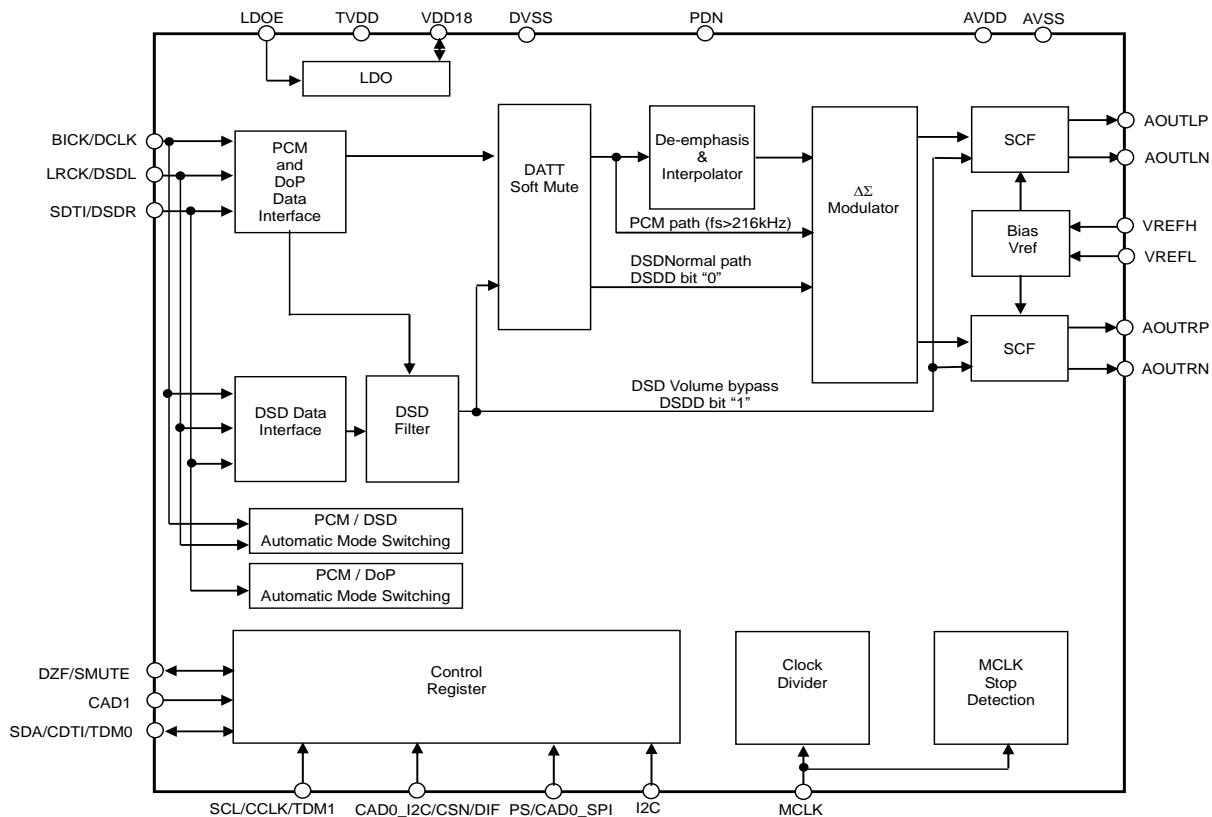

Figure 1. AK4462 Block Diagram

4.2. Functions

| Block | Function |
|------------------------------------|---|
| PCM and DoP Data Interface | Execute serial/parallel conversion of SDTI input data by synchronizing with LRCK and BICK. |
| DSD Data Interface | 1-bit data that is input from DSDL and DSDR pins is received by synchronizing with DCLK. |
| DSD Filter | FIR filter that reduces high frequency noise of DSD input data |
| PCM / DSD Automatic Mode Switching | Switch PCM/DSD modes by detecting PCM or DSD mode according to the input signal. |
| PCM / DoP Automatic Mode Switching | Switch PCM/DoP modes by detecting PCM or DoP mode according to the input signal. |
| DATT, Soft Mute | Apply DATT and Soft Mute process to input data. |
| $\Delta\Sigma$ Modulator | Output multi-bit data to SCF. This block consists of a third-order digital delta-sigma modulator. |
| De-emphasis & Interpolator | A digital filter that applies De-emphasis process to input data and executes over sampling. |
| SCF | A primary switched capacitor filter that converts a multi-bit output of $\Delta\Sigma$ modulator to an analog signal. |
| Control Register | Keep register settings for each mode. Control registers are accessed in 3-wire (CSN, CCLK, CDTI) or I ² C-Bus (SCL, SDA) control mode. |
| Clock Divider | Divide Master Clock In PCM mode, master clock is divided automatically by fs rate auto detection function. In DSD mode, the master clock frequency is set by DCKS bit. |
| MCLK Stop Detection | Detects when the master clock input is absent. |
| Bias, Vref | Generate SCF reference voltage from the reference voltage (VREFH, VREFL) that are externally supplied. |
| LDO | Generate power for internal digital circuit (1.8 V Typ.). |

5. Pin Configurations and Functions

5.1. Pin Configurations

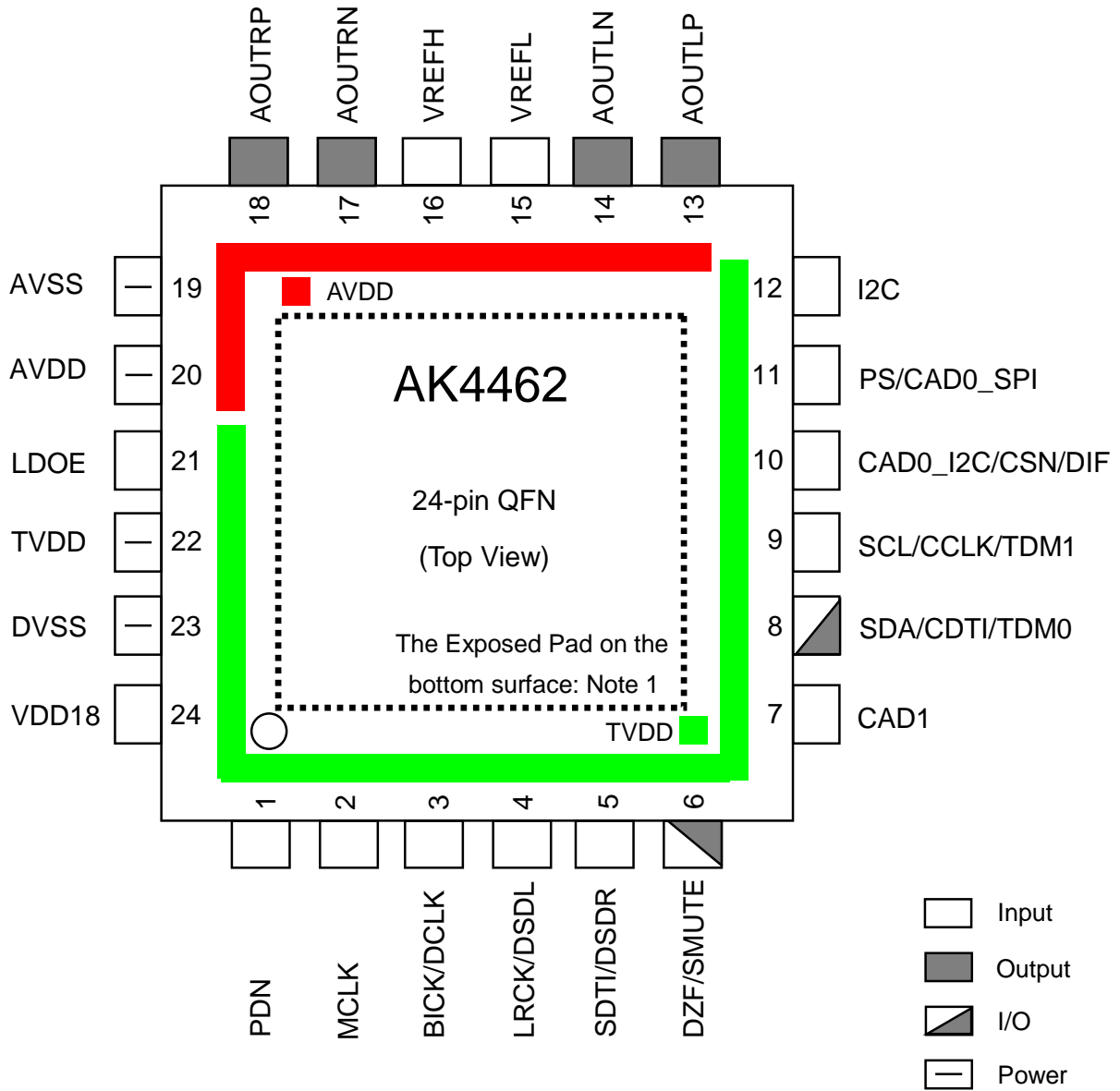

Note 1. The Exposed Pad on the bottom surface of the package must be open or connected to AVSS. Do not connect this pin to other signal lines.

5.2. Functions

| No. | Pin Name | I/O | Function | Power Down State |
|-----|-------------|-----|---|----------------------------|
| 1 | PDN | I | Power-Up, Power-Down Pin When at "L", the AK4462 is in power-down mode. The AK4462 must always be in power-down mode upon power-on. | Hi-Z |
| 2 | MCLK | I | External Master Clock Input Pin | Hi-Z |
| 3 | BICK | I | Audio Serial Data Clock Pin in PCM mode and DoP mode | Hi-Z |
| | DCLK | I | DSD Clock Pin in DSD mode | |
| 4 | LRCK | I | Input Channel Clock Pin in PCM mode and DoP mode | Hi-Z |
| | DSDL | I | Audio Serial Data Input in DSD mode | |
| 5 | SDTI | I | Audio Serial Data Input in PCM mode and DoP mode | Hi-Z |
| | DSDR | I | Audio Serial Data Input in DSD mode | |
| 6 | DZF | O | Zero Input Detect in Register control mode | Pull-Down To DVSS (100 kΩ) |
| | SMUTE | I | Soft Mute Pin in Pin control mode. When this pin is changed to "H", soft mute cycle is initiated. When returning "L", the output mute releases. | |
| 7 | CAD1 | I | Chip Address 1 Pin in Register control mode | Hi-Z |
| 8 | SDA | I/O | Control Data Pin in I ² C Bus Register control mode | Hi-Z |
| | CDTI | I | Control Data Input Pin in 3-wire serial Register control mode | |
| | TDM0 | I | TDM Mode select pin in Pin control mode. | |
| 9 | SCL | I | Control Data Clock Pin in I ² C Bus Register control mode | Hi-Z |
| | CCLK | I | Control Data Clock Pin in 3-wire serial Register control mode | |
| | TDM1 | I | TDM Mode select pin in Pin control mode. | |
| 10 | CAD0_I2C | I | Chip Address 0 Pin in I ² C Bus Register control mode | Hi-Z |
| | CSN | I | Chip Select Pin in 3-wire serial Register control mode | |
| | DIF | I | Audio Data Format Select in Pin control mode. "L": 32-bit MSB, "H": 32-bit I ² S | |
| 11 | PS | I | Control Mode Select Pin (I ² C pin = "H") "L": I ² C Bus Register control mode, "H": Pin control mode. | Hi-Z |
| | CAD0_SPI | I | (I ² C pin = "L") Chip Address 0 Pin in 3-wire serial Register control mode | |
| 12 | I2C | I | Control Mode Select Pin "L": 3-wire serial Register control mode "H": I ² C Bus Register control mode or Pin control mode. | Hi-Z |
| 13 | AOUTLP | O | Lch Positive Analog Output Pin | Hi-Z |
| 14 | AOUTLN | O | Lch Negative Analog Output Pin | Hi-Z |
| 15 | VREFL | I | Negative Reference Voltage Input Pin | Hi-Z |
| 16 | VREFH | I | Positive Reference Voltage Input Pin | Hi-Z |
| 17 | AOUTRN | O | Rch Negative Analog Output Pin | Hi-Z |
| 18 | AOUTRP | O | Rch Positive Analog Output Pin | Hi-Z |
| 19 | AVSS | - | Analog Ground Pin | - |
| 20 | AVDD | - | Analog Power Supply Pin, 3.0–5.5 V | - |
| 21 | LDOE | I | Internal LDO Enable Pin. "L": Disable, "H": Enable | Hi-Z |
| 22 | TVDD | - | Digital Power Supply Pin, 3.0–3.6 V | - |
| 23 | DVSS | - | Digital Ground Pin | - |
| 24 | VDD18 | O | LDO Output Pin. (LDOE pin = "H") This pin should be connected to DVSS with 1.0 μF (±50 %). This pin is prohibited from connecting with other devices. | Pull-down to DVSS (500 Ω) |
| | | - | 1.8 V Power Input Pin (LDOE pin = "L") | - |
| - | Exposed Pad | - | The Exposed Pad on the bottom surface of the package must be open or connected to AVSS. Do not connect this pin to other signal lines. | - |

Note 2. All input pins except internal pull-up/down pins must not be left floating.

Note 3. The AK4462 must be powered down by the PDN pin when changing the PS pin and the I2C pin settings.

Note 4. DSD mode and DoP mode are selectable only in Register Control Mode.

5.3. Handling of Unused Pin

5.3.1. Pin Control Mode (PCM Mode only)

| Classification | Pin Name | Setting |
|----------------|--------------------|-----------------|
| Analog | AOUTLP/N, AOUTRP/N | Open |
| Digital | CAD1 | Connect to DVSS |

5.3.2. Register Control Mode

| Classification | Pin Name | Setting |
|----------------|--------------------|---------|
| Analog | AOUTLP/N, AOUTRP/N | Open |
| Digital | DZF | Open |

5.3.3. Pull-down pin List

| Classification | Pin Name | Internal connection |
|----------------------------------|----------|---------------------|
| pull-down pin (Typ. = 100 kΩ) | SMUTE | DVSS |

6. Absolute Maximum Ratings

(AVSS = DVSS = 0 V; Note 5)

| Parameter | | Symbol | Min. | Max. | Unit |
|--|--------------------------------|--------------|----------|-----------------|------|
| Power Supplies | Analog | AVDD | -0.3 | 6.0 | V |
| | Digital I/O | TVDD | -0.3 | 4.0 | V |
| | Digital Core | VDD18 | -0.3 | 2.5 | V |
| | AVSS - DVSS (Note 6) | Δ GND | - | 0.3 | V |
| Reference Voltage | High VREF (Note 7) | VREFH | AVSS-0.3 | AVDD+0.3 or 6.0 | V |
| | Low VREF | VREFL | AVSS-0.3 | AVSS+0.3 | V |
| Input Current, Any Pin Except Supplies | | IIN | - | \pm 10 | mA |
| Digital Input Voltage (Note 8) | | VIND | -0.3 | TVDD+0.3 or 4.0 | V |
| Ambient Temperature (Power applied) | | | | | |
| | Exposed Pad: Connected to AVSS | Ta | -40 | 105 | °C |
| | Exposed Pad: Open | Ta | -40 | 85 | °C |
| Storage Temperature | | Tstg | -65 | 150 | °C |

Note 5. All voltages are with respect to ground.

Note 6. AVSS and DVSS must be connected to the same analog ground plane.

Note 7. Maximum input voltage of VREFH pin is lower value between (AVDD+0.3) V and 6.0 V.

Note 8. Maximum input voltage of digital input pins is lower value between (TVDD+0.3) V and 4.0 V.

**WARNING: Operation at or beyond these limits may result in permanent damage to the device.
Normal operation is not guaranteed at these extremes.**

7. Recommended Operating Conditions

(AVSS = DVSS = 0 V; Note 5)

| Parameter | | Symbol | Min. | Typ. | Max. | Unit |
|-------------------|---------------------------|--------|----------|------|------|------|
| Power Supplies | (LDOE pin = "L"; Note 9) | | | | | |
| | Analog | AVDD | 3.0 | 5.0 | 5.5 | V |
| | Digital I/O | TVDD | VDD18 | 1.8 | 3.6 | V |
| | Digital Core | VDD18 | 1.7 | 1.8 | 1.98 | V |
| | (LDOE pin = "H"; Note 10) | | | | | |
| | Analog | AVDD | 3.0 | 5.0 | 5.5 | V |
| | Digital I/O | TVDD | 3.0 | 3.3 | 3.6 | V |
| Reference Voltage | High VREF (Note 11) | VREFH | AVDD-0.5 | - | AVDD | V |
| | Low VREF | VREFL | - | AVSS | - | V |

Note 9. When the LDOE pin = "L", VDD18 must be supplied at the same time as or after TVDD. The power up sequence between AVDD and TVDD or AVDD and VDD18 is not critical.

Note 10. When the LDOE pin = "H", the internal LDO supplies 1.8 V (Typ.). The power up sequence between AVDD and TVDD is not critical.

Note 11. VREFH must be input at the same time as or after AVDD.

8. Electrical Characteristics

8.1. Analog Characteristics

8.1.1. PCM mode (AVDD = 5.0 V)

(Ta = 25 °C: LDOE pin = "H", TVDD = 3.3 V, AVDD = 5.0 V: AVSS = DVSS = 0 V: VREFH = 5.0 V, VREFL = 0 V: fs = 44.1 kHz: BICK = 64 fs: Signal Frequency = 1 kHz: 32-bit Input Data: RL ≥ 1.4 kΩ: measurement bandwidth = 20 Hz–20 kHz: External Circuit: (Figure 81): unless otherwise specified.)

| Parameter | Min. | Typ. | Max. | Unit | | |
|---|----------------------|----------|------|------|--------|----|
| Resolution | - | - | 32 | bit | | |
| Dynamic Characteristics (Note 12) | | | | | | |
| THD+N | fs = 44.1 kHz | 0 dBFS | - | -107 | -100 | dB |
| | BW = 20 kHz | -60 dBFS | - | -54 | - | dB |
| | fs = 96 kHz | 0 dBFS | - | -104 | - | dB |
| | BW = 40 kHz | -60 dBFS | - | -50 | - | dB |
| Dynamic Range (-60 dBFS with A-weighted) (Note 13) | fs = 192/384/768 kHz | 0 dBFS | - | -104 | - | dB |
| | BW = 80 kHz | -60 dBFS | - | -46 | - | dB |
| S/N (A-weighted) | 112 | 117 | - | - | dB | |
| Interchannel Isolation (1kHz) | 100 | 110 | - | - | dB | |
| DC Accuracy | | | | | | |
| Interchannel Gain Mismatch | - | 0 | 0.3 | - | dB | |
| Gain Drift | (Note 14) | - | 20 | - | ppm/°C | |
| Differential Output Voltage | (Note 15) | 5.3 | 5.6 | 5.9 | Vpp | |
| Load Resistance | (Note 16) | 1.4 | - | - | kΩ | |
| Load Capacitance | (Note 17) | - | - | 30 | pF | |
| Power Supplies | | | | | | |
| Power Supply Current | | | | | | |
| Normal operation (PDN pin = "H") (LDOE pin = "L", VDD18 = 1.8 V) | | | | | | |
| AVDD | - | 12 | 17 | mA | | |
| TVDD | - | 1 | 1.2 | mA | | |
| VDD18 (fs = 44.1 kHz) | - | 2 | 3 | mA | | |
| VDD18 (fs = 96 kHz) | - | 3.5 | 5.5 | mA | | |
| VDD18 (fs = 192 kHz) | - | 6 | 9 | mA | | |
| VDD18 (fs = 384 kHz) | - | 2 | - | mA | | |
| VDD18 (fs = 768 kHz) | - | 3 | - | mA | | |
| (LDOE pin = "H") | | | | | | |
| AVDD | - | 12 | 17 | mA | | |
| TVDD (fs = 44.1 kHz) | - | 3 | 4.5 | mA | | |
| TVDD (fs = 96 kHz) | - | 4.5 | 7 | mA | | |
| TVDD (fs = 192 kHz) | - | 7 | 10 | mA | | |
| TVDD (fs = 384 kHz) | - | 3 | - | mA | | |
| TVDD (fs = 768 kHz) | - | 4 | - | mA | | |
| Power down (PDN pin = "L") (Note 18) | | | | | | |
| AVDD+TVDD (Ta = 105 °C) | - | 1 | 100 | μA | | |
| AVDD+TVDD (Ta = 25 °C) | - | 1 | 10 | μA | | |
| VREF Supplies | | | | | | |
| VREF Supply Current | | | | | | |
| Normal operation (PDN pin = "H") | - | 0.1 | 0.3 | mA | | |

Note 12. Measured by Audio Precision APx555, averaging mode.

Note 13. When using the circuit shown in Figure 81. 100 dB at 16-bit data

Note 14. The voltage of (VREFH–VREFL) is held at 5 V.

Note 15. The output voltage scale with the voltage of (VREFH–VREFL).

$$AOUTL/R(\text{Typ. @0dB}) = (AOUTLP/RP) - (AOUTLN/RN) = 1.12V_{pp} \times (VREFH - VREFL)$$

Note 16. The load resistance value is without a DC cut capacitor, and is with respect to ground. The AC load is 1.0 k Ω (Min.) with a DC cut capacitor.

Note 17. Load Capacitance value is with respect to ground.

Note 18. All other digital input pins including clock pins, (MCLK, BICK and LRCK), are held to DVSS.

8.1.2. PCM mode (AVDD = 3.3 V)

(Ta = 25 °C: LDOE pin = "H", TVDD = 3.3 V, AVDD = 3.3 V: AVSS = DVSS = 0 V: VREFH = 3.3 V, VREFL = 0 V: fs = 44.1 kHz: BICK = 64 fs: Signal Frequency = 1 kHz: 32-bit Input Data: RL ≥ 1.4 kΩ: measurement bandwidth = 20 Hz–20 kHz: External Circuit: (Figure 81): unless otherwise specified.)

| Parameter | Min. | Typ. | Max. | Unit | | |
|---|----------------------|----------|------|------|--------|----|
| Resolution | - | - | 32 | bit | | |
| Dynamic Characteristics (Note 12) | | | | | | |
| THD+N | fs = 44.1 kHz | 0 dBFS | - | -100 | -93 | dB |
| | BW = 20 kHz | -60 dBFS | - | -50 | - | dB |
| | fs = 96 kHz | 0 dBFS | - | -99 | - | dB |
| | BW = 40 kHz | -60 dBFS | - | -46 | - | dB |
| Dynamic Range (-60dBFS with A-weighted) | fs = 192/384/768 kHz | 0 dBFS | - | -99 | - | dB |
| | BW = 80 kHz | -60 dBFS | - | -42 | - | dB |
| S/N (A-weighted) | 108 | 113 | - | - | dB | |
| Interchannel Isolation (1kHz) | 100 | 110 | - | - | dB | |
| DC Accuracy | | | | | | |
| Interchannel Gain Mismatch | - | 0 | 0.3 | - | dB | |
| Gain Drift | (Note 19) | - | 20 | - | ppm/°C | |
| Differential Output Voltage | (Note 15) | 3.32 | 3.7 | 4.08 | Vpp | |
| Load Resistance | (Note 16) | 1.4 | - | - | kΩ | |
| Load Capacitance | (Note 17) | - | - | 30 | pF | |
| Power Supplies | | | | | | |
| Power Supply Current | | | | | | |
| Normal operation (PDN pin = "H") (LDOE pin = "L", VDD18 = 1.8 V) | | | | | | |
| AVDD | - | 10 | 14 | mA | | |
| TVDD | - | 1 | 1.2 | mA | | |
| VDD18 (fs = 44.1 kHz) | - | 2 | 3 | mA | | |
| VDD18 (fs = 96 kHz) | - | 3.5 | 5.5 | mA | | |
| VDD18 (fs = 192 kHz) | - | 6 | 9 | mA | | |
| VDD18 (fs = 384 kHz) | - | 2 | - | mA | | |
| VDD18 (fs = 768 kHz) | - | 3 | - | mA | | |
| (LDOE pin = "H" C) | | | | | | |
| AVDD | - | 10 | 14 | mA | | |
| TVDD (fs = 44.1 kHz) | - | 3 | 4.5 | mA | | |
| TVDD (fs = 96 kHz) | - | 4.5 | 7 | mA | | |
| TVDD (fs = 192 kHz) | - | 7 | 10 | mA | | |
| TVDD (fs = 384 kHz) | - | 3 | - | mA | | |
| TVDD (fs = 768 kHz) | - | 4 | - | mA | | |
| Power down (PDN pin = "L") (Note 18) | | | | | | |
| AVDD+TVDD (Ta = 105 °C) | - | 1 | 100 | μA | | |
| AVDD+TVDD (Ta = 25 °C) | - | 1 | 10 | μA | | |
| VREF Supplies | | | | | | |
| VREF Supply Current | | | | | | |
| Normal operation (PDN pin = "H") | - | 0.1 | 0.3 | mA | | |

Note 19. The voltage of (VREFH–VREFL) is held at 3.3 V.

8.1.3. DSD Mode, DoP Mode

(Ta = 25 °C: LDOE pin = "H", TVDD = 3.3V, AVDD = 5.0 V: AVSS = DVSS = 0 V: VREFH = 5.0 V, VREFL = 0 V: fs = 44.1 kHz: Signal Frequency = 1 kHz: RL ≥ 1.4 kΩ: measurement bandwidth = 20 Hz–20 kHz: External Circuit: (Figure 81): unless otherwise specified.)

| Dynamic Characteristics (Note 12) | | | | | | |
|---|--|--------------------------|------|------|------|------|
| Parameter | | | Min. | Typ. | Max. | Unit |
| THD+N | DSD data stream: DSD64 DoP data stream: DoP64 | 0 dB (Note 20) | - | -107 | - | dB |
| | DSD data stream: DSD128 DoP data stream: DoP128 | 0 dB (Note 20) | - | -107 | - | dB |
| | DSD data stream: DSD256 DoP data stream: DoP256 | 0 dB (Note 20) | - | -107 | - | dB |
| | DSD data stream: DSD512 | 0 dB (Note 20) | - | -107 | - | dB |
| S/N (A-weighted, Normal path) | DSD data stream: DSD64 DoP data stream: DoP64 | Digital "0" (Note 21) | - | 116 | - | dB |
| | DSD data stream: DSD128 DoP data stream: DoP128 | Digital "0" (Note 21) | - | 116 | - | dB |
| | DSD data stream: DSD256 DoP data stream: DoP256 | Digital "0" (Note 21) | - | 116 | - | dB |
| | DSD data stream: DSD512 | Digital "0" (Note 21) | - | 116 | - | dB |
| DC Accuracy | | | | | | |
| Differential Output Voltage (Normal path) (Note 22) | | | - | 5.0 | - | Vpp |
| Differential Output Voltage (Volume Bypass) (Note 22) | | | - | 5.0 | - | Vpp |

Note 20. The output level is assumed as 0 dB when a 1 kHz 25–75% duty sine wave is input. Click noise may occur if the input signal exceeds 0 dB.

Note 21. Digital "0" is a "01101001" digital zero code pattern.

Note 22. The analog output voltage at 25–75% input signal duty is calculated by the following equation:

$$AOUTL/R (Typ.@0dB) = (AOUTLP/RP) - (AOUTLN/RN) = 1.0Vpp \times (VREFH - VREFL)$$

8.2. DAC Digital-Filter Characteristics (PCM mode)

8.2.1. Sharp Roll-Off Filter Characteristics

(Ta = -40–105 °C: AVDD = 3.0–5.5 V, TVDD = 1.7–3.6 V: DEM[1:0] bits = “01”(OFF): ADPE bit = “0”, SYNCE bit = “1”, SLOW bit = “0”, SD bit = “0”, SSLOW bit = “0”)

• fs = 44.1 kHz (Normal Speed Mode)

| Parameter | | Symbol | Min. | Typ. | Max. | Unit |
|---------------------------------------|-----------|--------|------|------|---------|------|
| Digital Filter | | | | | | |
| Frequency Response (Note 23) | ±0.05 dB | - | 0 | - | 20.0 | kHz |
| | -3.0 dB | - | - | 21.5 | - | kHz |
| Pass band | (Note 24) | PB | 0 | - | 20.0 | kHz |
| Stop band | (Note 24) | SB | 24.1 | - | - | kHz |
| Pass band Ripple | (Note 25) | PR | - | - | ±0.0032 | dB |
| Stop band Attenuation | (Note 23) | SA | 80 | - | - | dB |
| Group Delay | (Note 26) | GD | - | 26.8 | - | 1/fs |
| Digital Filter + SCF (Note 23) | | | | | | |
| Frequency Response: 0–20.0 kHz | | | -0.2 | - | 0.1 | dB |

• fs = 96 kHz (Double Speed Mode)

| Parameter | | Symbol | Min. | Typ. | Max. | Unit |
|---------------------------------------|-----------|--------|------|------|---------|------|
| Digital Filter | | | | | | |
| Frequency Response (Note 23) | ±0.05 dB | - | 0 | - | 43.5 | kHz |
| | -3.0 dB | - | - | 46.8 | - | kHz |
| Pass band | (Note 24) | PB | 0 | - | 43.5 | kHz |
| Stop band | (Note 24) | SB | 52.5 | - | - | kHz |
| Pass band Ripple | (Note 25) | PR | - | - | ±0.0032 | dB |
| Stop band Attenuation | (Note 23) | SA | 80 | - | - | dB |
| Group Delay | (Note 26) | GD | - | 26.8 | - | 1/fs |
| Digital Filter + SCF (Note 23) | | | | | | |
| Frequency Response: 0–40.0 kHz | | | -0.6 | - | 0.1 | dB |

• fs = 192 kHz (Quad Speed Mode)

| Parameter | | Symbol | Min. | Typ. | Max. | Unit |
|---------------------------------------|-----------|--------|------|------|---------|------|
| Digital Filter | | | | | | |
| Frequency Response (Note 23) | ±0.05 dB | - | 0 | - | 87.0 | kHz |
| | -3.0 dB | - | - | 93.6 | - | kHz |
| Pass band | (Note 24) | PB | 0 | - | 87.0 | kHz |
| Stop band | (Note 24) | SB | 105 | - | - | kHz |
| Pass band Ripple | (Note 25) | PR | - | - | ±0.0032 | dB |
| Stop band Attenuation | (Note 23) | SA | 80 | - | - | dB |
| Group Delay | (Note 26) | GD | - | 26.8 | - | 1/fs |
| Digital Filter + SCF (Note 23) | | | | | | |
| Frequency Response: 0–80.0 kHz | | | -2.0 | - | 0.1 | dB |

Note 23. Frequency response refers to the output level of 1 kHz. Stopband attenuation band ranges from SB to fs.

Note 24. The passband and stopband frequencies scale with fs. For example, PB = 0.454 × fs (@ ±0.05 dB), SB = 0.546 × fs.

Note 25. This value is the gain amplitude in pass band width.

Note 26. The calculating delay time which occurred by digital filtering. This value is from setting the 16/20/24/32-bit data of both channels to the output of analog signal.

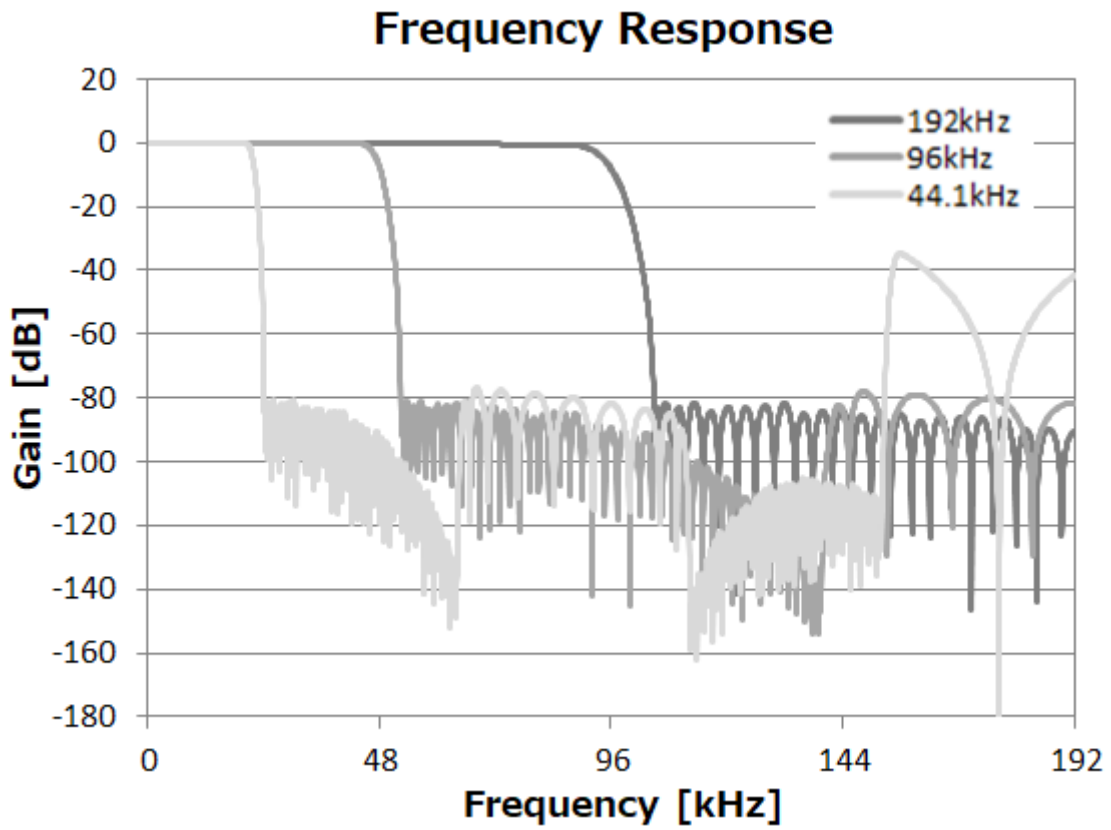

Figure 2. Sharp Roll-off Filter Frequency Response

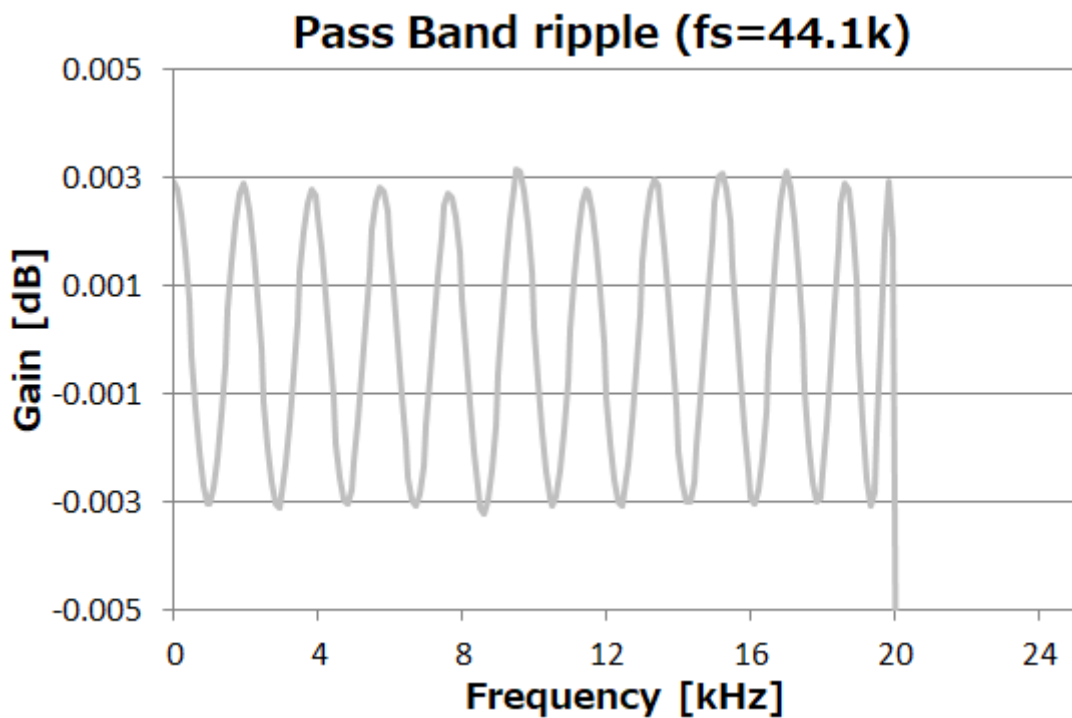

Figure 3. Sharp Roll-off Filter Passband Ripple

8.2.2. Slow Roll-Off Filter Characteristics

(Ta = -40–105 °C: AVDD = 3.0–5.5 V, TVDD = 1.7–3.6 V: DEM[1:0] bits = “01”(OFF): ADPE bit = “0”, SYNCE bit = “1”, SLOW bit = “1”, SD bit = “0”, SSLOW bit = “0”)

• fs = 44.1 kHz (Normal Speed Mode)

| Parameter | | Symbol | Min. | Typ. | Max. | Unit |
|---------------------------------------|-----------|--------|------|------|--------|------|
| Digital Filter | | | | | | |
| Frequency Response (Note 23) | ±0.05 dB | - | 0 | - | 8.1 | kHz |
| | -3.0 dB | - | - | 18.2 | - | kHz |
| Pass band | (Note 27) | PB | 0 | - | 8.1 | kHz |
| Stop band | (Note 27) | SB | 39.2 | - | - | kHz |
| Pass band Ripple | (Note 25) | PR | - | - | ±0.043 | dB |
| Stop band Attenuation | (Note 23) | SA | 73 | - | - | dB |
| Group Delay | (Note 26) | GD | - | 6.3 | - | 1/fs |
| Digital Filter + SCF (Note 23) | | | | | | |
| Frequency Response: 0–20.0 kHz | | | -5.0 | - | +0.1 | dB |

• fs = 96 kHz (Double Speed Mode)

| Parameter | | Symbol | Min. | Typ. | Max. | Unit |
|---------------------------------------|-----------|--------|------|------|--------|------|
| Digital Filter | | | | | | |
| Frequency Response (Note 23) | ±0.05 dB | - | 0 | - | 17.7 | kHz |
| | -3.0 dB | - | - | 39.5 | - | kHz |
| Pass band | (Note 27) | PB | 0 | - | 17.7 | kHz |
| Stop band | (Note 27) | SB | 85.3 | - | - | kHz |
| Pass band Ripple | (Note 25) | PR | - | - | ±0.043 | dB |
| Stop band Attenuation | (Note 23) | SA | 73 | - | - | dB |
| Group Delay | (Note 26) | GD | - | 6.3 | - | 1/fs |
| Digital Filter + SCF (Note 23) | | | | | | |
| Frequency Response: 0–40.0 kHz | | | -5.0 | - | +0.1 | dB |

• fs = 192 kHz (Quad Speed Mode)

| Parameter | | Symbol | Min. | Typ. | Max. | Unit |
|---------------------------------------|-----------|--------|------|------|--------|------|
| Digital Filter | | | | | | |
| Frequency Response (Note 23) | ±0.05 dB | - | 0 | - | 35.5 | kHz |
| | -3.0 dB | - | - | 79.0 | - | kHz |
| Pass band | (Note 27) | PB | 0 | - | 35.5 | kHz |
| Stop band | (Note 27) | SB | 171 | - | - | kHz |
| Pass band Ripple | (Note 25) | PR | - | - | ±0.043 | dB |
| Stop band Attenuation | (Note 23) | SA | 73 | - | - | dB |
| Group Delay | (Note 26) | GD | - | 6.3 | - | 1/fs |
| Digital Filter + SCF (Note 23) | | | | | | |
| Frequency Response: 0–80.0 kHz | | | -5.0 | - | +0.1 | dB |

Note 27. The passband and stopband frequencies scale with fs. For example, PB = 0.184 × fs (@ ±0.05 dB), SB = 0.888 × fs.

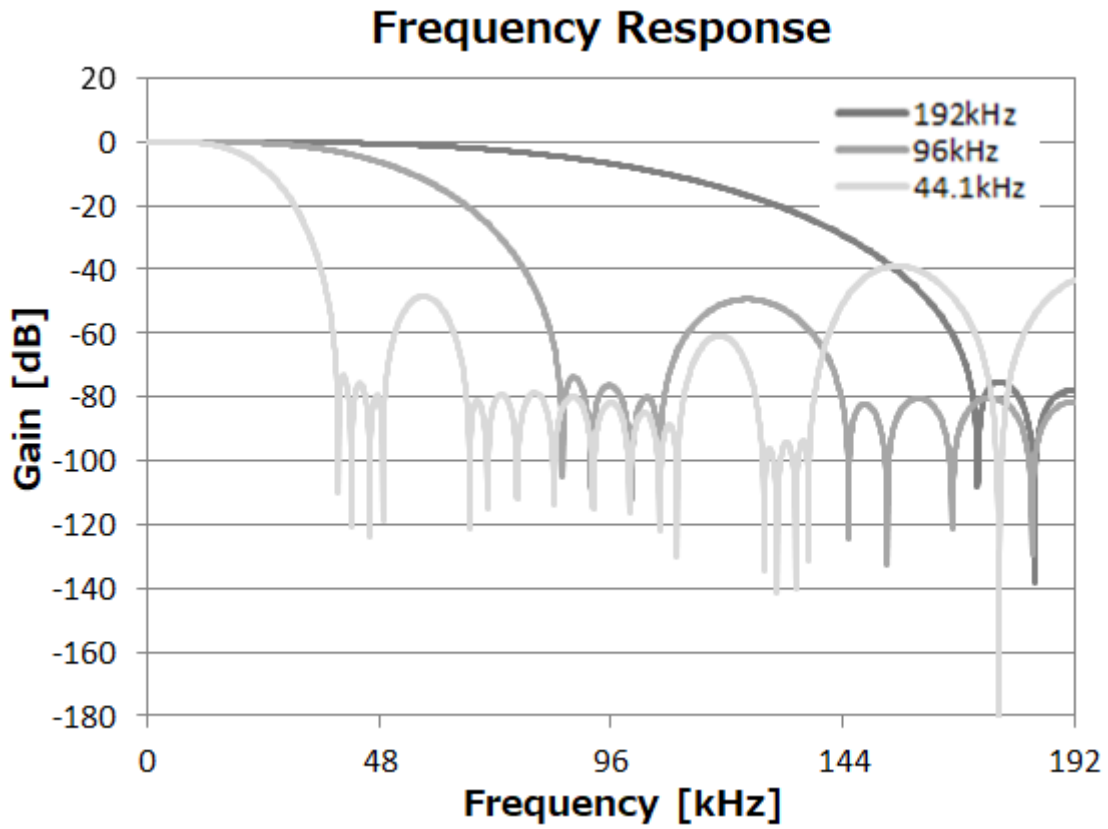

Figure 4. Slow Roll-off Filter Frequency Response

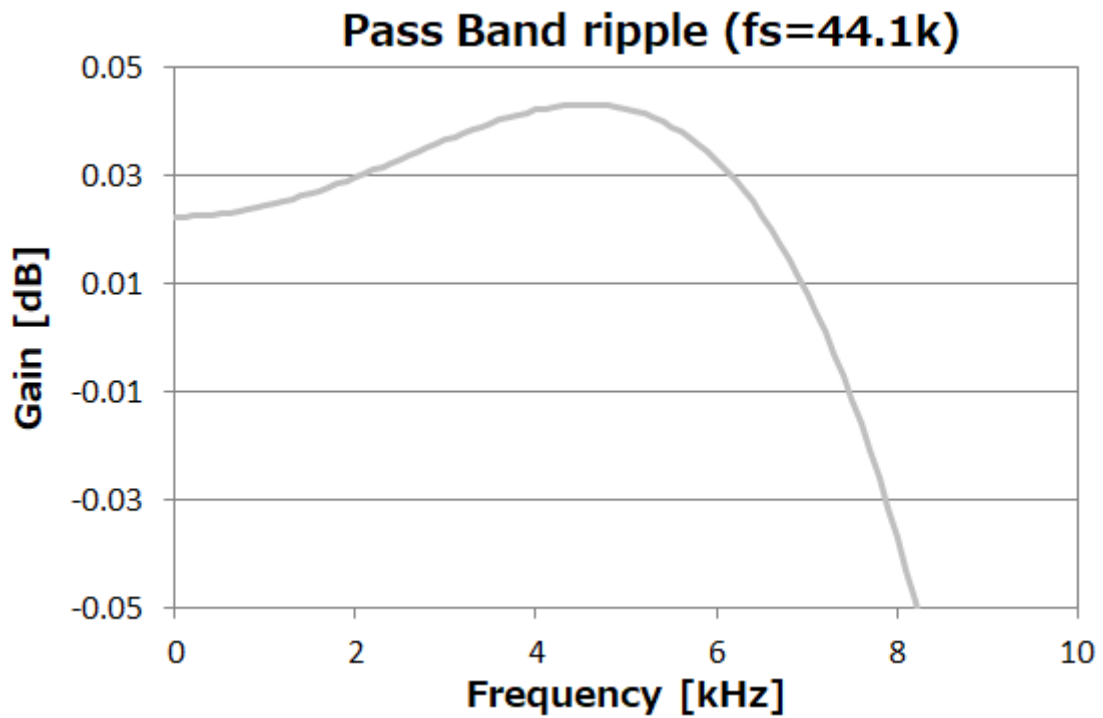

Figure 5. Slow Roll-off Filter Passband Ripple

8.2.3. Short Delay Sharp Roll-Off Filter Characteristics

(Ta = -40–105 °C: AVDD = 3.0–5.5 V, TVDD = 1.7–3.6 V: DEM[1:0] bits = “01”(OFF): ADPE bit = “0”, SYNCE bit = “1”, SLOW bit = “0”, SD bit = “1”, SSLOW bit = “0”)

• fs = 44.1 kHz (Normal Speed Mode)

| Parameter | | Symbol | Min. | Typ. | Max. | Unit |
|---------------------------------------|-----------|--------|------|------|---------|------|
| Digital Filter | | | | | | |
| Frequency Response (Note 23) | ±0.05 dB | - | 0 | - | 20.0 | kHz |
| | -3.0 dB | - | - | 21.5 | - | kHz |
| Pass band | (Note 28) | PB | 0 | - | 20.0 | kHz |
| Stop band | (Note 28) | SB | 24.1 | - | - | kHz |
| Pass band Ripple | (Note 25) | PR | - | - | ±0.0031 | dB |
| Stop band Attenuation | (Note 23) | SA | 80 | - | - | dB |
| Group Delay | (Note 26) | GD | - | 5.8 | - | 1/fs |
| Digital Filter + SCF (Note 23) | | | | | | |
| Frequency Response: 0–20.0 kHz | | | -0.2 | - | +0.1 | dB |

• fs = 96 kHz (Double Speed Mode)

| Parameter | | Symbol | Min. | Typ. | Max. | Unit |
|---------------------------------------|-----------|--------|------|------|---------|------|
| Digital Filter | | | | | | |
| Frequency Response (Note 23) | ±0.05 dB | - | 0 | - | 43.5 | kHz |
| | -3.0 dB | - | - | 46.8 | - | kHz |
| Pass band | (Note 28) | PB | 0 | - | 43.5 | kHz |
| Stop band | (Note 28) | SB | 52.5 | - | - | kHz |
| Pass band Ripple | (Note 25) | PR | - | - | ±0.0031 | dB |
| Stop band Attenuation | (Note 23) | SA | 80 | - | - | dB |
| Group Delay | (Note 26) | GD | - | 5.8 | - | 1/fs |
| Digital Filter + SCF (Note 23) | | | | | | |
| Frequency Response: 0–40.0 kHz | | | -0.6 | - | +0.1 | dB |

• fs = 192 kHz (Quad Speed Mode)

| Parameter | | Symbol | Min. | Typ. | Max. | Unit |
|---------------------------------------|-----------|--------|------|------|---------|------|
| Digital Filter | | | | | | |
| Frequency Response (Note 23) | ±0.05 dB | - | 0 | - | 87.0 | kHz |
| | -3.0 dB | - | - | 93.6 | - | kHz |
| Pass band | (Note 28) | PB | 0 | - | 87.0 | kHz |
| Stop band | (Note 28) | SB | 105 | - | - | kHz |
| Pass band Ripple | (Note 25) | PR | - | - | ±0.0031 | dB |
| Stop band Attenuation | (Note 23) | SA | 80 | - | - | dB |
| Group Delay | (Note 26) | GD | - | 5.8 | - | 1/fs |
| Digital Filter + SCF (Note 23) | | | | | | |
| Frequency Response: 0–80.0 kHz | | | -2.0 | - | +0.1 | dB |

Note 28. The passband and stopband frequencies scale with fs. For example, PB = 0.453 × fs (@ ±0.05 dB), SB = 0.547 × fs.

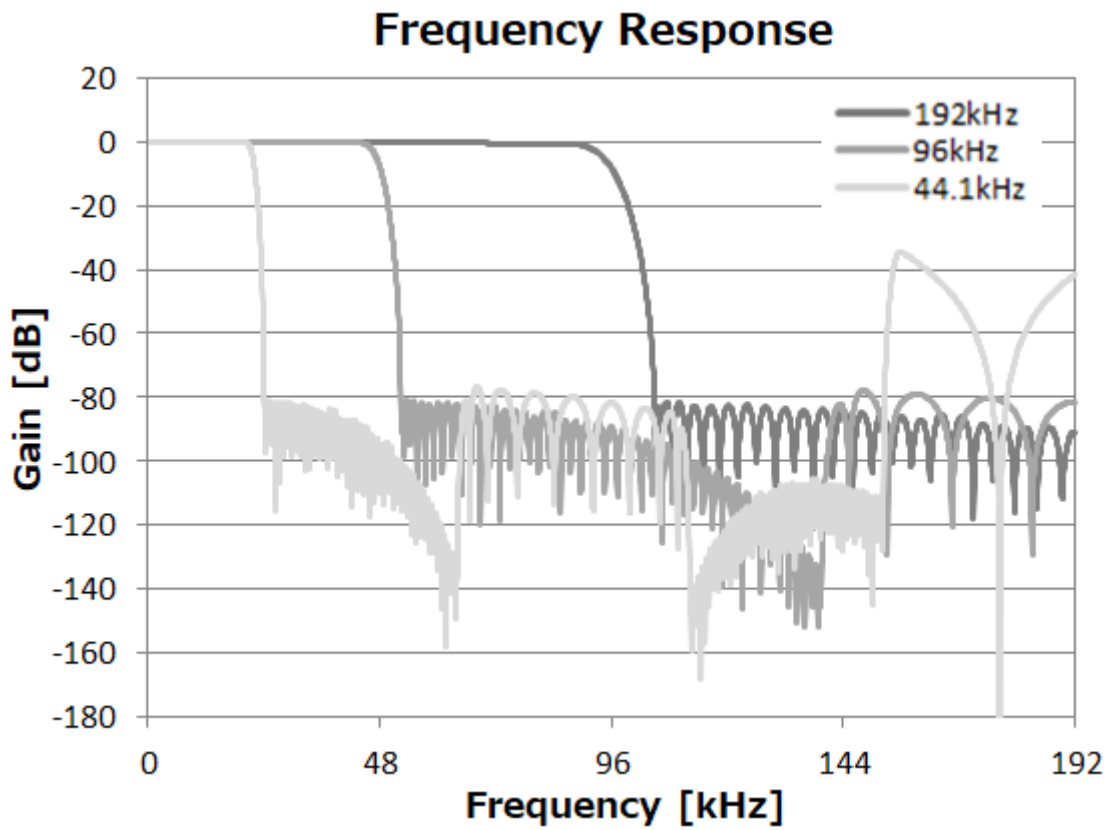

Figure 6. Short-delay Sharp Roll-off Filter Frequency Response

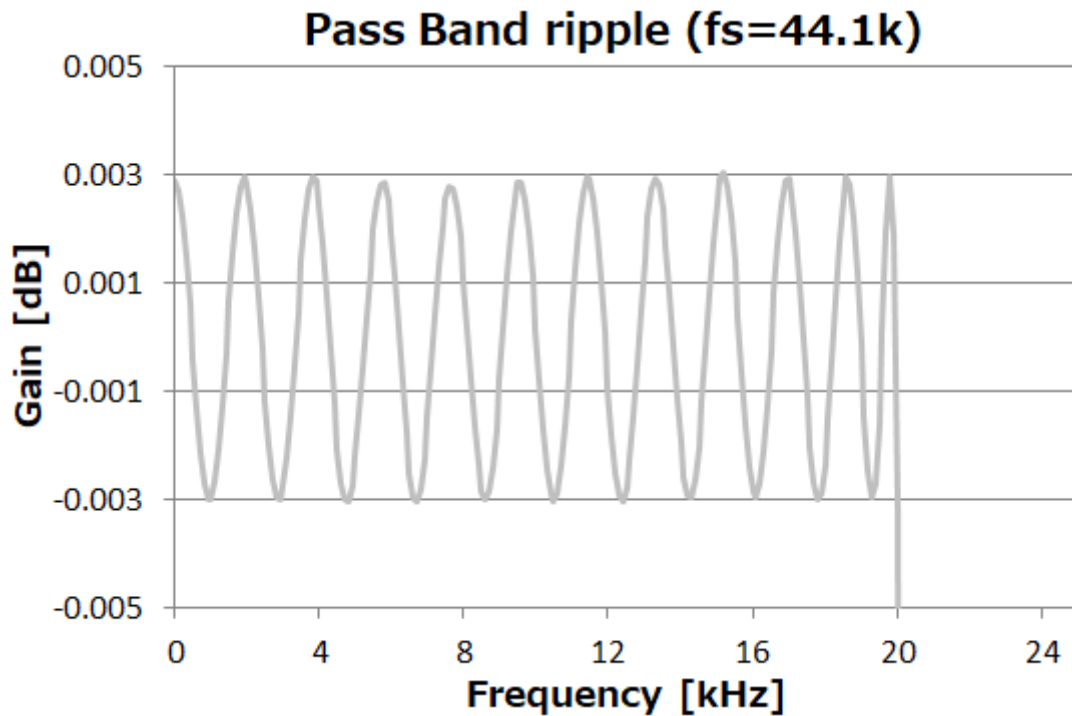

Figure 7. Short-delay Sharp Roll-off Filter Passband Ripple

8.2.4. Short Delay Slow Roll-Off Filter Characteristics

(Ta = -40–105 °C: AVDD = 3.0–5.5 V, TVDD = 1.7–3.6 V: DEM[1:0] bits = “01”(OFF): ADPE bit = “0”, SYNCE bit = “1”, SLOW bit = “1”, SD bit = “1”, SSLOW bit = “0”)

• fs = 44.1 kHz (Normal Speed Mode)

| Parameter | | Symbol | Min. | Typ. | Max. | Unit |
|---------------------------------------|-----------|--------|------|------|-------|------|
| Digital Filter | | | | | | |
| Frequency Response (Note 23) | ±0.05 dB | - | 0 | - | 11.1 | kHz |
| | -3.0 dB | - | - | 19.4 | - | kHz |
| Pass band | (Note 29) | PB | 0 | - | 11.1 | kHz |
| Stop band | (Note 29) | SB | 38.1 | - | - | kHz |
| Pass band Ripple | (Note 25) | PR | | - | ±0.05 | dB |
| Stop band Attenuation | (Note 23) | SA | 82 | - | - | dB |
| Group Delay | (Note 26) | GD | - | 4.8 | - | 1/fs |
| Digital Filter + SCF (Note 23) | | | | | | |
| Frequency Response: 0–20.0 kHz | | | -5.0 | - | +0.1 | dB |

• fs = 96 kHz (Double Speed Mode)

| Parameter | | Symbol | Min. | Typ. | Max. | Unit |
|---------------------------------------|-----------|--------|------|------|-------|------|
| Digital Filter | | | | | | |
| Frequency Response (Note 23) | ±0.05 dB | - | 0 | - | 24.2 | kHz |
| | -3.0 dB | - | - | 42.1 | - | kHz |
| Pass band | (Note 29) | PB | 0 | - | 24.2 | kHz |
| Stop band | (Note 29) | SB | 83 | - | - | kHz |
| Pass band Ripple | (Note 25) | PR | | - | ±0.05 | dB |
| Stop band Attenuation | (Note 23) | SA | 82 | - | - | dB |
| Group Delay | (Note 26) | GD | - | 4.8 | - | 1/fs |
| Digital Filter + SCF (Note 23) | | | | | | |
| Frequency Response: 0–40.0 kHz | | | -5.0 | - | +0.1 | dB |

• fs = 192 kHz (Quad Speed Mode)

| Parameter | | Symbol | Min. | Typ. | Max. | Unit |
|---------------------------------------|-----------|--------|-------|------|-------|------|
| Digital Filter | | | | | | |
| Frequency Response (Note 23) | ±0.05 dB | - | 0 | - | 48.4 | kHz |
| | -3.0 dB | - | - | 84.3 | - | kHz |
| Pass band | (Note 29) | PB | 0 | - | 48.4 | kHz |
| Stop band | (Note 29) | SB | 165.9 | - | - | kHz |
| Pass band Ripple | (Note 25) | PR | | - | ±0.05 | dB |
| Stop band Attenuation | (Note 23) | SA | 82 | - | - | dB |
| Group Delay | (Note 26) | GD | - | 4.8 | - | 1/fs |
| Digital Filter + SCF (Note 23) | | | | | | |
| Frequency Response: 0–80.0 kHz | | | -5.0 | - | +0.1 | dB |

Note 29. The passband and stopband frequencies scale with fs. For example, PB = 0.252 × fs (@±0.05 dB), SB = 0.864 × fs.

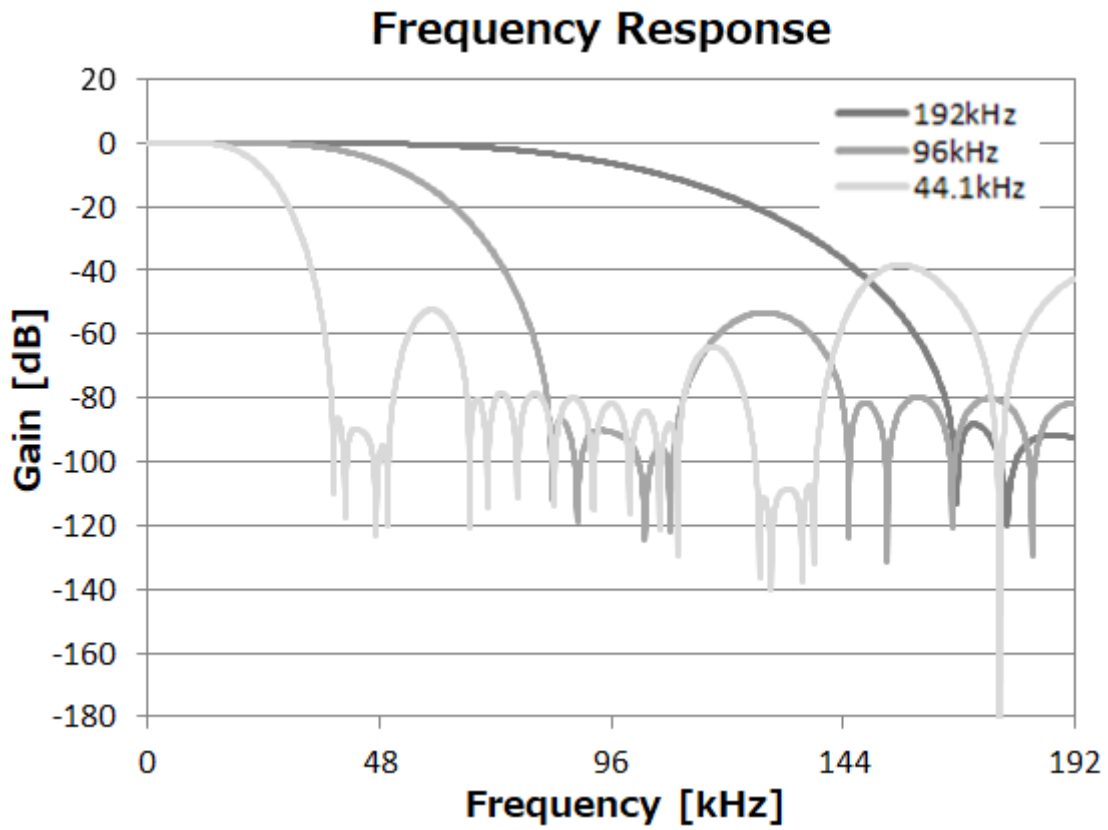

Figure 8. Short-delay Slow Roll-off Filter Frequency Response

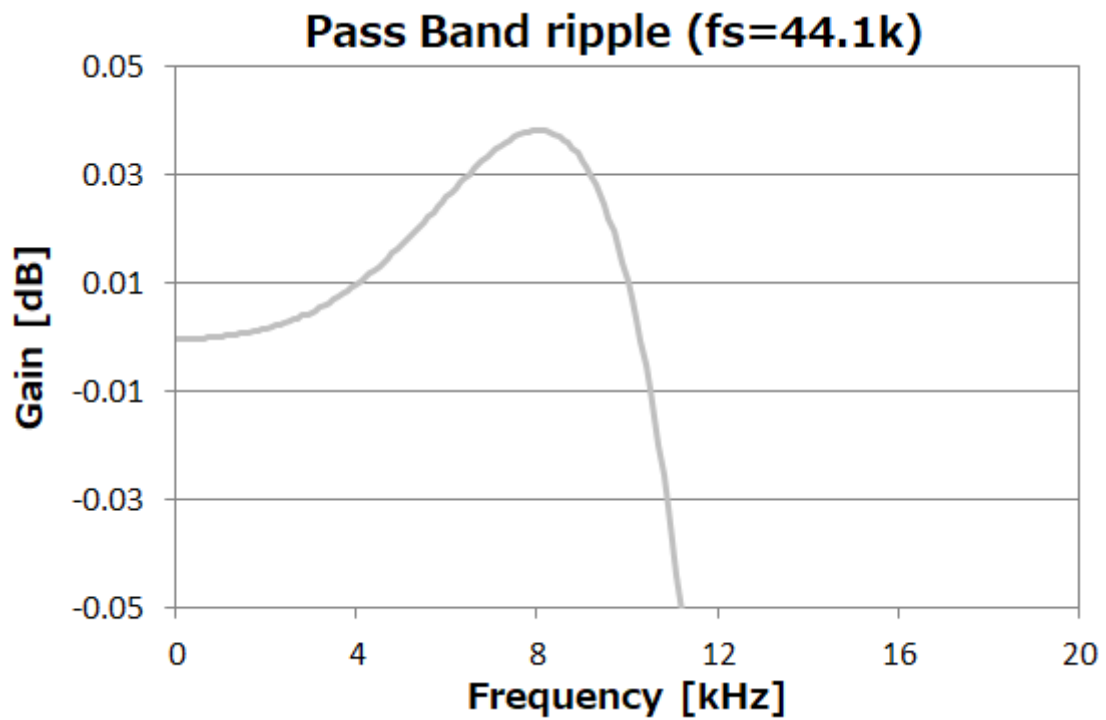

Figure 9. Short-delay Slow Roll-off Filter Passband Ripple

8.2.5. Low Dispersion Short Delay Filter Characteristics

(Ta = -40–105 °C: AVDD = 3.0–5.5 V, TVDD = 1.7–3.6 V: DEM[1:0] bits = “01”(OFF): ADPE bit = “0”, SYNCE bit = “1”, SLOW bit = “0”, SD bit = “1”, SSLOW bit = “1”)

• fs = 44.1 kHz (Normal Speed Mode)

| Parameter | | Symbol | Min. | Typ. | Max. | Unit |
|---------------------------------------|-----------|--------|------|-------|-------|------|
| Digital Filter | | | | | | |
| Frequency Response (Note 23) | ±0.1 dB | - | 0 | - | 19.2 | kHz |
| | -3.0 dB | - | - | 21.8 | - | kHz |
| Pass band | (Note 30) | PB | 0 | - | 19.2 | kHz |
| Stop band | (Note 30) | SB | 25.1 | - | - | kHz |
| Pass band Ripple | (Note 25) | PR | - | - | ±0.04 | dB |
| Stop band Attenuation | (Note 23) | SA | 62.0 | - | - | dB |
| Group Delay | (Note 26) | GD | - | 10.5 | - | 1/fs |
| Group Delay Distortion | | ΔGD | - | ±0.12 | - | 1/fs |
| Digital Filter + SCF (Note 23) | | | | | | |
| Frequency Response: 0–20.0 kHz | | | -0.2 | - | +0.1 | dB |

• fs = 96 kHz (Double Speed Mode)

| Parameter | | Symbol | Min. | Typ. | Max. | Unit |
|---------------------------------------|-----------|--------|------|-------|-------|------|
| Digital Filter | | | | | | |
| Frequency Response (Note 23) | ±0.1 dB | - | 0 | - | 41.8 | kHz |
| | -3.0 dB | - | - | 47.3 | - | kHz |
| Pass band | (Note 30) | PB | 0 | - | 41.8 | kHz |
| Stop band | (Note 30) | SB | 54.6 | - | - | kHz |
| Pass band Ripple | (Note 25) | PR | - | - | ±0.04 | dB |
| Stop band Attenuation | (Note 23) | SA | 62 | - | - | dB |
| Group Delay | (Note 26) | GD | - | 10.5 | - | 1/fs |
| Group Delay Distortion | | ΔGD | - | ±0.12 | - | 1/fs |
| Digital Filter + SCF (Note 23) | | | | | | |
| Frequency Response: 0–40.0 kHz | | | -0.6 | - | +0.1 | dB |

• fs = 192 kHz (Quad Speed Mode)

| Parameter | | Symbol | Min. | Typ. | Max. | Unit |
|---------------------------------------|-----------|--------|-------|-------|-------|------|
| Digital Filter | | | | | | |
| Frequency Response (Note 23) | ±0.1 dB | - | 0 | - | 83.6 | kHz |
| | -3.0 dB | - | - | 94.0 | - | kHz |
| Pass band | (Note 30) | PB | 0 | - | 83.6 | kHz |
| Stop band | (Note 30) | SB | 109.3 | - | - | kHz |
| Pass band Ripple | (Note 25) | PR | - | - | ±0.04 | dB |
| Stop band Attenuation | (Note 23) | SA | 62 | - | - | dB |
| Group Delay | (Note 26) | GD | - | 10.5 | - | 1/fs |
| Group Delay Distortion | | ΔGD | - | ±0.12 | - | 1/fs |
| Digital Filter + SCF (Note 23) | | | | | | |
| Frequency Response: 0–80.0 kHz | | | -2.0 | - | +0.1 | dB |

Note 30. The passband and stopband frequencies scale with fs. For example, PB = 0.435 × fs (@ ±0.1 dB), SB = 0.569 × fs.

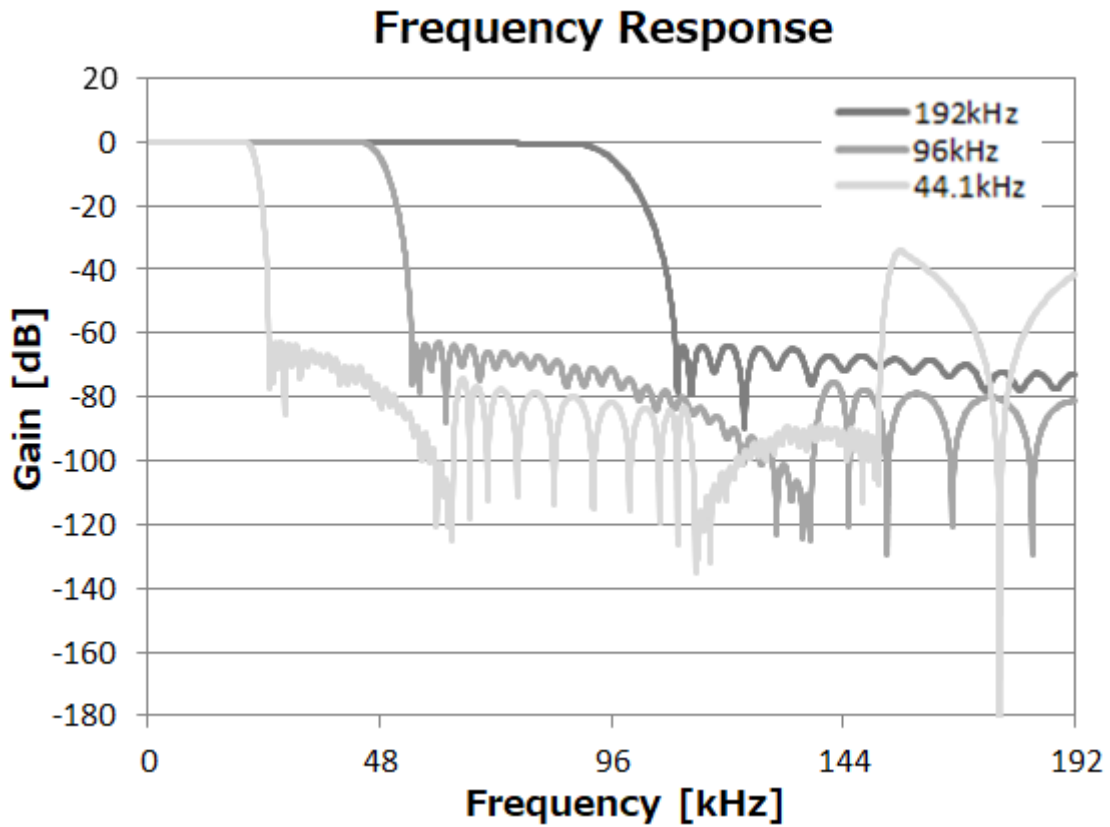

Figure 10. Low dispersion Short-delay Filter Frequency Response

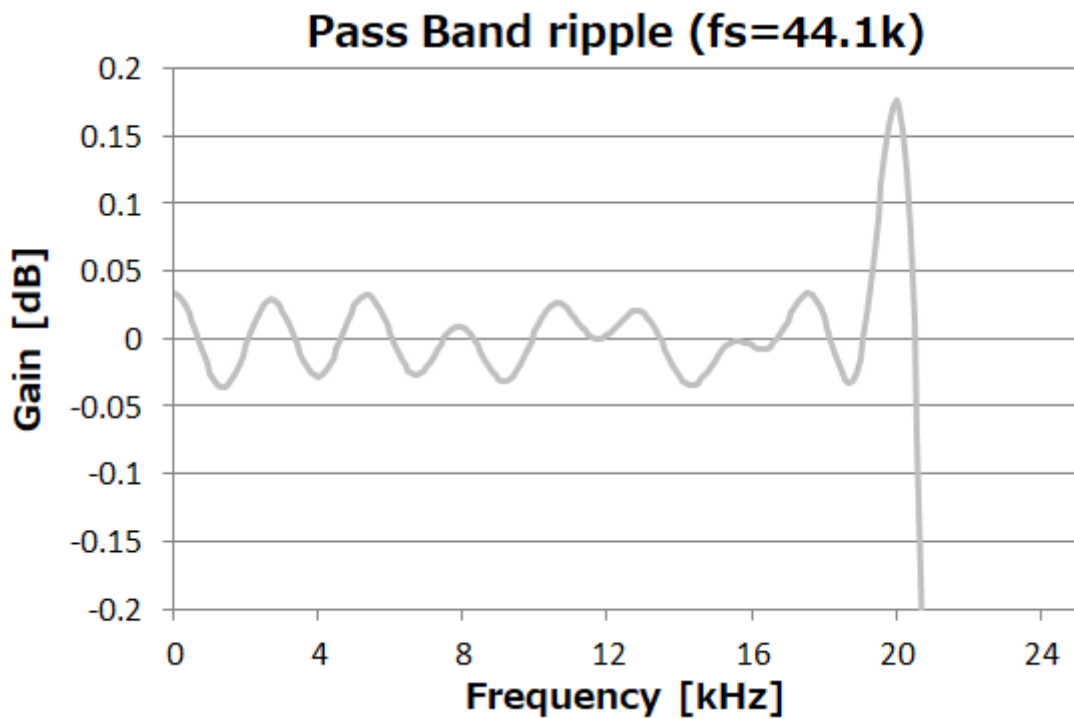

Figure 11. Low dispersion Short-delay Filter Passband Ripple

8.3. DAC Digital-Filter Characteristics (DSD mode, DoP mode)

(Ta = -40–105 °C: AVDD = 3.0–5.5 V, TVDD = 1.7–3.6 V: fs = 44.1 kHz)

8.3.1. DSDD bit = “0”, DSDF bit = “0”

| Parameter | | Min. | Typ. | Max. | Unit | |
|--|-------------|---------|-------|-------|------|----|
| DSD Filter Frequency Response (Note 32) | DSDSEL[1:0] | | | | | |
| | “00” | 20 kHz | - | -0.8 | - | dB |
| | | 50 kHz | - | -5.5 | - | |
| | | 100 kHz | - | -19.9 | - | |
| | “01” | 40 kHz | - | -0.8 | - | dB |
| | | 100 kHz | - | -5.5 | - | |
| | | 200 kHz | - | -19.9 | - | |
| | “10” | 80 kHz | - | -0.8 | - | dB |
| | | 200 kHz | - | -5.5 | - | |
| | | 400 kHz | - | -19.9 | - | |
| | “11” | 160 kHz | - | -0.8 | - | dB |
| | | 400 kHz | - | -5.5 | - | |
| 800 kHz | | - | -19.9 | - | | |

8.3.2. DSDD bit = “0”, DSDF bit = “1”

| Parameter | | Min. | Typ. | Max. | Unit | |
|--|-------------|---------|-------|-------|------|----|
| DSD Filter Frequency Response (Note 32) | DSDSEL[1:0] | | | | | |
| | “00” | 20 kHz | - | -0.2 | - | dB |
| | | 100 kHz | - | -6.3 | - | |
| | | 200 kHz | - | -23.7 | - | |
| | “01” | 40 kHz | - | -0.2 | - | dB |
| | | 200 kHz | - | -6.3 | - | |
| | | 400 kHz | - | -23.7 | - | |
| | “10” | 80 kHz | - | -0.2 | - | dB |
| | | 400 kHz | - | -6.3 | - | |
| | | 800 kHz | - | -23.7 | - | |
| | “11” | 160 kHz | - | -0.8 | - | dB |
| | | 800 kHz | - | -6.3 | - | |
| 1600 kHz | | - | -23.7 | - | | |

8.3.3. DSDD bit = “1”

| Parameter | | Min. | Typ. | Max. | Unit | |
|--|-------------|---------|------|-------|------|----|
| DSD Filter Frequency Response (Note 32) | DSDSEL[1:0] | | | | | |
| | “00” | 20 kHz | - | -0.2 | - | dB |
| | | 100 kHz | - | -6.3 | - | |
| | | 200 kHz | - | -23.7 | - | |
| | “01” | 40 kHz | - | -0.2 | - | dB |
| | | 200 kHz | - | -6.3 | - | |
| | | 400 kHz | - | -23.7 | - | |
| | “10” | 80 kHz | - | -0.2 | - | dB |
| | | 400 kHz | - | -6.3 | - | |
| | | 800 kHz | - | -23.7 | - | |
| | “11” | 160 kHz | - | -0.05 | - | dB |
| | | 500 kHz | - | -0.5 | - | |
| 1 MHz | | - | -1.9 | - | | |

Note 31. Do not input the signal which exceeds 25–75% duty range.

Note 32. Frequency response refers to the output level of 1 kHz.

8.4. DC Characteristics

(Ta = -40–105 °C: AVDD = 3.0–5.5 V, TVDD = 1.7–3.6 V; unless otherwise specified)

| Parameter | Symbol | Min. | Typ. | Max. | Unit |
|--|--------|----------|------|---------|------|
| TVDD = 1.7–3.0 V | | | | | |
| High-Level Input Voltage | VIH | 80%TVDD | - | - | V |
| Low-Level Input Voltage | VIL | - | - | 20%TVDD | V |
| TVDD = 3.0–3.6 V | | | | | |
| High-Level Input Voltage | VIH | 70%TVDD | - | - | V |
| Low-Level Input Voltage | VIL | - | - | 30%TVDD | V |
| High-Level Output Voltage | | | | | |
| DZF pin: Iout = -100 μA | VOH | TVDD-0.3 | - | - | V |
| Low-Level Output Voltage | | | | | |
| DZF pin: Iout = 100 μA | VOL | - | - | 0.3 | V |
| SDA pin, 2.0 V ≤ TVDD ≤ 3.6 V: Iout = 3 mA | VOL | - | - | 0.4 | V |
| SDA pin, 1.7 V ≤ TVDD ≤ 2.0 V: Iout = 3 mA | VOL | - | - | 20%TVDD | V |
| Input Leakage Current (Note 33) | Iin | - | - | ±10 | μA |

Note 33. SMUTE pin has internal pull-down resistors. The resistance is 100 kΩ (Typ.). Therefore, the SMUTE pin is not included in this value.

8.5. Switching Characteristics

(Ta = -40–105 °C: AVDD = 3.0–5.5V, TVDD = 1.7–3.6 V)

| Parameter | Symbol | Min. | Typ. | Max. | Unit |
|--|--------|---------|------|---------|------|
| Master Clock Timing (Note 34) | | | | | |
| Frequency | fCLK | 1.8432 | - | 49.6640 | MHz |
| Duty Cycle | dCLK | 40 | - | 60 | % |
| Minimum Pulse Width High | tCLKH | 9.05 | - | - | ns |
| Minimum Pulse Width Low | tCLKL | 9.05 | - | - | ns |
| LRCK Clock Timing | | | | | |
| Normal Mode (TDM[1:0] = "00") , | | | | | |
| Normal Speed Mode | fsn | 7.2 | - | 54 | kHz |
| Double Speed Mode | fsd | 54 | - | 108 | kHz |
| Quad Speed Mode, | fsq | 108 | - | 216 | kHz |
| Oct Speed Mode | fso | 216 | - | 388 | kHz |
| Hex Speed Mode | fsh | 388 | - | 776 | kHz |
| Duty Cycle | Duty | 45 | - | 55 | % |
| TDM128 Mode (TDM[1:0] = "01") | | | | | |
| Normal Speed Mode | fsn | 7.2 | - | 54 | kHz |
| Double Speed Mode | fsd | 54 | - | 108 | kHz |
| Quad Speed Mode | fsq | 108 | - | 216 | kHz |
| High time | tLRH | 1/128fs | - | - | ns |
| Low time | tLRL | 1/128fs | - | - | ns |
| TDM256 Mode (TDM[1:0] = "10") | | | | | |
| Normal Speed Mode High time | fsn | 7.2 | - | 54 | kHz |
| Double Speed Mode | fsd | 54 | - | 108 | kHz |
| High time | tLRH | 1/256fs | - | - | ns |
| Low time | tLRL | 1/256fs | - | - | ns |
| TDM512 Mode (TDM[1:0] = "11") | | | | | |
| Normal Speed Mode | fsn | 7.2 | - | 54 | kHz |
| High time | tLRH | 1/512fs | - | - | ns |
| Low time | tLRL | 1/512fs | - | - | ns |

Note 34. The MCLK frequency must be changed while the AK4462 is in power down state or reset state by setting the PDN pin = "L" or RSTN bit = "0".

| Parameter | Symbol | Min. | Typ. | Max. | Unit |
|--------------------------------------|--------|----------|------|------|------|
| PCM Audio Interface Timing | | | | | |
| Normal Mode (TDM[1:0] = "00") | | | | | |
| BICK Period | | | | | |
| Normal Speed Mode | tBCK | 1/256fsn | - | - | ns |
| Double Speed Mode | tBCK | 1/128fsd | - | - | ns |
| Quad Speed Mode | tBCK | 1/64fsq | - | - | ns |
| Oct Speed Mode | tBCK | 1/64fso | - | - | ns |
| Hex Speed Mode | tBCK | 1/64fsh | - | - | ns |
| BICK Pulse Width Low | tBCKL | 9 | - | - | ns |
| BICK Pulse Width High | tBCKH | 9 | - | - | ns |
| BICK "↑" to LRCK Edge (Note 35) | tBLR | 5 | - | - | ns |
| LRCK Edge to BICK "↑" (Note 35) | tLRB | 5 | - | - | ns |
| SDTI Hold Time | tSDH | 5 | - | - | ns |
| SDTI Setup Time | tSDS | 5 | - | - | ns |
| TDM128 Mode (TDM[1:0] = "01") | | | | | |
| BICK Period | | | | | |
| Normal Speed Mode | tBCK | 1/128fsn | - | - | ns |
| Double Speed Mode | tBCK | 1/128fsd | - | - | ns |
| Quad Speed Mode | tBCK | 1/128fsq | - | - | ns |
| BICK Pulse Width Low | tBCKL | 14 | - | - | ns |
| BICK Pulse Width High | tBCKH | 14 | - | - | ns |
| BICK "↑" to LRCK Edge (Note 35) | tBLR | 14 | - | - | ns |
| LRCK Edge to BICK "↑" (Note 35) | tLRB | 14 | - | - | ns |
| SDTI Hold Time | tSDH | 5 | - | - | ns |
| SDTI Setup Time | tSDS | 5 | - | - | ns |
| TDM256 Mode (TDM[1:0] = "10") | | | | | |
| BICK Period | | | | | |
| Normal Speed Mode | tBCK | 1/256fsn | - | - | ns |
| Double Speed Mode | tBCK | 1/256fsd | - | - | ns |
| BICK Pulse Width Low | tBCKL | 14 | - | - | ns |
| BICK Pulse Width High | tBCKH | 14 | - | - | ns |
| BICK "↑" to LRCK Edge (Note 35) | tBLR | 14 | - | - | ns |
| LRCK Edge to BICK "↑" (Note 35) | tLRB | 14 | - | - | ns |
| SDTI Hold Time | tSDH | 5 | - | - | ns |
| SDTI Setup Time | tSDS | 5 | - | - | ns |
| TDM512 Mode (TDM[1:0] = "11") | | | | | |
| BICK Period | | | | | |
| Normal Speed Mode | tBCK | 1/512fsn | - | - | ns |
| BICK Pulse Width Low | tBCKL | 14 | - | - | ns |
| BICK Pulse Width High | tBCKH | 14 | - | - | ns |
| BICK "↑" to LRCK Edge (Note 35) | tBLR | 14 | - | - | ns |
| LRCK Edge to BICK "↑" (Note 35) | tLRB | 14 | - | - | ns |
| SDTI Hold Time | tSDH | 5 | - | - | ns |
| SDTI Setup Time | tSDS | 5 | - | - | ns |

Note 35. It is defined so that LRCK edges do not occur at the same timing of a rising edge of BICK.

| Parameter | Symbol | Min. | Typ. | Max. | Unit |
|--|--------|------|---------|------|------|
| DSD Audio Interface Timing | | | | | |
| Sampling Frequency | fs | 30 | - | 48 | kHz |
| (DSD64 Mode, DSDSEL[1:0]bits="00") | | | | | |
| DCLK Period | tDCK | - | 1/64fs | - | ns |
| DCLK Pulse Width Low | tDCKL | 144 | - | - | ns |
| DCLK Pulse Width High | tDCKH | 144 | - | - | ns |
| DCLK Edge to DSDL/R (Note 36) | tDDD | -20 | - | 20 | ns |
| (DSD128 Mode, DSDSEL[1:0]bits="01") | | | | | |
| DCLK Period | tDCK | - | 1/128fs | - | ns |
| DCLK Pulse Width Low | tDCKL | 72 | - | - | ns |
| DCLK Pulse Width High | tDCKH | 72 | - | - | ns |
| DCLK Edge to DSDL/R (Note 36) | tDDD | -10 | - | 10 | ns |
| (DSD256 Mode, DSDSEL[1:0]bits="10") | | | | | |
| DCLK Period | tDCK | - | 1/256fs | - | ns |
| DCLK Pulse Width Low | tDCKL | 36 | - | - | ns |
| DCLK Pulse Width High | tDCKH | 36 | - | - | ns |
| DCLK Edge to DSDL/R (Note 36) | tDDD | -5 | - | 5 | ns |
| (DSD512 Mode, DSDSEL[1:0]bits="11") | | | | | |
| DCLK Period | tDCK | - | 1/512fs | - | ns |
| DCLK Pulse Width Low | tDCKL | 18 | - | - | ns |
| DCLK Pulse Width High | tDCKH | 18 | - | - | ns |
| DSDL/R Setup Time | tDDS | 5 | - | - | ns |
| DSDL/R Hold Time | tDDH | 5 | - | - | ns |

Note 36. DSD data transmitting device must meet this time. "tDDD" is defined from DCLK "↓" until DSDL/R edge when DCKB bit = "0" (default), "tDDD" is defined from DCLK "↑" until DSDL/R edge when DCKB bit = "1". If the audio data format is in phase modulation mode, "tDDD" is defined from DCLK edge "↓" or "↑" until DSDL/R edge regardless of DCKB bit setting.

| Parameter | Symbol | Min. | Typ. | Max. | Unit |
|-----------------------------------|--------|------|------------|------|------|
| DoP Audio Interface Timing | | | | | |
| Sampling Frequency | fs | 30 | - | 48 | kHz |
| LRCK Clock Timing | | | | | |
| DoP64 Mode | fLR | 108 | - | 216 | kHz |
| DoP128 Mode | fLR | 216 | - | 388 | kHz |
| DoP256 Mode | fLR | 388 | - | 776 | kHz |
| Duty Cycle | Duty | 45 | - | 55 | % |
| BICK Period | | | | | |
| DoP64 Mode (Note 37) | | | | | |
| (DIF[2:0]bits="01x", "100") | tBCK | - | 1/(48*fLR) | - | ns |
| (DIF[2:0]bits="101", "11x") | tBCK | - | 1/(64*fLR) | - | ns |
| DoP128 Mode (Note 37) | | | | | |
| (DIF[2:0]bits="01x", "100") | tBCK | - | 1/(48*fLR) | - | ns |
| (DIF[2:0]bits="101", "11x") | tBCK | - | 1/(64*fLR) | - | ns |
| DoP256 Mode (Note 37) | | | | | |
| (DIF[2:0]bits="01x", "100") | tBCK | - | 1/(48*fLR) | - | ns |
| (DIF[2:0]bits="101", "11x") | tBCK | - | 1/(64*fLR) | - | ns |
| (x:do not care) | | | | | |
| BICK Pulse Width Low | tBCKL | 9 | - | - | ns |
| BICK Pulse Width High | tBCKH | 9 | - | - | ns |
| BICK "↑" to LRCK Edge (Note 35) | tBLR | 5 | - | - | ns |
| LRCK Edge to BICK "↑" (Note 35) | tLRB | 5 | - | - | ns |
| SDTI Hold Time | tSDH | 5 | - | - | ns |
| SDTI Setup Time | tSDS | 5 | - | - | ns |

Note 37. In DoP mode, required BICK period is different from DSD mode. Refer to "[9.4.3.1 DoP mode Input Data Format](#)" for detail information.

| Parameter | Symbol | Min. | Typ. | Max. | Unit |
|--|---------|------|------|------|------|
| Control Interface Timing (3-wire Serial Control Mode): | | | | | |
| CCLK Period | tCCK | 200 | - | - | ns |
| CCLK Pulse Width Low | tCCKL | 80 | - | - | ns |
| Pulse Width High | tCCKH | 80 | - | - | ns |
| CDTI Setup Time | tCDS | 40 | - | - | ns |
| CDTI Hold Time | tCDH | 40 | - | - | ns |
| CSN "H" Time | tCSW | 150 | - | - | ns |
| CSN "↓" to CCLK "↑" | tCSS | 50 | - | - | ns |
| CCLK "↑" to CSN "↑" | tCSH | 50 | - | - | ns |
| Control Interface Timing (I²C-Bus Control Mode): | | | | | |
| SCL Clock Frequency | fSCL | - | - | 400 | kHz |
| Bus Free Time Between Transmissions | tBUF | 1.3 | - | - | μs |
| Start Condition Hold Time (prior to first clock pulse) | tHD:STA | 0.6 | - | - | μs |
| Clock Low Time | tLOW | 1.3 | - | - | μs |
| Clock High Time | tHIGH | 0.6 | - | - | μs |
| Setup Time for Repeated Start Condition | tSU:STA | 0.6 | - | - | μs |
| SDA Hold Time from SCL Falling (Note 38) | tHD:DAT | 0 | - | - | μs |
| SDA Setup Time from SCL Rising | tSU:DAT | 0.1 | - | - | μs |
| Rise Time of Both SDA and SCL Lines | tR | - | - | 0.3 | μs |
| Fall Time of Both SDA and SCL Lines | tF | - | - | 0.3 | μs |
| Setup Time for Stop Condition | tSU:STO | 0.6 | - | - | μs |
| Pulse Width of Spike Noise Suppressed by Input Filter | tSP | 0 | - | 50 | ns |
| Capacitive load on bus | Cb | - | - | 400 | pF |
| Power-down & Reset Timing | | | | | |
| PDN Accept Pulse Width | tAPD | 150 | - | - | ns |
| PDN Reject Pulse Width | tRPD | - | - | 30 | ns |

Note 38. Data must be held for sufficient time to bridge the 300 ns transition time of SCL.

Note 39. I²C-Bus is a trademark of NXP B.V.

8.6. Timing Diagram

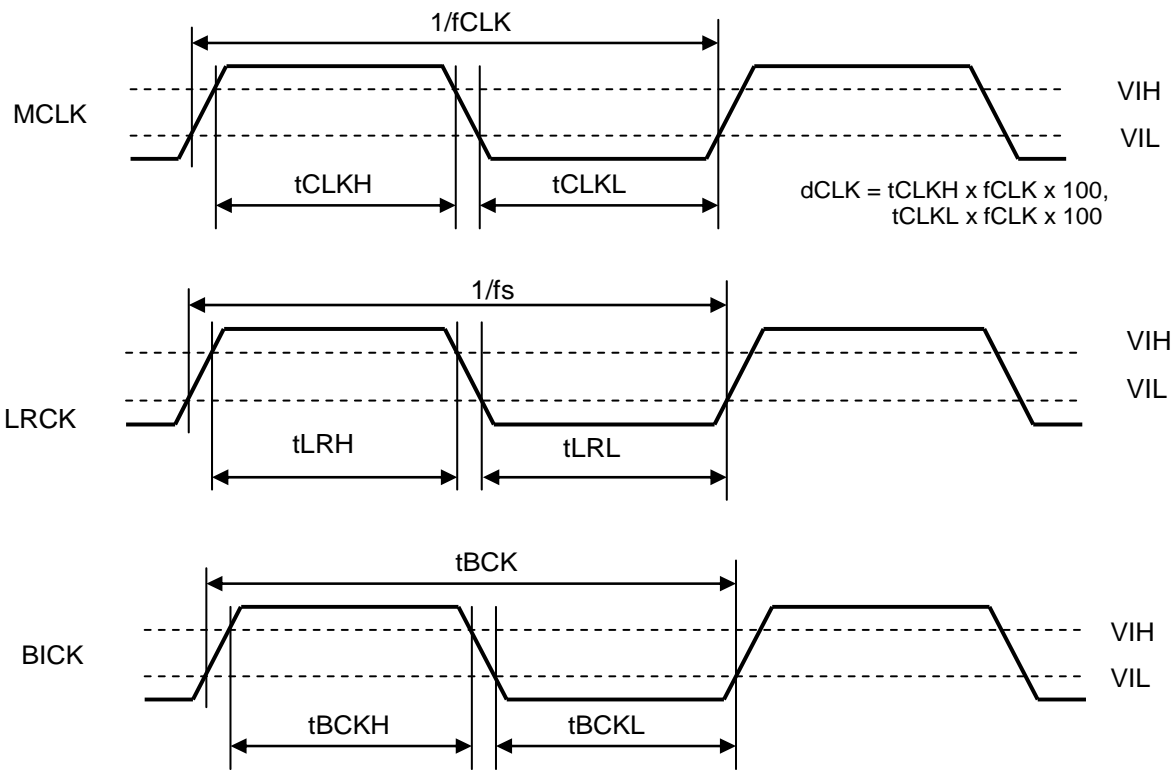

Figure 12. Clock Timing

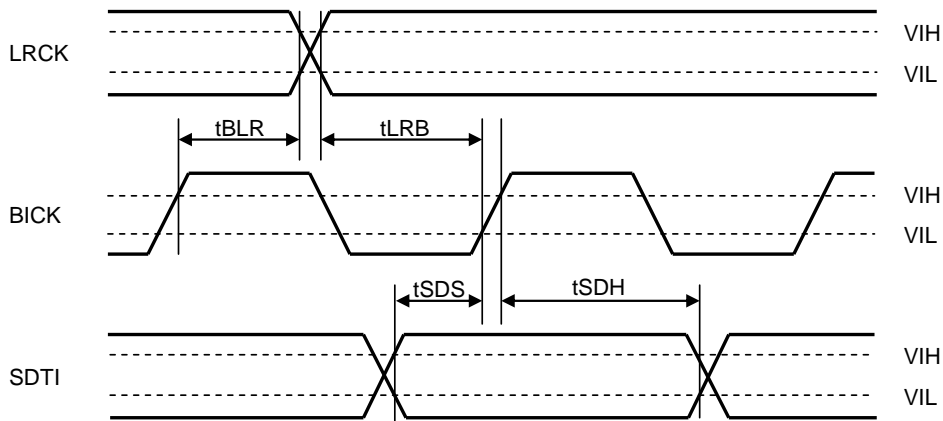
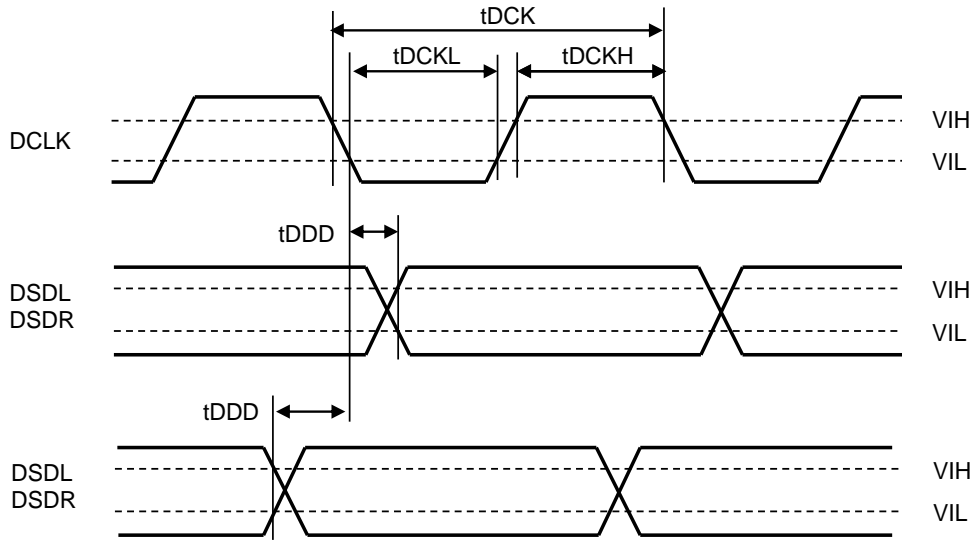
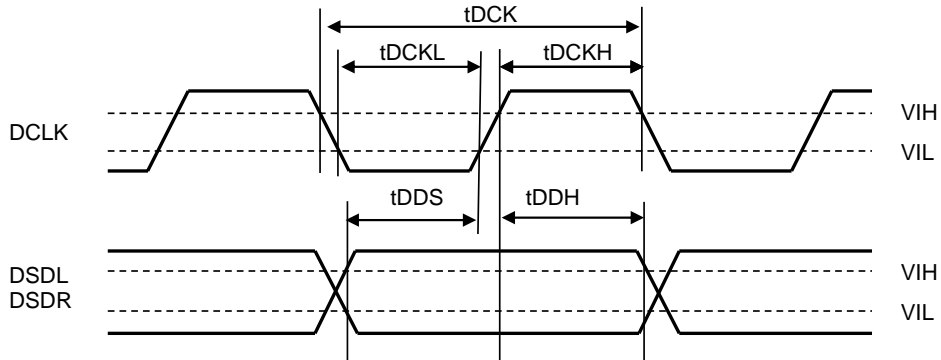

Figure 13. Audio Interface Timing (PCM mode, DoP mode)



DSD Audio Interface Timing (DSD64/128/256 Mode)



DSD Audio Interface Timing (DSD512 Mode)

Figure 14. Audio Interface Timing (DSD mode, DCKB bit = "0")

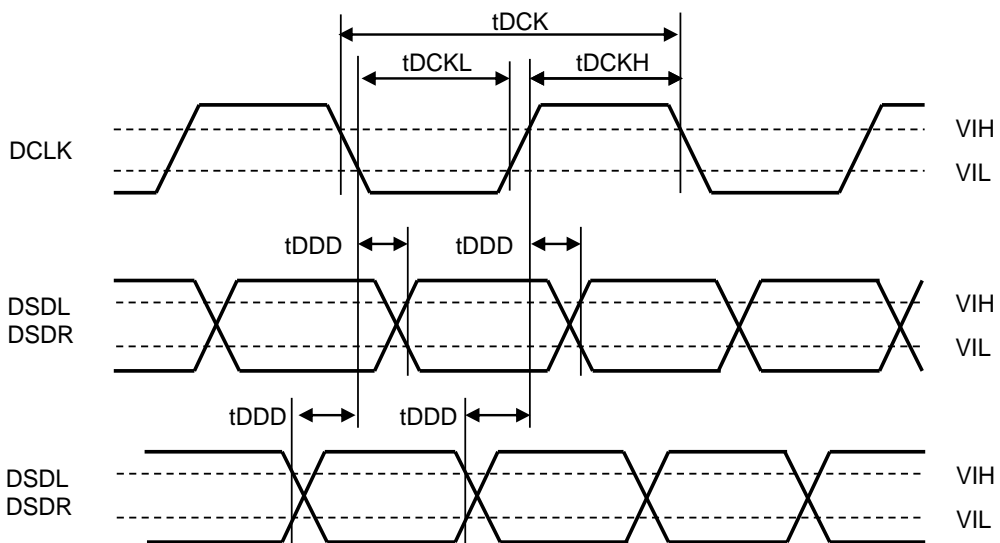

Figure 15. Audio Interface Timing (DSD mode, Phase Modulation Format, DCKB bit = "0")

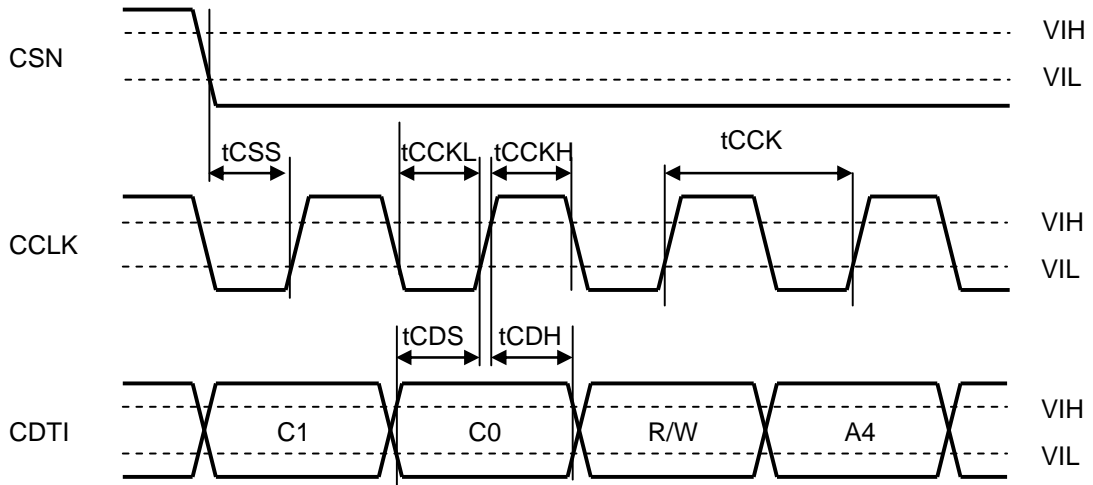

Figure 16. WRITE Command Input Timing (3-wire Serial Control Mode)

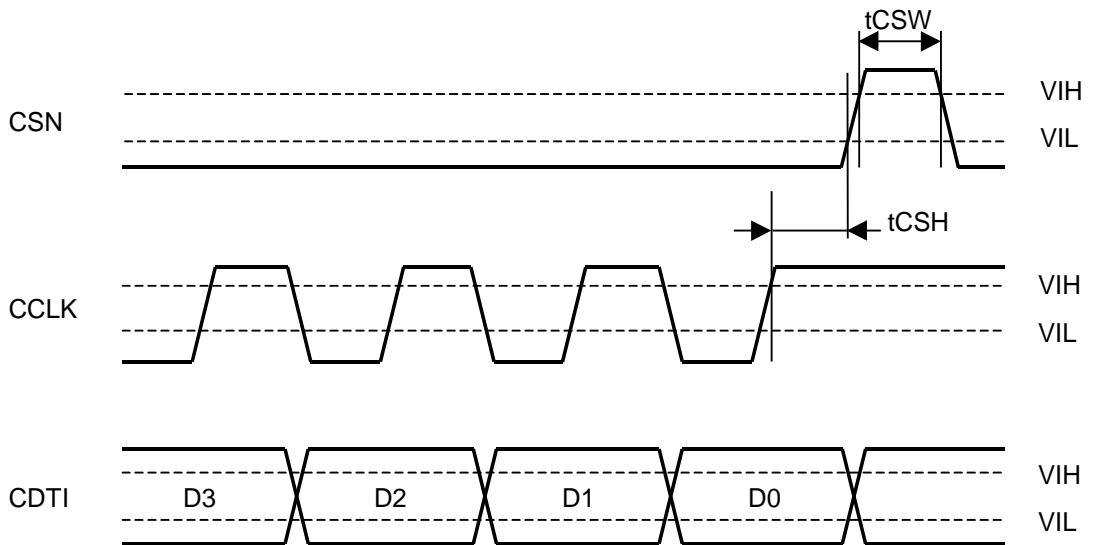

Figure 17. WRITE Data Input Timing (3-wire Serial Control Mode)

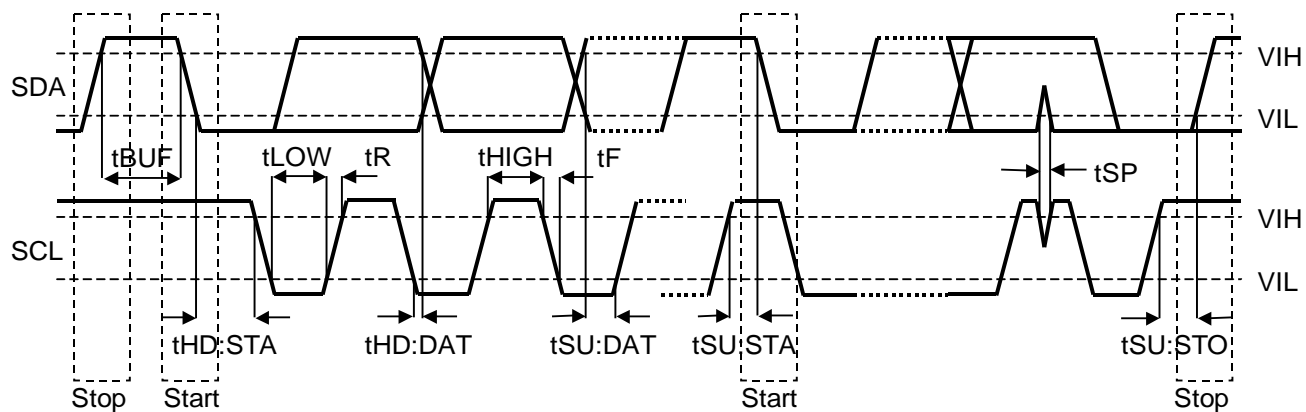

Figure 18. I²C-Bus Control Mode Timing

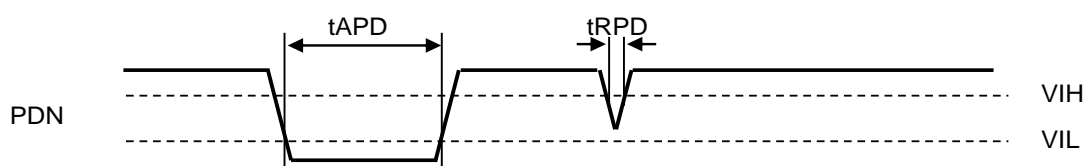

Figure 19. Power Down & Reset Timing

9. Functional Descriptions

9.1. Control Mode

Each function of the AK4462 is controlled by pins (Pin Control Mode) or registers (Register Control Mode) (Table 1). Select the control mode by setting the PS pin and the I2C pin. The AK4462 must be powered down by the PDN pin when changing the PS and the I2C pin settings. There is a possibility of malfunction if the device is not powered down when changing the control mode since the previous setting is not reinitialized. Register settings are invalid in Pin Control Mode, and pin settings are invalid in Register Control Mode.

Table 2 shows available functions of each control mode.

Table 1. Pin/Register Control Mode Select (x: do not care)

| I2C pin | PS pin | Control Mode |
|---------|--------|--|
| L | x | 3-wire serial Register Control Mode |
| H | L | I ² C Bus Register Control Mode |
| H | H | Pin Control Mode |

Table 2. Function List @Pin/Register Control Mode
(Y: Available, N/A : Not available)

| Function | Pin Control Mode | Register Control Mode |
|---|------------------|-----------------------|
| DSD Mode Select | N/A | Y |
| System Clock Setting Select | Y | Y |
| Audio Format Select | Y | Y |
| TDM Mode | Y | Y |
| Digital Filter Select | N/A | Y |
| De-emphasis Filter Select | N/A | Y |
| Digital Attenuator | N/A | Y |
| Zero Detection | N/A | Y |
| Monaural Mode | N/A | Y |
| Output signal select (Monaural, Channel select) | N/A | Y |
| Output signal polarity select (Invert) | N/A | Y |
| DSD FullScale Detect | N/A | Y |
| Soft Mute | Y | Y |
| Register Reset | N/A | Y |
| Clock Synchronization Function disable (default: enable) | N/A | Y |
| Automatic Mode Switching (PCM/DSD, PCM/DoP) | N/A | Y |
| Register Control | N/A | Y |
| DoP Mode Select | N/A | Y |

9.2. D/A Conversion Mode

The AK4462 is able to convert PCM data, DSD data, and DoP data to an analog signal. The AK4462 only supports PCM data (PCM mode) in pin control mode.

Table 3 shows available functions in PCM/DSD/DoP mode.

Table 3 Function List of PCM/DSD/DoP mode @Register Control Mode
(Y: Available, N/A : Not available)

| Function | Default | Addr | Bit | PCM | DSD | | DoP | |
|---|---|---------------|------------------------|----------------|--------|---------------|--------|---------------|
| | | | | | Normal | Volume Bypass | Normal | Volume Bypass |
| PCM/DSD Mode Select | PCM mode | 02H | DP | Y | Y | Y | N/A | N/A |
| PCM/DoP Mode Select | PCM mode | 16H | DOP | Y | N/A | N/A | Y | Y |
| System clock setting @PCM, DoP Mode | 512fs | 00H | ACKS | Y | N/A | N/A | Y | Y |
| System clock setting @DSD mode | 512fs | 02H | DCKS | N/A | Y | Y | Y | Y |
| Digital Filter select @DSD mode | 39kHz filter | 09H | DSDf | N/A | Y | N/A | Y | N/A |
| Digital Filter select @PCM mode | Short-delay sharp roll-off filter | 01,02, 05H | SD SLOW SSLOW | Y (Note 40) | N/A | N/A | N/A | N/A |
| De-emphasis Response | OFF | 01H | DEM[1:0] | Y | N/A | N/A | N/A | N/A |
| Path select @ DSD mode | Normal Path | 06H | DSDD | N/A | Y | Y | Y | Y |
| Audio Data Interface Format @ PCM mode, DoP mode | 32bit MSB | 00H | DIF[2:0] | Y | N/A | N/A | Y | Y |
| TDM Interface Format | Normal Mode | 0AH | TDM[1:0] | Y | N/A | N/A | N/A | N/A |
| Attenuation Level | 0dB | 03-04H | ATTL[7:0] ATTR[7:0] | Y | Y | N/A | Y | N/A |
| Data Zero Detect Enable | Disable | 08H | L, R | Y | Y | N/A | Y | N/A |
| Monaural/Stereo Mode select | Stereo | 02H | MONO | Y | Y | Y | Y | Y |
| Data Invert Mode select | OFF | 05H | INVL,INVR | Y | Y | Y | Y | Y |
| The data selection of L channel and R channel | R channel | 02H | SELLR | Y | Y | Y | Y | Y |
| DSD Mute Function @ Fullscale Detected | Disable | 06H | DDM | N/A | Y | Y | Y | Y |
| Soft Mute Enable | Normal Operation | 01H | SMUTE | Y | Y | Y | Y | Y |
| RSTN | Reset | 00H | RSTN | Y | Y | Y | Y | Y |
| Clock Synchronization Function | Enable | 07H | SYNCE | Y | N/A | N/A | Y | Y |
| Automatic Mode Switching (PCM/DSD Mode) | Disable | 15H | ADPE | Y | Y | Y | N/A | N/A |
| Automatic Mode Switching (PCM/DoP Mode) | Disable | 16H | ADOPE | N/A | N/A | N/A | Y | Y |

Note 40. The digital filter is fixed to super slow roll-off filter in Oct Speed Mode and Hex Speed Mode.

For mode switching among PCM/DSD/DoP modes, manual or automatic switching can be selected. These modes are controlled by ADOPE bit, DOP bit, ADPE bit and DP bit.

When ADOPE bit = "0", PCM and DoP modes can be switched manually by DOP bit. When ADOPE bit = "0", DOP bit = "0" and ADPE bit = "0", PCM and DSD modes can be switched manually by DP bit. Manual mode switching by DOP bit or DP bit must be executed while RSTN bit = "0". Do not change RSTN bit setting for $4/f_s$ after changing the data mode. It takes $2/f_s \sim 3/f_s$ for data mode transition.

When ADOPE bit = "0", DOP bit = "0" and ADPE bit = "1", automatic switching of PCM and DSD modes is enabled. In this case, DP bit setting is invalid. The AK4462 monitors input signal of the pin No. 4 and detects PCM or DSD data to switch data mode automatically. Refer to ["9.10 PCM/DSD Automatic Mode Switching Function"](#) for details about automatic mode switching.

When ADOPE bit = "1", automatic switching of PCM and DoP modes is enabled. In this case, DOP bit, ADPE bit and DP bit settings are invalid. The AK4462 monitors input signal of the pin No. 5 and detects PCM or DoP data to switch data mode automatically. Refer to ["9.11 PCM/DoP Automatic Mode Switching Function"](#) for details about automatic mode switching.

Table 4. PCM/DSD/DoP Mode Control @Register Control Mode (x: do not care)

| ADOPE bit | DOP bit | ADPE bit | DP bit | D/A Conv. Mode | Pin Assign | | |
|-----------|---------|----------|-------------------|-------------------|------------|------------|--------|
| | | | | | #3 pin | #4 pin | #5 pin |
| 0 | 0 | 0 | 0 | PCM | BICK | LRCK | SDTI |
| | | | 1 | DSD | DCLK | DSDL | DSDR |
| | 1 | x | Auto (PCM or DSD) | BICK /DCLK | LRCK /DSDL | SDTI /DSDR | |
| | 1 | x | DoP | BICK | LRCK | SDTI | |
| 1 | x | x | x | Auto (PCM or DoP) | BICK | LRCK | SDTI |

9.2.1. D/A Conversion Mode Switching Timing (PCM/DSD Manual Setting)

Figure 20 and Figure 21 show switching timing of PCM and DSD modes in manual mode (ADPE bit = "0"). To prevent noise caused by excessive input, DSD signal should be input $4/f_s$ after setting RSTN bit = "0" until the device is completely reset internally when the conversion mode is changed to DSD mode from PCM mode. DSD signal should be stopped $4/f_s$ after setting RSTN bit = "0" until the device is completely reset internally when the conversion mode is changed to PCM from DSD mode.

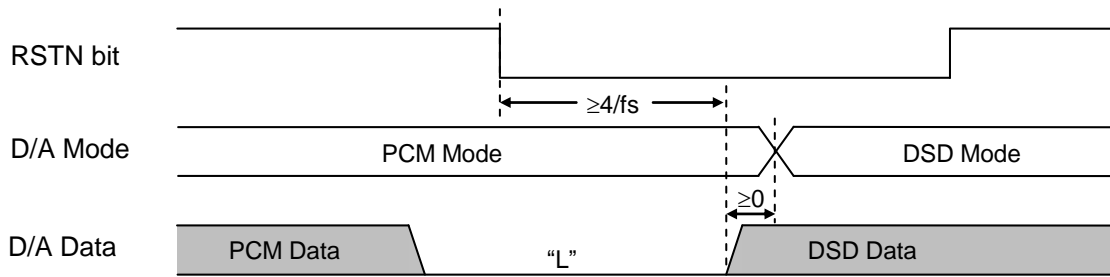

Figure 20. D/A Mode Switching Timing (from PCM to DSD)

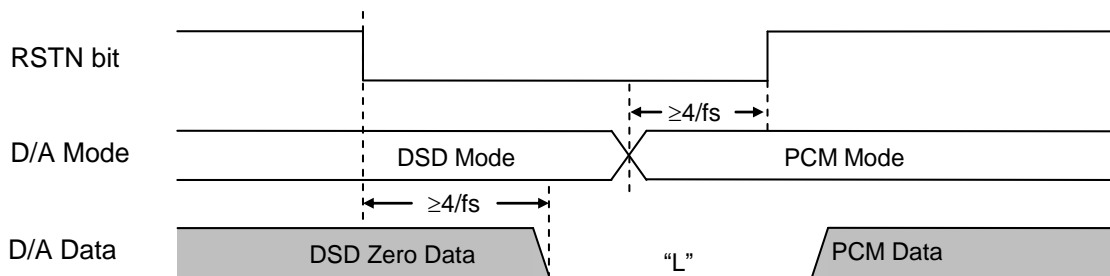

Figure 21. D/A Mode Switching Timing (from DSD to PCM)

9.2.2. D/A Conversion Mode Switching Timing (PCM/DoP Manual Setting)

Figure 22 and Figure 23 show switching timing of PCM and DoP modes in manual mode (ADPE bit = "0"). To prevent noise caused by excessive input, DoP signal should be input $4/f_s$ after setting RSTN bit = "0" until the device is completely reset internally when the conversion mode is changed to DoP mode from PCM mode. DoP signal should be stopped $4/f_s$ after setting RSTN bit = "0" until the device is completely reset internally when the conversion mode is changed to PCM from DoP mode.

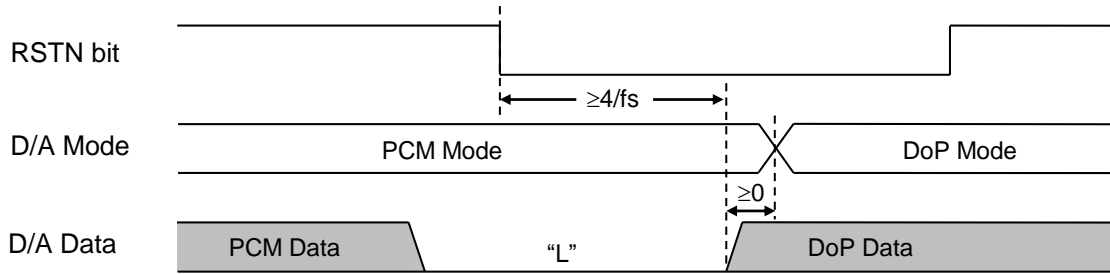

Figure 22. D/A Mode Switching Timing (from PCM to DoP)

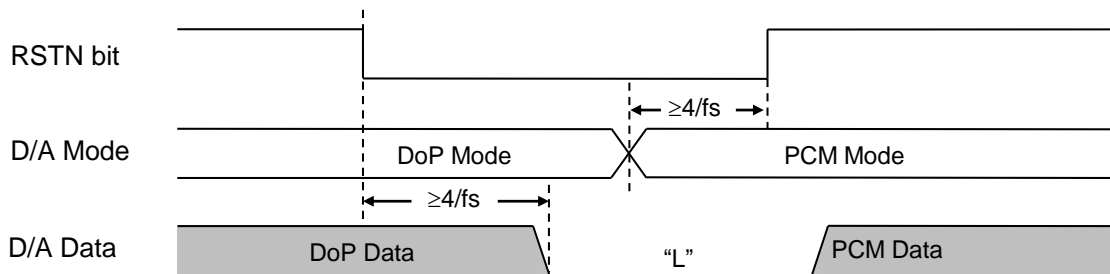

Figure 23. D/A Mode Switching Timing (from DoP to PCM)

9.2.3. DSD Playback Path Select (DSD mode, DoP mode)

In DSD or DoP mode, the DATT SoftMute circuit and the $\Delta\Sigma$ Modulator can be bypassed. DSDD bit switches DSD playback path (Table 5).

Table 5. DSD Playback Path Select

| DSDD bit | Mode |
|----------|---------------|
| 0 | Normal Path |
| 1 | Volume Bypass |

(default)

When the volume bypass path is selected, following four functions and related registers are invalid since the DATT SoftMute circuit and the $\Delta\Sigma$ Modulator are bypassed.

- Digital Filter Selection Function
(Refer to [9.5.2 DSD mode, DoP mode](#))
- Digital Attenuation
(Refer to [9.7 Digital Attenuation](#))
- Zero Detection Function
(Refer to [9.8.1 Zero Detection](#))
- Soft Mute Function
(Refer to [9.12 Soft Mute Operation](#))

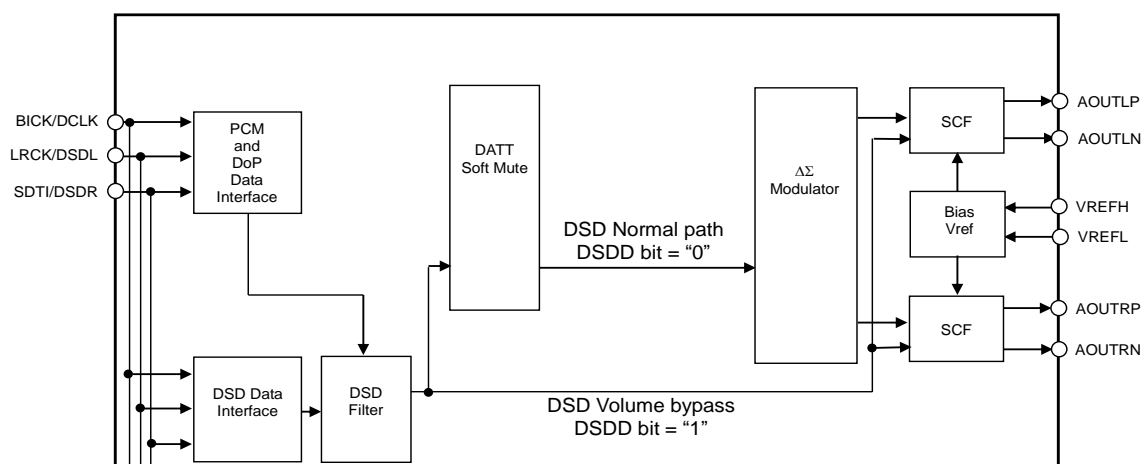

Figure 24. DSD Playback path
Normal path (DSDD bit = "0"), Volume bypass (DSDD bit = "1")

9.3. System Clock

9.3.1. PCM mode

The external clocks, which are required to operate the AK4462, are MCLK, BICK and LRCK. MCLK, BICK and LRCK should be synchronized but the phase of MCLK is not critical. MCLK is used to operate the interpolator, the $\Delta\Sigma$ modulator and SCF.

There are Manual Setting Mode and Auto Setting Mode for sampling speed setting and MCLK, LRCK frequency settings (Table 6). In Pin Control Mode, it will be in Auto Setting Mode forcibly.

Table 6. System Clock Setting Mode @Register Control Mode

| ACKS bit | Mode |
|----------|-------------------------------|
| 0 | Manual setting Mode (default) |
| 1 | Auto setting Mode |

All circuits except control registers and internal LDO (if LDOE pin = "H") of the AK4462 are automatically placed in power down state when MCLK is stopped for more than 1 μ s during normal operation, and the analog output becomes Hi-Z state (Table 43).

When MCLK is input again, the AK4462 exits this power down state and starts operation again. In this case, register settings are not initialized. The AK4462 is in power down state and the analog output is floating state until MCLK, BICK and LRCK are supplied.

MCLK frequency must be changed while the AK4462 is in reset state by setting the PDN pin = "L" or RSTN bit = "0".

9.3.1.1. Manual Setting Mode (ACKS bit = "0")

In manual setting mode, sampling speed is set by DFS[2:0] bits (Table 7). The MCLK frequency corresponding to each sampling speed should be provided externally (Table 8, Table 9). The AK4462 is in manual setting mode when power down is released (PDN pin = "L" → "H"). After changing the sampling speed by DFS[2:0] bits, reset the AK4462 once by setting RSTN bit. This function is only supported in register control mode.

Table 7. PCM Sampling Speed Setting (Manual Setting Mode)

| DFS[2:0] bits | Sampling Speed | Sampling Rate (fs) |
|---------------|-------------------|--------------------|
| 000 | Normal Speed Mode | 7.2–54 kHz |
| 001 | Double Speed Mode | 54–108 kHz |
| 010 | Quad Speed Mode | 108–216 kHz |
| 011 | Quad Speed Mode | 108–216 kHz |
| 100 | Oct Speed Mode | 216–388 kHz |
| 101 | Hex Speed Mode | 388–776 kHz |
| 110 | Oct Speed Mode | 216–388 kHz |
| 111 | Hex Speed Mode | 388–776 kHz |

(default)

Table 8. System Clock Example (Manual Setting Mode) (N/A: Not available)

| LRCK fs | MCLK (MHz) | | | | | | Sampling Speed |
|------------|------------|---------|---------|---------|---------|---------|-------------------|
| | 16fs | 32fs | 48fs | 64fs | 96fs | 128fs | |
| 32.0 kHz | N/A | N/A | N/A | N/A | N/A | N/A | Normal |
| 44.1 kHz | N/A | N/A | N/A | N/A | N/A | N/A | |
| 48.0 kHz | N/A | N/A | N/A | N/A | N/A | N/A | |
| 88.2 kHz | N/A | N/A | N/A | N/A | N/A | N/A | Double |
| 96.0 kHz | N/A | N/A | N/A | N/A | N/A | N/A | |
| 176.4 kHz | N/A | N/A | N/A | N/A | N/A | 22.5792 | Quad |
| 192.0 kHz | N/A | N/A | N/A | N/A | N/A | 24.5760 | |
| 352.8 kHz | N/A | 11.2896 | 16.9344 | 22.5792 | 33.8688 | N/A | Oct |
| 384.0 kHz | N/A | 12.2880 | 18.4320 | 24.5760 | 36.8640 | N/A | |
| 705.6 kHz | 11.2896 | 22.5792 | 33.8688 | 45.1584 | N/A | N/A | Hex |
| 768.0 kHz | 12.2880 | 24.5760 | 36.8640 | 49.1520 | N/A | N/A | |

Table 9. System Clock Example (Manual Setting Mode) (N/A: Not available)

| LRCK fs | MCLK (MHz) | | | | | | | Sampling Speed |
|------------|------------|---------|---------|---------|---------|---------|---------|-------------------|
| | 192fs | 256fs | 384fs | 512fs | 768fs | 1024fs | 1152fs | |
| 32.0 kHz | N/A | 8.1920 | 12.2880 | 16.3840 | 24.5760 | 32.7680 | 36.8640 | Normal |
| 44.1 kHz | N/A | 11.2896 | 16.9344 | 22.5792 | 33.8688 | N/A | N/A | |
| 48.0 kHz | N/A | 12.2880 | 18.4320 | 24.5760 | 36.8640 | N/A | N/A | |
| 88.2 kHz | N/A | 22.5792 | 33.8688 | 45.1584 | N/A | N/A | N/A | Double |
| 96.0 kHz | N/A | 24.5760 | 36.8640 | 49.1520 | N/A | N/A | N/A | |
| 176.4 kHz | 33.8688 | 45.1584 | N/A | N/A | N/A | N/A | N/A | Quad |
| 192.0 kHz | 36.8640 | 49.1520 | N/A | N/A | N/A | N/A | N/A | |
| 352.8 kHz | N/A | N/A | N/A | N/A | N/A | N/A | N/A | Oct |
| 384.0 kHz | N/A | N/A | N/A | N/A | N/A | N/A | N/A | |
| 705.6 kHz | N/A | N/A | N/A | N/A | N/A | N/A | N/A | Hex |
| 768.0 kHz | N/A | N/A | N/A | N/A | N/A | N/A | N/A | |

9.3.1.2. Auto Setting Mode (ACKS bit = "1")

In Auto Setting Mode, the MCLK and LRCK frequency ratio is detected to automatically set the Sampling Speed Mode (Table 10). Therefore, sampling speed setting by DFS[2:0] bits is not necessary. The frequencies of MCLK corresponding to each Sampling Speed Mode should be input externally (Table 11, Table 12). In Pin Control Mode, the AK4462 will be in Auto Setting Mode forcibly.

Table 10. Sampling Speed (Auto Setting Mode)

| MCLK | | Sampling Speed |
|-------------|-------------|----------------------|
| 1024fs | 1152fs | Normal (fs ≤ 32 kHz) |
| 512fs/256fs | 768fs/384fs | Normal |
| 256fs | 384fs | Double |
| 128fs | 192fs | Quad |
| 64fs | 96fs | Oct |
| 32fs | 48fs | Hex |

Table 11. System Clock Example (Auto Setting Mode) (N/A: Not available)

| LRCK fs | MCLK (MHz) | | | | | | Sampling Speed |
|------------|------------|---------|---------|---------|---------|---------|-------------------|
| | 32fs | 48fs | 64fs | 96fs | 128fs | 192fs | |
| 32.0 kHz | N/A | N/A | N/A | N/A | N/A | N/A | Normal |
| 44.1 kHz | N/A | N/A | N/A | N/A | N/A | N/A | |
| 48.0 kHz | N/A | N/A | N/A | N/A | N/A | N/A | |
| 88.2 kHz | N/A | N/A | N/A | N/A | N/A | N/A | |
| 96.0 kHz | N/A | N/A | N/A | N/A | N/A | N/A | Double |
| 176.4 kHz | N/A | N/A | N/A | N/A | 22.5792 | 33.8688 | |
| 192.0 kHz | N/A | N/A | N/A | N/A | 24.5760 | 36.8640 | Quad |
| 352.8 kHz | N/A | N/A | 22.5792 | 33.8688 | N/A | N/A | |
| 384.0 kHz | N/A | N/A | 24.5760 | 36.8640 | N/A | N/A | Oct |
| 705.6 kHz | 22.5792 | 33.8688 | N/A | N/A | N/A | N/A | |
| 768.0 kHz | 24.5760 | 36.8640 | N/A | N/A | N/A | N/A | Hex |

Table 12. System Clock Example (Auto Setting Mode) (N/A: Not available)

| LRCK fs | MCLK (MHz) | | | | | | Sampling Speed |
|------------|------------|------------|---------|---------|---------|---------|-------------------|
| | 256fs | 384fs | 512fs | 768fs | 1024fs | 1152fs | |
| 32.0 kHz | 8.1920(*) | 12.2880(*) | 16.3840 | 24.5760 | 32.7680 | 36.8640 | Normal |
| 44.1 kHz | 11.2896(*) | 16.9344(*) | 22.5792 | 33.8688 | N/A | N/A | |
| 48.0 kHz | 12.2880(*) | 18.4320(*) | 24.5760 | 36.8640 | N/A | N/A | |
| 88.2 kHz | 22.5792 | 33.8688 | N/A | N/A | N/A | N/A | |
| 96.0 kHz | 24.5760 | 36.8640 | N/A | N/A | N/A | N/A | Double |
| 176.4 kHz | N/A | N/A | N/A | N/A | N/A | N/A | |
| 192.0 kHz | N/A | N/A | N/A | N/A | N/A | N/A | Quad |
| 352.8 kHz | N/A | N/A | N/A | N/A | N/A | N/A | |
| 384.0 kHz | N/A | N/A | N/A | N/A | N/A | N/A | Oct |
| 705.6 kHz | N/A | N/A | N/A | N/A | N/A | N/A | |
| 768.0 kHz | N/A | N/A | N/A | N/A | N/A | N/A | Hex |

When MCLK = 256fs/384fs, Auto Setting Mode supports sampling rates of 8–96 kHz. However, the Dynamic Range and S/N performances will degrade approximately 3 dB if the sampling rate is under 54 kHz (values with (*) in Table 12) due to the internal oversampling ratio being reduced by one half comparing with when MCLK = 512fs/768fs (Table 13).

Table 13. Relationship between Dynamic Range, S/N and MCLK Frequency (fs = 44.1 kHz)

| ACKS bit | MCLK | Dynamic Range, S/N (A-weighted) |
|----------|-------------------------|------------------------------------|
| 0 | 256fs/384fs/512fs/768fs | 117 dB |
| 1 | 256fs/384fs | 114 dB |
| 1 | 512fs/768fs | 117 dB |

9.3.2. DSD mode (Register Control mode only)

The external clocks that are required in DSD mode are MCLK and DCLK. MCLK should be synchronized with DCLK but the phase is not critical. The frequency of MCLK is set by DCKS bit (Table 14). The AK4462 is automatically placed in standby state when MCLK is stopped during normal operation, and the analog output becomes Hi-Z state. When the reset is released (RSTN bit = “0”→“1”), the AK4462 is in standby state until MCLK and DCLK are input.

Table 14. System Clock (DSD mode, fs=32kHz, 44.1kHz, 48kHz)

| DCKS bit | MCLK Frequency | DCLK Frequency |
|----------|----------------|----------------------------------|
| 0 | 512fs | 64fs/128fs/256fs/512fs (default) |
| 1 | 768fs | 64fs/128fs/256fs/512fs |

The AK4462 supports DSD data stream rates of DSD64, DSD128, DSD256 and DSD512 modes. The data sampling speed is selected by DSDSEL[1:0] bits (Table 15).

Table 15. DSD data stream select

| DSDSEL[1:0] bits | DSD mode | DCLK Frequency | DSD data stream | | | |
|---------------------|-------------|-------------------|-----------------|---------------|-------------|-----------|
| | | | fs = 32 kHz | fs = 44.1 kHz | fs = 48 kHz | |
| 00 | DSD64 | 64fs | 2.048 MHz | 2.8224 MHz | 3.072 MHz | (default) |
| 01 | DSD128 | 128fs | 4.096 MHz | 5.6448 MHz | 6.144 MHz | |
| 10 | DSD256 | 256fs | 8.192 MHz | 11.2896 MHz | 12.288 MHz | |
| 11 | DSD512 | 512fs | 16.284 MHz | 22.5792 MHz | 24.576 MHz | |

9.3.3. DoP mode (Register Control mode only)

The external clocks that are required in DSD mode are MCLK, BICK and LRCK. MCLK, BICK and LRCK should be synchronized but the phase of MCLK is not critical. The frequency of MCLK is set by DCKS bit (Table 16).

Table 16. Master Clock Setting (DoP Mode)

| DCKS bit | MCLK Frequency | |
|----------|-----------------------|-----------|
| 0 | 22.5792 or 24.576 MHz | (default) |
| 1 | 33.8688 or 36.864 MHz | |

There are Manual Setting Mode and Auto Setting Mode for sampling speed setting and MCLK, LRCK frequency settings. There are Manual Setting Mode and Auto Setting Mode for sampling speed setting and MCLK, LRCK frequency settings (Table 17).

Table 17. System Clock Setting Mode @Register Control Mode

| ACKS bit | Mode | |
|----------|---------------------|-----------|
| 0 | Manual setting Mode | (default) |
| 1 | Auto setting Mode | |

9.3.3.1. Manual Setting Mode (DoP mode)

In Manual Setting Mode, sampling speed is set by DOPSEL[1:0] bits (Table 18). The MCLK frequency corresponding to each sampling speed should be provided externally (Table 19, Table 20). After changing the sampling speed by DOPSEL[1:0] bits, reset the AK4462 once by setting RSTN bit.

Table 18. PCM Sampling Speed Setting (x: Do not Care)

| DOPSEL [1:0] bits | Sampling Speed | DSD Data Stream (MHz) | LRCK (kHz) |
|-------------------|----------------|-----------------------|------------|
| 00 (default) | DoP64 | 2.8224 | 176.4 |
| | | 3.072 | 192 |
| 01 | DoP128 | 5.6448 | 352.8 |
| | | 6.144 | 384 |
| 1x | DoP256 | 11.2896 | 705.6 |
| | | 12.288 | 768 |

Table 19. System Clock Example in DoP Mode (Manual setting Mode, DCKS bit = "0")
(N/A: Not available)

| LRCK | MCLK(MHz) | | | | | | Sampling Speed |
|-----------|-----------|---------|---------|---------|----------|----------|----------------|
| | 32 LRCK | 48 LRCK | 64 LRCK | 96 LRCK | 128 LRCK | 192 LRCK | |
| 176.4 kHz | N/A | N/A | N/A | N/A | 22.5792 | N/A | DoP64 |
| 192.0 kHz | N/A | N/A | N/A | N/A | 24.5760 | N/A | |
| 352.8 kHz | N/A | N/A | 22.5792 | N/A | N/A | N/A | DoP128 |
| 384.0 kHz | N/A | N/A | 24.5760 | N/A | N/A | N/A | |
| 705.6 kHz | 22.5792 | N/A | N/A | N/A | N/A | N/A | DoP256 |
| 768.0 kHz | 24.5760 | N/A | N/A | N/A | N/A | N/A | |

Table 20. System Clock Example in DoP Mode (Manual setting Mode, DCKS bit = "1")
(N/A: Not available)

| LRCK | MCLK(MHz) | | | | | | Sampling Speed |
|-----------|-----------|---------|---------|---------|----------|----------|----------------|
| | 32 LRCK | 48 LRCK | 64 LRCK | 96 LRCK | 128 LRCK | 192 LRCK | |
| 176.4 kHz | N/A | N/A | N/A | N/A | N/A | 33.8688 | DoP64 |
| 192.0 kHz | N/A | N/A | N/A | N/A | N/A | 36.8640 | |
| 352.8 kHz | N/A | N/A | N/A | 33.8688 | N/A | N/A | DoP128 |
| 384.0 kHz | N/A | N/A | N/A | 36.8640 | N/A | N/A | |
| 705.6 kHz | N/A | 33.8688 | N/A | N/A | N/A | N/A | DoP256 |
| 768.0 kHz | N/A | 36.8640 | N/A | N/A | N/A | N/A | |

9.3.3.2. Auto Setting Mode (DoP mode)

In Auto Setting Mode, the MCLK and LRCK frequency ratio is detected to automatically set the Sampling Speed Mode. Therefore, sampling speed setting by DOPSEL[1:0] is not necessary. The frequencies of MCLK corresponding to each Sampling Speed Mode should be input externally (Table 21, Table 22).

Table 21. System Clock Example in DoP Mode (Auto setting Mode DCKS bit = "0")
(N/A: Not available)

| LRCK | MCLK(MHz) | | | | | | Sampling Speed |
|-----------|-----------|---------|---------|---------|----------|----------|----------------|
| | 32 LRCK | 48 LRCK | 64 LRCK | 96 LRCK | 128 LRCK | 192 LRCK | |
| 176.4 kHz | N/A | N/A | N/A | N/A | 22.5792 | N/A | DoP64 |
| 192.0 kHz | N/A | N/A | N/A | N/A | 24.5760 | N/A | |
| 352.8 kHz | N/A | N/A | 22.5792 | N/A | N/A | N/A | DoP128 |
| 384.0 kHz | N/A | N/A | 24.5760 | N/A | N/A | N/A | |
| 705.6 kHz | 22.5792 | N/A | N/A | N/A | N/A | N/A | DoP256 |
| 768.0 kHz | 24.5760 | N/A | N/A | N/A | N/A | N/A | |

Table 22. System Clock Example in DoP Mode (Auto setting Mode, DCKS bit = "1")
(N/A: Not available)

| LRCK | MCLK(MHz) | | | | | | Sampling Speed |
|-----------|-----------|---------|---------|---------|----------|----------|----------------|
| | 32 LRCK | 48 LRCK | 64 LRCK | 96 LRCK | 128 LRCK | 192 LRCK | |
| 176.4 kHz | N/A | N/A | N/A | N/A | N/A | 33.8688 | DoP64 |
| 192.0 kHz | N/A | N/A | N/A | N/A | N/A | 36.8640 | |
| 352.8 kHz | N/A | N/A | N/A | 33.8688 | N/A | N/A | DoP128 |
| 384.0 kHz | N/A | N/A | N/A | 36.8640 | N/A | N/A | |
| 705.6 kHz | N/A | 33.8688 | N/A | N/A | N/A | N/A | DoP256 |
| 768.0 kHz | N/A | 36.8640 | N/A | N/A | N/A | N/A | |

9.4. Audio Interface Format

9.4.1. PCM mode

Four data modes, such as Normal Mode, TDM128, TDM256, and TDM512 Modes, are available. Mode settings are available by the pins (TDM0/1 pins and DIF pin) and registers (TDM[1:0] bits and DIF[2:0] bits). However, it should not be changed during operation. The AK4462 must be reset by setting RSTN bit when the format setting is changed during operation.

9.4.1.1. Input Data Format (Pin Control Mode)

Normal Mode (TDM1 pin = “L”, TDM0 pin = “L”)

2ch Data is shifted in via the SDTI pin using BICK and LRCK inputs. Two data formats are supported and selected by the DIF pin as shown in [Table 23](#). In all formats the serial data is MSB first, 2's compliment format and is read on the rising edge of BICK.

TDM128 Mode (TDM1 pin = “L”, TDM0 pin = “H”)

4ch Data is shifted in via the SDTI pin using BICK and LRCK inputs. However, only the first 2 data slots in [Figure 42](#) are available. BICK is fixed to 128fs. Two data formats are supported and selected by the DIF pin as shown in [Table 23](#). In all formats the serial data is MSB first, 2's compliment format and is read on the rising edge of BICK.

TDM256 Mode (TDM1 pin = “H”, TDM0 pin = “L”)

8ch Data is shifted in via the SDTI pin using BICK and LRCK inputs. However, only the first 2 data slots in [Figure 43](#) are available. BICK is fixed to 256fs. Two data formats are supported and selected by the DIF pin as shown in [Table 23](#). In all formats the serial data is MSB first, 2's compliment format and is read on the rising edge of BICK.

TDM512 Mode (TDM1 pin = “H”, TDM0 pin = “H”)

16ch Data is shifted in via the SDTI pin using BICK and LRCK inputs. However, only the first 2 data slots in [Figure 44](#) are available. BICK is fixed to 512fs. Two data formats are supported and selected by the DIF pin as shown in [Table 23](#). In all formats the serial data is MSB first, 2's compliment format and is read on the rising edge of BICK.

Table 23. Audio Interface Format (@Pin Control Mode)

| Mode | | TDM1 pin | TDM0 pin | DIF pin | SDTI Format | LRCK | BICK | Figure |
|---------------------------------------|----|----------|----------|---------|------------------------------------|------|-------|---------------------------|
| Normal (Note 41) | 6 | L | L | L | 32-bit MSB justified | H/L | ≥64fs | Figure 30 |
| | 7 | L | L | H | 32-bit I ² S compatible | L/H | ≥64fs | Figure 31 |
| TDM128 | 12 | L | H | L | 32-bit MSB justified | H/L | 128fs | Figure 32 |
| | 13 | L | H | H | 32-bit I ² S compatible | L/H | 128fs | Figure 33 |
| TDM256 | 18 | H | L | L | 32-bit MSB justified | H/L | 256fs | Figure 35 |
| | 19 | H | L | H | 32-bit I ² S compatible | L/H | 256fs | Figure 36 |
| TDM512 | 24 | H | H | L | 32-bit MSB justified | H/L | 512fs | Figure 38 |
| | 25 | H | H | H | 32-bit I ² S compatible | L/H | 512fs | Figure 39 |

(default)

Note 41. The number of cycles of BICK must be the same as the bit length of setting format or more.

9.4.1.2. Input Data Format (Register Control Mode)

Normal Mode (TDM[1:0] bits = "00")

2ch Data is shifted in via the SDTI pin using BICK and LRCK inputs. Eight data formats are supported and selected by the DIF[2:0] bits as shown in (Table 24). In all formats the serial data is MSB first, 2's compliment format and is read on the rising edge of BICK. Mode 2 can be used for 16-bit and 20-bit and Mode 6 can be used for 16-bit, 20-bit and 24-bit MSB justified formats by zeroing the unused LSBs. Refer to [9.4.1.3 Data Slot Selection Function](#) for options to route data to DAC outputs.

TDM128 Mode (TDM[1:0] bits = "01")

4ch Data is shifted in via the SDTI pin using BICK and LRCK inputs. BICK is fixed to 128fs. Eight data formats are supported and selected by the DIF[2:0] bits as shown in (Table 24). In all formats the serial data is MSB first, 2's compliment format and is read on the rising edge of BICK. Refer to [9.4.1.3 Data Slot Selection Function](#) for options to route data to DAC outputs.

TDM256 Mode (TDM[1:0] bits = "10")

8ch Data is shifted in via the SDTI pin using BICK and LRCK inputs. BICK is fixed to 256fs. Eight data formats are supported and selected by the DIF[2:0] bits as shown in (Table 24). In all formats the serial data is MSB first, 2's compliment format and is read on the rising edge of BICK. Refer to [9.4.1.3 Data Slot Selection Function](#) for options to route data to DAC outputs.

TDM512 Mode (TDM[1:0] bits = "11")

16ch Data is shifted in via the SDTI pin using BICK and LRCK inputs. BICK is fixed to 512fs. Eight data formats are supported and selected by the DIF[2:0] bits as shown in (Table 24). In all formats the serial data is MSB first, 2's compliment format and is read on the rising edge of BICK. Refer to [9.4.1.3 Data Slot Selection Function](#) for options to route data to DAC outputs.

Table 24. Audio Interface Format (@Register Control Mode) (N/A: Not available)

| Mode | | TDM[1:0] bits | DIF[2:0] bits | SDTI Format | LRCK | BICK | Figure |
|---------------------|-----|------------------------------------|------------------|------------------------------------|---------------------------|-------|---------------------------|
| Normal (Note 42) | 0 | 00 | 000 | 16-bit LSB justified | H/L | 32fs | Figure 25 |
| | 1 | | 001 | 20-bit LSB justified | H/L | ≥40fs | Figure 26 |
| | 2 | | 010 | 24-bit MSB justified | H/L | ≥48fs | Figure 27 |
| | 3 | | 011 | 16-bit I ² S compatible | L/H | 32fs | Figure 28 |
| | | | | 24-bit I ² S compatible | L/H | ≥48fs | |
| | 4 | | 100 | 24-bit LSB justified | H/L | ≥48fs | Figure 26 |
| | 5 | | 101 | 32-bit LSB justified | H/L | ≥64fs | Figure 29 |
| | 6 | | 110 | 32-bit MSB justified | H/L | ≥64fs | Figure 30 |
| 7 | 111 | 32-bit I ² S compatible | L/H | ≥64fs | Figure 31 | | |
| TDM128 | | 01 | 000 | N/A | N/A | N/A | N/A |
| | | | 001 | N/A | N/A | N/A | N/A |
| | 8 | | 010 | 24-bit MSB justified | H/L | 128fs | Figure 32 |
| | 9 | | 011 | 24-bit I ² S compatible | L/H | 128fs | Figure 33 |
| | 10 | | 100 | 24-bit LSB justified | H/L | 128fs | Figure 34 |
| | 11 | | 101 | 32-bit LSB justified | H/L | 128fs | Figure 32 |
| | 12 | | 110 | 32-bit MSB justified | H/L | 128fs | |
| | 13 | | 111 | 32-bit I ² S compatible | L/H | 128fs | Figure 33 |
| TDM256 | | 10 | 000 | N/A | N/A | N/A | N/A |
| | | | 001 | N/A | N/A | N/A | N/A |
| | 14 | | 010 | 24-bit MSB justified | H/L | 256fs | Figure 35 |
| | 15 | | 011 | 24-bit I ² S compatible | L/H | 256fs | Figure 36 |
| | 16 | | 100 | 24-bit LSB justified | H/L | 256fs | Figure 37 |
| | 17 | | 101 | 32-bit LSB justified | H/L | 256fs | Figure 35 |
| | 18 | | 110 | 32-bit MSB justified | H/L | 256fs | |
| | 19 | | 111 | 32-bit I ² S compatible | L/H | 256fs | Figure 36 |
| TDM512 | | 11 | 000 | N/A | N/A | N/A | N/A |
| | | | 001 | N/A | N/A | N/A | N/A |
| | 20 | | 010 | 24-bit MSB justified | H/L | 512fs | Figure 38 |
| | 21 | | 011 | 24-bit I ² S compatible | L/H | 512fs | Figure 39 |
| | 22 | | 100 | 24-bit LSB justified | H/L | 512fs | Figure 40 |
| | 23 | | 101 | 32-bit LSB justified | H/L | 512fs | Figure 38 |
| | 24 | | 110 | 32-bit MSB justified | H/L | 512fs | |
| | 25 | | 111 | 32-bit I ² S compatible | L/H | 512fs | Figure 39 |

(default)

Note 42. The number of cycles of BICK must be the same as the bit length of setting format or more.

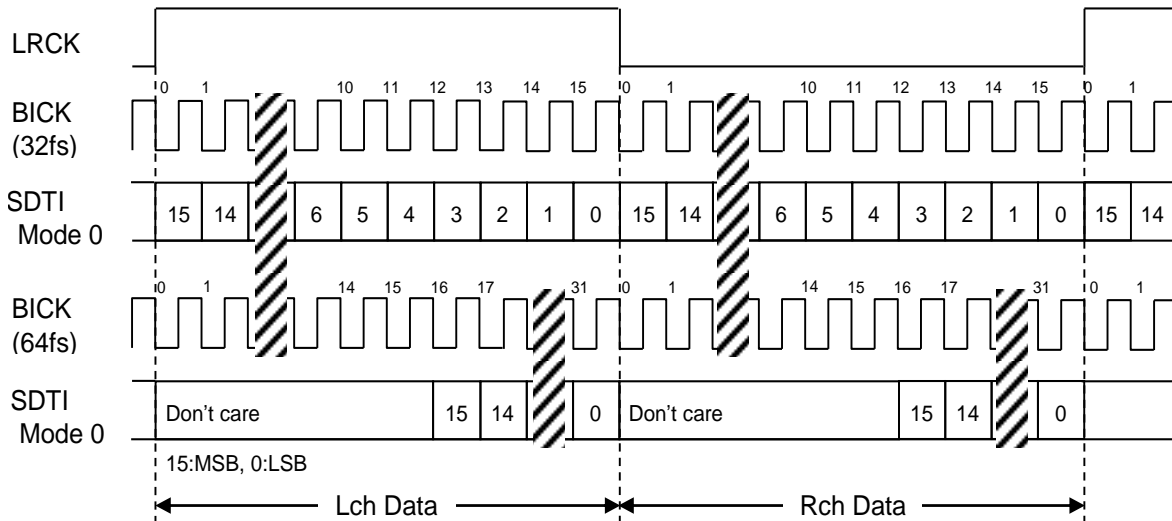

Figure 25. Mode 0 Timing

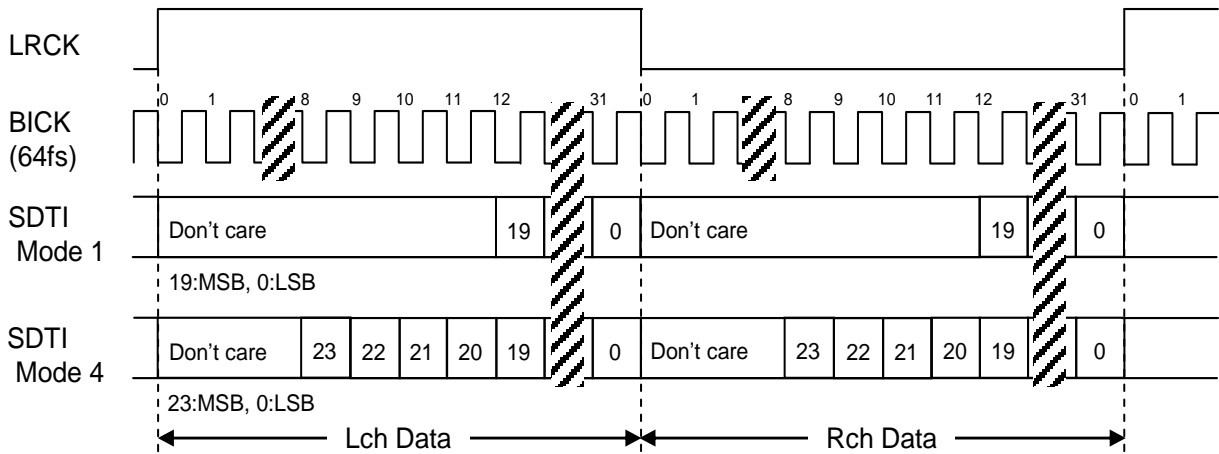

Figure 26. Mode 1, 4 Timing

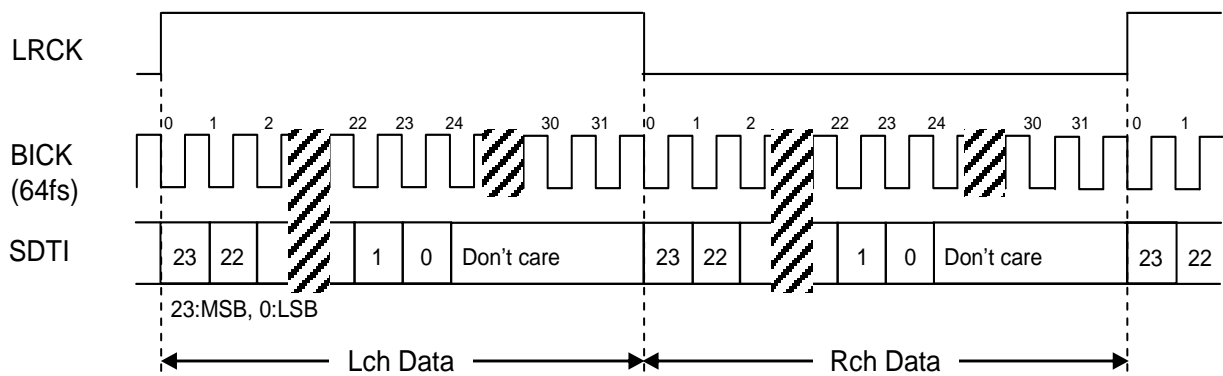

Figure 27. Mode 2 Timing

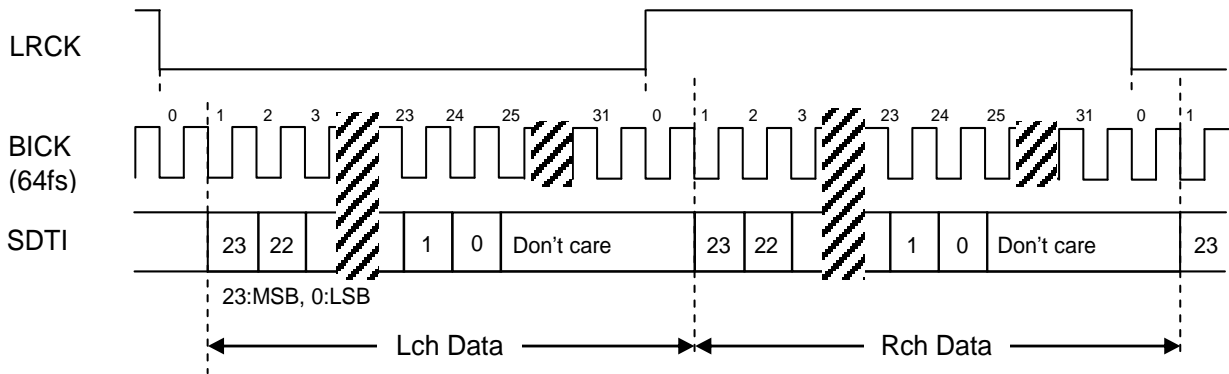

Figure 28. Mode 3 Timing

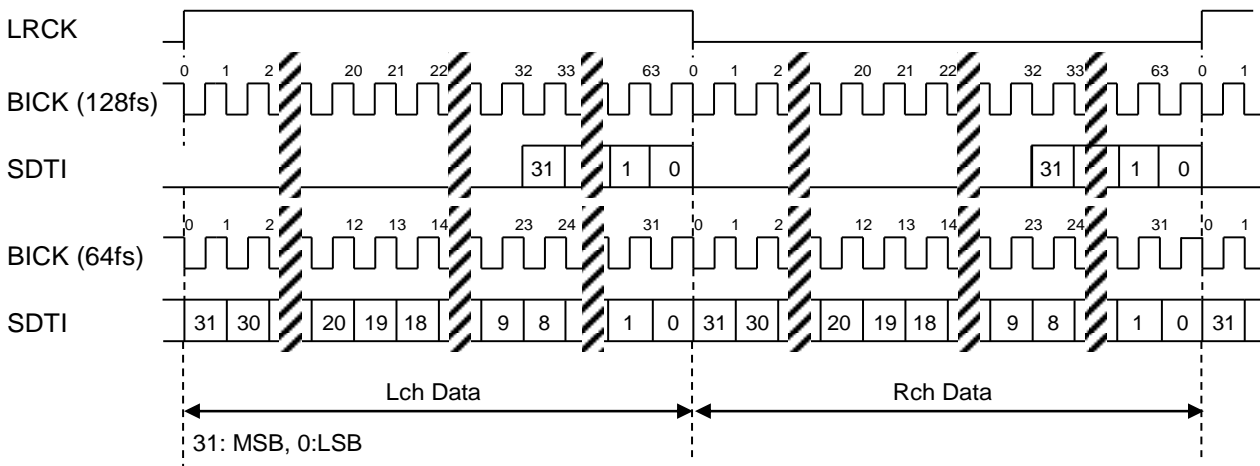

Figure 29. Mode 5 Timing

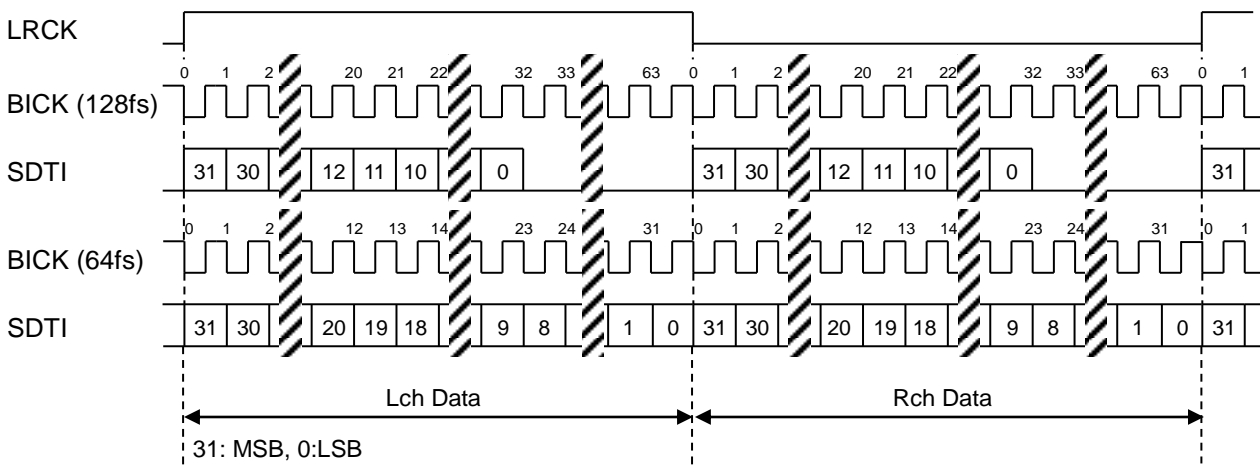

Figure 30. Mode 6 Timing

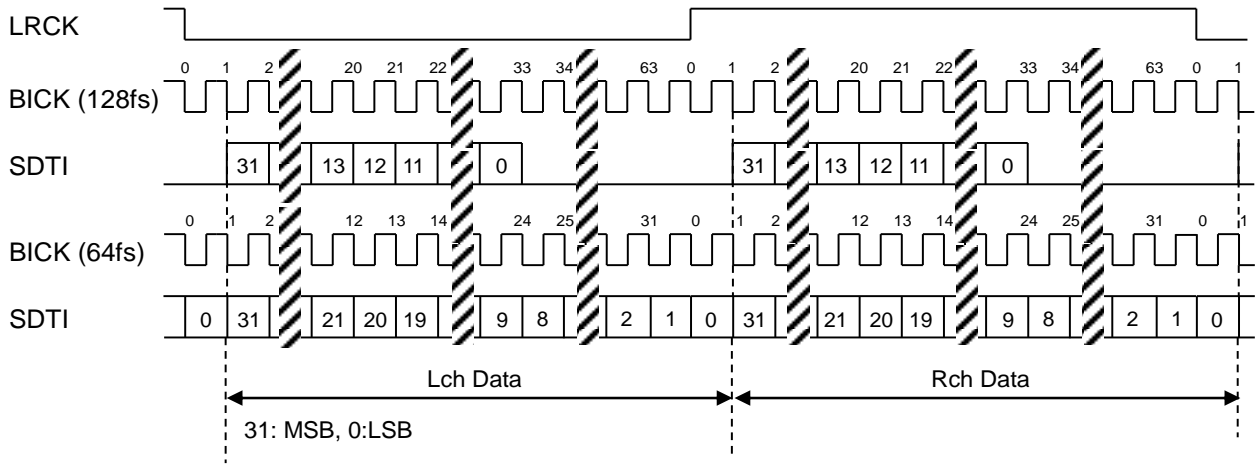

Figure 31. Mode 7 Timing

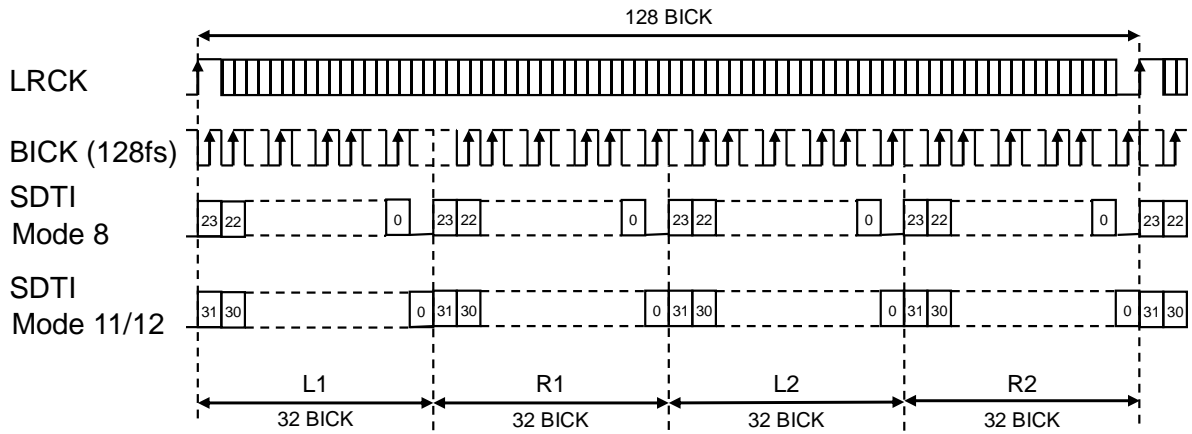

Figure 32. Mode 8/11/12 Timing

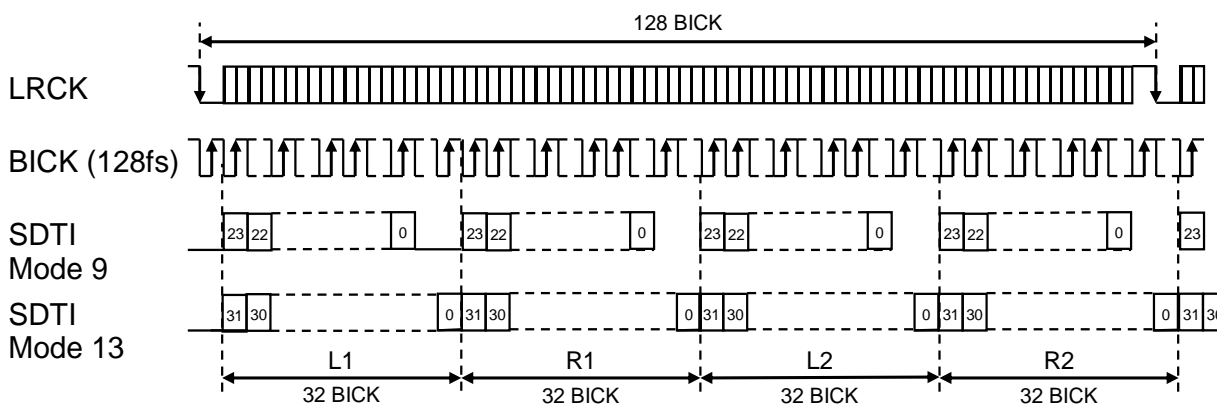

Figure 33. Mode 9/13 Timing

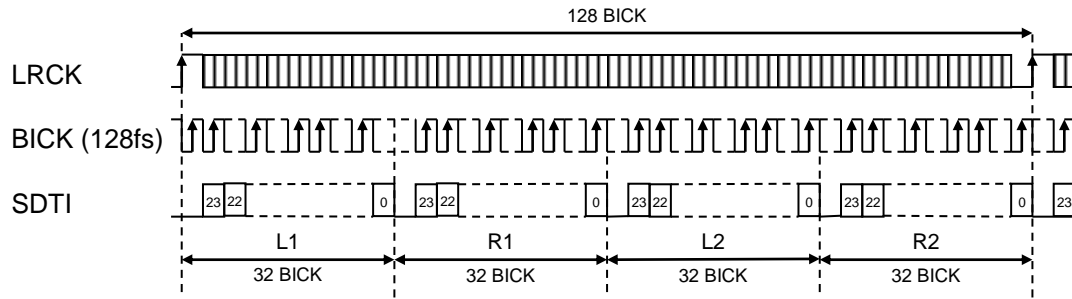

Figure 34. Mode 10 Timing

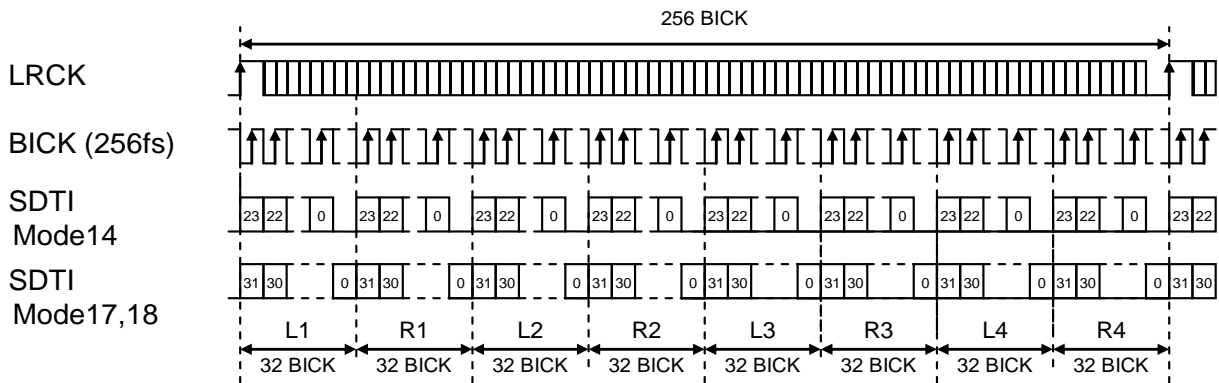

Figure 35. Mode 14/17/18 Timing

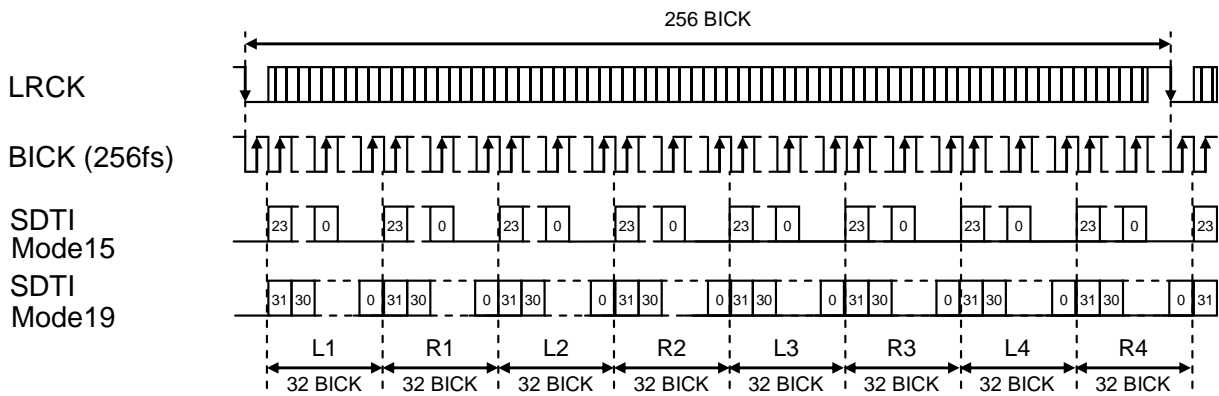

Figure 36. Mode 15/19 Timing

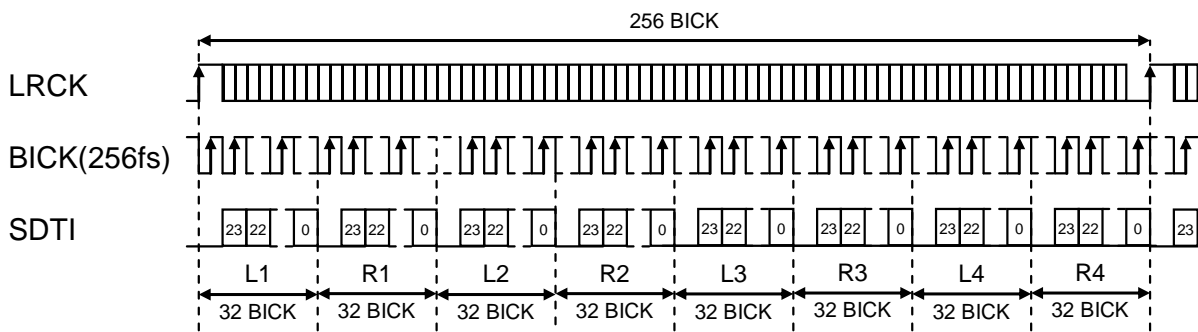

Figure 37. Mode 16 Timing

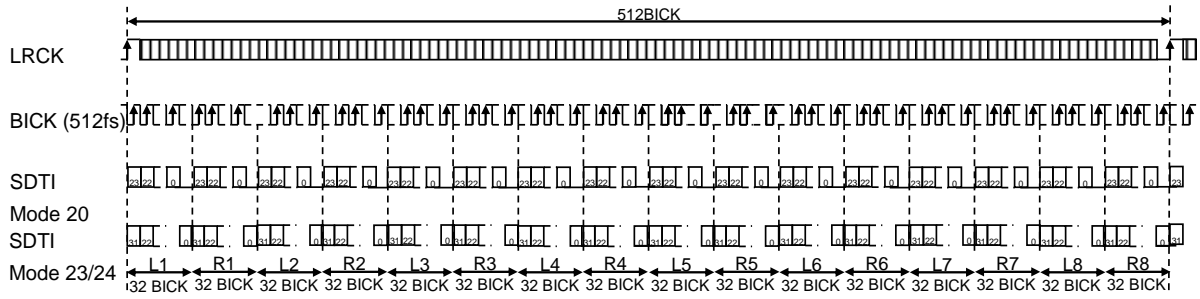

Figure 38. Mode 20/23/24 Timing

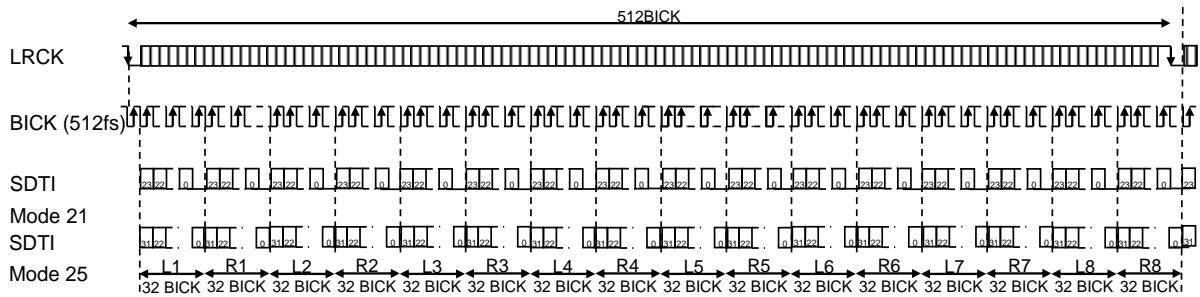

Figure 39. Mode 21/25 Timing

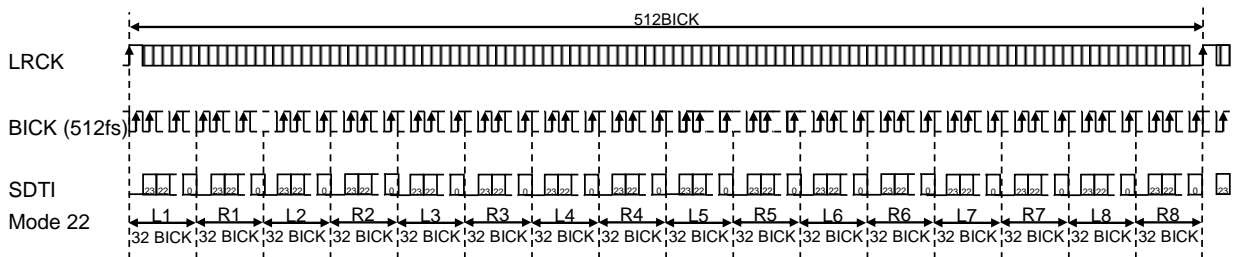

Figure 40. Mode 22 Timing

9.4.1.3. Data Slot Selection Function

Data slot of 1 cycle LRCK for each audio data format is defined as Figure 41, Figure 42, Figure 43 and Figure 44. DAC output data can be selected by SDS[2:0] bits (Register Control Mode only), as shown in Table 25.

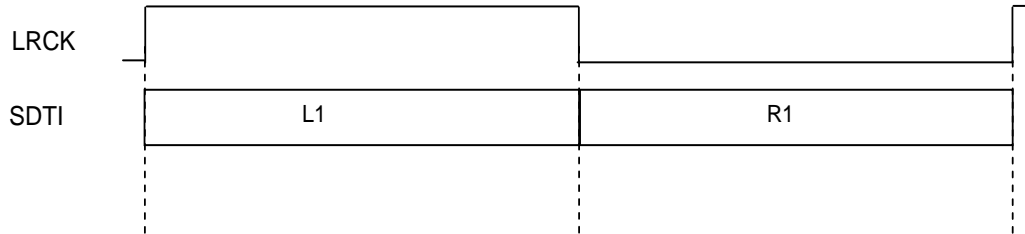

Figure 41. Data Slot in Normal Mode

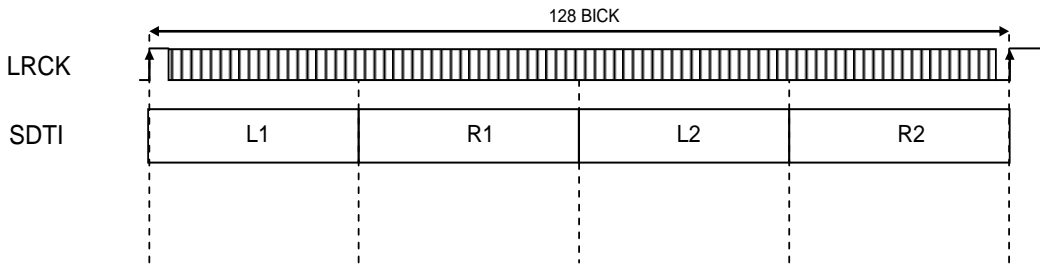

Figure 42. Data Slot in TDM128 Mode

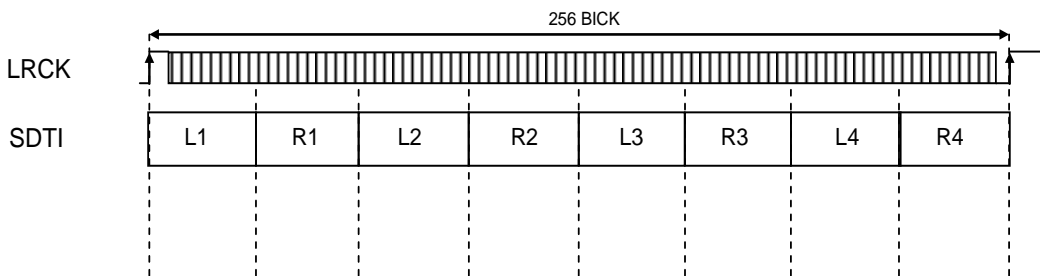

Figure 43. Data Slot in TDM256 Mode

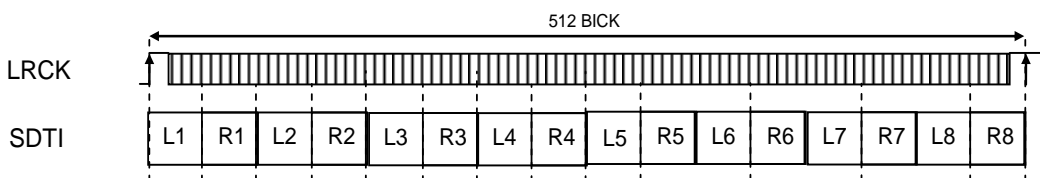

Figure 44. Data Slot in TDM512 Mode

Table 25. Data Select (x: Do not care)

| | TDM[1:0] bits | SDS[2:0] bits | DAC | |
|--------|---------------|---------------|-----|-----|
| | | | Lch | Rch |
| Normal | 00 | xxx | L1 | R1 |
| TDM128 | 01 | xx0 | L1 | R1 |
| | | xx1 | L2 | R2 |
| TDM256 | 10 | x00 | L1 | R1 |
| | | x01 | L2 | R2 |
| | | x10 | L3 | R3 |
| | | x11 | L4 | R4 |
| TDM512 | 11 | 000 | L1 | R1 |
| | | 001 | L2 | R2 |
| | | 010 | L3 | R3 |
| | | 011 | L4 | R4 |
| | | 100 | L5 | R5 |
| | | 101 | L6 | R6 |
| | | 110 | L7 | R7 |
| | | 111 | L8 | R8 |

9.4.2. DSD mode (Register Control mode only)

2ch Data is shifted in via the DSDL and DSDR pins using DCLK inputs. DSD data is supported by both Normal mode (Figure 45) and Phase Modulation mode (Figure 46). The AK4462 does not support phase modulation when DCLK is 512fs (DSDSEL[1:0] bits = "11").

Polarity of DCLK is possible to invert by DCKB bit. Input data is clocked in on a rising edge of DCLK when DCKB bit = "0" and it is clocked in on a falling edge of DCLK when DCKB bit = "1".

In case of DSD mode, the setting of DIF[2:0] bits is ignored.

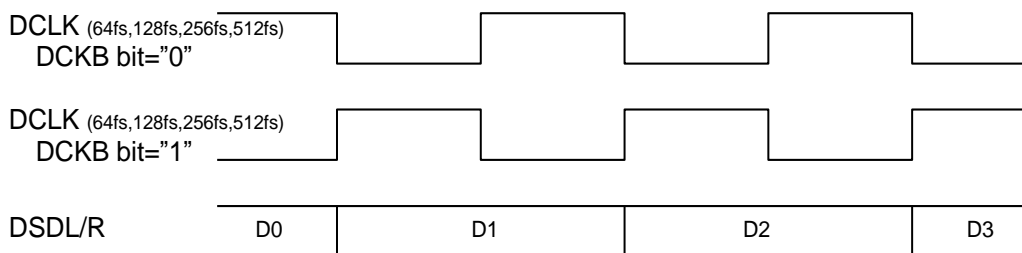

Figure 45. DSD mode Timing

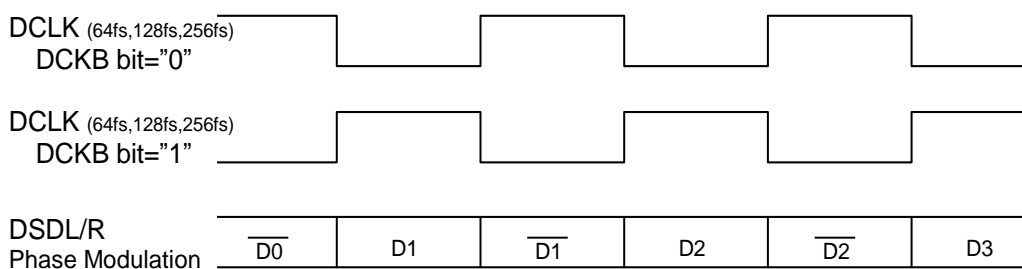

Figure 46. DSD mode Timing (Phase Modulation Format)

9.4.3. DoP mode

DoP mode is the mode which transmits DSD data by using over PCM data format.

9.4.3.1. DoP mode Input Data Format

In DoP mode, a signal for 1 channel consists of 8-bit DoP marker slot and 16-bit data slot is stored in a 24-bit PCM frame. PCM frame data for 2 channels is input to the SDTI pin by BICK and LRCK. Six kinds of data format can be selected by DIF[2:0] bits (Table 26). Do not set DIF[2:0] bits = “000” or DIF[2:0] bits = “001” during DoP mode.

In all modes, input data is clocked in on a rising edge of BICK. When DIF[2:0] bits is “101”, “110” or “111”, input 0 for lower 8-bit of the data slot (Figure 49, Figure 50). The number of cycles of BICK must be the same as the bit length of setting format.

Table 26. DoP Input Data Format Setting (N/A: Not available)

| DIF[2:0] Bits | SDTI Format | LRCK | BICK | Figure |
|---------------|------------------------------------|------|----------------------|-----------|
| 000 | N/A | N/A | N/A | N/A |
| 001 | N/A | N/A | N/A | N/A |
| 010 | 24-bit MSB justified | H/L | 24 pulse / PCM frame | Figure 47 |
| 011 | 24-bit I ² S compatible | L/H | 24 pulse / PCM frame | Figure 48 |
| 100 | 24-bit LSB justified | H/L | 24 pulse / PCM frame | Figure 47 |
| 101 | 32-bit LSB justified | H/L | 32 pulse / PCM frame | Figure 49 |
| 110 | 32-bit MSB justified | H/L | 32 pulse / PCM frame | Figure 49 |
| 111 | 32-bit I ² S compatible | L/H | 32 pulse / PCM frame | Figure 50 |

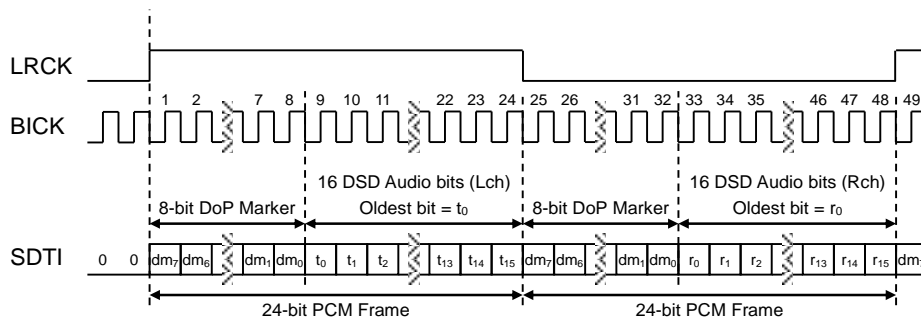

Figure 47. 24-bit MSB justified and 24-bit LSB justified (DIF[2:0] bits = “010”, “100”)

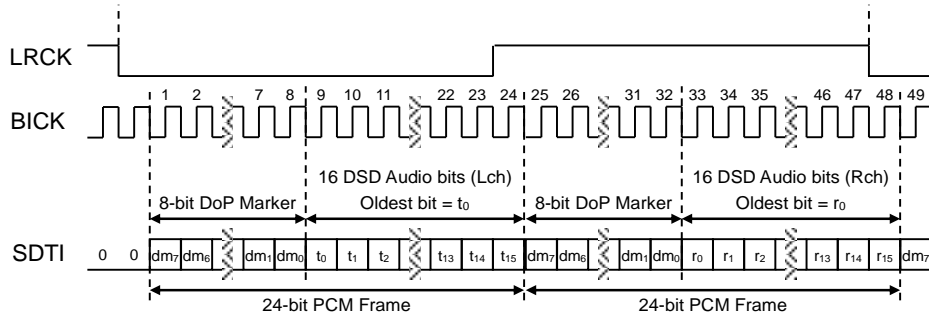

Figure 48. 24-bit I²S compatible (DIF[2:0] bits = "011")

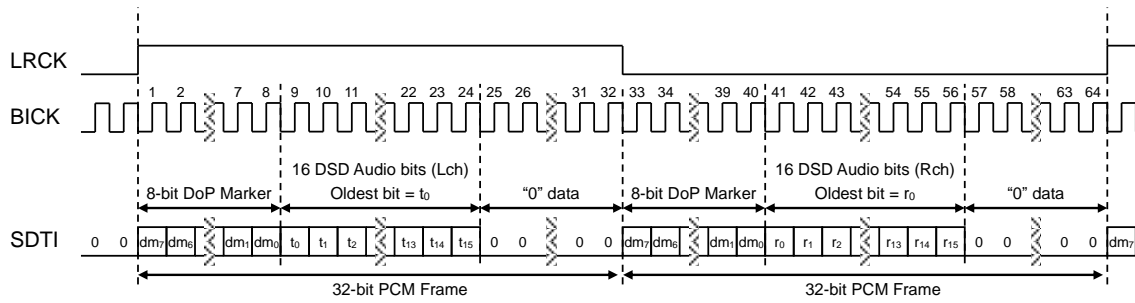

Figure 49. 32-bit MSB justified and 32-bit LSB justified (DIF[2:0] bits = "101", "110")

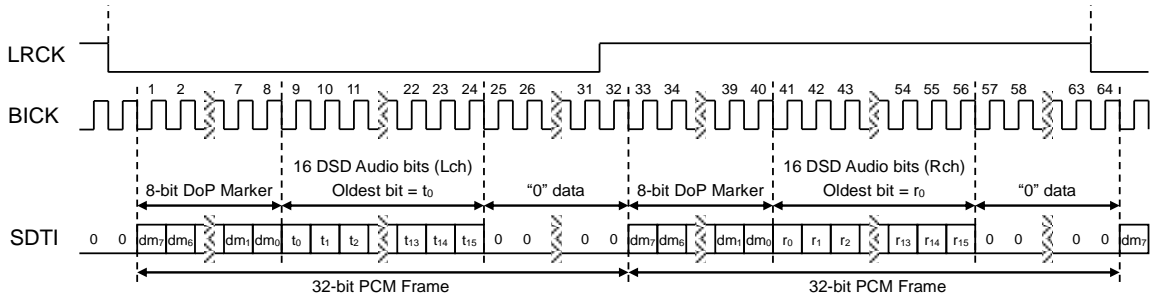

Figure 50. 32-bit I²S compatible (DIF[2:0] bits = "111")

9.4.3.2. DoP Marker

DoP marker is a marker to distinguish PCM frame input data as DoP data. It should be input as the first 8-bit (DoP marker slot) of a 24-bit PCM frame data and the same marker should be input in one LRCK cycle.

In DoP mode, the AK4462 starts playback of DoP signal if DOP marker is input more than 32LRCK cycle (64 PCM frame) continuously. EVEN (default: 05H) and ODD (default: FAH) DoP markers should be input alternately for every LRCK cycle (Figure 51).

If a code other than DoP marker is input to the DoP marker slot, the AK4462 behaves differently according to the switching mode. When the AK4462 is in manual setting DoP mode (DOP bit = "1", ADOPE bit = "0"), the input data is over written to 0 internally and the analog output will be zero output status which is fixed to $(VREFH+VREFL)/2$. When the AK4462 is in PCM/DoP automatic switching mode, the AK4462 distinguishes data mode as PCM and processes PCM playback. Refer to "9.11 PCM/DoP Automatic Mode Switching Function" for details about PCM/DoP automatic switching mode.

When the output status is changed, there is a possibility that click noise occurs since output switching between normal playback and zero output status is executed instantaneously.

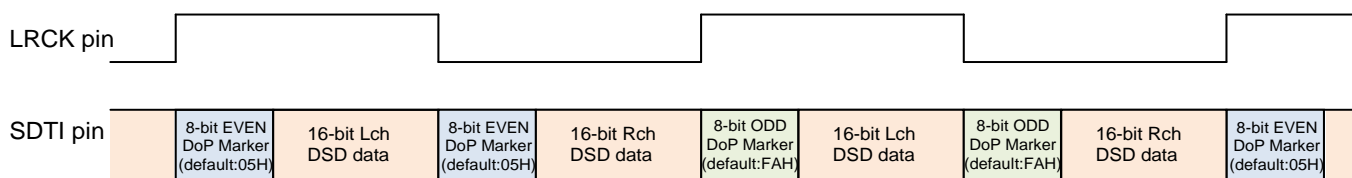

Figure 51. DoP Marker (BICK = 48LRCK)

9.4.3.3. DoP Marker Setting

DoP marker can be selected by setting DMMI bit in the AK4462 (Table 27). When DMMI bit = "1", EVEN marker can be set by DMIE[7:0] bits and ODD marker can be set by DMIO[7:0] bits arbitrarily.

Table 27. DoP Marker Setting

| DMMI bit | EVEN Marker | ODD Marker | |
|----------|----------------|----------------|-----------|
| 0 | 05H | FAH | (default) |
| 1 | DMIE[7:0] bits | DMIO[7:0] bits | |

When using DoP Marker Setting (DMMI bit = "1"), setting DMIE[7:0] bits and DMIO[7:0] bits to "00H" or "FFH" is prohibited. Furthermore, do not set the same value with DMIE[7] bit and DMIO[7] bit. For example, if DMIE[7] bit is set to "1", DMIO[7] bit should be set to "0".

9.5. Digital Filter

Six types of digital filter in PCM mode and two types of digital filter in DSD/DoP mode are available in the AK4462 for sound color selection of music playback.

9.5.1. PCM mode

In PCM mode, the digital filter is available as shown in [Table 28](#). The digital filter can be selected by the SD, SLOW and SSLOW bits if the AK4462 is in Register Control Mode and the sampling speed is in Normal, Double and Quad Speed Mode ([Table 29](#)).

Table 28. Digital Filter(@PCM mode) Setting Table by Control Mode

| Sampling Speed | Control Mode | |
|----------------|---|---|
| | Pin | Register |
| Normal | Short delay sharp roll-off filter (fixed) | Selectable (Table 29) |
| Double | | |
| Quad | | |
| Oct | Super slow roll-off filter (fixed) | |
| Hex | | |

Table 29. Digital Filter (@PCM mode) Setting Table by Control Register (x: do not care)

| SSLOW bit | SD bit | SLOW bit | Mode |
|-----------|--------|----------|-----------------------------------|
| 0 | 0 | 0 | Sharp roll-off filter |
| 0 | 0 | 1 | Slow roll-off filter |
| 0 | 1 | 0 | Short delay sharp roll-off filter |
| 0 | 1 | 1 | Short delay slow roll-off filter |
| 1 | 0 | x | Super slow roll-off filter |
| 1 | 1 | x | Low dispersion short delay filter |

(default)

9.5.2. DSD mode, DoP mode

When DSDD bit = "0", two kinds of digital filters are available by setting DSDF bit ([Table 30](#)). Only one digital filter is available when DSDD bit = "1". Filter characteristics are different when DSDSEL[1:0] bits = "11" comparing to other settings such as "00", "01" or "01". [Table 30](#) shows the cutoff frequency @fs = 44.1 kHz. The cutoff frequency tracks the sampling frequency (fs).

Table 30. Digital Filter (@DSD mode) Setting Table (x: do not care)

| DSDD bit | DSDF bit | Cut Off Frequency @fs = 44.1 kHz | | | |
|----------|----------|---------------------------------------|---|---|----------------------------------|
| | | DSDSEL[1:0] bits = "00" (DSD64/DoP64) | DSDSEL[1:0] bits = "01" (DSD128/DoP128) | DSDSEL[1:0] bits = "10" (DSD256/DoP256) | DSDSEL[1:0] bits = "11" (DSD512) |
| 0 | 0 | 39 kHz | 78 kHz | 156 kHz | 312 kHz |
| | 1 | 76 kHz | 152 kHz | 304 kHz | 608 kHz |
| 1 | x | 76 kHz | 152 kHz | 304 kHz | 1230 kHz |

(default)

9.6. De-emphasis Filter (PCM mode)

A digital deemphasis filter is available for 32 kHz, 44.1 kHz or 48 kHz sampling rates ($t_c = 50/15\mu s$) and is enabled or disabled by the DEM[1:0] bits (Table 31). This function is valid only in PCM Normal Speed Mode. DEM[1:0] bits are ignored in DSD and DoP modes. DEM setting value is held even if the data mode is switched between PCM, DSD and DoP modes.

Table 31. De-emphasis Control (Register Control Mode)

| DEM[1:0] bits | Mode |
|---------------|---------|
| 00 | 44.1kHz |
| 01 | OFF |
| 10 | 48kHz |
| 11 | 32kHz |

(default)

9.7. Digital Attenuation

The AK4462 includes channel independent digital attenuation for output volumes (ATT) with 256 levels at 0.5 dB step including MUTE (Table 32). When changing output levels, it is executed in soft transition, thus no switching noise occurs during these transitions. It can attenuate the input data from 0 dB to -127 dB and MUTE when assuming the output signal level is 0dB when ATTL[7:0] bits and ATTR[7:0] bits = "FFH".

Table 32. Attenuation level of Digital Attenuator

| ATTL[7:0] bits ATTR[7:0] bits | Attenuation Level (PCM mode) | Attenuation Level (DSD mode, DoP mode) |
|----------------------------------|---------------------------------|---|
| FFH | +0 dB | +0 dB |
| FEH | -0.5 dB | -0.5 dB |
| FDH | -1.0 dB | -1.0 dB |
| : | : | : |
| 03H | -126.0 dB | -126.0 dB |
| 02H | -126.5 dB | MUTE ($-\infty$) |
| 01H | -127.0 dB | MUTE ($-\infty$) |
| 00H | MUTE ($-\infty$) | MUTE ($-\infty$) |

(default)

The transition time of when changing digital output volume is defined as (Transition time of 1 code shift) x (previous ATT level - changed ATT level). The transition time of 1 code shift is set by ATS[1:0] bits (Table 33). Register setting values will be kept even switching the PCM, DSD and DoP modes.

Table 33. Attenuation Transition Time Setting

| ATS[1:0] bits | Transition Time of 1 code shift | | | Attenuation Transition Time from "FFH" to "00H" | | |
|------------------|---------------------------------|----------|---------------|--|----------|-----------------|
| | PCM mode | DSD mode | DoP mode | PCM mode | DSD mode | DoP mode |
| 00 | 16/fs | 16/fs | 16 LRCK cycle | 4080/fs | 4080/fs | 4080 LRCK cycle |
| 01 | 8/fs | 8/fs | 8 LRCK cycle | 2040/fs | 2040/fs | 2040 LRCK cycle |
| 10 | 2/fs | 2/fs | 2 LRCK cycle | 510/fs | 510/fs | 510 LRCK cycle |
| 11 | 1/fs | 1/fs | 1 LRCK cycle | 255/fs | 255/fs | 255 LRCK cycle |

It takes 4080/fs (92.5 ms @fs = 44.1 kHz) from "FFH" (0dB) to "00H" (MUTE) when ATS[1:0] bits = "0". ATTL[7:0] bits and ATTR[7:0] bits are initialized to "FFH" (0dB) by setting the PDN pin = "L". If the digital volume attenuation level is changed during reset period, the output volume will become a setting value after releasing the reset. It will change to a setting value immediately if the volume is changed within 10/fs after releasing reset.

9.8. Zero Detection, DSD Full-scale Detection

The AK4462 has a zero detection function and a DSD full-scale detection function. These detection flags can be output from the DZF pin. DDMOE bit (06H: D4) selects the output detection flag of the DZF pin. The output polarity of the DZF pin can be inverted by DZFB bit (02H: D2). The DZF pin goes “H” for zero/DSD full-scale detection when DZFB bit = “0”, the DZF pin goes “L” when DZFB bit = “1”. [Table 34](#) shows output signal settings of the DZF pin.

Table 34. Output Select for DZF Pin

| DDMOE bit | DZFB bit | DZF pin Output | |
|-----------|----------|--|-----------|
| 0 | 0 | Zero Detection Flag (“H” when detect zero) | (default) |
| | 1 | Zero Detection Flag (“L” when detect zero) | |
| 1 | 0 | DSD Full-scale Detection Flag (“H” when detect DSD full-scale) | |
| | 1 | DSD Full-scale Detection Flag (“L” when detect DSD full-scale) | |

When DDMOE bit is set to “1” in PCM mode, the DZF pin outputs “L” if DZFB bit = “0” and outputs “H” if DZFB bit = “1”.

9.8.1. Zero Detection

When the zero detection function is enabled, monitoring channels are selected by L bit and R bit (08H:D7, D6). In this case, both channels can be selected. As shown in [Figure 52](#), DATT soft mute block outputs are the monitor nodes. Zero detection flag is generated when all monitor nodes of selected channels, whose corresponding (L or R) bit is set to “1”, are continuously “0” for a detection time shown in [Table 35](#). When both L and R bits are set to “1”, zero detection flag is generated if both L and R channels are “0” for a detection time shown in [Table 35](#). When both L and R bits are set to “0”, zero detection flag is not generated.

Table 35. zero Detection time

| | Sampling Speed | Detection Time |
|-----|-------------------------------|----------------|
| PCM | Normal/Double/Quad Speed mode | 8192/fs |
| | Oct/Hex Speed mode | 65536/fs |
| DSD | DSD64/128/256/512 | 4096/fs |
| DoP | DSD64/128/256 | 4096/fs |

Zero detection flag is cleared if any of data of the selected channel is no longer “0”.

Zero detection flag is generated immediately when the AK4462 is reset state (RSTN bit = “0”). Zero detection flag will be cleared in 4–5/fs by releasing reset (RSTN bit = “1”).

When AK4462 becomes standby state by PW bit = “0”, DZF pin holds last value. When AK4462 becomes standby state by stopping MCLK supply, DZF pin outputs zero detection flag immediately. Zero detection flag is output from the DZF pin. DZFB bit controls the polarity of zero detection flag ([Table 34](#)).

The zero detection function is disabled if Volume Bypass is selected in DSD mode ([Table 5](#)). In this case, the DZF pin outputs “H” if DZFB bit = “0” and outputs “L” if DZFB bit = “1”.

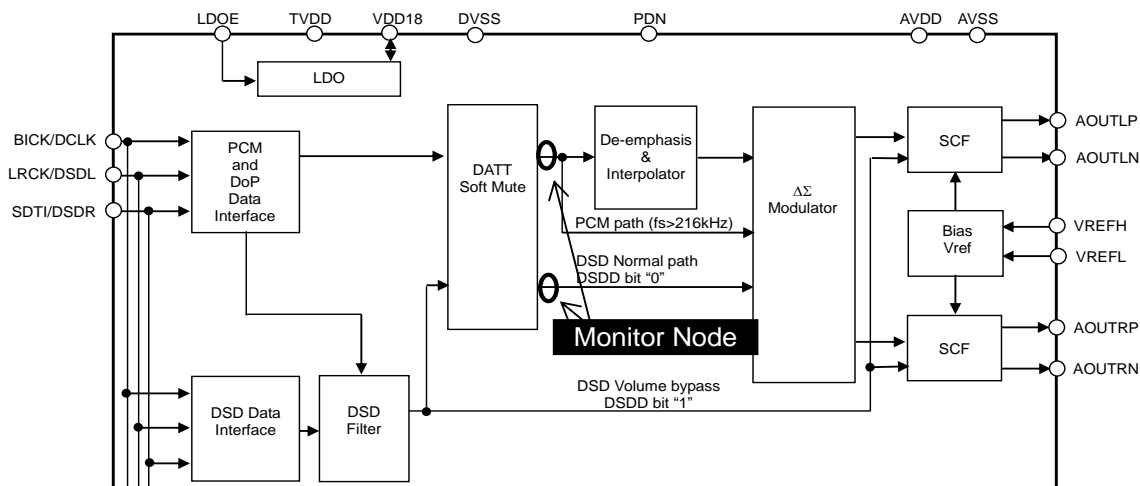

Figure 52. Zero Detection Monitor Node

9.8.2. DSD Full-Scale Detection (DSD mode, DoP mode)

The AK4462 has independent full-scale detection function for each channel in DSD and modes. Mute function of analog output signal becomes enabled after detecting full-scale signal by setting DDM bit = "1". (DDM bit setting should be made while PW bit = "0" or RSTN bit = "0")

Figure 53 shows a block diagram of DSD signal playback. Input data of each channel pin (DSDL or DSDR in DSD mode, SDTI in DoP mode) is received and full-scale detection is executed at the DSD full-scale detection block.

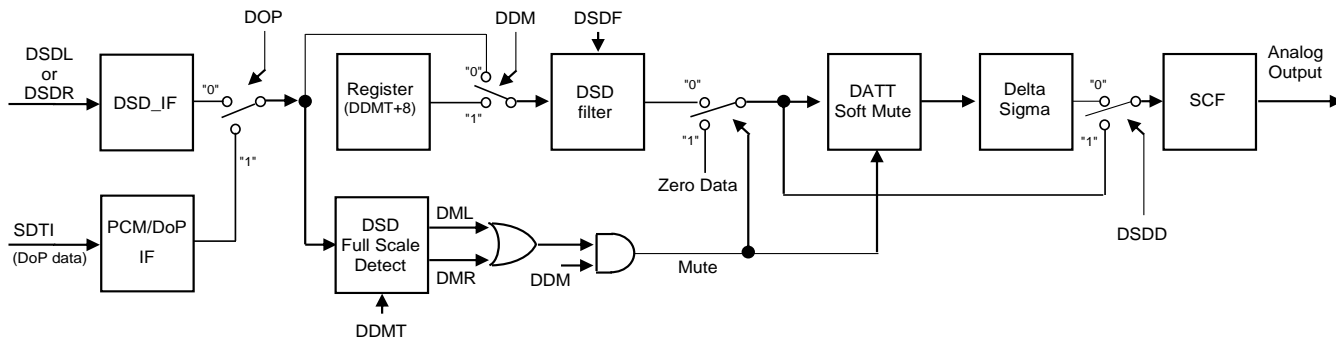

Figure 53. DSD Block Diagram

The AK4462 detects full-scale input and DML bit or DMR bit of detected channel will become "1" independently when L or R channel input data is kept "H" or "L" continuously for a detection time set by DDMT bit (Table 36). DML bit and DMR bit become "1" only when full-scale input is detected. These bits are "0" when full-scale input is not detected or the AK4462 is in PCM mode. DML bit or DMR bit status can be readout by reading register.

Full-scale detection signal can also be output from the DZF pin by setting DDMOE bit = "1". The DZF pin outputs DSD full-scale input detection flag of corresponding channel when one of L or R bit is set to "1". When both L and R bits are set to "0" or "1", the DZF pin outputs ORed signal of DSD full-scale input detection flag of all channels.

The AK4462 mutes the analog output when full-scale data is input to either L or R channel if DDM bit = "1". The output data of DSD_IF block is delayed by Register block for "Setting Time of DDMT bit + 8 DCLK cycles" to avoid clicking noise until the analog output is muted completely when DDM bit = "1". Therefore, the analog output delay becomes larger according to this delay time. (DDM bit setting should be made while PW bit = "0" or RSTN bit = "0")

Full-scale detection state is released when the input data of the full-scale input channel is toggled. The operation after full-scale detection is released is according to DSDD bit setting that selects DSD playback path (Table 37).

When DSDD bit = "0" (Normal Path), the transition time until the output data returns to normal after releasing full-scale detection state is according to the setting of ATS[1:0] bits (Table 33).
If DSDD bit = "1" (Volume Bypass), the output data returns to normal immediately when the full-scale detection state is released.

The full-scale detection function is assuming full-scale input that occurs when switching the data mode between PCM and DSD modes. Therefore, click noise will not occur when the input signal becomes full-scale from zero data and vice versa but there is a possibility that click noise occurs when the input signal becomes full-scale from the state there is an input signal and vice versa.

Table 36. DSD Full-scale Detection Time Setting

| DDMT bit | DSD mode | | DoP mode | | |
|----------|----------------|----------------|----------------|-----------------|-----------|
| | Detection Time | Register Delay | Detection Time | Register Delay | |
| 0 | 256 DCLK cycle | 264 DCLK cycle | 16 LRCK cycle | 16.5 LRCK cycle | (default) |
| 1 | 128 DCLK cycle | 136 DCLK cycle | 8 LRCK cycle | 8.5 LRCK cycle | |

Table 37. Relationship between Output Signal Transition Time and DSDD bit (DDM bit = "1")

| DSDD bit | Mode | Mute Transition time | Mute Release time | |
|----------|---------------|----------------------|-------------------|-----------|
| 0 | Normal Path | Rapidly | As ATS[1:0] bits | (default) |
| 1 | Volume Bypass | Rapidly | | |

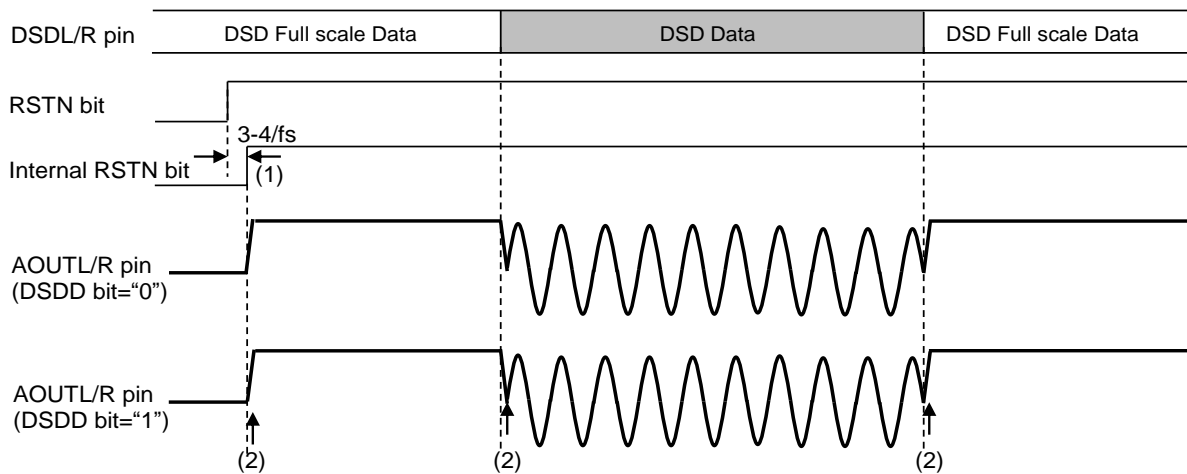

Notes:

- (1) Internal reset is released after $3-4/f_s$ by setting RSTN bit = "1".
- (2) Excessive signals will be output from the analog output if full-scale signal is input after releasing internal reset. This behavior does not depend on DSDD bit setting.

Figure 54. Analog Output Waveform with DSD Full-scale Input (DDM bit = "0")

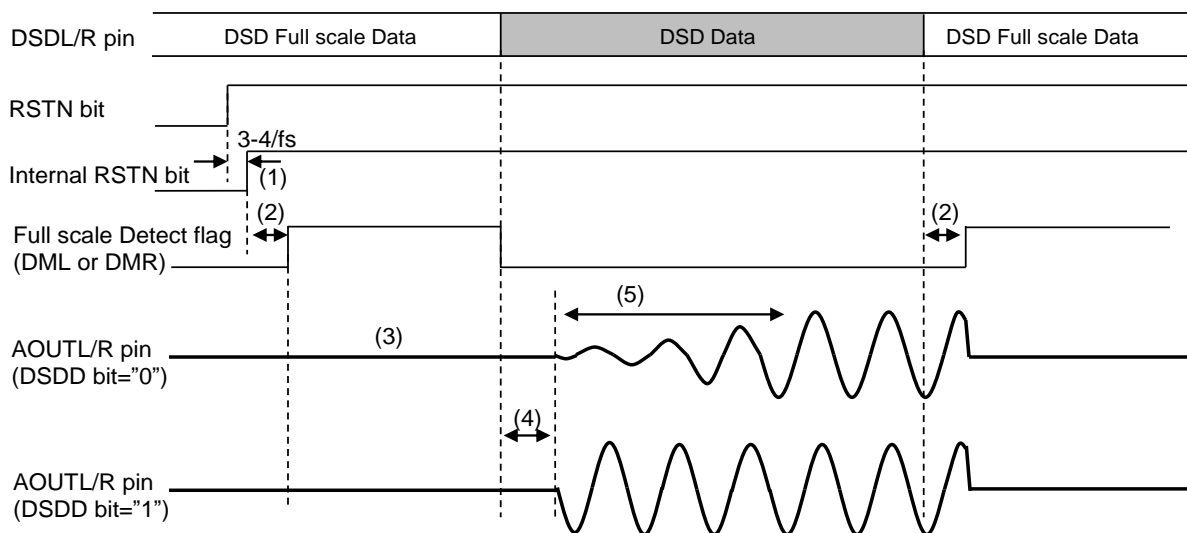

Notes:

- (1) Internal reset is released after $3-4/f_s$ by setting RSTN bit = "1".
- (2) The internal detection flag becomes "1" if the input data is full-scale for a period set by DDMT bit after releasing internal reset.
- (3) Analog output is forced to $(V_{REFL} + V_{REFR})/2$ when full-scale signal is detected. No clicking noise occurs during a period from digital data input until full-scale detection since the analog output data delays for Register delay time (Table 36) if DDM bit is set to "1".
- (4) Full-scale detection state is cleared when normal signal is input when the AK4462 is in full-scale detection state. Analog signal output starts after the Register delay time (Table 36) by clearing the full-scale detection state.
- (5) Analog output transition time is different according to DSDD bit setting. When DSDD bit = "0", analog output transition time is set by ATS[1:0] bits (Table 33). When DSDD bit = "1", analog output recovers immediately.

Figure 55. Analog Output Waveform with DSD Full-scale Input (DDM bit = "1")

9.9. LR Channel Output Signal Select, Phase Inversion Function

In register control mode, input and output combination of the AK4462 can be changed by MONO bits and SELLR bits. In addition, the output signal phase can be inverted by INV L bits and INVR bits (Table 38). These functions are available on all audio formats.

Table 38. Output Select (Register Control Mode)

| MONO bit | SELLR bit | INV L bit | INVR bit | Lch out (AOUTLN, AOUTLP pins) | Rch out (AOUTRN, AOUTRP pins) |
|----------|-----------|-----------|----------|----------------------------------|----------------------------------|
| 0 | 0 | 0 | 0 | Lch in | Rch in |
| | | 1 | 0 | Lch in Invert | Rch in |
| | | 0 | 1 | Lch in | Rch in Invert |
| | | 1 | 1 | Lch in Invert | Rch in Invert |
| 0 | 1 | 0 | 0 | Rch in | Lch in |
| | | 1 | 0 | Rch in Invert | Lch in |
| | | 0 | 1 | Rch in | Lch in Invert |
| | | 1 | 1 | Rch in Invert | Lch in Invert |
| 1 | 0 | 0 | 0 | Lch in | Lch in |
| | | 1 | 0 | Lch in Invert | Lch in |
| | | 0 | 1 | Lch in | Lch in Invert |
| | | 1 | 1 | Lch in Invert | Lch in Invert |
| 1 | 1 | 0 | 0 | Rch in | Rch in |
| | | 1 | 0 | Rch in Invert | Rch in |
| | | 0 | 1 | Rch in | Rch in Invert |
| | | 1 | 1 | Rch in Invert | Rch in Invert |

9.10. PCM/DSD Automatic Mode Switching Function

The AK4462 has automatic mode switching function that determines DSD or PCM mode from input signal of LRCK/DSDL pin (#4). This function is available by setting ADPE bit = "1" when the PDN pin = "H" in register control mode (Table 4). DP bit is for manual setting. It will be ignored when ADPE bit is "1". ADPE bit must be set while PW bit or RSTN bit = "0".

To prevent clicking noises on mode switching, the mute function of DSD full-scale detection should be enabled by setting DDM bit = "1" when using this automatic mode switching function. DDM bit must be set while PW bit or RSTN bit = "0".

Group delay will be 18/fs longer in PCM mode when setting ADPE bit = "1", and 136–264 DCLK cycle longer according to full-scale detection time setting by DDMT bit in DSD mode when setting DDM bit = "1" (Table 36).

Automatic detection result can be read out by ADP bit. ADP bit outputs "0" in PCM mode and "1" in DSD mode if ADPE bit = "1". The readout function of ADP bit is disabled if ADPE bit = "0" and "0" data is read out.

This function does not support DSD phase modulation format and edge inversion function of DSD receiving data (DCKB bit = "1").

9.10.1. Mode Judgement Start Condition

If one of the five conditions shown below is satisfied, the AK4462 executes mode detection. The AK4462 keeps previous mode instead of executing mode detection if any condition is not satisfied.

1. Input data of all channels are zero for a period set by ADPT[1:0] bits (Table 39)
2. Output data of all channels are zero for a period set by ADPT[1:0] bits because of attenuation (Table 39)
3. Input data of all channels are full-scale for a period set by DDMT bit in DSD mode (Table 36).
4. PW bit = "0"
5. RSTN bit = "0"

Table 39. Time Until Mode Detection after Input Data Becomes Zero

| ADPT[1:0] bits | Wait Time |
|----------------|---------------|
| 00 | 8192/fs+18/fs |
| 01 | 4096/fs+18/fs |
| 10 | 2048/fs+18/fs |
| 11 | 1024/fs+18/fs |

(default)

Note: fs = 30–48 kHz in DSD mode

9.10.2. Mode Detection

The AK4462 executes mode detection by comparing the input signal to the LRCK/DSDL pin to fixed code pattern. Input one of “01101001 01101001”, “01010101 01010101”, “00110011 00110011” code continuously to the LRCK/DSDL pin to transition to DSD mode from PCM mode (Table 40).

Input a clock toggles in $N \times 16\text{BICK}$ cycles (N must be an integral number greater than or equal to one) or a clock that keeps “L” or “H” for 32BICK cycles to the LRCK/DSDL pin to transition to PCM mode from DSD mode (Table 40). Refer to Figure 56, Figure 57 for the operation sequence.

The AK4462 keeps previous mode instead of executing mode detection if any condition is not satisfied.

Table 40. Input Signal when Switching PCM/DSD Modes

| #3 LRCK/DSDL Pin Input Signal | Detection Result |
|--|------------------|
| One of zero code pattern below is input twice consecutively “01101001 01101001” or “01010101 01010101” or “00110011 00110011” | DSD mode |
| Clock toggles in $N \times 16\text{BICK}$ cycles ($N \geq 1$) or Clock that keeps “L” or “H” for 32BICK cycles | PCM mode |

The AK4462 executes data mode detection even if there is no MCLK input. However, the analog output becomes Hi-Z and the AK4462 enters standby state when MCLK is stopped. The AK4462 resumes operation according to a data mode that is detected when MCLK is input again. The data mode will be maintained if the input clock to the BICK/DCLK pin is stopped.

The AK4462 executes internal reset for $3-4/f_s$ automatically when transition the data mode from DSD mode and resumes operation.

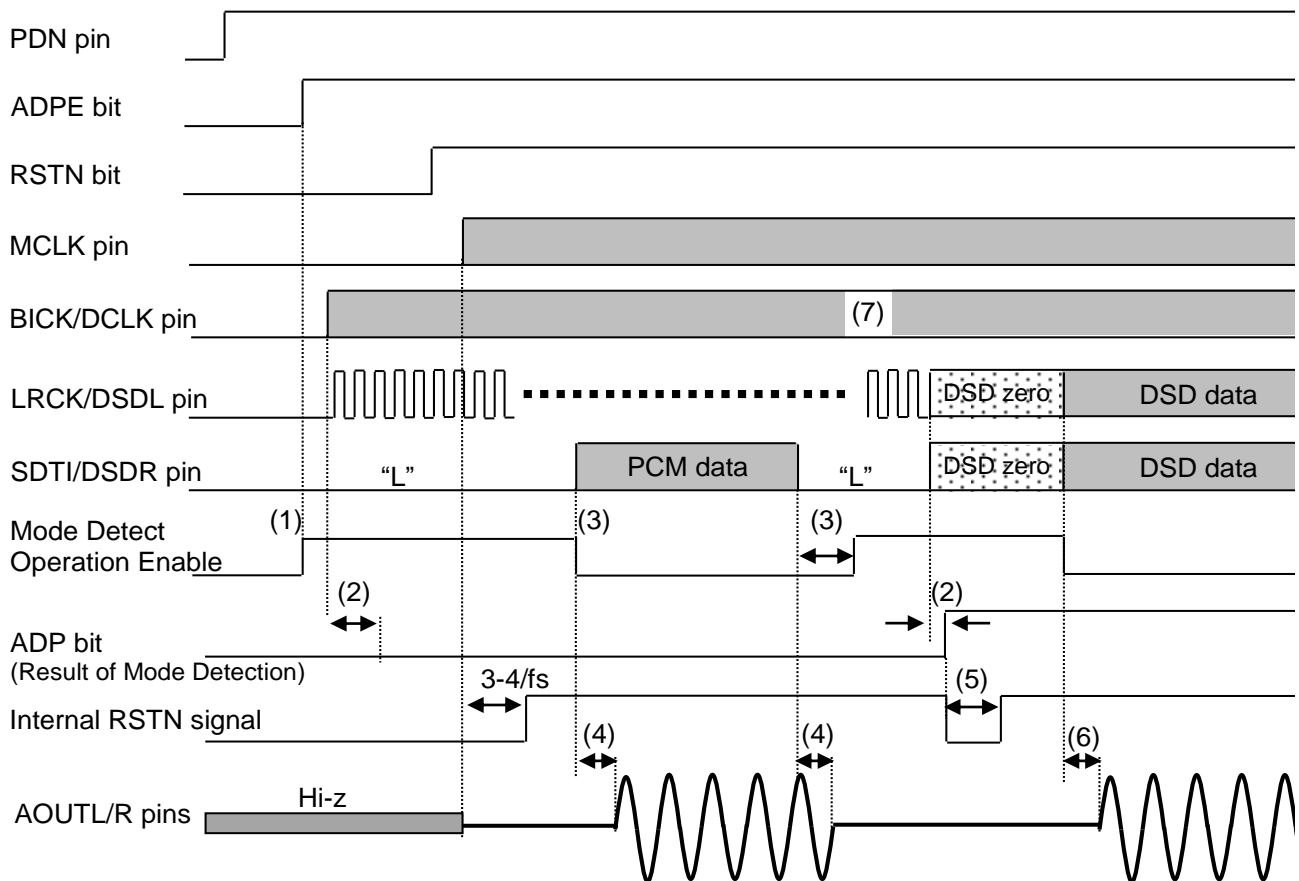

Notes:

- (1) Automatic mode switching between PCM and DSD modes is enabled by setting ADPE bit = "1" after setting PDN pin "L" → "H". If RSTN bit is in default value "0", mode detection operation will start.
- (2) Mode detection is performed by monitoring input signal code pattern of the LRCK/DSDL pin. It is executed for 34 cycles of the BICK/DCLK pin input clock and then ADP bit is changed on a rising edge of input signal of the LRCK/DSDL pin. Mode detection is executed even when there is no MCLK input.
- (3) The AK4462 finishes data mode detection when a data that is not zero is input. Then the AK4462 restarts the mode detection when input data of all channels are continuously zero for the period set by ADPT[1:0] bits.
- (4) In PCM mode, analog output delay time becomes $18/f_s$ longer comparing with when setting ADPE bit = "0".
- (5) When data mode is changed, the AK4462 executes internal reset for $3-4/f_s$ automatically.
- (6) In DSD mode, analog output delay time becomes longer comparing with when setting ADPE bit = "0". In this case, delay time depends on DDMT bit setting.
- (7) A clock input to the BICK/DCLK pin is necessary for data mode detection. The data mode will be maintained if the input clock to the BICK/DCLK pin is stopped.

Figure 56. Changing to DSD mode after Power-up in PCM mode

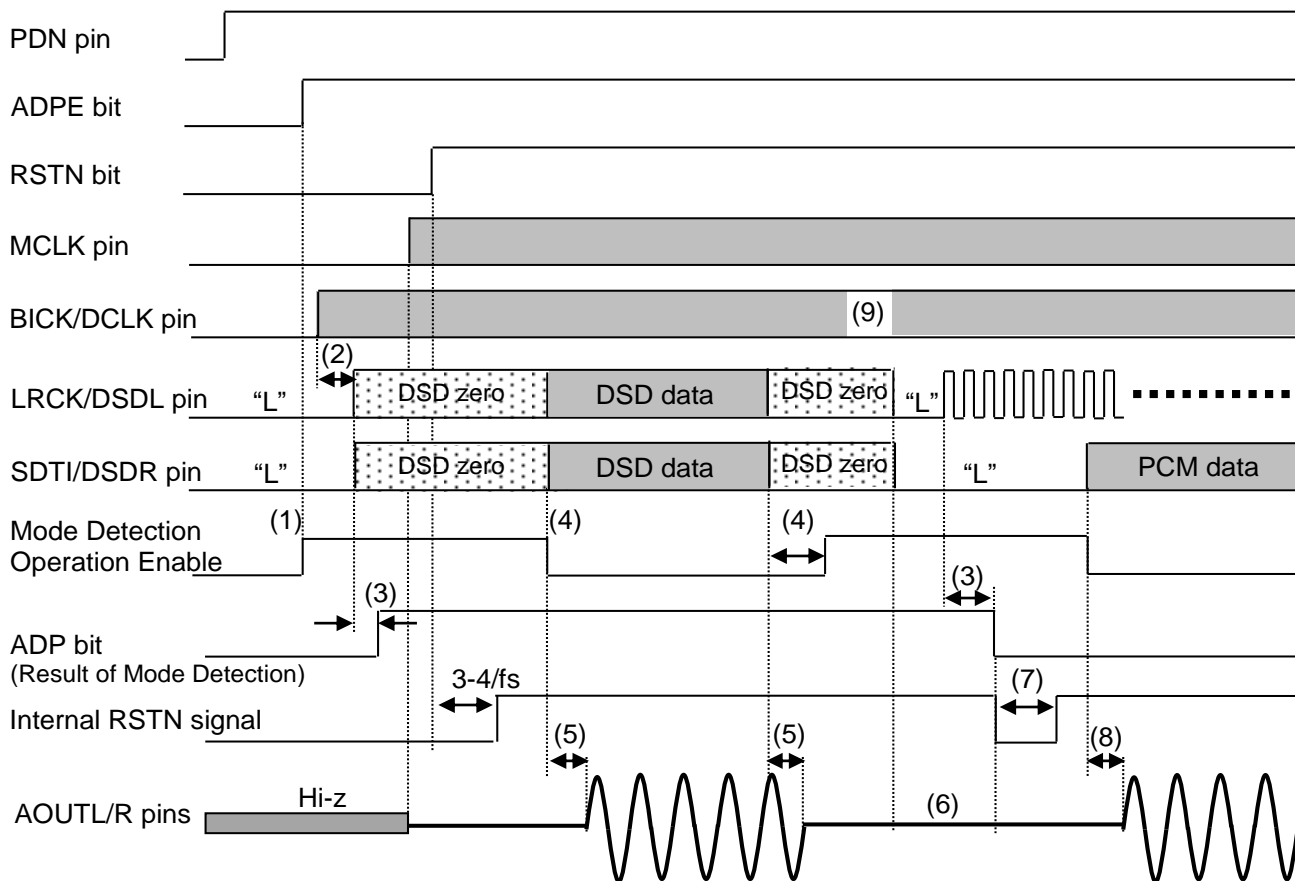

Notes:

- (1) Automatic mode switching between PCM and DSD modes is enabled by setting ADPE bit = "1" after setting the PDN pin "L" → "H". If RSTN bit is in default value "0", mode detection operation will start.
- (2) Upon power up the AK4462, the AK4462 operates in PCM mode if DCLK is input and DSDL is not input.
- (3) Mode detection is performed by monitoring input signal code pattern of the LRCK/DSDL pin. It is executed for 34 cycles of the BICK/DCLK pin input clock and then ADP bit is changed on a rising edge of input signal of the LRCK/DSDL pin. ADP bit outputs "0" in PCM mode and "1" in DSD mode. Mode detection is executed even when there is no MCLK input.
- (4) The AK4462 finishes data mode detection when a data that is not zero is input. Then the AK4462 restarts the mode detection when input data of all channels are continuously zero for the period set by ADPT[1:0] bits.
- (5) In DSD mode, analog output delay time becomes longer comparing with when setting ADPE bit = "0". In this case, delay time depends on DDMT bit setting.
- (6) If DSD data input is stopped in DSD mode, the AK4462 stays in DSD mode and continues operation. In this case, full-scale data is input to the AK4462. Excessive signal output can be avoided by setting DDM bit = "1" enabling automatic mute function works when detecting DSD full-scale input.
- (7) When data mode is changed, the AK4462 executes internal reset for 3–4/fs automatically.
- (8) In PCM mode, analog output delay time becomes 18/fs longer comparing with when setting ADPE bit = "0".
- (9) A clock input to the BICK/DCLK pin is necessary for data mode detection. The data mode will be maintained if the input clock to the BICK/DCLK pin is stopped.

Figure 57. Changing to PCM Mode after Power-up in DSD Mode

9.11. PCM/DoP Automatic Mode Switching Function

The AK4462 has automatic mode switching function that determines PCM or DoP mode from input signal of the SDTI pin. This function is enabled by setting ADOPE bit to “1” while the PDN pin = “H” in register control mode. DOP bit, ADPE bit and DP bit settings are not reflected to the circuit operation if ADOPE bit = “1”. ADOPE bit must be set while PW bit = “0” or RSTN bit = “0”.

Mute function in DSD full-scale detection should be enabled (DDM bit = “1”) to avoid click noise when switching the mode if the automatic switching mode is ON. DDM bit must be set while PW bit = “0” or RSTN bit = “0”.

Group delay in DoP mode becomes larger for 8.5–16.5 LRCK cycles according to DDMT bit setting when ADOPE bit = “1” or DDM bit = “1” (Table 36). Group delay in PCM mode is the same as in PCM manual setting mode (DP bit = ADPE bit = DOP bit = ADOPE bit = “0”).

Mode detection is executed by matching DoP marker and input code of DoP marker slot. The AK4462 detects DoP mode if the input code matches DoP marker for more than 32 LRCK cycles (64 PCM frames) continuously and detects PCM mode if the input code does not match DoP marker even one time. Mode detection is executed even when the AK4462 is reset state (RSTN bit = “0”).

Automatic detection result can be read out by ADOP bit. When ADOPE bit = “1”, ADOP bit will be “0” in PCM mode and “1” in DoP mode. When ADOPE bit = “0”, readout function of ADOP bit is invalid and “0” data is read out.

Figure 58 shows mode switching sequence of PCM and DoP modes by automatic mode switching function.

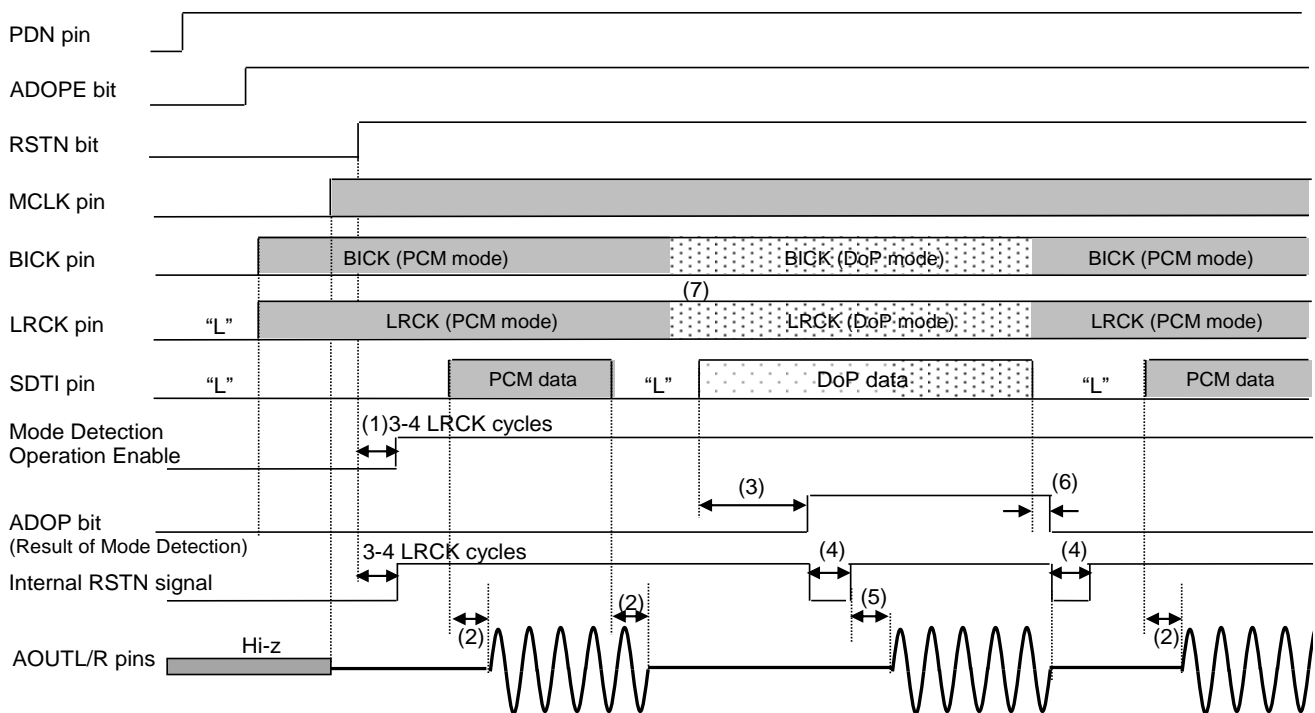

Notes:

- (1) PCM/DoP automatic switching mode is enabled by setting ADOPE bit = "1" after setting the PDN pin to "H" from "L". PCM/DoP mode detection operation starts after 3–4 LRCK cycles from RSTN bit = "1".
- (2) In PCM mode, the delay time which is from data input until analog output is the same as in PCM manual setting mode.
- (3) The AK4462 detects data mode by monitoring DoP marker slot of the SDTI pin input signal. It takes 32 LRCK cycles to detect DoP mode and ADOP bit becomes "1" on a rising edge of the LRCK. Mode detection is valid even if there is no MCLK input.
- (4) When the data mode is switched, the AK4462 is internally reset automatically for 3–4/LRCK cycles.
- (5) In DoP mode, delay time, from data is input until analog output, will be longer than when ADOPE bit = "0". This delay time depends on DDMT bit setting.
- (6) Data mode detection is executed by monitoring the SDTI pin input signal code pattern. It takes 1 LRCK input cycle to detect PCM mode and ADOP bit becomes "0" on a rising edge of the LRCK pin. In this case, AOUTL/R output goes $(VREFH+VREFL)/2$ immediately. Data mode detection is valid even if there is no MCLK input.
- (7) Clock input to the BICK pin and the LRCK pin are necessary for data mode detection. Data mode detection will not be executed and the former operation mode is kept if there is no clock input. When data input is stopped while clocks are supplied, the AK4462 detects PCM mode since DoP marker is not detected.

Figure 58. PCM/DoP Mode Automatic Switching Sequence

9.12. Soft Mute Operation

The soft mute operation is performed at digital domain. When setting the SMUTE pin to “H” or SMUTE bit to “1”, the output signal is attenuated by $-\infty$ during ATT_DATA \times ATT transition time of 1 code shift from the current ATT level. (Refer to Table 33 for ATT)

When setting back the SMUTE pin to “L” or SMUTE bit to “0”, the mute is cancelled and the output attenuation gradually changes to the ATT level during ATT_DATA \times ATT transition time of 1 code shift. If the soft mute is cancelled before attenuating $-\infty$ after starting the operation, the attenuation is discontinued and returned to ATT setting level by the same cycle. The soft mute is effective for changing the signal source without stopping the signal transmission.

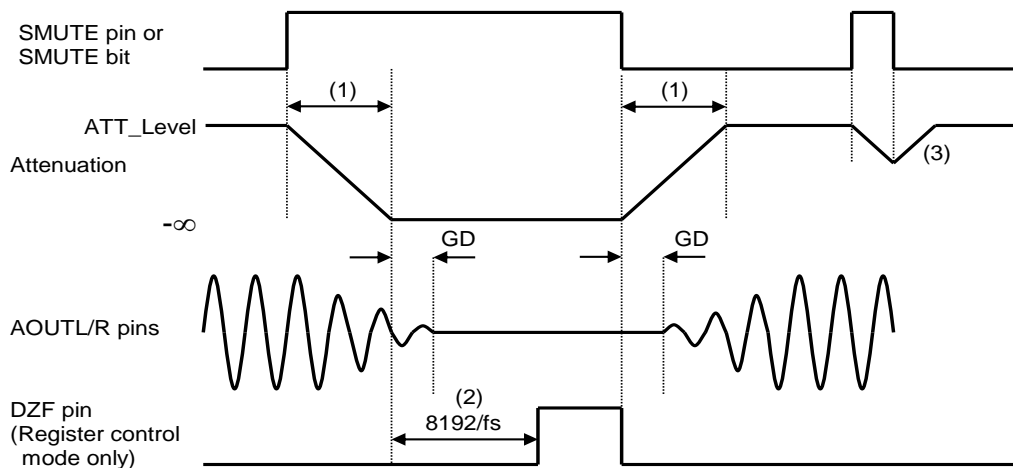

Notes:

- (1) ATT_DATA \times ATT transition time of 1 code shift. For example, this time is 4080/fs when ATT setting value is “FFH” and ATS[1:0] bits = “00”.
- (2) When the input data for set channels (by L bit, R bit) is continuously zeros for a detection time shown in Table 35, the DZF pin goes to “H”. The DZF pin immediately returns to “L” if the input data is not zero.
- (3) If the soft mute is cancelled before attenuating $-\infty$ after starting the operation, the attenuation is discontinued and returned to ATT level by the same cycle.

Figure 59. Soft Mute Function

9.13. LDO

When $TVDD = 3.0\text{--}3.6\text{ V}$, the power for digital core circuit (VDD18) is supplied by the internal LDO by setting the LDOE pin to "H". Table 41 shows the VDD18 pin statuses with the PDN and LDOE pins setting. The internal LDO is powered up by setting the PDN pin from "L" to "H" (power down release) and it starts supplying 1.8 V to the VDD18 pin. Connect a $1\ \mu\text{F}$ ($\pm 50\%$) capacitor to the VDD18 pin when using the LDO. To ensure reliable operation of the internal LDO, do not deviate more than $\pm 50\%$ from the recommended capacitor value. It takes 2 ms (Max.) to power-up the internal LDO.

Table 41. LDO select mode (x: do not care)

| PDN | LDOE | TVDD | VDD18 |
|-----|------|-----------|---|
| x | L | 1.7–3.6 V | LDO OFF: Supply 1.7–1.98 V to VDD18. |
| L | H | 3.0–3.6 V | 500 Ω Pull-down |
| H | H | 3.0–3.6 V | LDO ON: LDO outputs 1.8 V (Do not connect with other device loads) |

The AK4462 has error detect function, as shown in Table 42 for LDO operation (LDOE pin = "H"). The internal LDO will be powered down and stop supplying the power to the digital core when an error is detected. In this case, the analog signal output and the SDA pin becomes Hi-Z state (In I²C-Bus control mode, ACK is not output). The AK4462 must be reset by setting the PDN pin = "L" → "H" to recover from the error detection status.

Table 42. LDO Error Detection

| No | Error Detection | Error Detection Condition |
|----|---------------------------|---|
| 1 | LDO Overvoltage Detection | The AK4462 detects an error when the output voltage of the LDO pin exceeds overvoltage threshold. Threshold: 2.35 V (Typ.) |
| 2 | LDO Overcurrent Detection | The AK4462 detects an error when the current flows from LDO output exceeds overcurrent threshold. Threshold: 108 mA (Typ.) |

9.14. Power Up/Down Sequence

The AK4462 is powered down when the PDN pin is “L”. In power down state, all circuits stop operation and initialized, and the analog output becomes floating (Hi-Z) state. The PDN pin must held “L” for more than 150 ns for a certain reset after all power supplies are on. There is a possibility of malfunctions with the “L” pulse less than 150 ns. Power down is released by setting the PDN pin to “H” from “L”. In this time LDO (if LDOE pin = “H”) are powered up and the analog output becomes floating (Hi-Z) state until all clocks are input.

9.14.1. Pin Control Mode (PS pin = “H” and I2C pin = “H”)

All circuits will be powered up by inputting MCLK, LRCK and BICK clocks after the PDN pin = “H”. Figure 60 shows system timing example of power down/up when using the internal LDO (LDOE pin = “H”).

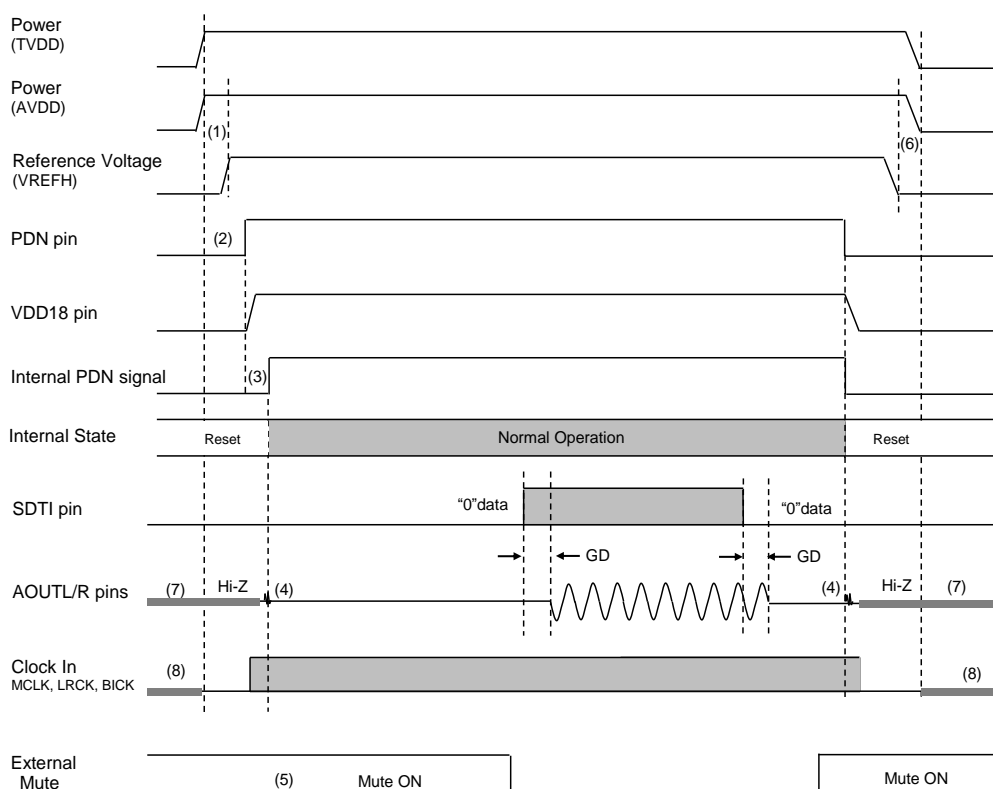

Notes:

- (1) VREFH reference voltage should be input after AVDD is powered up or at the same time. Power up sequence between AVDD and TVDD are not critical.
- (2) The PDN pin must be “L” when start supplying AVDD and TVDD. It must be held “L” for more than 150 ns after AVDD and TVDD are powered up.
- (3) VDD18 output voltage (generated by Internal LDO) is powered up by setting the PDN pin = “H” if the LDOE pin = “H”. The internal PDN signal will rise in 2 ms (Max.) after the PDN pin = “H” and the internal circuit will start operation.
- (4) Click noise occurs on an edge of PDN signal. This noise is output even if “0” data is input.
- (5) Mute the analog output externally if click noise (4) adversely affect system performance.
- (6) VREFH reference voltage should be stopped before AVDD is powered down or at the same time. Power down sequence between AVDD and TVDD are not critical.
- (7) Analog outputs are floating (Hi-Z) in power down state.
- (8) Do not input clocks (MCLK, BICK and LRCK) until after TVDD is turned on.

Figure 60. Power-up/down sequence example (Pin Control Mode, LDOE pin = “H”)

The timing example when not using the internal LDO (LDOE pin = "L") is shown in Figure 61.

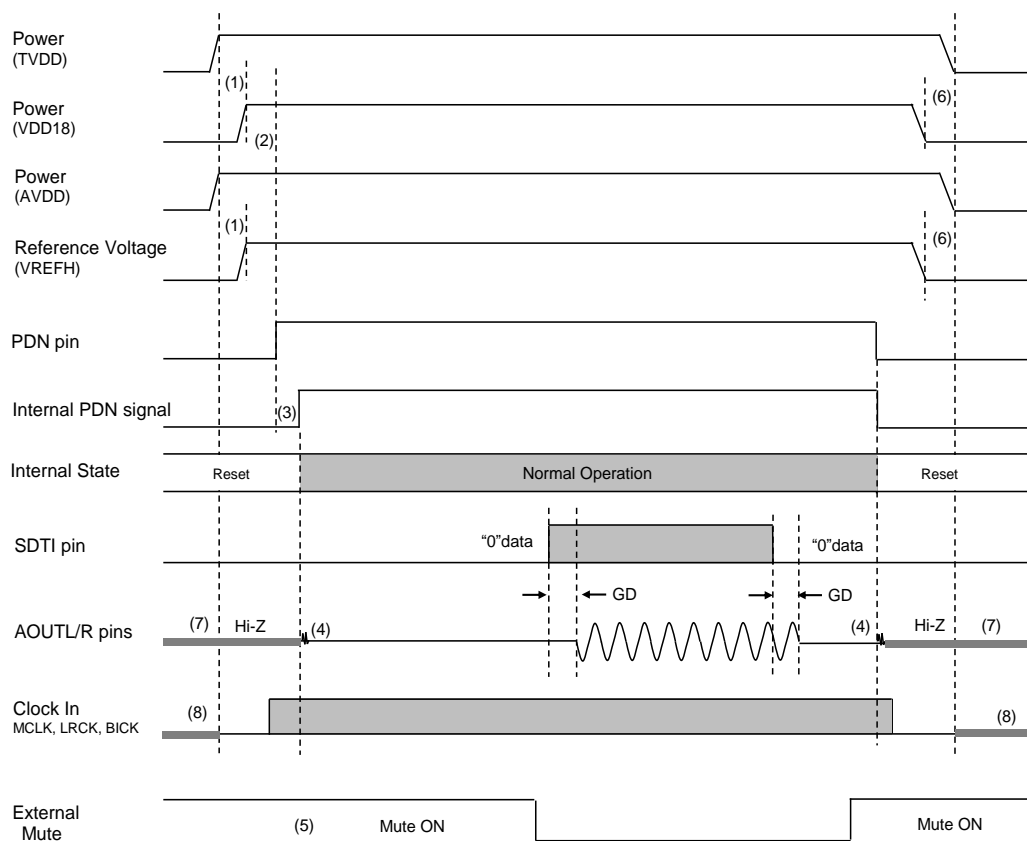

Notes:

- (1) TVDD must be powered up before VDD18 is powered up or at the same time. Power up sequence between AVDD and TVDD, AVDD and VDD18 are not critical. VREFH reference voltage should be input after AVDD is powered up or at the same time.
- (2) The PDN pin must be "L" when start supplying AVDD, TVDD and VDD18. It must be held "L" for more than 150 ns after AVDD, TVDD and VDD18 are powered up.
- (3) When the LDOE pin = "L", the internal PDN signal is on in 1 μ s (Max.) after the PDN pin is set to "H", and the internal circuit will start operation.
- (4) Click noise occurs on an edge of PDN signal. This noise is output even if "0" data is input.
- (5) Mute the analog output externally if click noise (4) adversely affect system performance.
- (6) TVDD must be powered down after or at the same time of VDD18. Power down sequence between AVDD and TVDD, AVDD and VDD18 are not critical. VREFH reference voltage should be stopped before AVDD is powered down or at the same time.
- (7) Analog outputs are floating (Hi-Z) in power down state.
- (8) Do not input clocks (MCLK, BICK and LRCK) until after TVDD is turned on.

Figure 61. Power-up/down sequence example (Pin Control Mode, LDOE pin = "L")

9.14.2. Register Control Mode (PS pin = “L” and I2C pin = “H”, or I2C pin = “L”)

Figure 62 shows system timing example of power down/up when using the internal LDO (LDOE pin = “H”). Register access becomes available and internal LDO is powered up after setting the PDN pin = “H”. The analog circuit starts operation by supplying necessary clocks (MCLK, LRCK and BICK for PCM mode, MCLK and DCLK for DSD mode). In this time, the analog output pins output analog common voltage ($VREFH+VREFL$)/2. Then the AK4462 transitions to normal operation by setting RSTN bit = “1”.

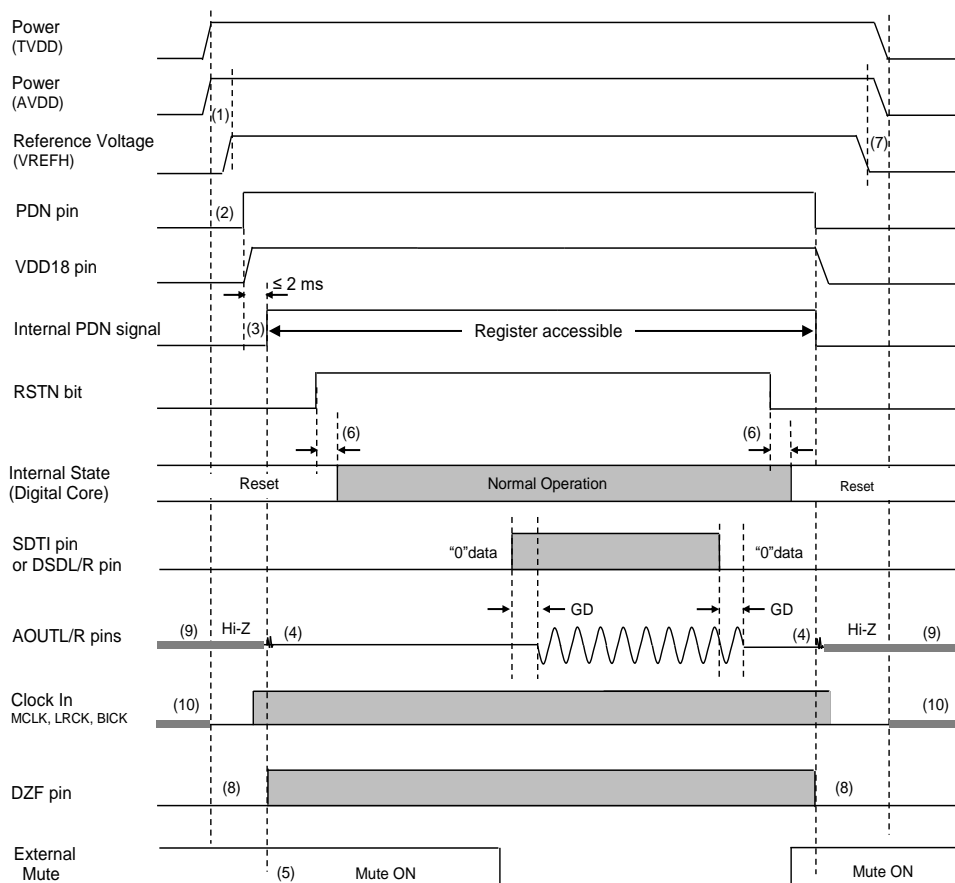

Notes:

- (1) VREFH reference voltage should be input after AVDD is powered up or at the same time. Power up sequence between AVDD and TVDD are not critical.
- (2) The PDN pin must be “L” when start supplying AVDD and TVDD. It must be held “L” for more than 150 ns after AVDD and TVDD are powered up.
- (3) VDD18 output voltage (generated by Internal LDO) is powered up by setting the PDN pin = “H” if the LDOE pin = “H”. The internal PDN signal will rise in 2 ms (Max.) after the PDN pin = “H” and control register access becomes available.
- (4) Click noise occurs on an edge of PDN signal. This noise is output even if “0” data is input.
- (5) Mute the analog output externally if click noise (4) adversely affect system performance.
- (6) It takes $3-4/f_s$ until a reset instruction is valid when writing “0” to RSTN bit and it takes $3-4/f_s$ when releasing the reset.
- (7) VREFH reference voltage should be stopped before AVDD is powered down or at the same time. Power down sequence between AVDD and TVDD are not critical.
- (8) The DZF pin outputs “L” in power down state.
- (9) Analog outputs are floating (Hi-Z) in power down state.
- (10) Do not input clocks (MCLK, BICK and LRCK) until after TVDD is turned on.

Figure 62. Power-up/down sequence example (Register Control Mode, LDOE pin = “H”)

The system timing example of power up/down when not using LDO (LODE pin = "L") is shown in Figure 63.

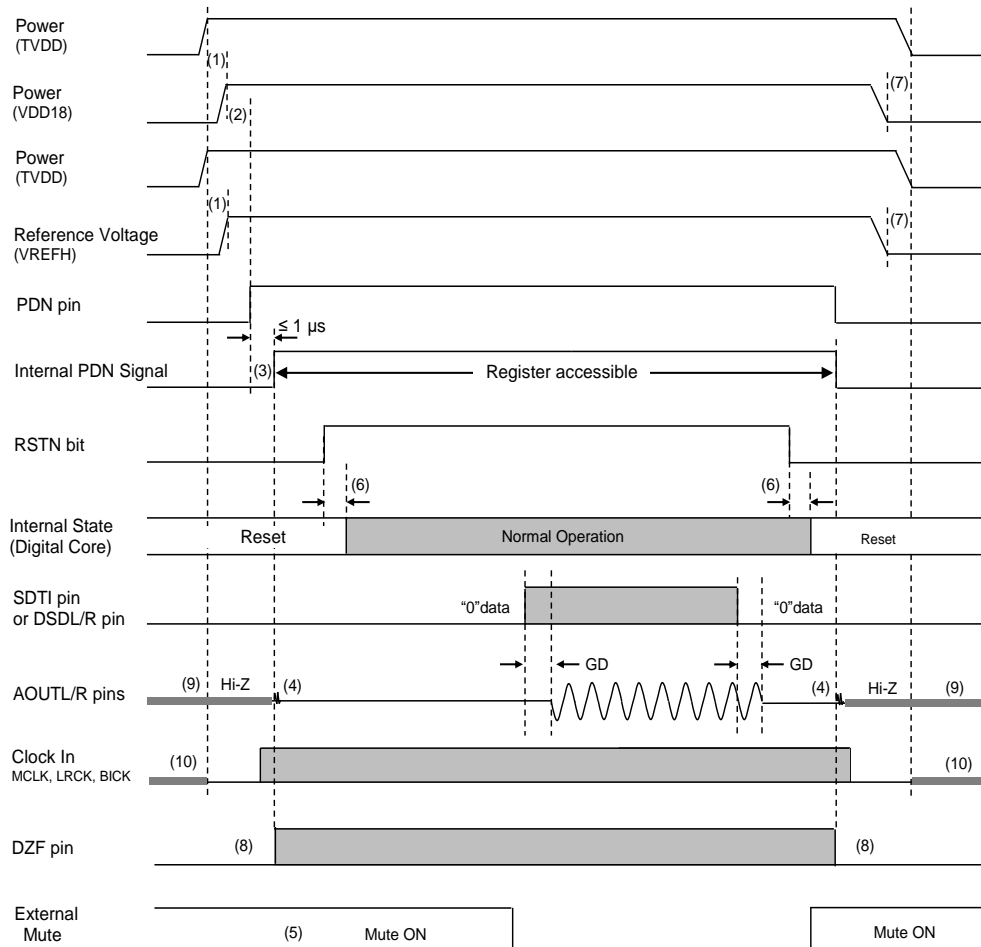

Notes:

- (1) TVDD must be powered up before VDD18 is powered up or at the same time. Power up sequence between AVDD and TVDD, AVDD and VDD18 are not critical. VREFH reference voltage should be input after AVDD is powered up or at the same time.
- (2) The PDN pin must be "L" when start supplying AVDD, TVDD and VDD18. It must be held "L" for more than 150 ns after AVDD, TVDD and VDD18 are powered up.
- (3) When the LDOE pin = "L", the internal PDN signal is on in 1 μs (Max.) after the PDN pin is set to "H", and control register access becomes available.
- (4) Click noise occurs on an edge of PDN signal. This noise is output even if "0" data is input.
- (5) Mute the analog output externally if click noise (4) adversely affect system performance.
- (6) It takes $3-4/f_s$ until a reset instruction is valid when writing "0" to RSTN bit and it takes $3-4/f_s$ when releasing the reset.
- (7) TVDD must be powered down after or at the same time of VDD18. Power down sequence between AVDD and TVDD, AVDD and VDD18 are not critical. VREFH reference voltage should be stopped before AVDD is powered down or at the same time.
- (8) The DZF pin outputs "L" in power down state.
- (9) Analog outputs are floating (Hi-Z) in power down state.
- (10) Do not input clocks (MCLK, BICK and LRCK) until after TVDD is turned on.

Figure 63. Power-up/down sequence example (Register Control Mode, LDOE pin = "L")

9.15. Power Down, Standby and Reset Function

Power Down, Standby and Reset functions of the AK4462 are controlled by PDN pin, PW bit, MCLK and RSTN bit (Table 43).

Table 43. Power Down, Standby, & Reset function (x: do not care)

| State | PDN pin | MCLK Input | PW bit | RSTN bit | DIGITAL Block | ANALOG Block | LDO / Register | Analog Output |
|------------------|---------|------------|--------|----------|---------------|--------------|----------------|---------------------|
| Power Down | L | x | x | x | OFF | OFF | OFF | Hi-Z |
| Standby | H | No | x | x | OFF | OFF | ON | Hi-Z |
| | H | Yes | 0 | x | OFF | OFF | ON | Hi-Z |
| Reset | H | Yes | 1 | 0 | OFF | ON | ON | $(VREFH + VREFL)/2$ |
| Normal Operation | H | Yes | 1 | 1 | ON | ON | ON | Signal output |

9.15.1. Standby Sequence by MCLK

The AK4462 detects a clock stop and all circuits except MCLK stop detection circuit, control register and LDO (only when the LDOE pin = "H") stop operation if MCLK is not input for 1 μ s (Min.) during operation (PDN pin = "H"). In this case, the analog output goes floating state (Hi-Z). The AK4462 returns to normal operation if PW bit and RSTN bit are "1" after starting to supply MCLK again. The zero detection function is disabled when MCLK is stopped. Figure 64 shows standby sequence by MCLK.

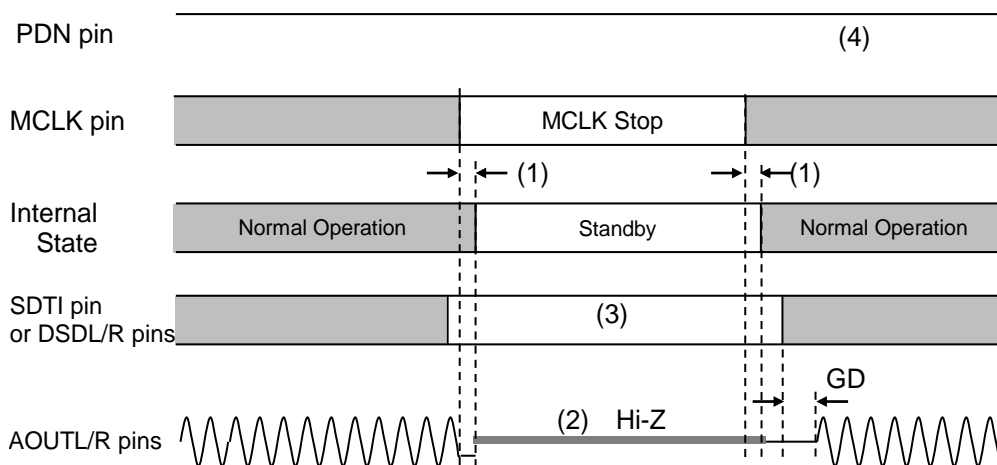

Notes:

- (1) The AK4462 detects MCLK stop and becomes standby state when MCLK edge is not detected for 1 μ s (Min.) during operation.
- (2) The analog output goes to floating state (Hi-Z) in standby state.
- (3) Click noise can be reduced by inputting "0" data when stopping and resuming MCLK supply.
- (4) Resume MCLK input to release the standby state by MCLK. In this case, power-up sequence by the PDN pin is not necessary.

Figure 64. Standby Sequence by MCLK

9.15.2. Standby Sequence by PW bit

All circuits except control register and LDO (only when the LDOE pin = "H") stop operation by setting PW bit to "0". In this case, control register access is available. The analog output goes to floating state (Hi-Z). Figure 65 shows standby sequence by PW bit.

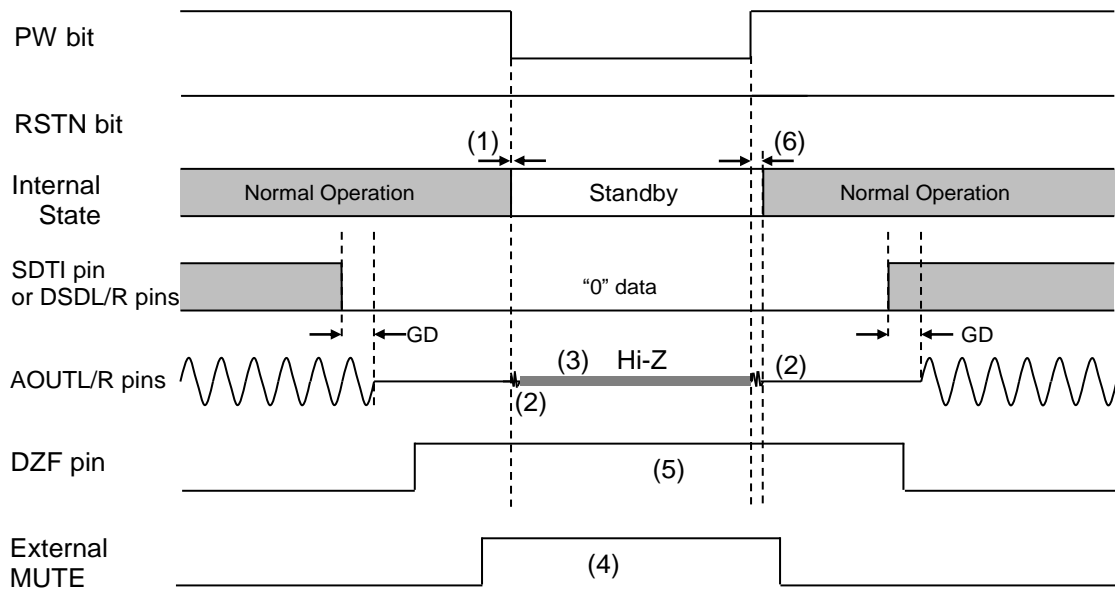

Notes:

- (1) The corresponding channels become standby state immediately when writing "0" to PW bit.
- (2) Click noise occurs on an edge of PW bit ("↓↑"). This noise is output even if "0" data is input.
- (3) The analog output is floating (Hi-Z) state when PW bit = "0".
- (4) Mute the analog output externally if click noise (2) or Hi-Z output (3) adversely affect system performance.
- (5) The output of the DZF pin holds last value in standby state by PW bit = "0". This figure shows the sequence when L bit = R bit = "1", DZFB bit = "0" and DDMOE bit = "0".
- (6) It takes 2–3/fs until standby state is released when writing "1" to PW bit.

Figure 65. Standby Sequence by PW bit (Register Control Mode)

9.15.3. Reset by RSTN bit

Digital circuits except control registers and clock divider are reset by setting RSTN bit to "0". In this case, control register settings are held, the analog output becomes $(V_{REFH}+V_{REFL})/2$ V and the DZF pin outputs "H" (refer to [9.8.1 Zero Detection](#) for details). [Figure 66](#) shows reset sequence by RSTN bit.

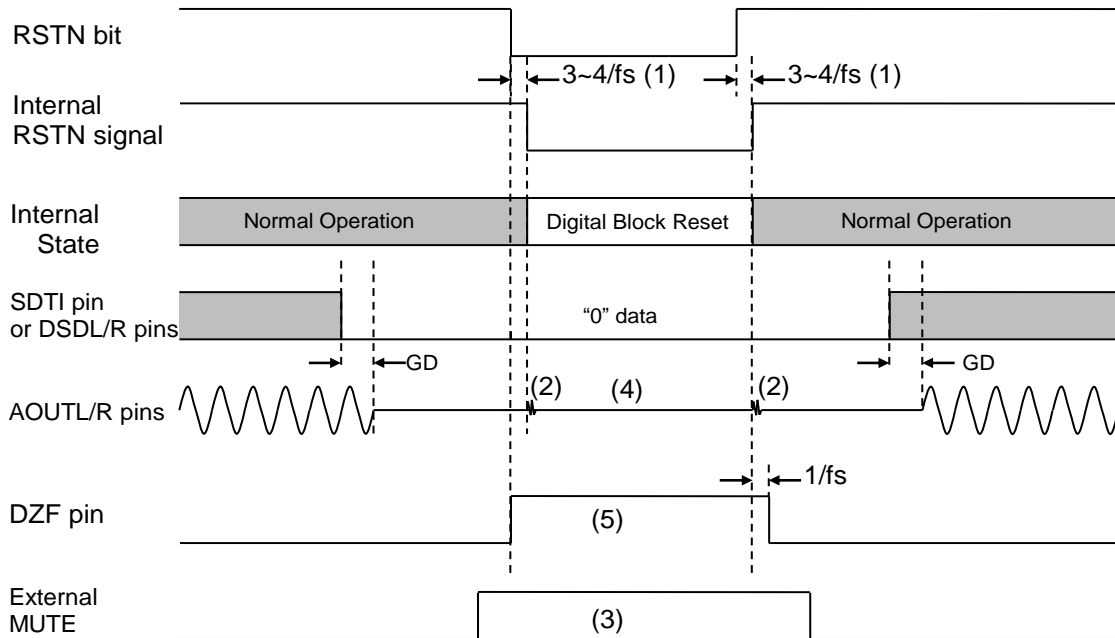

Notes:

- (1) It takes $3-4/f_s$ until a reset instruction is valid when changing RSTN bit to "0" and it takes $3-4/f_s$ when releasing the reset.
- (2) Click noise occurs on an edge of internal RSTN signal. This noise is output even if "0" data is input.
- (3) Mute the analog output externally if click noise (2) adversely affect system performance.
- (4) The analog output is $(V_{REFH}+V_{REFL})/2$ V when RSTN bit = "0".
- (5) This figure shows the sequence when DZFB bit = "0", DDMOE bit = "0" and either L bit or R bit is "1". The DZF pin goes "H" on a falling edge of RSTN bit and goes "L" $1/f_s$ after a rising edge of internal RSTN bit.

Figure 66. Reset Timing Example (Register Control Mode)

9.16. Synchronize Function (PCM mode, DoP mode)

The AK4462 has a synchronize function. With this synchronize function, group delays between each device can be kept within $4/256 f_s$ when using multiple AK4462's.

Clock synchronize function becomes valid when input data of all channels are "0" for 8192 times continuously in PCM mode, when all channels data become "0" and kept for 8192 times continuously by attenuation, or when RSTN bit = "0". In PCM mode, the internal counter is synchronized with a rising edge of LRCK (falling edge of LRCK when the data format is I²S compatible). In this case, the analog output becomes $(VREFH+VREFL)/2$ V.

This function is disabled by setting SYNCE bit = "0" in register control mode. Figure 67 shows a synchronizing sequence when the input data is "0" for 8192 times continuously. Figure 68 shows a synchronizing sequence by RSTN bit.

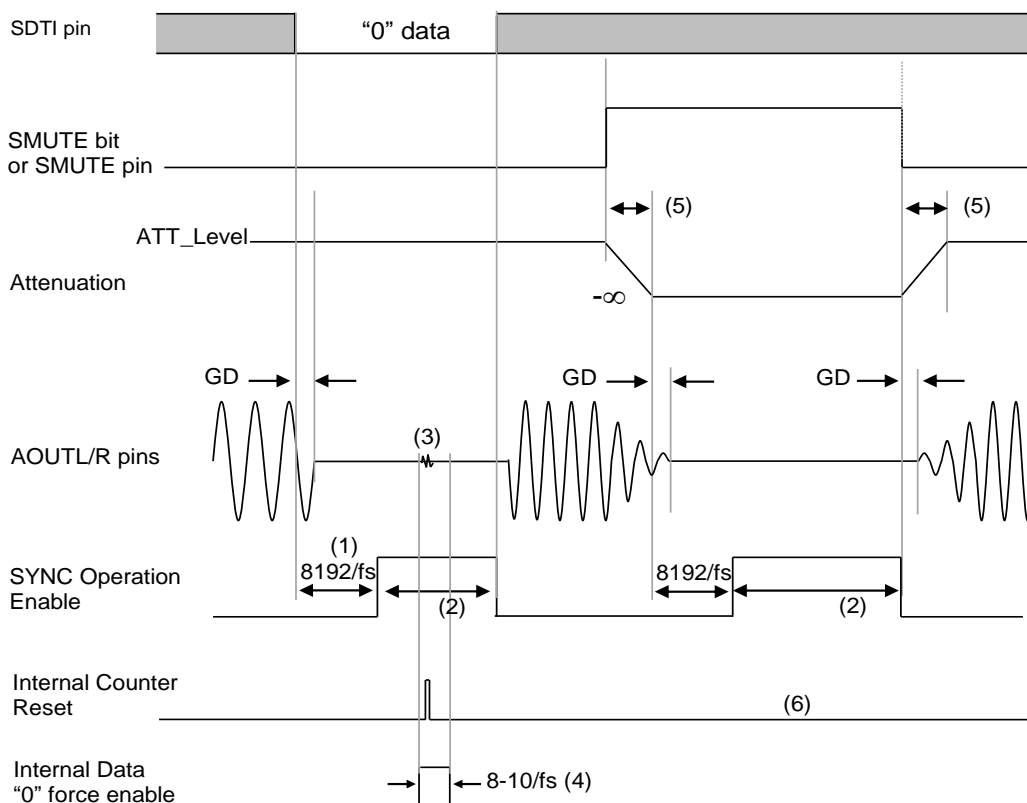

Notes:

- (1) When all channels data are "0" for 8192 times continuously, the synchronize function is enabled.
- (2) To ensure the synchronization, zero data input should be kept for 500 μ s at least after the synchronize function is enabled.
- (3) Input data of $\Delta\Sigma$ Modulator is fixed to "0" forcibly for 8–10/ f_s when internal counter is reset.
- (4) Click noise may occur when the internal counter is reset. This noise is output even if "0" data is input. Mute the analog output externally if this click noise affects the system performance.
- (5) Refer to "9.7 Digital Attenuation" for ATT transition time.
- (6) When the internal clock and external input clock are in synchronization, the internal counter is not reset even if the synchronize function is valid.

Figure 67. Synchronization Sequence by Continuous "0" Data Input for 8192 Times

If RSTN bit is set to "0", digital circuit is reset in $3\text{--}4/f_s$ and the synchronization function becomes valid.

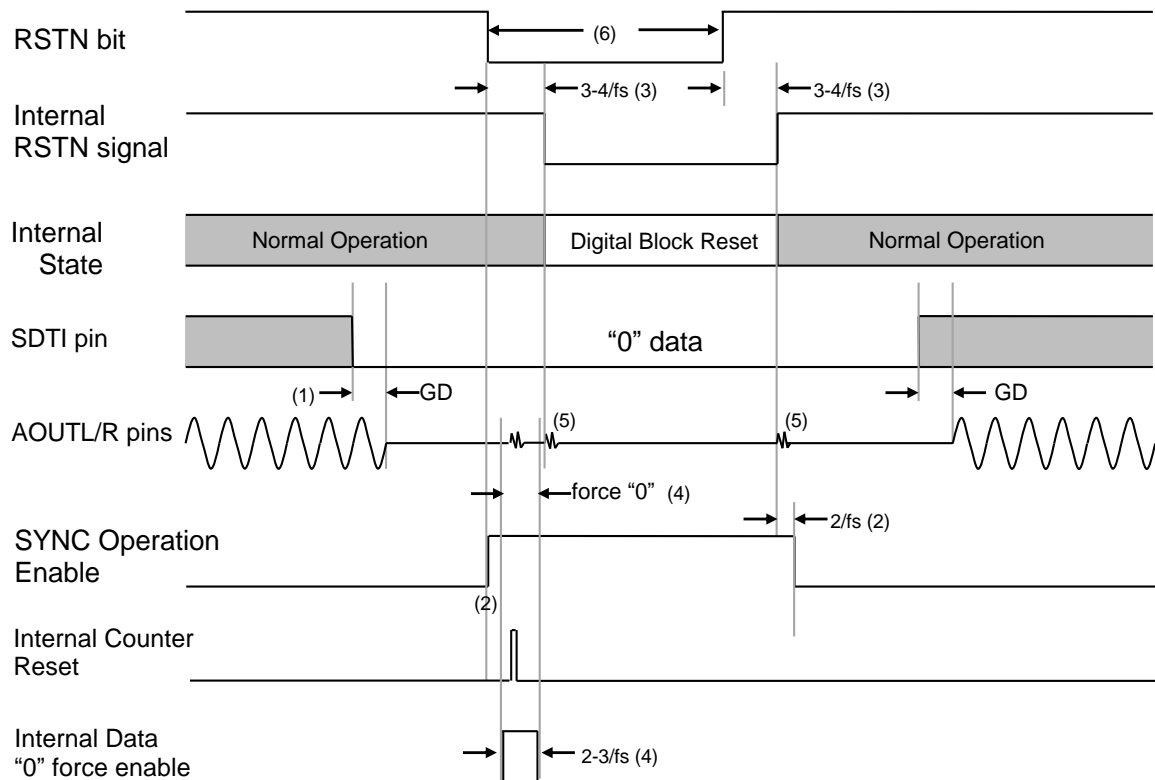

Notes:

- (1) Since the analog output corresponding to digital input has group delay (GD), it is recommended to have a no-input period longer than the group delay before writing "0" to RSTN bit.
- (2) The synchronization function becomes valid on a falling edge of RSTN bit. It takes $2\text{--}3/f_s$ to become invalid after the internal RSTN is changed when changing RSTN bit to "1".
- (3) It takes $3\text{--}4/f_s$ until the internal RSTN is changed when changing RSTN bit to "0" and it takes $3\text{--}4/f_s$ when changing RSTN bit to "1". The synchronization function becomes valid immediately when writing "0" to RSTN bit. Therefore, there is a case that the internal counter is reset before internal RSTN signal of the LSI is changed.
- (4) Input data of $\Delta\Sigma$ Modulator is fixed to "0" forcibly for $2\text{--}3/f_s$ when the internal counter is reset.
- (5) Click noise occurs on rising and falling edges of the internal RSTN signal and when the internal counter is reset. This noise is output even if "0" data is input. Mute the analog output externally if this click noise affects the system performance.
- (6) To ensure the synchronization, reset state should be kept for $500\ \mu\text{s}$ at least after the synchronize function is enabled.

Figure 68. Synchronization Sequence by RSTN bit (Register Control Mode)

9.17. Register Control Interface

9.17.1. 3-wire Serial Control Mode (I2C pin = "L")

Internal registers may be written to through 3-wire μ P interface pins: CSN, CCLK and CDTI. The data on this interface consists of Chip address (2 bits, C1/0), Read/Write (1 bit; fixed to "1", write only), Register address (MSB first, 5 bits) and Control data (MSB first, 8 bits). The data is output on a falling edge of CCLK and the data is received on a rising edge of CCLK. The writing of data is valid when CSN "↑". The clock speed of CCLK is 5 MHz (Max.).

Setting the PDN pin to "L" resets the registers to their default values. In register control mode, the digital block except control registers and clock divider is reset by setting RSTN bit to "0". In this case, the register values are not initialized.

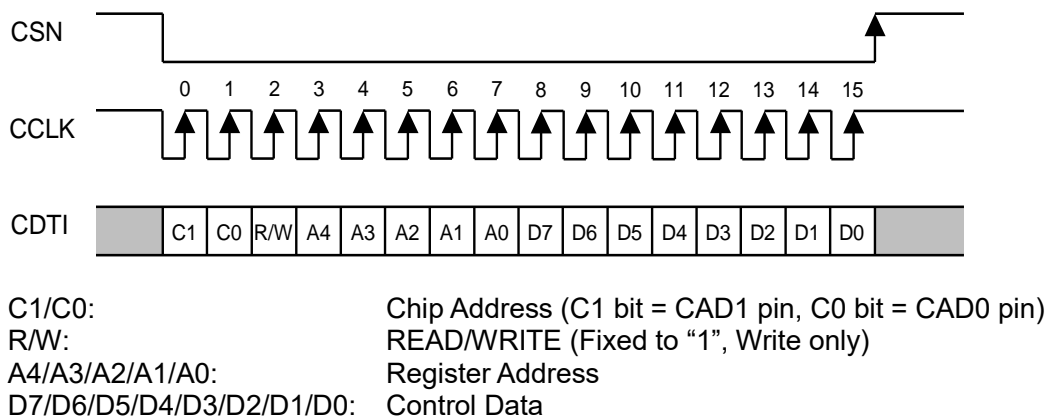

Figure 69. Control I/F Timing

Notes:

- (1) The AK4462 does not support read commands in 3-wire serial control mode.
- (2) When the PDN pin = "L", writing into control registers is prohibited.
- (3) The control data cannot be written when the CCLK rising edge is 15 times or less, or 17 times or more during CSN is "L".

9.17.2. I²C-Bus Control Mode (I2C pin = “H”, PS pin = “L”)

The AK4462 supports the fast-mode I²C-Bus (Max.: 400 kHz, Ver. 1.0).

9.17.2.1. WRITE Operation

Figure 70 shows the data transfer sequence for the I²C-Bus control mode. All commands are preceded by a START condition. A HIGH to LOW transition on the SDA line while SCL is HIGH indicates a START condition (Figure 76). After the START condition, a slave address is sent. This address is 7 bits long followed by the eighth bit that is a data direction bit (R/W). The most significant five bits of the slave address are fixed as “00100”. The next bits are CAD1 and CAD0 (device address bits). This bit identifies the specific device on the bus. The hard-wired input pin (CAD1 pin, CAD0_I2C pin) sets these device address bits ((CAD1, CAD0 are set by pin

Figure 71). If the slave address matches that of the AK4462, the AK4462 generates an acknowledge and the operation is executed. The master must generate the acknowledge-related clock pulse and release the SDA line (HIGH) during the acknowledge clock pulse (Figure 77). A R/W bit value of “1” indicates that the read operation is to be executed, and “0” indicates that the write operation is to be executed.

The second byte consists of the control register address of the AK4462 and the format is MSB first. The most significant three bits are fixed as “000” (Figure 72). The data after the second byte contains control data. The format is MSB first, 8bits (Figure 73). The AK4462 generates an acknowledge after each byte is received. Data transfer is always terminated by a STOP condition generated by the master. A LOW to HIGH transition on the SDA line while SCL is HIGH defines a STOP condition (Figure 76).

The AK4462 can perform more than one byte write operation per sequence. After receipt of the third byte the AK4462 generates an acknowledge and awaits the next data. The master can transmit more than one byte instead of terminating the write cycle after the first data byte is transferred. After receiving each data packet the internal address counter is incremented by one, and the next data is automatically taken into the next address. If the address exceeds “15H” prior to generating a stop condition, the address counter will “roll over” to “00H” and the previous data will be overwritten.

The data on the SDA line must remain stable during the HIGH period of the clock. HIGH or LOW state of the data line can only be changed when the clock signal on the SCL line is LOW (Figure 78) except for the START and STOP conditions.

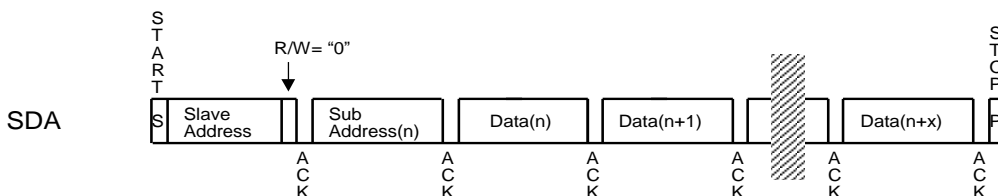

Figure 70. Data Transfer Sequence in I²C-Bus control mode

| | | | | | | | |
|---|---|---|---|---|------|------|-----|
| 0 | 0 | 1 | 0 | 0 | CAD1 | CAD0 | R/W |
|---|---|---|---|---|------|------|-----|

(CAD1, CAD0 are set by pin)

Figure 71. The First Byte

| | | | | | | | |
|---|---|---|----|----|----|----|----|
| 0 | 0 | 0 | A4 | A3 | A2 | A1 | A0 |
|---|---|---|----|----|----|----|----|

Figure 72. The Second Byte

| | | | | | | | |
|----|----|----|----|----|----|----|----|
| D7 | D6 | D5 | D4 | D3 | D2 | D1 | D0 |
|----|----|----|----|----|----|----|----|

Figure 73. Byte Structure after The Second Byte

9.17.2.2. READ Operation

Set the R/W bit = "1" for the READ operation of the AK4462. After transmission of data, the master can read the next address's data by generating an acknowledge instead of terminating the write cycle after the receipt of the first data word. After receiving each data packet the internal address counter is incremented by one, and the next data is automatically taken into the next address. If the address exceeds "15H" prior to generating stop condition, the address counter will "roll over" to "00H" and the data of "00H" will be read out.

The AK4462 supports two basic read operations: Current Address Read and Random Address Read.

9.17.2.2.1. Current Address Read

The AK4462 has an internal address counter that maintains the address of the last accessed word incremented by one. Therefore, if the last access (either a read or write) were to address "n", the next CURRENT READ operation would access data from the address "n+1". After receipt of the slave address with R/W bit "1", the AK4462 generates an acknowledge, transmits 1-byte of data to the address set by the internal address counter and increments the internal address counter by 1. If the master does not generate an acknowledge but generates a stop condition instead, the AK4462 ceases the transmission.

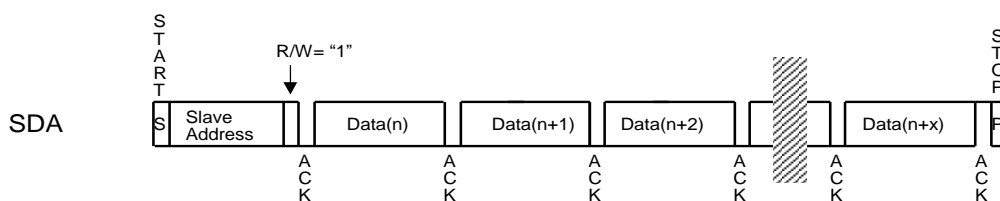

Figure 74. Current Address Read

9.17.2.2.2. Random Address Read

The random read operation allows the master to access any memory location at random. Prior to issuing the slave address with the R/W bit "1", the master must first perform a "dummy" write operation. The master issues a start request, a slave address (R/W bit = "0") and then the register address to read. After the register address is acknowledged, the master immediately reissues the start request and the slave address with the R/W bit "1". The AK4462 then generates an acknowledge, 1 byte of data and increments the internal address counter by 1. If the master does not generate an acknowledge but generates a stop condition instead, the AK4462 ceases the transmission.

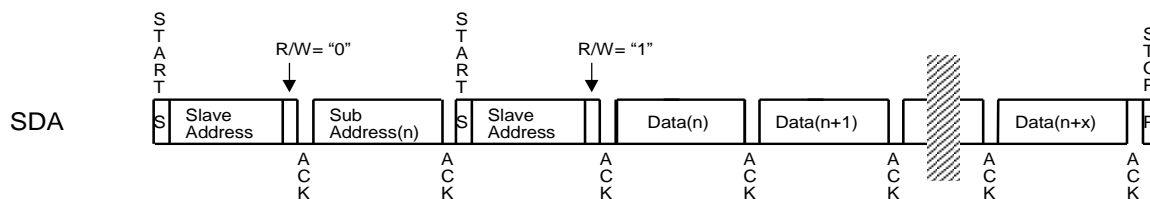

Figure 75. Random Address Read

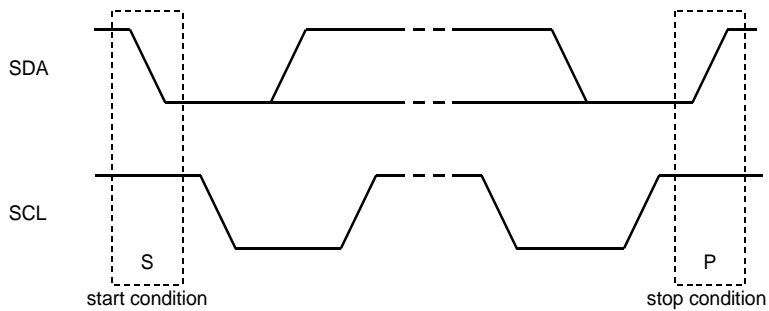

Figure 76. Start Condition and Stop Condition

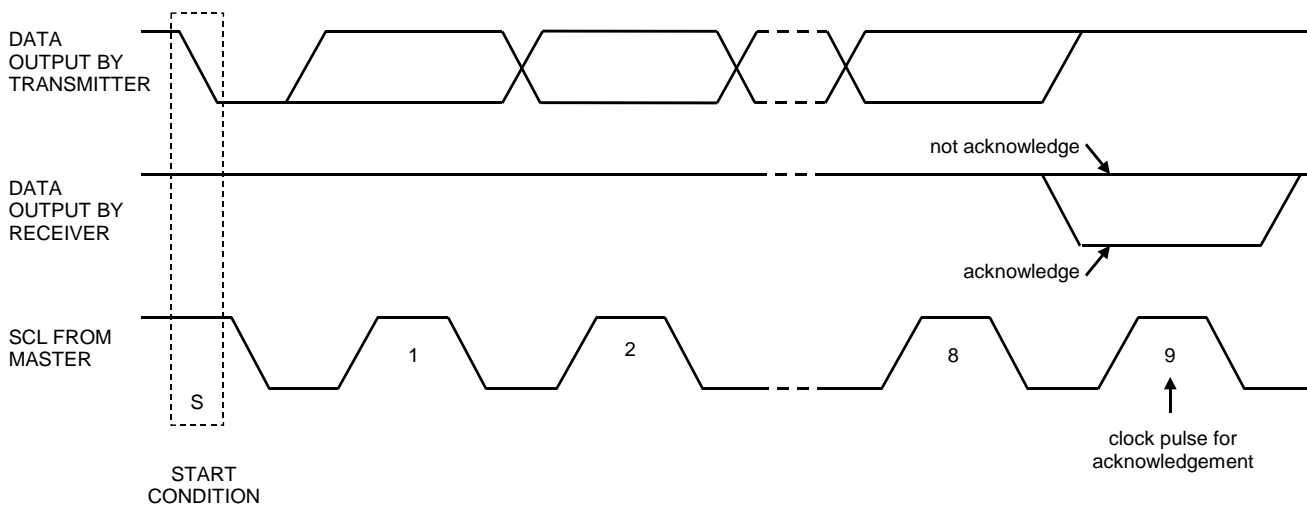

Figure 77. Acknowledge (I²C-Bus)

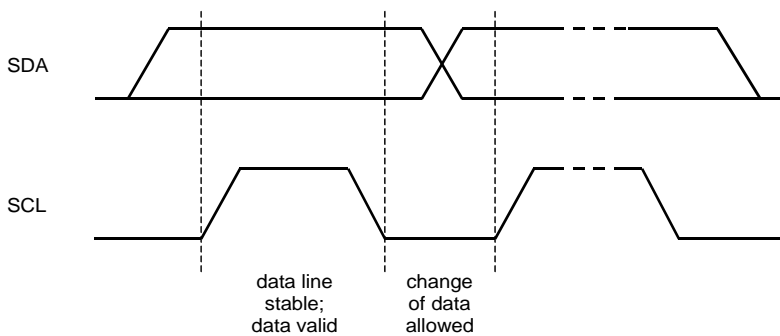

Figure 78. Bit Transfer (I²C-Bus)

9.18. Register Map

| Addr | Register Name | D7 | D6 | D5 | D4 | D3 | D2 | D1 | D0 | default |
|------|---------------|-----------|-----------|---------|---------|---------|---------|---------|-----------|---------|
| 00H | Control 1 | ACKS | 0 | 0 | 0 | DIF[2] | DIF[1] | DIF[0] | RSTN | 0CH |
| 01H | Control 2 | 0 | 0 | SD | DFS[1] | DFS[0] | DEM[1] | DEM[0] | SMUTE | 22H |
| 02H | Control 3 | DP | ADP | DCKS | DCKB | MONO | DZFB | SELLR | SLOW | 00H |
| 03H | Lch ATT | ATTL[7] | ATTL[6] | ATTL[5] | ATTL[4] | ATTL[3] | ATTL[2] | ATTL[1] | ATTL[0] | FFH |
| 04H | Rch ATT | ATTR[7] | ATTR[6] | ATTR[5] | ATTR[4] | ATTR[3] | ATTR[2] | ATTR[1] | ATTR[0] | FFH |
| 05H | Control 4 | INVL | INVR | 0 | 0 | 0 | 0 | DFS[2] | SSLOW | 00H |
| 06H | DSD1 | DDM | DML | DMR | DDMOE | 0 | DDMT | DSDD | DSDSEL[0] | 00H |
| 07H | Control 5 | 0 | 0 | 0 | 0 | 0 | 0 | 1 | SYNCE | 03H |
| 08H | Control 6 | L | R | 0 | 0 | 0 | 0 | 0 | 0 | 00H |
| 09H | DSD2 | 0 | 0 | 0 | 0 | 0 | 0 | DSDF | DSDSEL[1] | 00H |
| 0AH | Control 7 | TDM[1] | TDM[0] | SDS[1] | SDS[2] | 1 | PW | 0 | 1 | 0DH |
| 0BH | Control 8 | ATS[1] | ATS[0] | 0 | SDS[0] | 1 | 1 | 0 | 0 | 0CH |
| 0CH | READONLY1 | 0 | 0 | 0 | 0 | 0 | 0 | 0 | 0 | 00H |
| 0DH | READONLY2 | 0 | 0 | 0 | 0 | 0 | 0 | 0 | 0 | 00H |
| 0EH | READONLY3 | 0 | 1 | 0 | 1 | 0 | 0 | 0 | 0 | 50H |
| 0FH | READONLY4 | 1 | 1 | 1 | 1 | 1 | 1 | 1 | 1 | FFH |
| 10H | READONLY5 | 1 | 1 | 1 | 1 | 1 | 1 | 1 | 1 | FFH |
| 11H | READONLY6 | 1 | 1 | 1 | 1 | 1 | 1 | 1 | 1 | FFH |
| 12H | READONLY7 | 1 | 1 | 1 | 1 | 1 | 1 | 1 | 1 | FFH |
| 13H | READONLY8 | 1 | 1 | 1 | 1 | 1 | 1 | 1 | 1 | FFH |
| 14H | READONLY9 | 1 | 1 | 1 | 1 | 1 | 1 | 1 | 1 | FFH |
| 15H | Control 12 | ADPE | ADPT[1] | ADPT[0] | 0 | 0 | 0 | 0 | 0 | 00H |
| 16H | DoP1 | DOP | DMMI | ADOP | ADOPE | 0 | 0 | 0 | 0 | 00H |
| 17H | DoP2 | DOPSEL[1] | DOPSEL[0] | 0 | 0 | 0 | 0 | 0 | 0 | 00H |
| 18H | DSD MARKERE | DMIE[7] | DMIE[6] | DMIE[5] | DMIE[4] | DMIE[3] | DMIE[2] | DMIE[1] | DMIE[0] | 05H |
| 19H | DSD MARKERO | DMIO[7] | DMIO[6] | DMIO[5] | DMIO[4] | DMIO[3] | DMIO[2] | DMIO[1] | DMIO[0] | FAH |

Notes:

- (1) In 3-wire serial control mode, the AK4462 does not support read commands.
- (2) The AK4462 supports read command in I²C-Bus control mode.
- (3) If the address exceeds "19H", the address counter will "roll over" to "00H" and the next write/read address will be "00H" by automatic increment function in I²C-Bus control mode.
- (4) Bits indicated as 0 in each address must contain a "0" value. Likewise, bits indicated as 1 in each address must contain a "1" value. Malfunctions may occur if writing the reverse value to these bits.
- (5) Writing data to addresses after 19H is forbidden. Malfunctions may also occur by this action.
- (6) When the PDN pin goes to "L", the registers are initialized to their default values.
- (7) When RSTN bit is set to "0", the digital block except control registers and clock divider is reset, and the registers are not initialized to their default values.
- (8) When the PS pin status is changed, the AK4462 should be reset by the PDN pin.

9.19. Register Definitions

| Addr | Register Name | D7 | D6 | D5 | D4 | D3 | D2 | D1 | D0 |
|------|---------------|------|-----|-----|-----|--------|--------|--------|------|
| 00H | Control 1 | ACKS | 0 | 0 | 0 | DIF[2] | DIF[1] | DIF[0] | RSTN |
| | R/W | R/W | R/W | R/W | R/W | R/W | R/W | R/W | R/W |
| | Default | 0 | 0 | 0 | 0 | 1 | 1 | 0 | 0 |

RSTN: Internal timing reset
 0: Reset. All registers are not initialized. (default)
 1: Normal operation

DIF[2:0]: Audio data interface modes select ([Table 24](#))
 The default value is "110" (Mode6: 32-bit MSB justified).

ACKS: Master clock frequency auto setting mode enable (PCM mode and DoP mode). ([Table 6](#), [Table 7](#), [Table 10](#))
 0: Disable: Manual setting mode (default)
 1: Enable: Auto setting mode

| Addr | Register Name | D7 | D6 | D5 | D4 | D3 | D2 | D1 | D0 |
|------|---------------|-----|-----|-----|--------|--------|--------|--------|-------|
| 01H | Control 2 | 0 | 0 | SD | DFS[1] | DFS[0] | DEM[1] | DEM[0] | SMUTE |
| | R/W | R/W | R/W | R/W | R/W | R/W | R/W | R/W | R/W |
| | Default | 0 | 0 | 1 | 0 | 0 | 0 | 1 | 0 |

SMUTE: Soft mute enable
 0: Normal operation (default)
 1: DAC outputs soft-muted.

DEM[1:0]: De-emphasis filter control ([Table 31](#))
 The default value is "01" (OFF).

DFS[2:0]: PCM Sampling speed control ([Table 7](#))
 The default value is "000" (Normal Speed). Click noise occurs when DFS[2:0] bits are changed. See also Addr. 05H.

SD: Short delay filter Enable ([Table 29](#))
 0: Traditional Filter (SSLOW = "0")
 Super Slow Roll-off Filter (SSLOW = "1")
 1: Short delay Filter (SSLOW = "0", default)
 Low Dispersion Filter (SSLOW = "1")

| Addr | Register Name | D7 | D6 | D5 | D4 | D3 | D2 | D1 | D0 |
|------|---------------|-----|-----|------|------|------|------|-------|------|
| 02H | Control 3 | DP | ADP | DCKS | DCKB | MONO | DZFB | SELLR | SLOW |
| | R/W | R/W | R | R/W | R/W | R/W | R/W | R/W | R/W |
| | Default | 0 | 0 | 0 | 0 | 0 | 0 | 0 | 0 |

SLOW: Slow roll-off filter enable ([Table 29](#))
 0: Slow roll-off filter disable (default)
 1: Slow roll-off filter

SELLR: Data selection of L channel and R channel ([Table 38](#))

DZFB: Inverting enable of DZF ([Table 34](#))
 0: DZF pin goes "H" at Zero Detection (default)
 1: DZF pin goes "L" at Zero Detection

MONO: MONO/Stereo mode select
 0: Stereo Mode (default)
 1: Mono Mode

DCKB: Polarity of DCLK (DSD mode only)
 0: DSD data is output from DCLK falling edge. (default)
 1: DSD data is output from DCLK rising edge.

DCKS: Master clock frequency select at DSD mode and DoP mode
 0: 512fs (default)
 1: 768fs

ADP: Read Back Register for Internal Operation Mode. This bit is valid when ADPE bit = "1".
 It is invalid when ADPE bit = "0" and readouts "0" when read.
 0: PCM mode
 1: DSD mode

DP: DSD/PCM mode select
 0: PCM mode (default)
 1: DSD mode
 *When DP bit is changed, the AK4462 should be reset by RSTN bit.

| Addr | Register Name | D7 | D6 | D5 | D4 | D3 | D2 | D1 | D0 |
|------|---------------|---------|---------|---------|---------|---------|---------|---------|---------|
| 03H | Lch ATT | ATTL[7] | ATTL[6] | ATTL[5] | ATTL[4] | ATTL[3] | ATTL[2] | ATTL[1] | ATTL[0] |
| 04H | Rch ATT | ATTR[7] | ATTR[6] | ATTR[5] | ATTR[4] | ATTR[3] | ATTR[2] | ATTR[1] | ATTR[0] |
| | R/W | R/W | R/W | R/W | R/W | R/W | R/W | R/W | R/W |
| | Default | 1 | 1 | 1 | 1 | 1 | 1 | 1 | 1 |

ATTL[7:0]: L channel attenuation level setting ([Table 32](#))

ATTR[7:0]: R channel attenuation level setting ([Table 32](#))

| Addr | Register Name | D7 | D6 | D5 | D4 | D3 | D2 | D1 | D0 |
|------|---------------|------|------|-----|-----|-----|-----|--------|-------|
| 05H | Control 4 | INVL | INVR | 0 | 0 | 0 | 0 | DFS[2] | SSLOW |
| | R/W | R/W | R/W | R/W | R/W | R/W | R/W | R/W | R/W |
| | Default | 0 | 0 | 0 | 0 | 0 | 0 | 0 | 0 |

SSLOW: Super slow roll-off (Digital filter bypass mode) Enable ([Table 29](#))

0: Disable (default)

1: Enable

DFS[2:0]: Sampling speed control ([Table 7](#))

The default value is "000" (Normal Speed). Click noise occurs when DFS[2:0] bits are changed. See also Addr. 01H.

INVR: AOUTR Output Phase Inverting Mode

0: Disable (default)

1: Enable

INVL: AOUTL Output Phase Inverting Mode

0: Disable (default)

1: Enable

| Addr | Register Name | D7 | D6 | D5 | D4 | D3 | D2 | D1 | D0 |
|------|---------------|-----|-----|-----|-------|-----|------|------|-----------|
| 06H | DSD1 | DDM | DML | DMR | DDMOE | 0 | DDMT | DSDD | DSDSEL[0] |
| | R/W | R/W | R | R | R/W | R/W | R/W | R/W | R/W |
| | Default | 0 | 0 | 0 | 0 | 0 | 0 | 0 | 0 |

DSDSEL[1:0]: DSD sampling speed control ([Table 15](#)) . See also Addr. 09H.

DSDD: DSD playback path control

0: Normal Path (default)

1: Volume Bypass

DDMT: DSD Signal Full-scale Detection Time Setting ([Table 36](#))

DDMOE: Output Flag Selection from the DZF pin ([Table 34](#))

DML/R: This register outputs detection flag when a full-scale signal is detected at DSDL/R channel.

DDM: DSD data mute

The AK4462 has an internal mute function that mutes the output when DSD input data becomes all "1" or all "0" for 2048 samples (1/fs) continuously. DDM bit controls this function.

0: Disable (default)

1: Enable

| Addr | Register Name | D7 | D6 | D5 | D4 | D3 | D2 | D1 | D0 |
|------|---------------|-----|-----|-----|-----|-----|-----|-----|-------|
| 07H | Control 5 | 0 | 0 | 0 | 0 | 0 | 0 | 1 | SYNCE |
| | R/W | R/W | R/W | R/W | R/W | R/W | R/W | R/W | R/W |
| | Default | 0 | 0 | 0 | 0 | 0 | 0 | 1 | 1 |

SYNCE: SYNC mode enable
 0: SYNC mode disable
 1: SYNC mode enable (default)

| Addr | Register Name | D7 | D6 | D5 | D4 | D3 | D2 | D1 | D0 |
|------|---------------|-----|-----|-----|-----|-----|-----|-----|-----|
| 08H | Control 6 | L | R | 0 | 0 | 0 | 0 | 0 | 0 |
| | R/W | R/W | R/W | R/W | R/W | R/W | R/W | R/W | R/W |
| | Default | 0 | 0 | 0 | 0 | 0 | 0 | 0 | 0 |

L, R Zero Detect Flag Enable Bit for the DZF pin
 0: Disable (default)
 1: Enable

| Addr | Register Name | D7 | D6 | D5 | D4 | D3 | D2 | D1 | D0 |
|------|---------------|-----|-----|-----|-----|-----|-----|------|-----------|
| 09H | DSD2 | 0 | 0 | 0 | 0 | 0 | 0 | DSDF | DSDSEL[1] |
| | R/W | R/W | R/W | R/W | R/W | R/W | R/W | R/W | R/W |
| | Default | 0 | 0 | 0 | 0 | 0 | 0 | 0 | 0 |

DSDSEL[1]:DSD sampling speed control ([Table 15](#)). See also Addr. 09H.

DSDF: Cut-off frequency of DSD filter control

| Addr | Register Name | D7 | D6 | D5 | D4 | D3 | D2 | D1 | D0 |
|------|---------------|--------|--------|--------|--------|-----|-----|-----|-----|
| 0AH | Control7 | TDM[1] | TDM[0] | SDS[1] | SDS[2] | 1 | PW | 0 | 1 |
| | R/W | R/W | R/W | R/W | R/W | R/W | R/W | R/W | R/W |
| | Default | 0 | 0 | 0 | 0 | 1 | 1 | 0 | 1 |

PW: DAC Power control ([Table 43](#))

SDS[2:0]: Output Data Slot Selection of Each Channel ([Table 25](#))
 The default value is "000". See also Addr. 0BH.

TDM[1:0]: TDM mode select
 00: Normal (default)
 01: TDM128
 10: TDM256
 11: TDM512

| Addr | Register Name | D7 | D6 | D5 | D4 | D3 | D2 | D1 | D0 |
|------|---------------|--------|--------|-----|--------|-----|-----|-----|-----|
| 0BH | Control 8 | ATS[1] | ATS[0] | 0 | SDS[0] | 1 | 1 | 0 | 0 |
| | R/W | R/W | R/W | R/W | R/W | R/W | R/W | R/W | R/W |
| | Default | 0 | 0 | 0 | 0 | 1 | 1 | 0 | 0 |

SDS[2:0]: Output Data Slot Selection of Each Channel ([Table 25](#))
The default value is "000". See also Addr. 0AH.

ATS[1:0]: Transition time between set values of ATTL/R[7:0] bits ([Table 33](#))
The default value is "00".

| Addr | Register Name | D7 | D6 | D5 | D4 | D3 | D2 | D1 | D0 |
|------|---------------|----|----|----|----|----|----|----|----|
| 0CH | READONLY1 | 0 | 0 | 0 | 0 | 0 | 0 | 0 | 0 |
| 0DH | READONLY2 | 0 | 0 | 0 | 0 | 0 | 0 | 0 | 0 |
| 0EH | READONLY3 | 0 | 1 | 0 | 1 | 0 | 0 | 0 | 0 |
| 0FH | READONLY4 | 1 | 1 | 1 | 1 | 1 | 1 | 1 | 1 |
| 10H | READONLY5 | 1 | 1 | 1 | 1 | 1 | 1 | 1 | 1 |
| 11H | READONLY6 | 1 | 1 | 1 | 1 | 1 | 1 | 1 | 1 |
| 12H | READONLY7 | 1 | 1 | 1 | 1 | 1 | 1 | 1 | 1 |
| 13H | READONLY8 | 1 | 1 | 1 | 1 | 1 | 1 | 1 | 1 |
| 14H | READONLY9 | 1 | 1 | 1 | 1 | 1 | 1 | 1 | 1 |
| | R/W | R | R | R | R | R | R | R | R |

| Addr | Register Name | D7 | D6 | D5 | D4 | D3 | D2 | D1 | D0 |
|------|---------------|------|---------|---------|-----|-----|-----|-----|-----|
| 15H | Control 12 | ADPE | ADPT[1] | ADPT[0] | 0 | 0 | 0 | 0 | 0 |
| | R/W | R/W | R/W | R/W | R/W | R/W | R/W | R/W | R/W |
| | Default | 0 | 0 | 0 | 0 | 0 | 0 | 0 | 0 |

ADPT[1:0]: Time until PCM/DSD mode detection when input data becomes zero ([Table 39](#))

ADPE: PCM/DSD Automatic Mode Switching Function Enable Bit
0 : Disable (default)
1 : Enable

| Addr | Register Name | D7 | D6 | D5 | D4 | D3 | D2 | D1 | D0 |
|------|---------------|-----|------|------|-------|-----|-----|-----|-----|
| 16H | DoP1 | DOP | DMMI | ADOP | ADOPE | 0 | 0 | 0 | 0 |
| | R/W | R/W | R/W | R | R/W | R/W | R/W | R/W | R/W |
| | Default | 0 | 0 | 0 | 0 | 0 | 0 | 0 | 0 |

ADOPE: PCM/DoP Automatic Mode Switching Function Enable Bit
 0 : Disable (default)
 1 : Enable

ADOP: Read Back Register for Internal Operation Mode. This bit is valid when ADOPE bit = "1".
 It is invalid when ADOPE bit = "0" and readouts "0" when read.
 0: PCM mode
 1: DoP mode

DMMI: DoP Data Detection Code Setting ([Table 27](#))

DOP: DoP Mode enable.
 0 : Disable (default)
 1 : Enable

| Addr | Register Name | D7 | D6 | D5 | D4 | D3 | D2 | D1 | D0 |
|------|---------------|------------|------------|-----|-----|-----|-----|-----|-----|
| 17H | DoP2 | DOP SEL[1] | DOP SEL[0] | 0 | 0 | 0 | 0 | 0 | 0 |
| | R/W | R/W | R/W | R/W | R/W | R/W | R/W | R/W | R/W |
| | Default | 0 | 0 | 0 | 0 | 0 | 0 | 0 | 0 |

DOPSEL[1:0]: DoP Sampling Speed Control ([Table 18](#))

| Addr | Register Name | D7 | D6 | D5 | D4 | D3 | D2 | D1 | D0 |
|------|---------------|----------|----------|----------|----------|----------|----------|----------|----------|
| 18H | DSDMARKERE | DMIE [7] | DMIE [6] | DMIE [5] | DMIE [4] | DMIE [3] | DMIE [2] | DMIE [1] | DMIE [0] |
| | R/W | R/W | R/W | R/W | R/W | R/W | R/W | R/W | R/W |
| | Default | 0 | 0 | 0 | 0 | 0 | 1 | 0 | 1 |

DMIE [7:0]: EVEN Marker Setting (Valid only when DMMI bit = "1")

| Addr | Register Name | D7 | D6 | D5 | D4 | D3 | D2 | D1 | D0 |
|------|---------------|----------|----------|----------|----------|----------|----------|----------|----------|
| 19H | DSDMARKERO | DMIO [7] | DMIO [6] | DMIO [5] | DMIO [4] | DMIO [3] | DMIO [2] | DMIO [1] | DMIO [0] |
| | R/W | R/W | R/W | R/W | R/W | R/W | R/W | R/W | R/W |
| | Default | 1 | 1 | 1 | 1 | 1 | 0 | 1 | 0 |

DMIO [7:0]: ODD Marker Setting (Valid only when DMMI bit = "1")

10. Recommended External Circuits

10.1. Recommended External Circuits

10.1.1. Register Control Mode, LDO Disable.

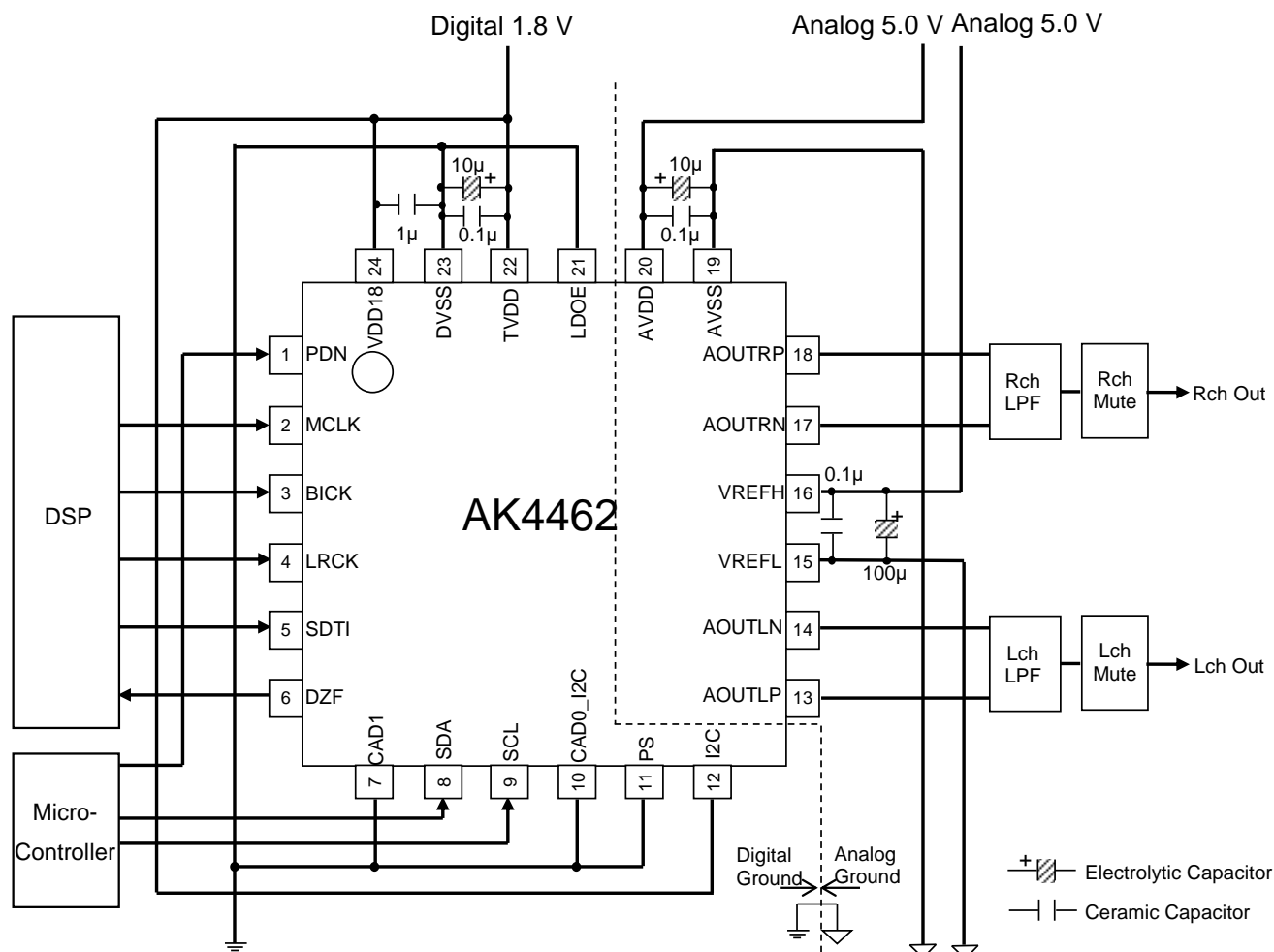

Notes:

- (1) Power lines of AVDD and TVDD should be distributed separately with low impedance of regulators, etc. maintained.
- (2) AVSS and DVSS must be connected to the same analog ground plane. (Analog ground should have low impedance as a solid pattern. THD+N characteristics will degrade if there are impedances between each VSS.)
- (3) It is recommended to input MCLK via a damping resistor. Without the resistor, there is a possibility that THD+N characteristic degrades because of high-frequency noise of MCLK.
- (4) Power lines of AVDD and VREFH should be distributed separately with low impedance of regulators, etc. maintained. It is recommended to separate the wiring of AVDD and VREFH. It is also recommended to connect a 0.1 μF and a 220 μF capacitors between VREFL and VREFH.
- (5) All digital input pins except pulldown/pull-up pins should not be allowed to float.

Figure 79. Typical Connection Diagram
(AVDD = 5.0 V, TVDD = 1.8 V, VDD18 = 1.8 V, LDOE pin = "L", Register Control Mode)

10.1.2. Register control mode, LDO enable

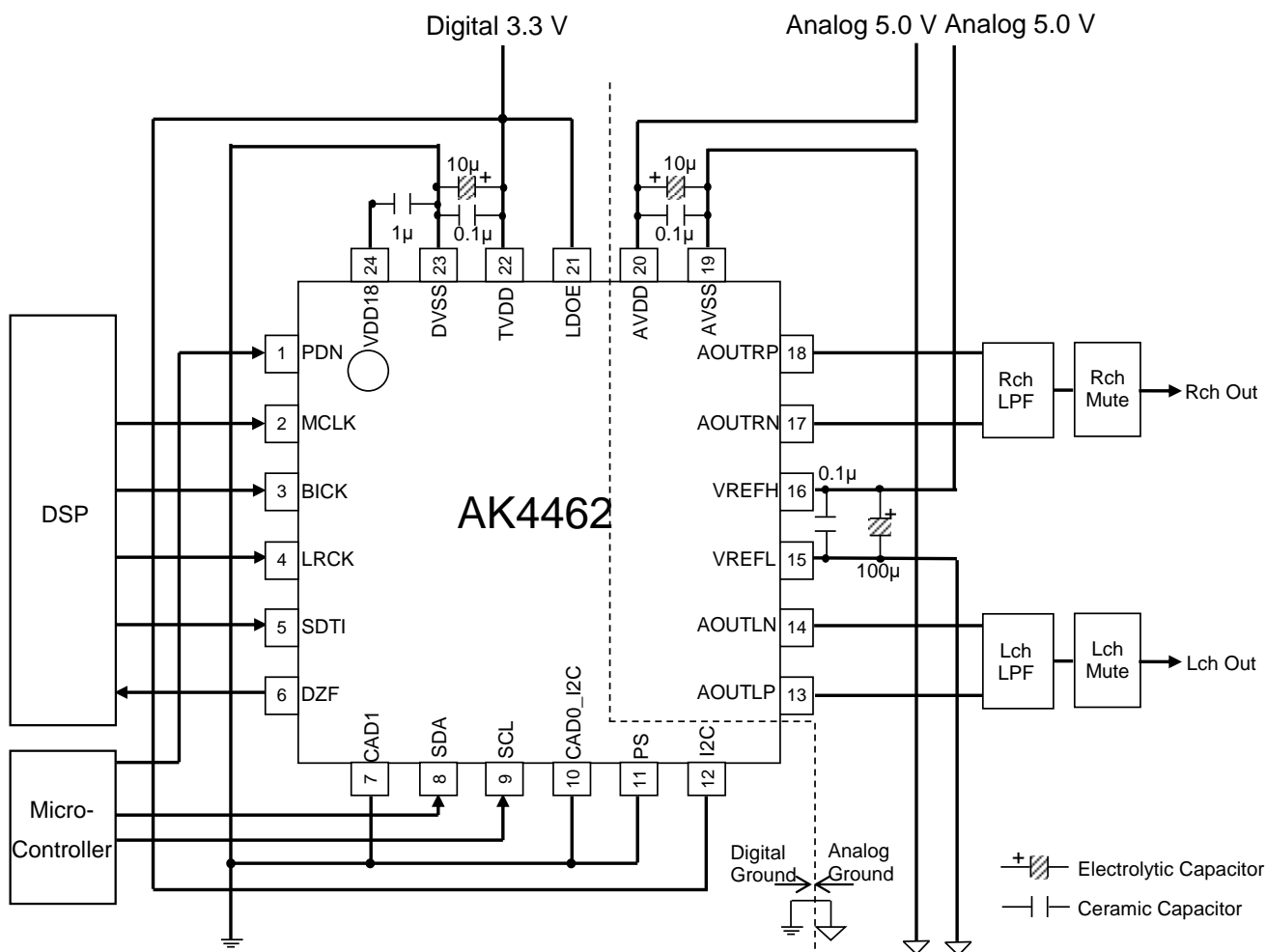

Notes:

- (1) Power lines of AVDD and TVDD should be distributed separately with low impedance of regulators, etc. maintained.
- (2) AVSS and DVSS must be connected to the same analog ground plane. (Analog ground should have low impedance as a solid pattern. THD+N characteristics will degrade if there are impedances between each VSS.)
- (3) It is recommended to input MCLK via a damping resistor. Without the resistor, there is a possibility that THD+N characteristic degrades because of high-frequency noise of MCLK.
- (4) Power lines of AVDD and VREFH should be distributed separately with low impedance of regulators, etc. maintained. It is recommended to separate the wiring of AVDD and VREFH. It is also recommended to connect a 0.1 μ F and a 220 μ F capacitors between VREFL and VREFH.
- (5) All digital input pins except pulldown/pull-up pins should not be allowed to float.
- (6) A 1 μ F capacitor ($\pm 50\%$, including temperature characteristics) must be connected to the VDD18 pin.

Figure 80. Typical Connection Diagram
(AVDD = 5.0 V, TVDD = 3.3 V, LDOE pin = "H", Register Control Mode)

10.2. Grounding and Power Supply Decoupling

To minimize coupling of digital noise, decoupling capacitors should be connected to AVDD, TVDD and VDD18. AVDD is supplied from analog supply in system, and TVDD and VDD18 are supplied from digital supply in system. Power line of AVDD should be distributed separately, from the point with low impedance of regulators or other parts. When not using the LDO (LDOE pin = "L"), TVDD must be powered up before or at the same time of VDD18.

AVSS and DVSS must be connected to the same analog ground plane. Decoupling capacitors for high frequency should be placed as near as possible to the AK4462.

10.3. Reference Voltage

The VREFH pin is normally connected to 5.0 V reference voltage, and the VREFL pin is normally connected to the analog ground. Connect a 0.1 μF ceramic and a 220 μF electrolytic capacitors between VREFH and VREFL. Especially the ceramic capacitors should be connected as near as possible to the pin.

The potential difference between VREFH and VREFL set the full-scale of the analog output range. Therefore, the VREFH and VREFL pins should avoid noises from other power supplies. When it is difficult to obtain expected analog characteristics because of noises from other power supplies, connect the VREFH pin to the analog 5.0 V via a 10 Ω resistor, and the VREFL pin to the analog ground via a 10 Ω resistor. In addition, connect a 220 μF electrolytic capacitor between VREFH and VREFL. A low pass filter of $f_c = 36$ Hz will be composed with the 220 μF capacitor and the 10 Ω resistor. It removes differential noise between VREFH and VREFL.

All digital signals, especially clocks, should be kept away from the VREFH and VREFL pins in order to avoid unwanted coupling into the AK4462.

10.4. Analog Output

The analog outputs are full differential outputs. The differential outputs are summed externally. When the summing gain is 1 and $V_{REFH} - V_{REFL} = 5\text{ V}$, the output range is 5.6 V_{pp} (Typ.). The bias voltage of the external summing circuit is supplied externally.

Figure 81 and Figure 82 shows examples of external LPF circuit summing the differential outputs by a single op-amp. Figure 83 shows an example of external LPF with two op-amps and differential output circuits.

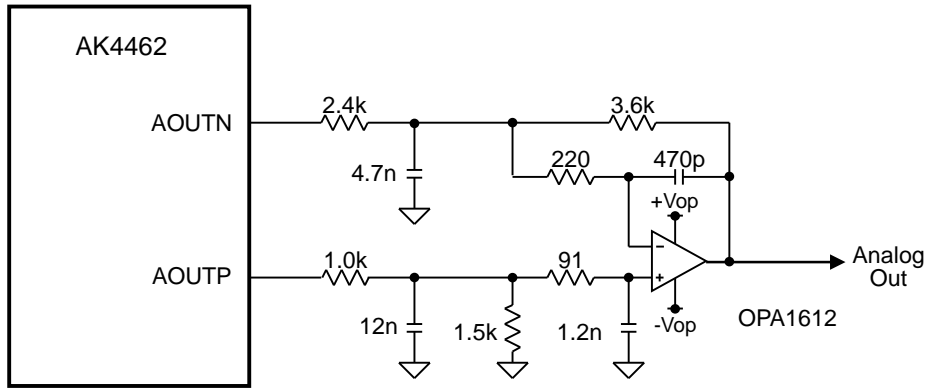

Figure 81. External LPF Circuit Example 1 ($f_c = 111$ (Typ.), $Q = 0.677$ (Typ.))

Table 44. Frequency Response of External LPF Circuit Example 1

| | | |
|--------------------------------------|--------|----------|
| Gain (1 kHz, Typ.) | | +3.52 dB |
| Frequency Response (ref:1 kHz, Typ.) | 20 kHz | -0.16 dB |
| | 40 kHz | -0.35 dB |
| | 80 kHz | -1.31 dB |

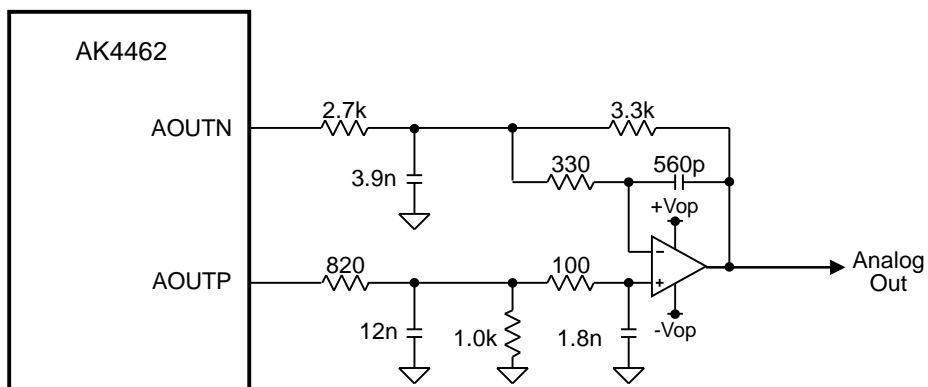

Figure 82. External LPF Circuit Example 2 ($f_c = 103\text{ kHz}$ (Typ.), $Q = 0.651$ (Typ.))

Table 45. Frequency Response of External LPF Circuit Example 2

| | | |
|--------------------------------------|--------|----------|
| Gain (1 kHz, Typ.) | | +1.74 dB |
| Frequency Response (ref:1 kHz, Typ.) | 20 kHz | +0.06 dB |
| | 40 kHz | +0.01 dB |
| | 80 kHz | -1.43 dB |

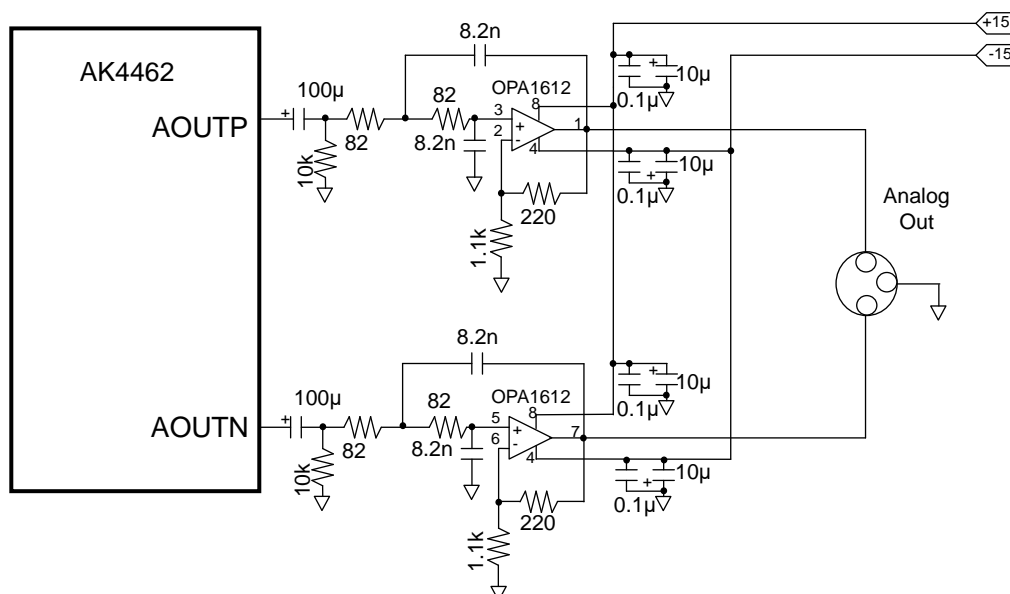

Figure 83. External LPF Circuit Example 2 ($f_c = 174 \text{ kHz (Typ.)}$, $Q = 0.5 \text{ (Typ.)}$)

Table 46. Frequency Response of External LPF Circuit Example 3

| | | |
|---------------------------------------|--------|----------|
| Gain (1 kHz, Typ.) | | +1.58 dB |
| Frequency Response (ref: 1 kHz, Typ.) | 20 kHz | -0.03 dB |
| | 40 kHz | -0.15 dB |
| | 80 kHz | -0.62 dB |

11. Package

11.1. Outline Dimensions
24-pin QFN (Unit mm)

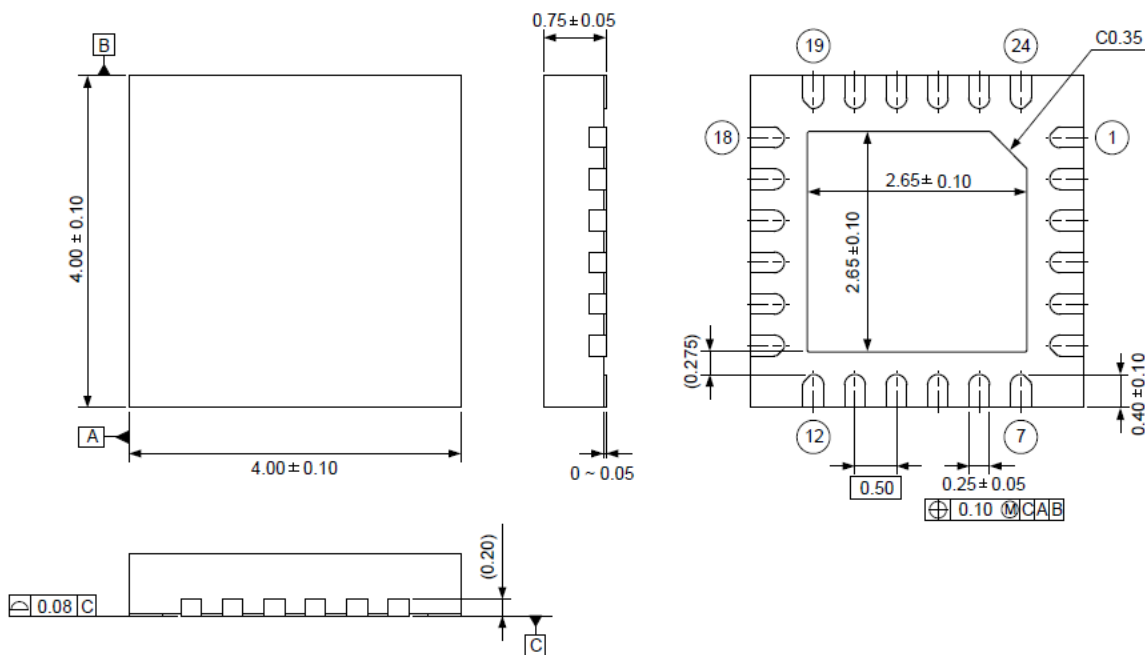

11.2. Material & Lead Finish

Package molding compound: Epoxy
 Lead frame material: EFTEC-64T
 Pin surface treatment: Solder (Pb free) plate

11.3. Marking

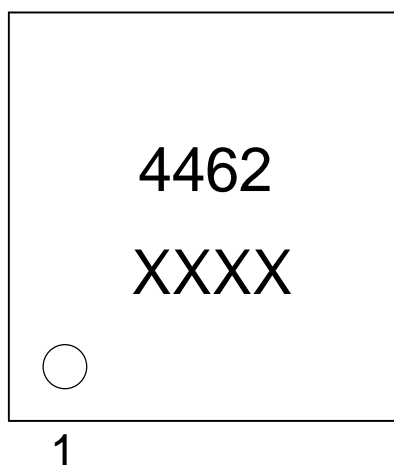

- 1) Pin #1 indication
- 2) Date Code: XXXX (4 digits)
- 3) Marking Code: 4462

12. Ordering Guide

AK4462VN -40–105 °C 24-pin QFN
AKD4462 Evaluation Board for AK4462

13. Revision History

| Date (Y/M/D) | Revision | Reason | Page | Contents |
|--------------|----------|---------------|------|----------|
| 19/11/29 | 00 | First Edition | | |

IMPORTANT NOTICE

0. Asahi Kasei Microdevices Corporation (“AKM”) reserves the right to make changes to the information contained in this document without notice. When you consider any use or application of AKM product stipulated in this document (“Product”), please make inquiries the sales office of AKM or authorized distributors as to current status of the Products.
1. All information included in this document are provided only to illustrate the operation and application examples of AKM Products. AKM neither makes warranties or representations with respect to the accuracy or completeness of the information contained in this document nor grants any license to any intellectual property rights or any other rights of AKM or any third party with respect to the information in this document. You are fully responsible for use of such information contained in this document in your product design or applications. AKM ASSUMES NO LIABILITY FOR ANY LOSSES INCURRED BY YOU OR THIRD PARTIES ARISING FROM THE USE OF SUCH INFORMATION IN YOUR PRODUCT DESIGN OR APPLICATIONS.
2. The Product is neither intended nor warranted for use in equipment or systems that require extraordinarily high levels of quality and/or reliability and/or a malfunction or failure of which may cause loss of human life, bodily injury, serious property damage or serious public impact, including but not limited to, equipment used in nuclear facilities, equipment used in the aerospace industry, medical equipment, equipment used for automobiles, trains, ships and other transportation, traffic signaling equipment, equipment used to control combustions or explosions, safety devices, elevators and escalators, devices related to electric power, and equipment used in finance-related fields. Do not use Product for the above use unless specifically agreed by AKM in writing.
3. Though AKM works continually to improve the Product’s quality and reliability, you are responsible for complying with safety standards and for providing adequate designs and safeguards for your hardware, software and systems which minimize risk and avoid situations in which a malfunction or failure of the Product could cause loss of human life, bodily injury or damage to property, including data loss or corruption.
4. Do not use or otherwise make available the Product or related technology or any information contained in this document for any military purposes, including without limitation, for the design, development, use, stockpiling or manufacturing of nuclear, chemical, or biological weapons or missile technology products (mass destruction weapons). When exporting the Products or related technology or any information contained in this document, you should comply with the applicable export control laws and regulations and follow the procedures required by such laws and regulations. The Products and related technology may not be used for or incorporated into any products or systems whose manufacture, use, or sale is prohibited under any applicable domestic or foreign laws or regulations.
5. Please contact AKM sales representative for details as to environmental matters such as the RoHS compatibility of the Product. Please use the Product in compliance with all applicable laws and regulations that regulate the inclusion or use of controlled substances, including without limitation, the EU RoHS Directive. AKM assumes no liability for damages or losses occurring as a result of noncompliance with applicable laws and regulations.
6. Resale of the Product with provisions different from the statement and/or technical features set forth in this document shall immediately void any warranty granted by AKM for the Product and shall not create or extend in any manner whatsoever, any liability of AKM.
7. This document may not be reproduced or duplicated, in any form, in whole or in part, without prior written consent of AKM.

Rev.1