

RECOMMENDED PC BOARD LAYOUT (Component side)

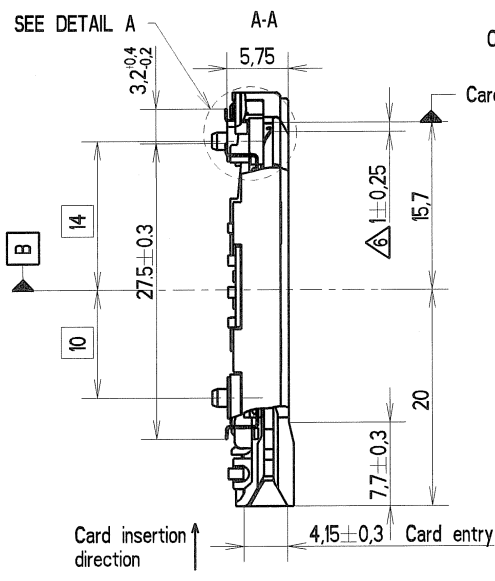
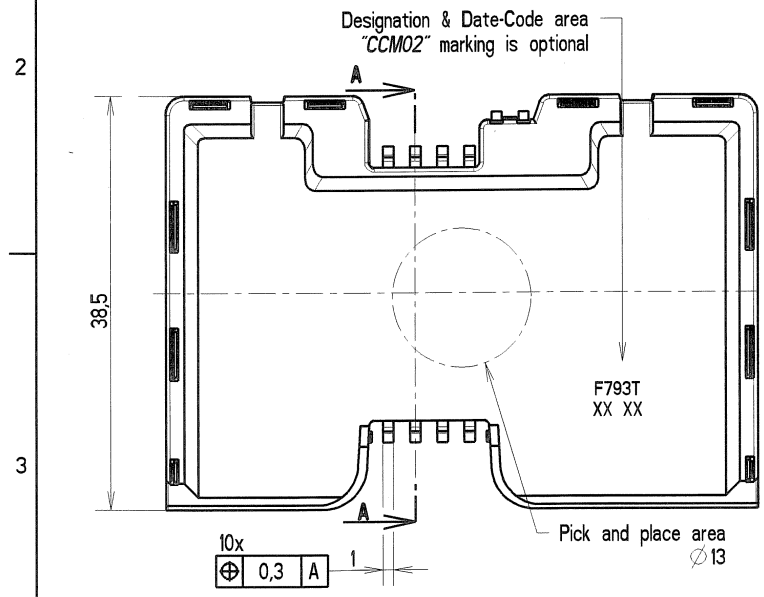
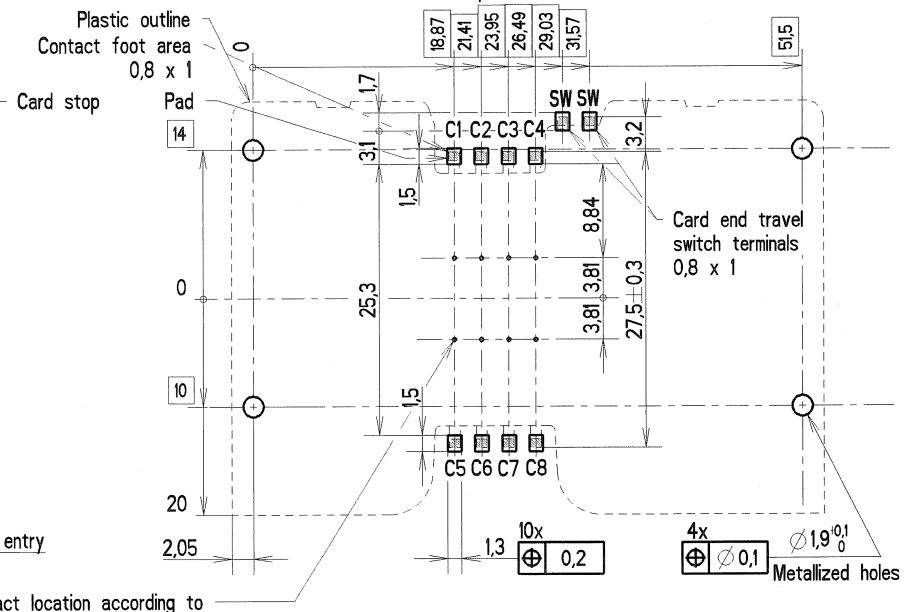

Packaging	Packaging drawing	Designation	Part Number
Tray	O30278Y0041	CCM02-F793 LFT	Y1122-F793A LFT

- Notes :
- 1 - Termination to PCB : SMT reflow soldering
Temperature/time profile according to : C&K PS-LF-001 specification.
Since there are no boardlocks, the connector must be held in place on the PCB across the top face of the cover.
 - 2 - Level of each contact tail compared to the nearest plastic stand-off.
Coplanarity of metal soldering surfaces : 0,15 mm.
 - 3 - Recommendation for solder paste thickness > 0,2 mm.
 - 4 - 2,5 microns min tin plating on contact terminal areas and 0,1 microns min gold plating on switch terminal areas.

- 5 - Contacts forces :
- max 0,5 N per contact with max. card thickness.
- min 0,2 N per contact with min. card thickness.
- 6 - Card end travel switch NO activates when the sliding card is 1 mm from the card stop.
- 7 - In case of customer accessories integration requesting an interface with CCM, please ask C&K for a 3D model.

Contact location according to ISO/IEC 7816-2

MATIERE		TRAITEMENT			PROTECTION	
SAUF INDIQUE :	TOL. LINEAIRE ± 0,1	TOL. ANGULAIRE ± 2	DIMENSIONS CRITIQUES ▼		DIMENSIONS SPC ▼	
-COTES DONNEES AVANT PROTECTION	ETAT DE SURFACE Ra		LANGAGE		E	
-BAVURES ET ARETES VIVES SUPPRIMEES	DESSINE C. DECODTS	DATE 16/10/2008	ANALYSE Y	TAB. FAM. Y	PRO/E Y	LANGAGE E
VERIFIE G. PINON	DATE 16/10/2008	REMPLECE		DESIGNATION		
APPROUVE L. KUBAT	DATE 16/10/2008	PROJECTION 1ER DIEDRE		CCM02-F793 LFT		
G&K Components		ECHELLE 2		4 metal pegs		
BP 359 - 39105 Dole - FRANCE -		TAILLE A3	FEUILLE 1 / 1	NUMERO CU	1122M1YF793	
				REV	-	

CE PLAN EST LA PROPRIETE DE C&K COMPONENTS SAS ET NE PEUT ETRE REPRODUIT OU COMMUNIQUE SANS SON AUTORISATION