



ON Semiconductor®

<http://onsemi.com>

LB8503V

Monolithic Digital IC

DC Fan Motor Speed Control IC

Overview

The LB8503V is an improved functionality version of the LB8500 and LB8502 products that features the added functions listed below. The LB8503V supports both single-phase and three-phase applications.

Added Functions

- Supports origin shifting in the speed control function
- Adds a dedicated pin for setting the soft start time
This allows a longer start time to be set without reducing the response time when changing speed.
- FG output pin added

Functions and Features

- Achieves linear speed control
Applications can set the slope of the change in motor speed with change in the input duty.
- Minimized speed fluctuations in the presence of line or load variations
- Allows a minimum speed to be set
- Soft start function
- Settings using external capacitors and resistors (to support easier mass production of end products)
- Supports both PWM duty and analog voltage control inputs

LB8503V

Specifications

Absolute Maximum Ratings at $T_a = 25^\circ\text{C}$

Parameter	Symbol	Conditions	Ratings	Unit
Supply voltage	$V_{CC\text{ max}}$	V_{CC} pin	18	V
Output current	$I_O\text{ max}$	E0 pin	3	mA
FG output pin output voltage	$V_{FG\text{ max}}$	FGOUT pin	18	V
FG output pin output current	$I_{FG\text{ max}}$	FGOUT pin	10	mA
Allowable power dissipation	$P_d\text{ max}$	When mounted on a circuit board *1	0.8	W
Operating temperature	T_{opr}		-30 to +95	$^\circ\text{C}$
Storage temperature	T_{stg}		-55 to +150	$^\circ\text{C}$

*1 Specified circuit board : $114.3 \times 76.1 \times 1.6\text{mm}^3$, glass epoxy.

Stresses exceeding Maximum Ratings may damage the device. Maximum Ratings are stress ratings only. Functional operation above the Recommended Operating Conditions is not implied. Extended exposure to stresses above the Recommended Operating Conditions may affect device reliability.

Allowable Operating Range at $T_a = 25^\circ\text{C}$

Parameter	Symbol	Conditions	Ratings	Unit
Supply voltage range 1	V_{CC1}	V_{CC} pin	7.5 to 17	V
Supply voltage range 2	V_{CC2}	V_{CC} pin, with V_{CC} shorted to 6VREG	5.5 to 6.5	V
Output current	I_O	E0 pin	2.5	mA
6V constant voltage output current	I_{REG}		-5	mA
CTL pin voltage	V_{CTL}		0 to 6VREG	V
LIM pin voltage	V_{LIM}		0 to 6VREG	V
VC1 pin voltage	V_{CI}		0 to 6VREG	V

Electrical Characteristics at $T_a = 25^\circ\text{C}$, $V_{CC} = 12\text{V}$

Parameter	Symbol	Conditions	Ratings			Unit
			min	typ	max	
Supply current	I_{CC}			5.5	6.5	mA
6V constant voltage output (VREG pin)						
Output voltage	VREG		5.8	6.0	6.2	V
Line regulation	ΔV_{REG1}	$V_{CC} = 8$ to 17V		40	100	mV
Load regulation	ΔV_{REG2}	$I_O = -5$ to 5mA		10	100	mV
Temperature coefficient	ΔV_{REG3}	Design target*		0		$\text{mV}/^\circ\text{C}$
Integrating Amplifier Block (E01)						
Common-mode input voltage range	VICM		2.0		VREG	V
High-level output voltage	$V_{OH}(E01)$	$I_{EO1} = -0.2\text{mA}$	VREG - 1.2	VREG - 0.8		V
Low-level output voltage	$V_{OL}(E01)$	$I_{EO1} = 0.2\text{mA}$		0.8	1.0	V
Integrating Amplifier Block (E03)						
High-level output voltage	$V_{OH}(E03)$	$I_{EO1} = -0.2\text{mA}$	VREG - 1.2	VREG - 0.8		V
Low-level output voltage	$V_{OL}(E03)$	$I_{EO1} = 0.2\text{mA}$		0.8	1.0	V
FGIN pin						
High-level input voltage	VFGH		3.0		VREG	V
Low-level input voltage	VFGL		0		1.5	V
Input open voltage	VFGO		VREG - 0.5		VREG	V
Hysteresis	VFGS		0.2	0.3	0.4	V
High-level input current	IFGH	$V_{FGIN} = 6\text{VREG}$	-10	0	10	μA
Low-level input current	IFGL	$V_{FGIN} = 0\text{V}$	-140	-110		μA
FGOUT pin						
Output low saturation voltage	VFG			0.2	0.3	V
Output leakage current	IFGL				10	μA

Continued on next page.

LB8503V

Continued from preceding page.

Parameter	Symbol	Conditions	Ratings			Unit
			min	typ	max	
RC pin						
High-level output voltage	$V_{OH}(RC)$		3.2	3.45	3.7	V
Low-level output voltage	$V_{OL}(RC)$		0.8	0.95	1.05	V
Clamp voltage	$V_{CLP}(RC)$		1.5	1.65	1.8	V
CTL pin						
High-level input voltage	V_{CTH}		2.0		VREG	V
Low-level input voltage	V_{CTL}		0		1.0	V
Input open voltage	V_{CTO}		VREG - 0.5		VREG	V
High-level input current	I_{CTH}	VFGIN = 6VREG	-10	0	10	μA
Low-level input current	I_{CTL}	VFGIN = 0V	-140	-110		μA
C pin						
High-level input voltage	$V_{OH}(C)$		VREG - 0.3	VREG - 0.1		V
Low-level input voltage	$V_{OL}(C)$		1.8	2.0	2.2	V
LIM pin						
Input bias current	$I_{B}(LIM)$		-1		1	μA
Common-mode input voltage range	VILIM		2.0		VREG	V
SOFT pin						
Charge current	$I_{C}(SOFT)$			1.4		μA
Operation voltage range	VISOFT		2.0		VREG	V
VCI pin						
Input bias current	$I_{B}(VCI)$		-1		1	μA
Common-mode input voltage range	VIVCI		2.0		VREG	V
VCO pin						
High-level output voltage	$V_{OH}(VCO)$			VREG - 0.2		V
Low-level output voltage	$V_{OL}(VCO)$			2.0		V

* The design specification items are design guarantees and are not measured.

Package Dimensions

unit : mm (typ)

3178B

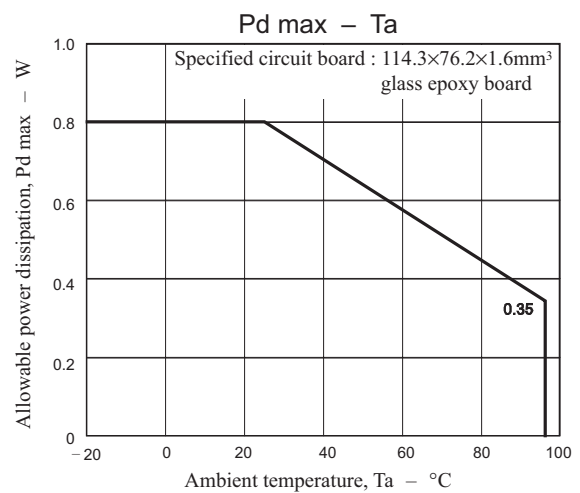
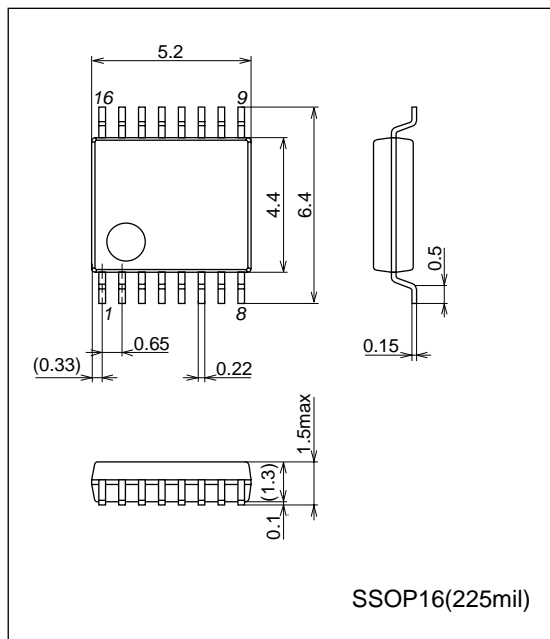

LB8503V

Pin Assignment

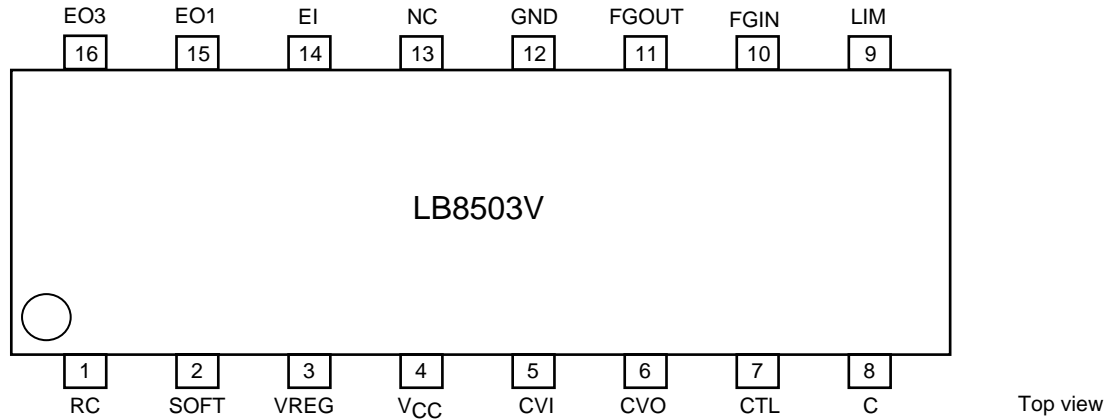

Pin Functions

Pin No.	Pin	Description
RC	1	One-shot multivibrator pulse width setting. Connect a resistor between this pin and VREG, and a capacitor between this pin and ground.
SOFT	2	Soft start time setting. Connect a capacitor between this pin and VREG.
VREG	3	6V regulator output. Connect a capacitor between this pin and ground for stabilization.
V _{CC}	4	Power supply. Connect a capacitor between this pin and ground for stabilization.
CVI	5	Control voltage input
CVO	6	Duty pulse signal smoothed voltage output
CTL	7	Duty pulse signal input. The speed is controlled by the duty of this pulse signal.
C	8	Duty pulse signal smoothing. Connect a capacitor between this pin and VREG.
LIM	9	Minimum speed setting. Normally, the 6V regulator level is resistor divided to set this pin's input level.
FGIN	10	FG pulse input
FGOUT	11	FG pulse output
GND	12	Grand pin
NC	13	NC pin
EI	14	One-shot multivibrator output and integrating amplifier input. A capacitor must be connected between this pin and EO for this integration.
EO1	15	Integrating amplifier output. (For use with an accelerating driver IC if the command voltage becomes low (single-phase systems).)
EO3	16	Integrating amplifier inverting output. (For use with an accelerating driver IC if the command voltage becomes high (three-phase systems).)

LB8503V

Block Diagrams and Application Examples

Combination with an accelerating driver IC when the command voltage goes low (single-phase systems)

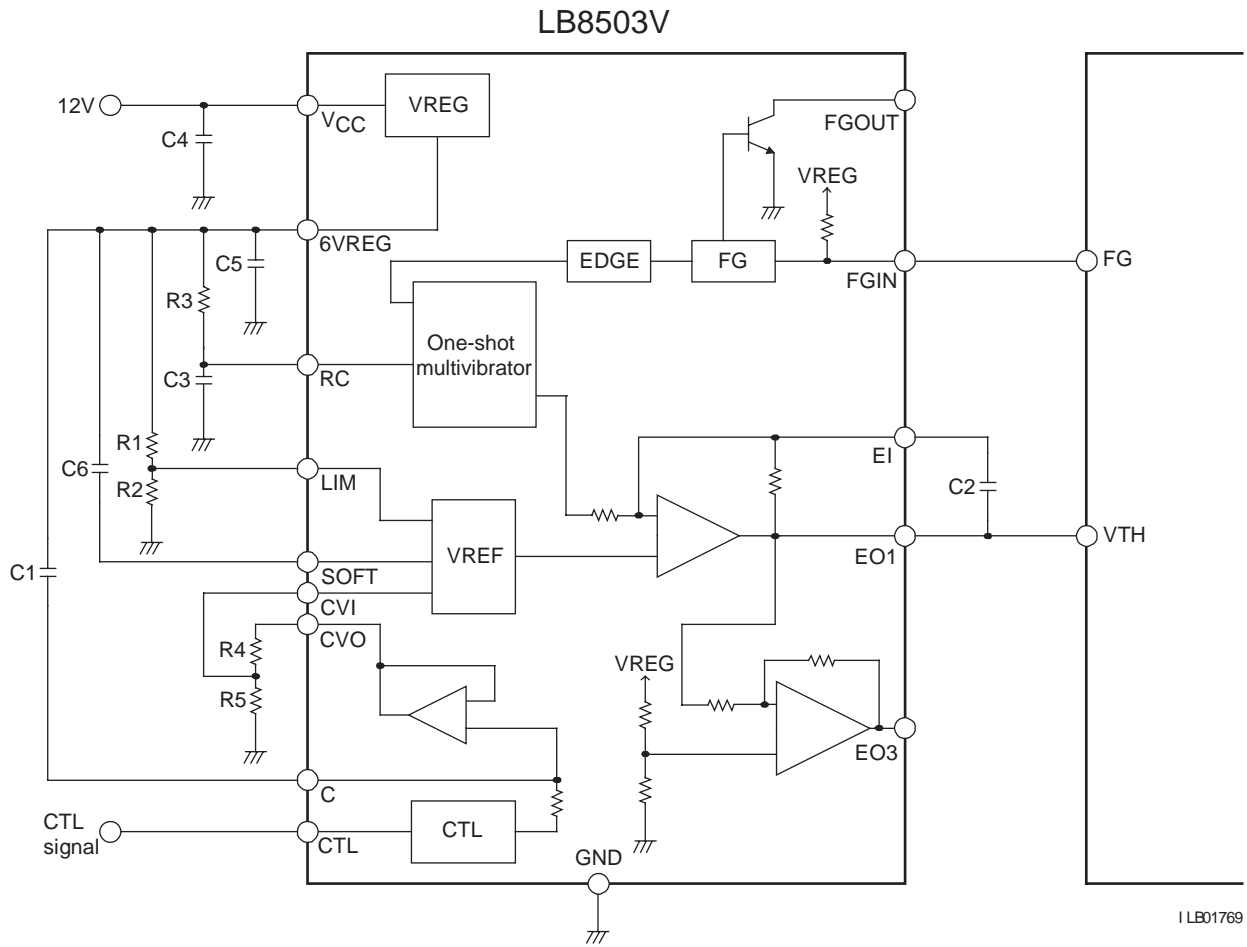

I LB01769

LB8503V

Combination with an accelerating driver IC when the command voltage goes high (three-phase systems)

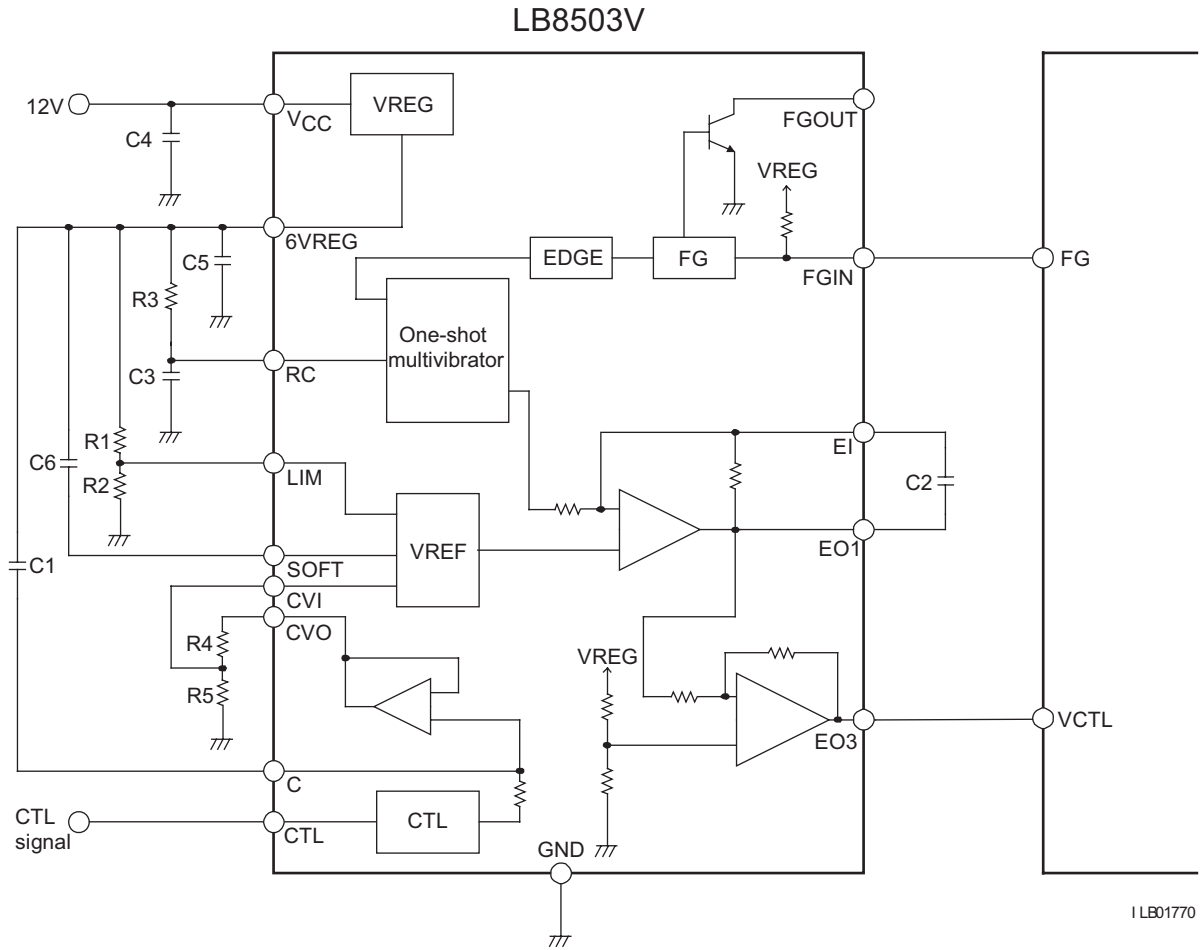

Speed Control Diagrams

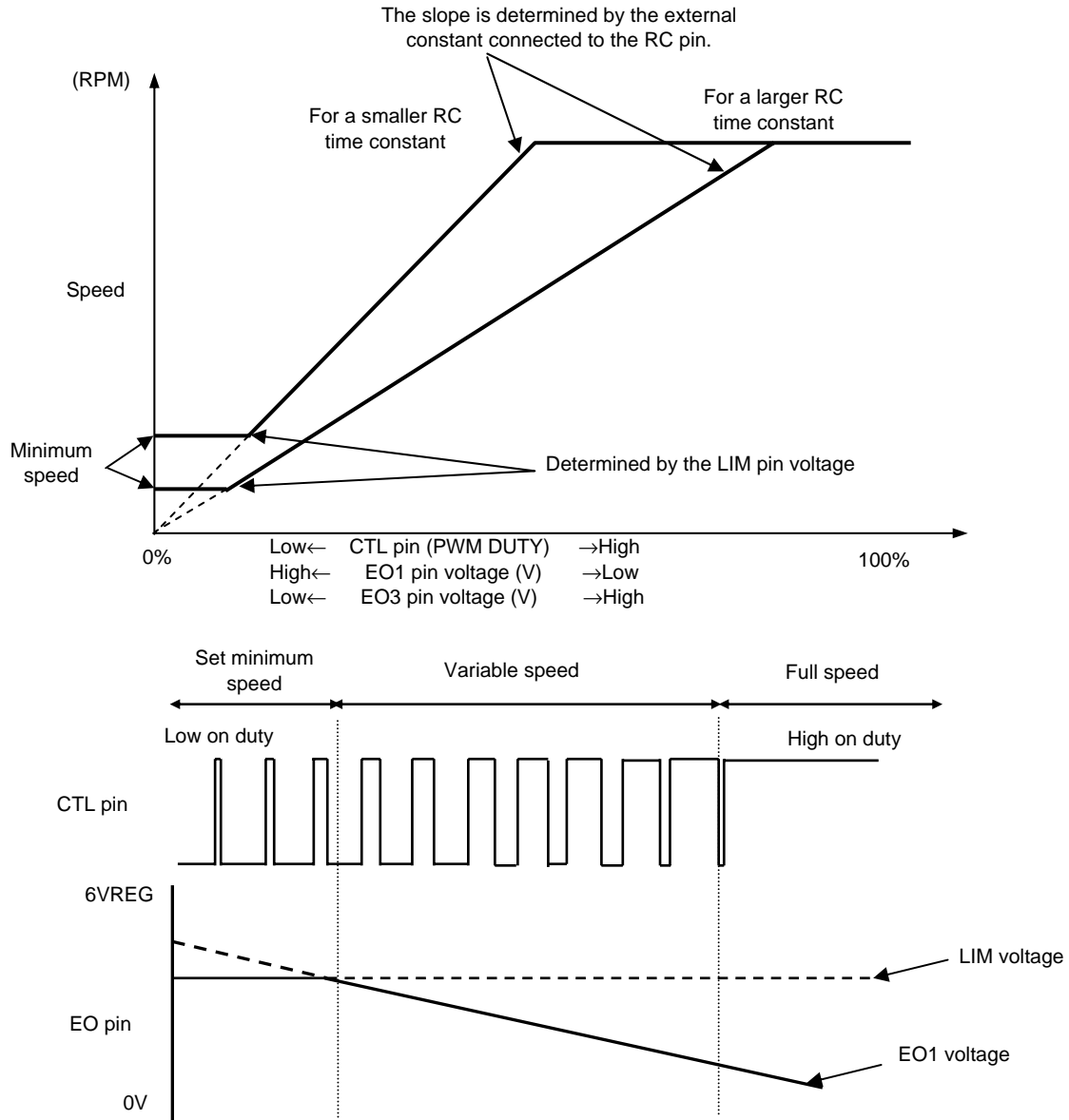

Startup Timing (soft start)

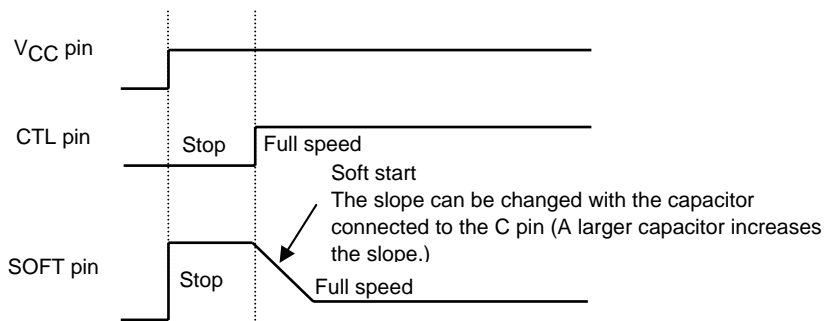

LB8503V

Supplementary Operational Descriptions

The LB8503V accepts a duty pulse input and an FG signal from the driver IC, and generates the driver IC control voltage so that the FG period (motor speed) becomes proportional to the control voltage.

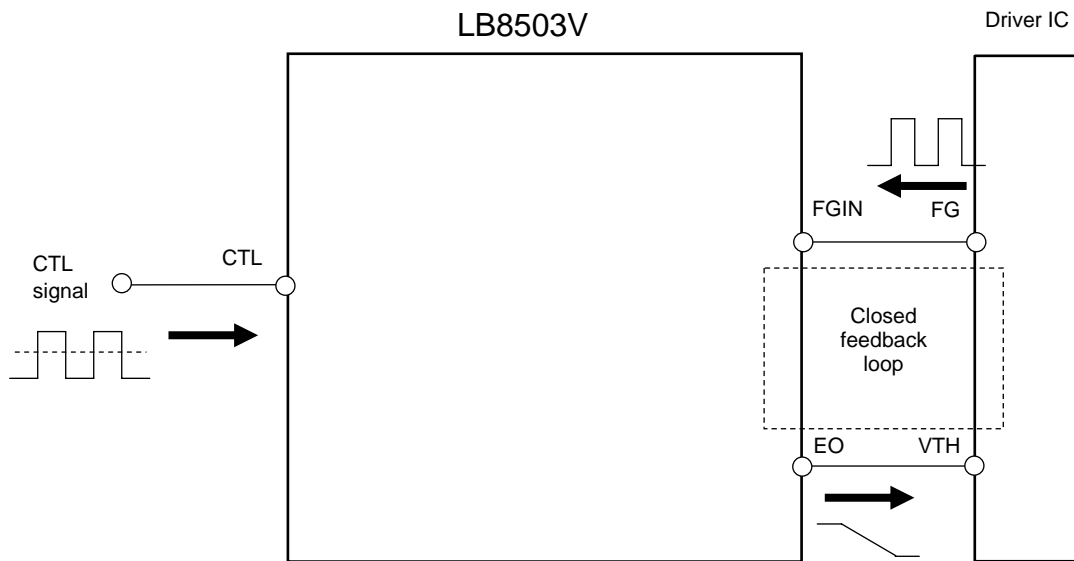

As shown in the figure below, the LB8503V generates a pulse signal from edges on the FG signal and then generates a pulse width waveform determined by the RC time constant in a one-shot multivibrator.

The LB8503V then integrates that pulse waveform to create the output driver IC control voltage (a DC voltage).

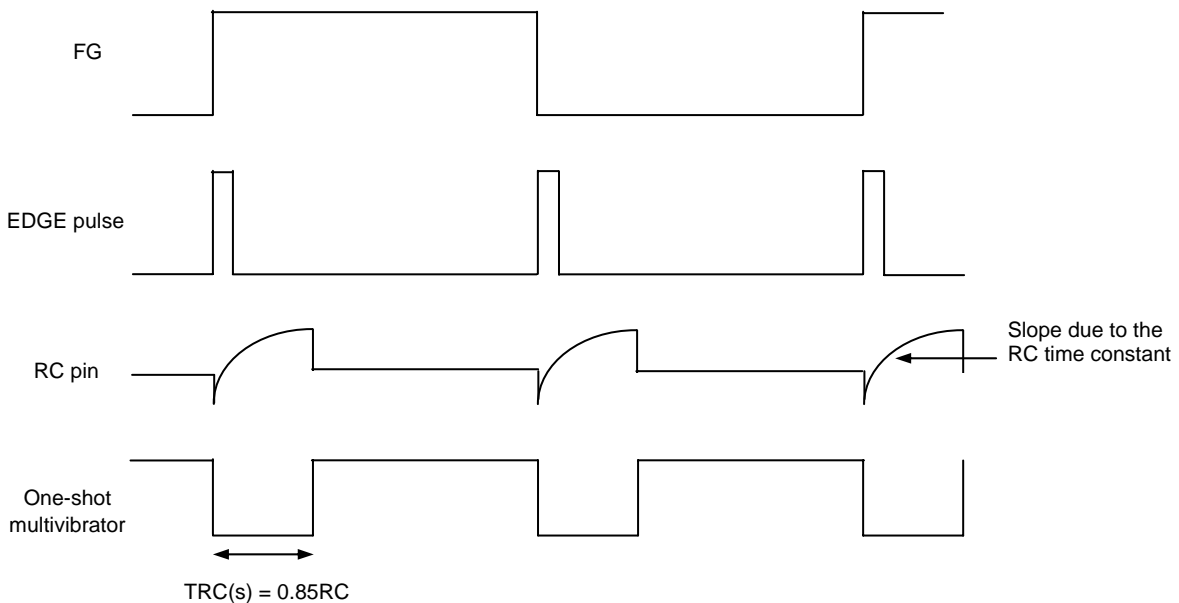

It is also possible to change the slope of the VCTL/speed relationship as shown in the speed control diagram in the previous section by changing the pulse width with the RC time constant.

Note, however, that since pulses determined by this RC time constant are used, variation in the RC components will appear as speed control errors.

Pin Setting Procedures (Provided for reference purposes)

[RC pin]

The slope in the speed control diagram is determined by the RC pin time constant.

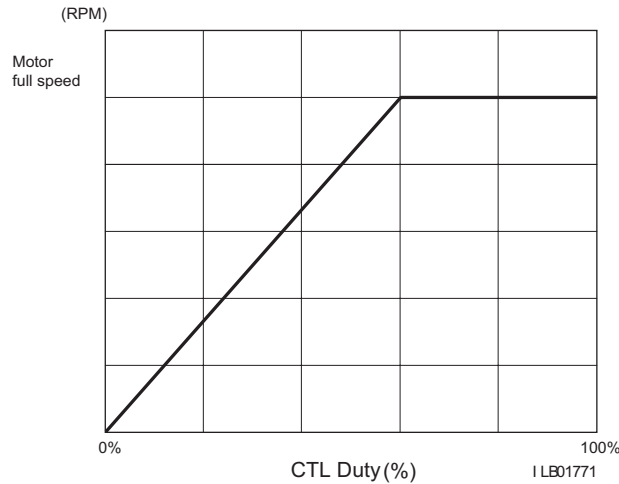

1. Determine the FG signal frequency (f_{FG} (Hz)) at the motor's highest speed.
 (When 2 FG pulses are created on each motor revolution.)
 $f_{FG}(\text{Hz}) = 2\text{rpm}/60 \dots\dots\dots(1)$

2. Determine the time constant for the RC pin.
 (Let DUTY be the control duty at the highest motor speed. For example, 100% = 1.0, 60% = 0.6)
 $R \times C = \text{DUTY} / (3 \times 0.85 \times f_{FG}) \dots\dots\dots(2)$

3. Determine the resistor and capacitor values
 The range of capacitors that can be used is from 0.01 to 0.015 μF due to the charge capabilities of the RC pin circuit. Therefore, an appropriate resistor value can be determined from either (3) or (4) below from the result obtained in step 2 above.
 $R = (R \times C) / 0.01 \mu\text{F} \dots\dots\dots(3)$
 $R = (R \times C) / 0.015 \mu\text{F} \dots\dots\dots(4)$

Note that the temperature characteristics of the curve are determined by the temperature characteristics of the capacitor connected to the RC pin.

A capacitor with excellent temperature characteristics must be used to minimize motor speed variation with temperature.

LB8503V

[CVO and CVI Pins]

These pins determine the origin of the slope. (To set the origin to 0% at 0 rpm, short CVO to CVI.)

1. X axis shift (Resistor dividing the CVO to ground potential)

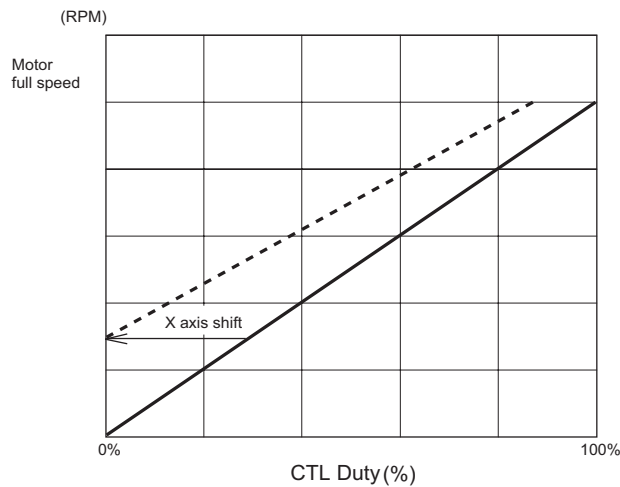

To shift the characteristics from a 0% = 0 rpm origin to a situation where the speed at a duty of 30% is shifted to 0%: First, determine the required CVI pin input voltage at 0%:

$$CVI = 6 - (4 \times DUTY) = 6 - (4 \times 0.3) = 6 - 1.2 = 4.8V$$

Next, when CVO is 6V, determine the resistor values for the resistor divider between CVO and ground such that the midpoint becomes 4.8V.

$$CVO - CVI : CVI - \text{ground} = 1.2V : 4.8V = \text{a ratio of } 1 : 4.$$

From the above, the desired resistor values will be 20kΩ between CVO and CVI and 80kΩ between CVI and ground. Note that the slope will change. (In this case, since the resistor ratio is 1:4, the result will be 4/5 of (or 0.8 times) the original slope.)

If required, the RC pin resistor value must be changed to correct the slope.

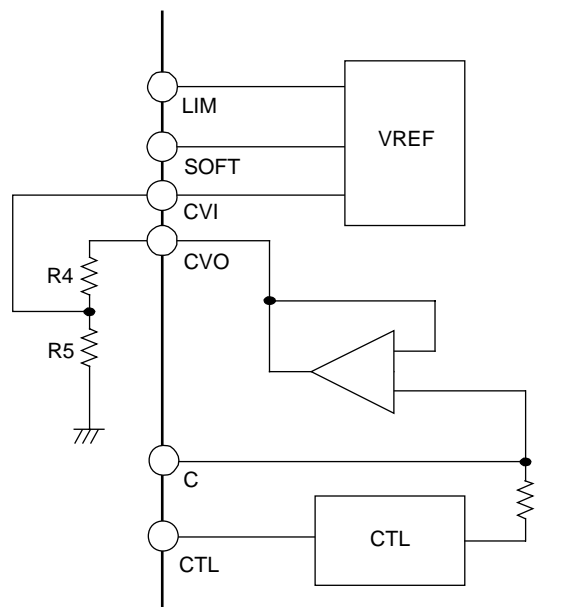

ILB01773

LB8503V

2. Y axis shift (Resistor dividing the CVO to V_{CC} potential)

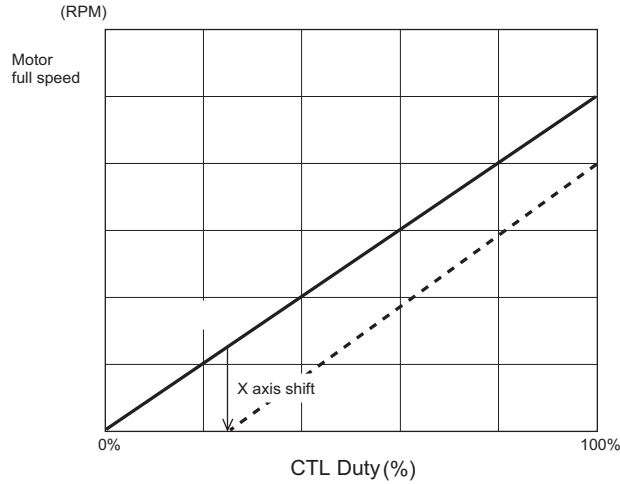

To shift the characteristics from a 0% = 0 rpm origin to a situation where the speed is 0 rpm at a duty of 30%:

First, determine the required CVO pin input voltage at 0%.

$$CVO = 6 - (4 \times DUTY) = 6 - (4 \times 0.25) = 6 - 1 = 5V$$

Determine the resistor values such that at CVO = 5 V, CVI becomes 6V.

$$CVO - CVI : CVI - V_{CC} = 1 V : 6V = \text{a ratio of } 1:6.$$

From the above, the desired resistor values will be 20kΩ between CVO and CVI and 80kΩ between CVI and ground.

(Due to the current capability of the CVO pin, the total resistor value must exceed 100kΩ.)

Note that the slope will change. (In this case, since the resistor ratio is 1:6, the result will be 6/7 of (or 0.86 times) the original slope.)

If required, the RC pin resistor value must be changed to correct the slope.

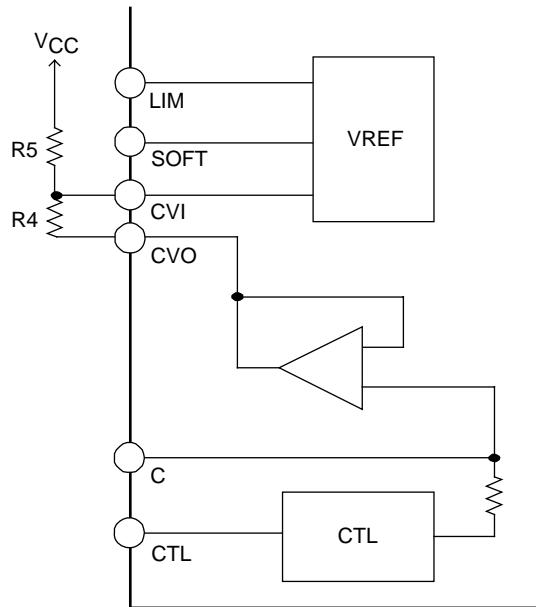

ILB01775

LB8503V

[LIM Pin]

The minimum speed is determined by the LIM pin voltage.

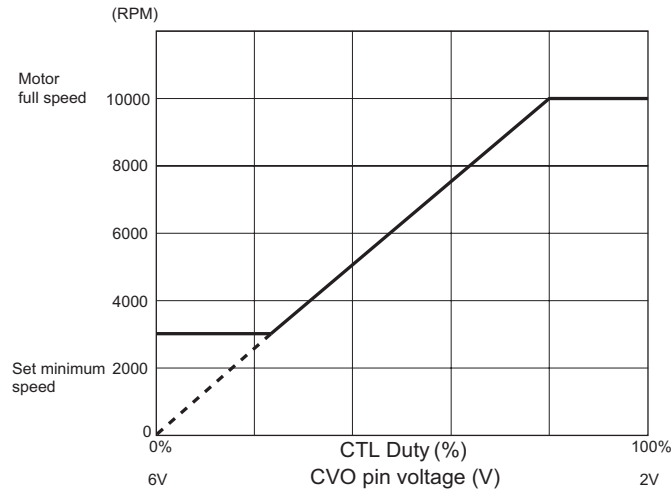

1. Determine the ratio of the required minimum speed and the maximum speed.
 $R_a = \text{minimum speed}/\text{maximum speed} \dots\dots\dots (1)$
 In the example in the figure above, $R_a = \text{minimum speed}/\text{maximum speed} = 3000/10000 = 0.3$

2. Determine the product of the duty that produces the maximum speed and the value from equation 1.
 $C_a = \text{maximum speed duty} \times R_a \dots\dots\dots (2)$
 For example, $C_a = \text{maximum speed duty} \times R_a = 0.8 \times 0.3 = 0.24$

3. Determine the required LIM pin voltage
 $LIM = 6 - (4 \times C_a) \dots\dots\dots (3)$
 For example, $LIM = 6 - (4 \times C_a) = 6 - (4 \times 0.24) \approx 5V$

4. Generate the LIM voltage by resistor dividing the 6 V regulator voltage.
 For example, the resistor ratio to create a 5V level will be 1:5.
 Thus the resistor values will be 10kΩ between 6VREG and LIM and 51kΩ between LIM and ground.

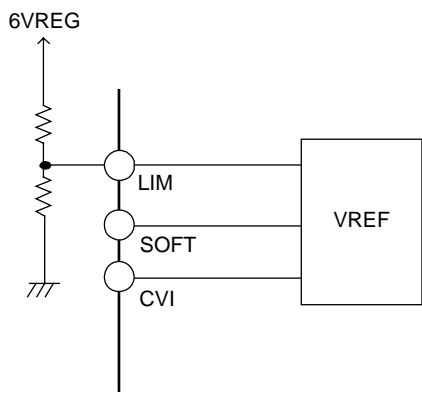

ILB01777

LB8503V

[C Pin]

Since a capacitor that can smooth the pin voltage is connected to the C pin, if the CTL pin input signal frequency is f (Hz), then the capacitor must meet the following condition. (Here, R is the IC internal resistance of 180Ω (typical).)

$$1/f = t < RC$$

Note that the larger the capacitor, the slower its response to changes in the input signal will be.

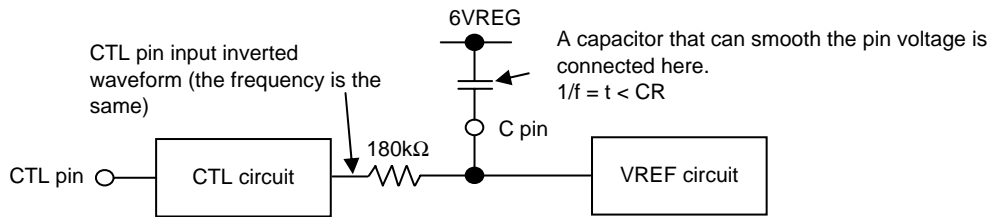

LB8503V

Application Example 2

[Setting the minimum speed for an origin of 0% = 0 rpm]

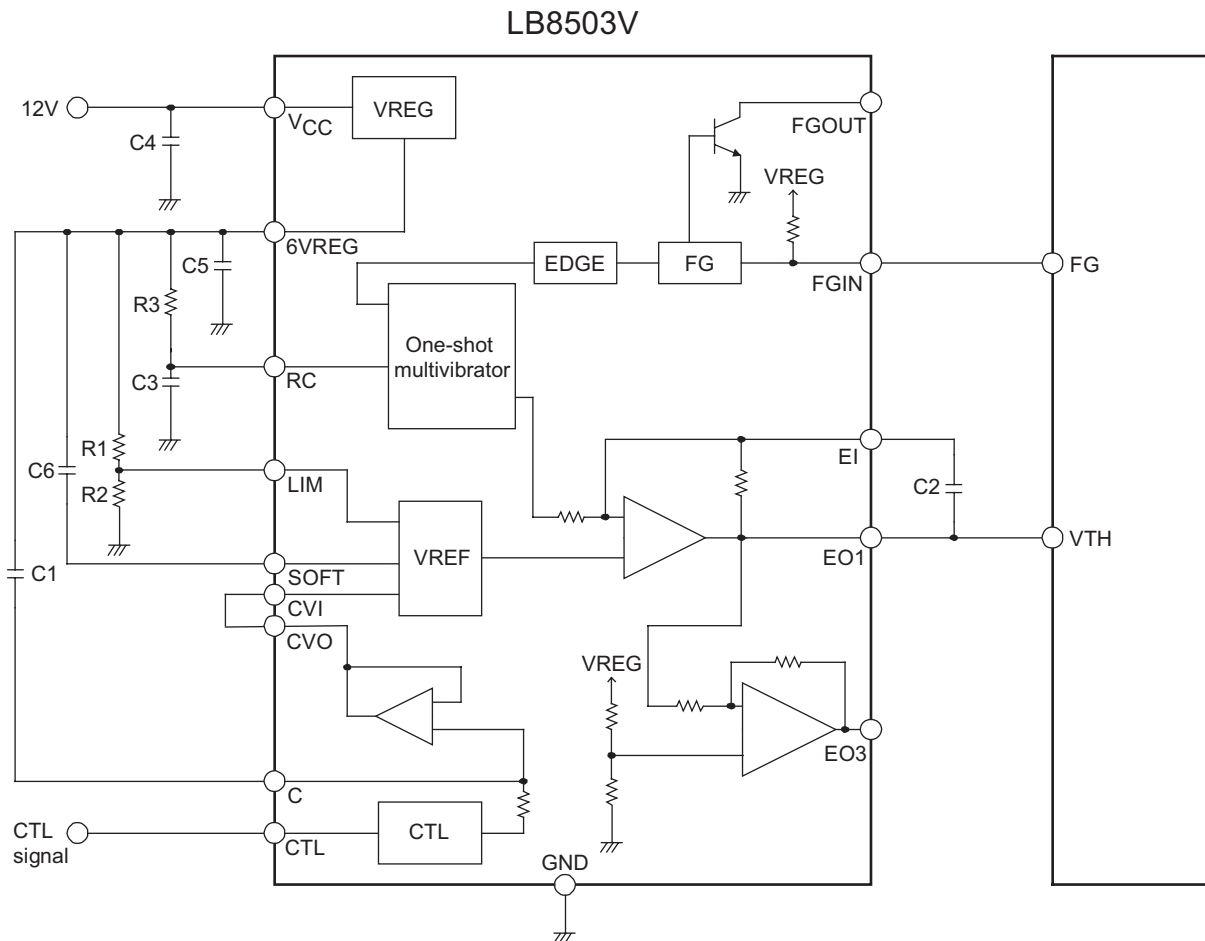
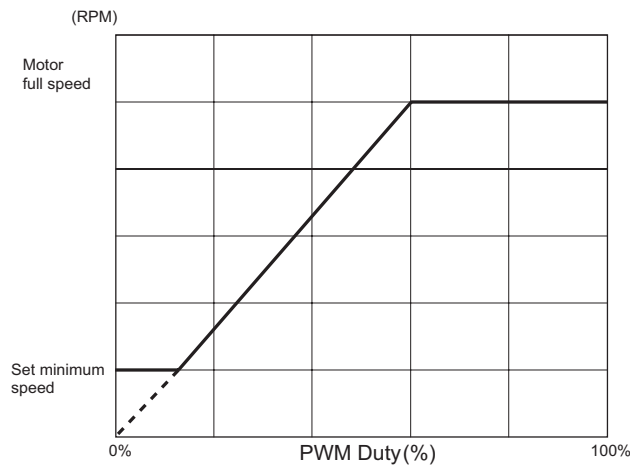

When the speed control diagram origin is 0% = 0 rpm, the CVO pin is connected to the CVI pin.
If the minimum speed is not set, connect the LIM pin to the 6VREG pin.

Application Example 3

[Origin shift in the Y direction (the motor turns at 0%)]

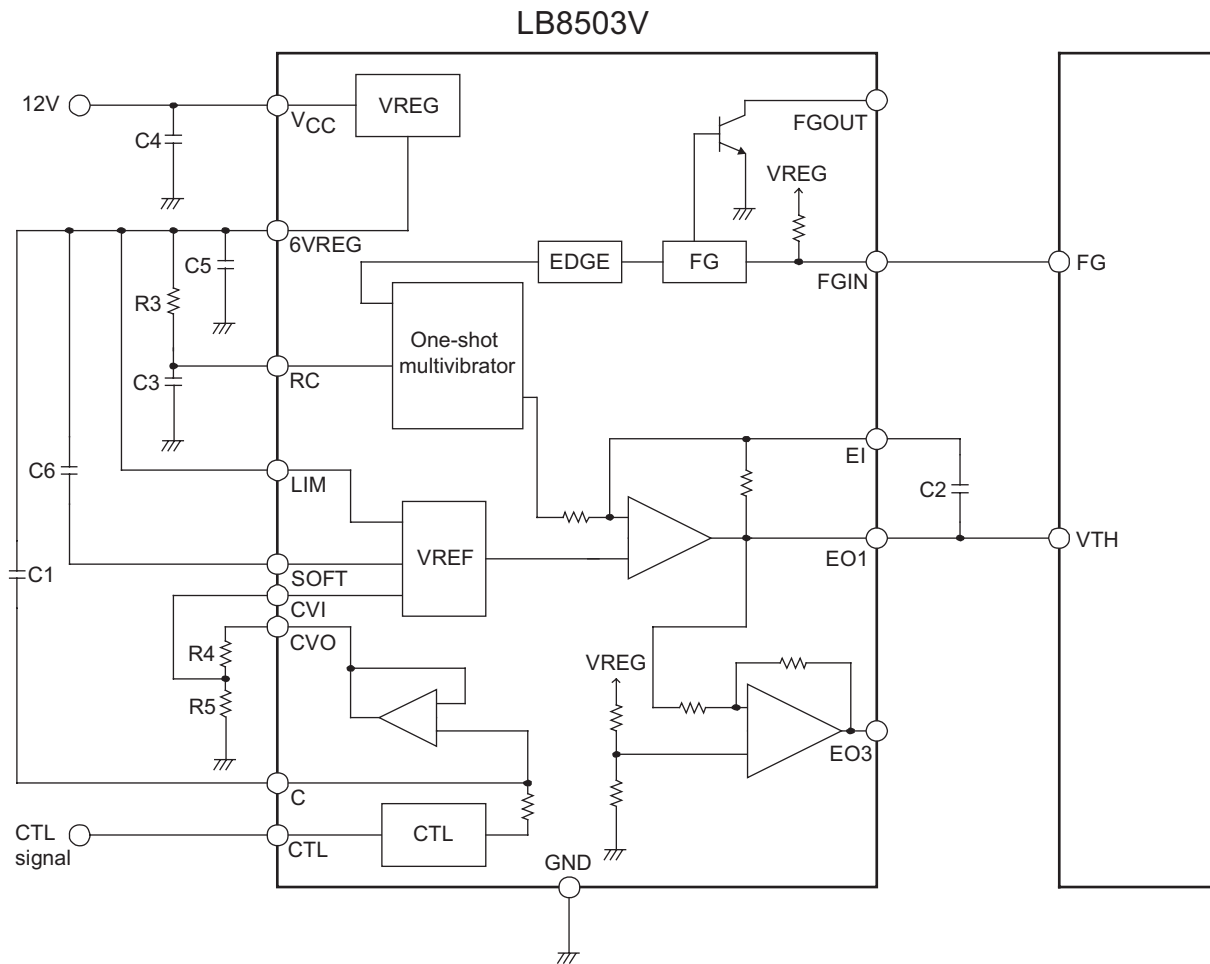
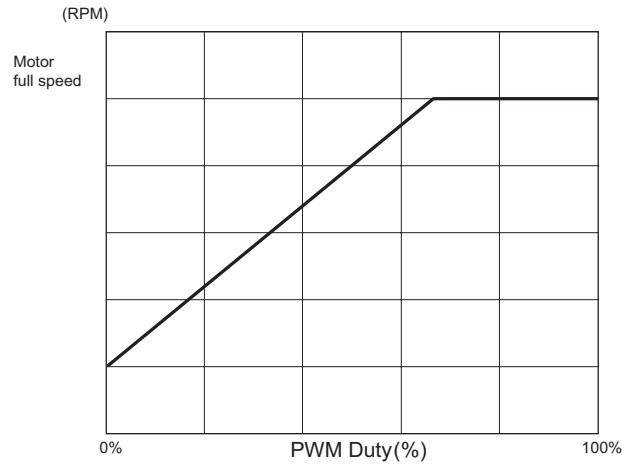

When the speed control diagram origin is set so the motor turns at 0%, the CVO pin to ground potential difference is resistor divided and the midpoint is input to the CVI pin. The speed at 0% can be changed with the resistor ratio.

LB8503V

Application Example 4

[Origin shift in the X axis direction (The motor turns at a duty of 10% or higher) plus a minimum speed setting]

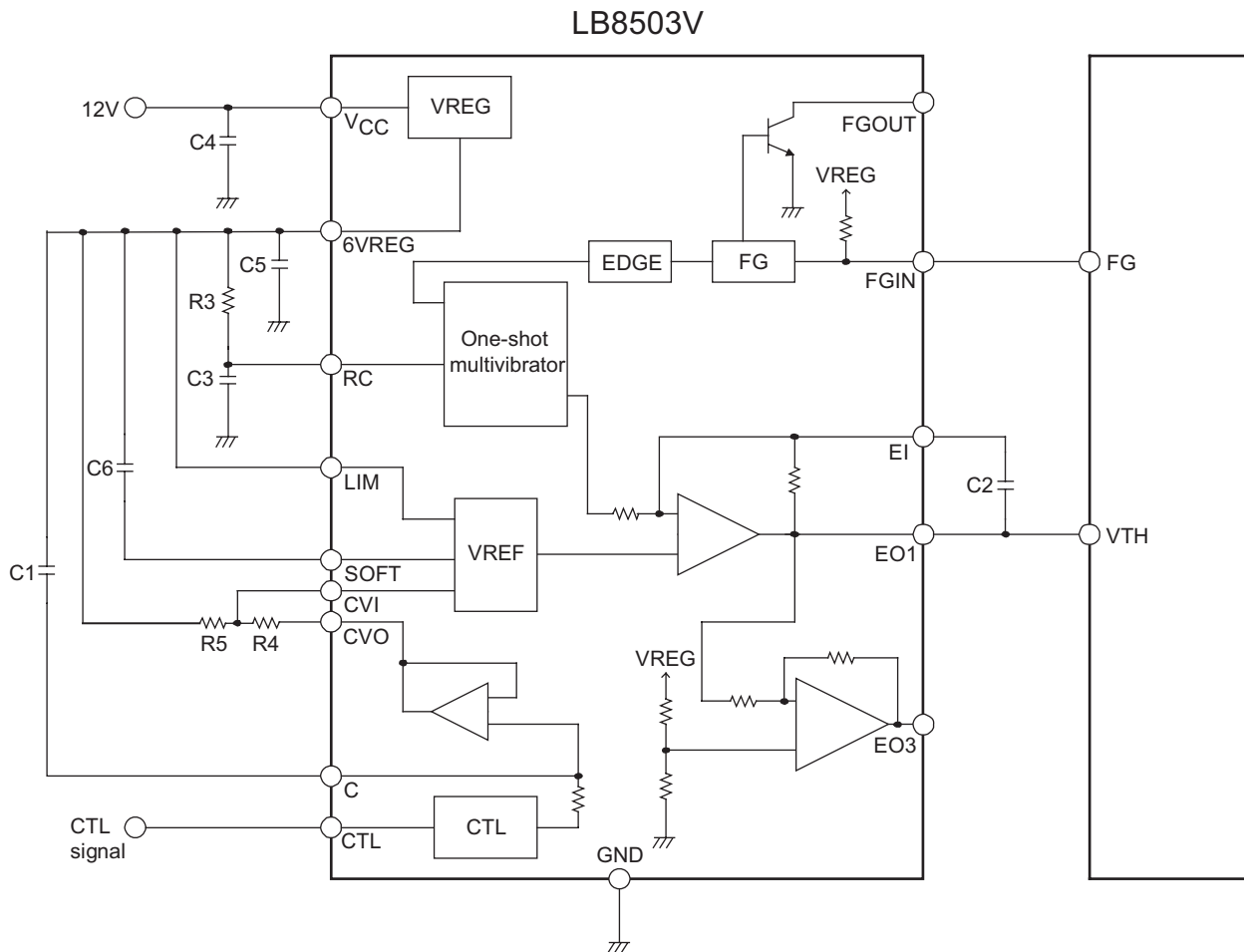
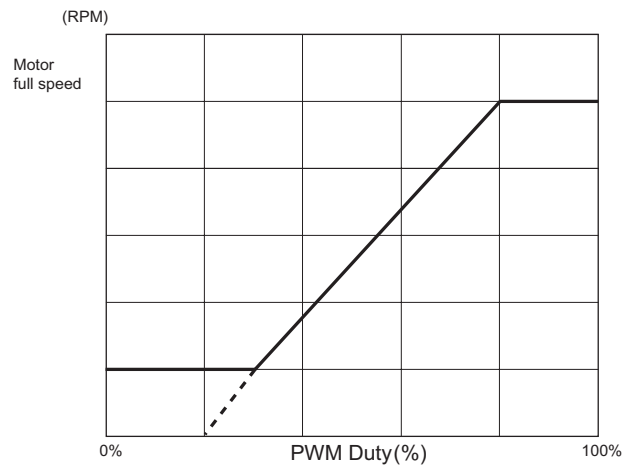

When the origin in the speed control diagram is set so that the motor starts turning when the duty is above 0%, the potential difference between the CVO pin and VCC is resistor divided, and that divided level is input to the CVI pin. The duty at which rotation starts can be changed by changing the resistor ratio. Note that the total value of the resistors R4 and R5 must exceed 100kΩ.

Application Example 5
[DC Voltage Speed Control]

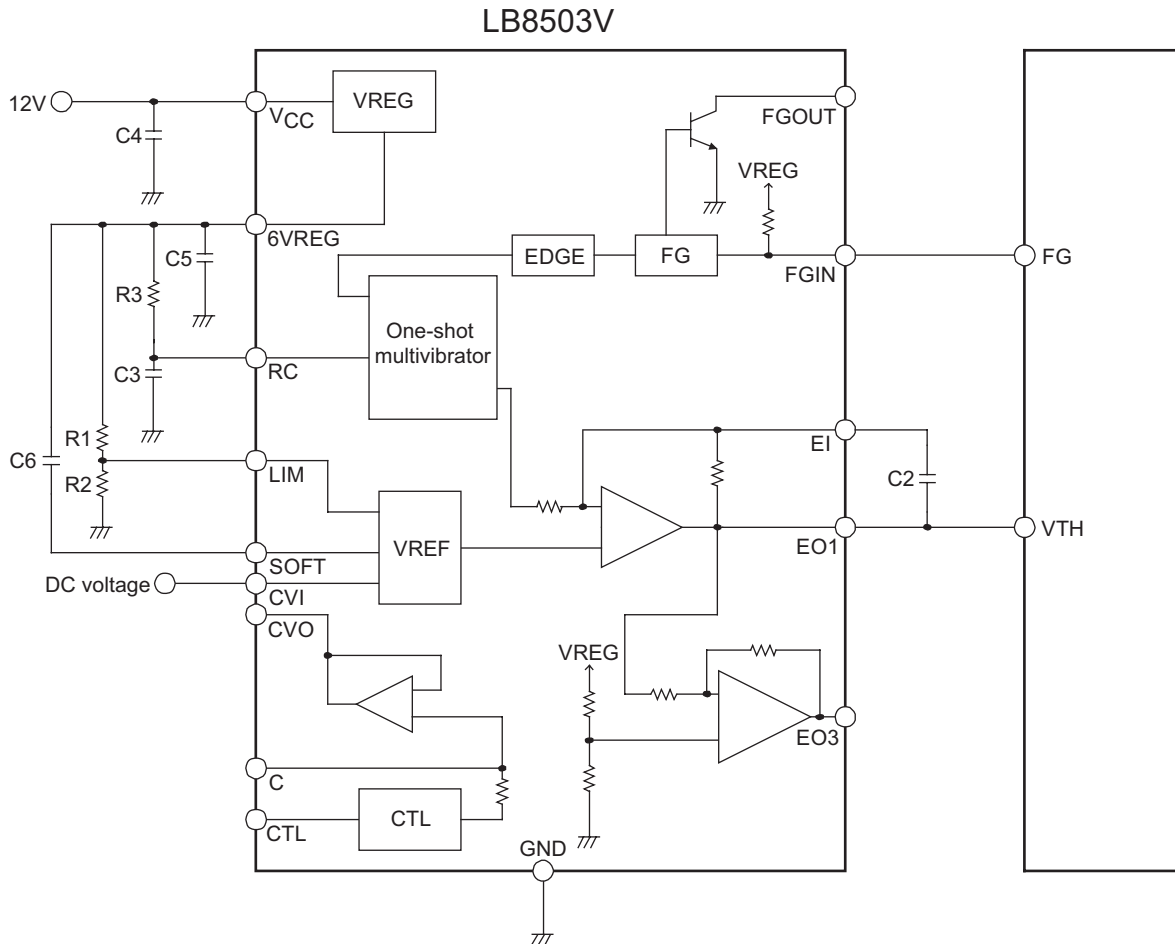
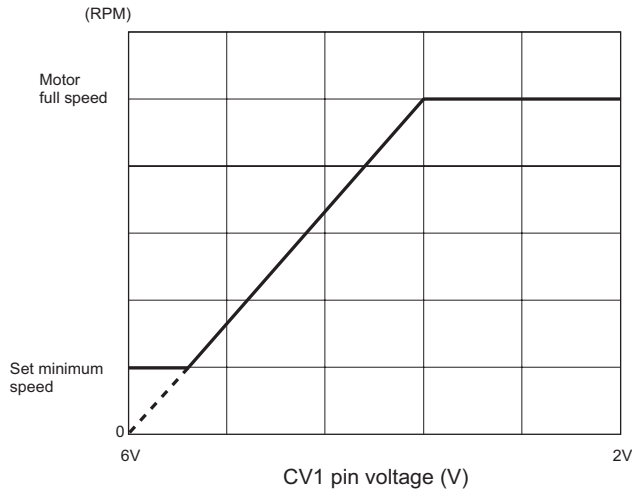

When the motor speed is controlled by a DC voltage, that voltage must be in the range from 2V to 6VREG. Note that the motor stops when the control voltage is at 6VREG, and the motor speed increases as the voltage falls.

LB8503V

Application Example 6

[Fixed Speed + Soft Start]

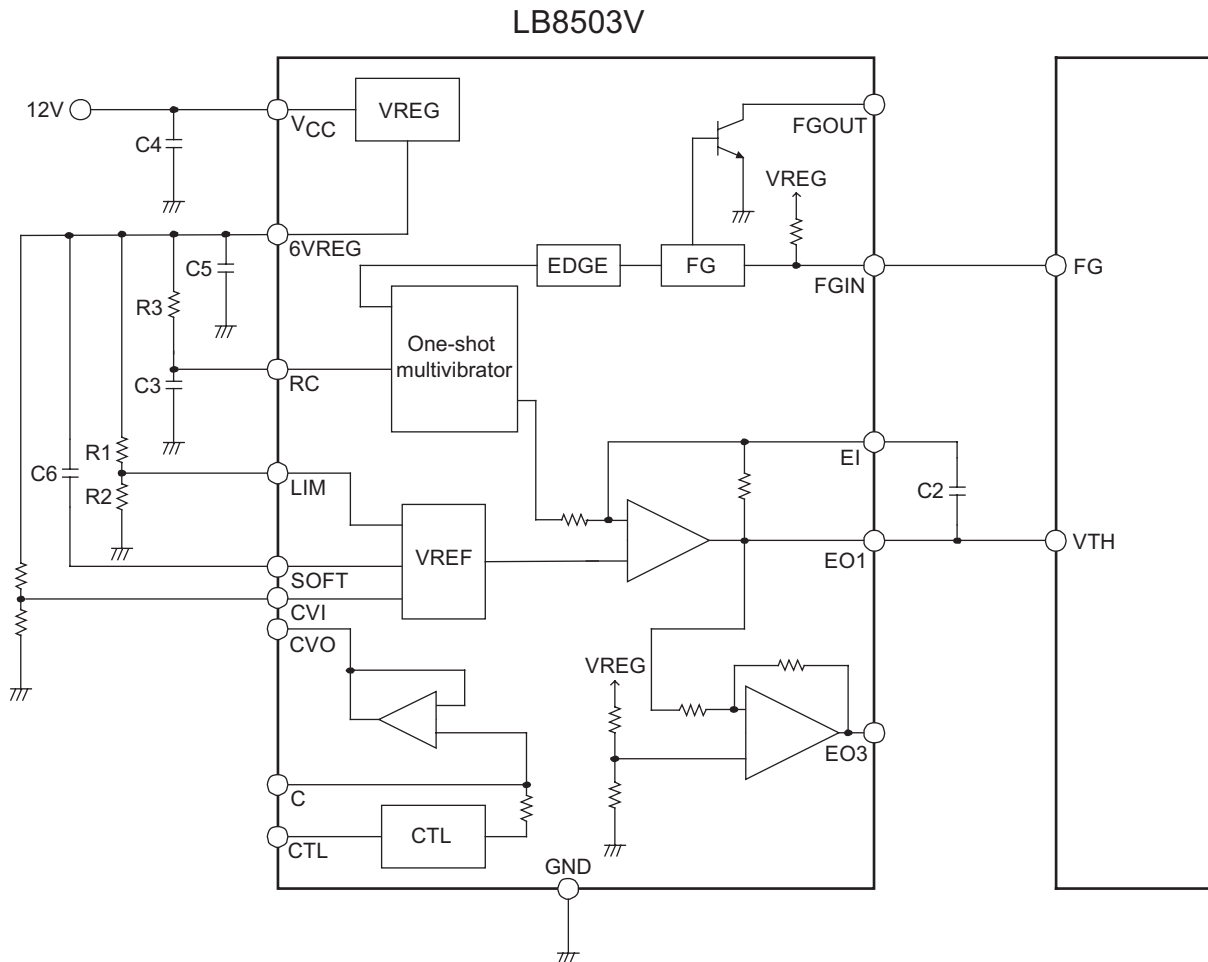
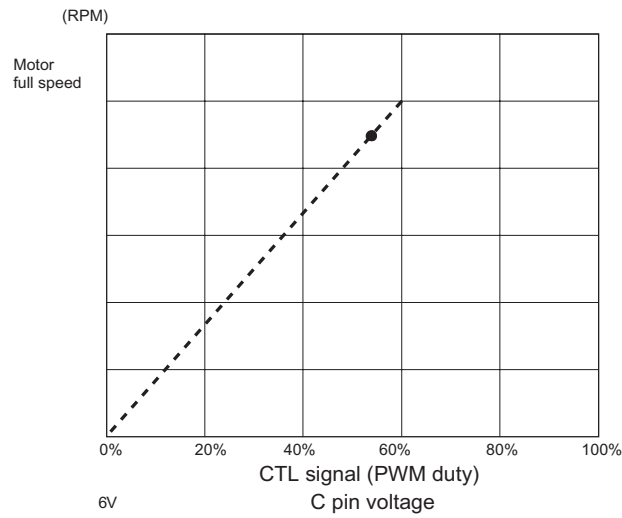

With this circuit, the motor speed remains constant even if there are fluctuations in the supply voltage or static voltage. It is also possible to input a fixed-duty signal to the CTL pin signal input as an input signal for which soft start is enabled at startup.

Application Example 7

[Used in Combination with the LB11660FV]

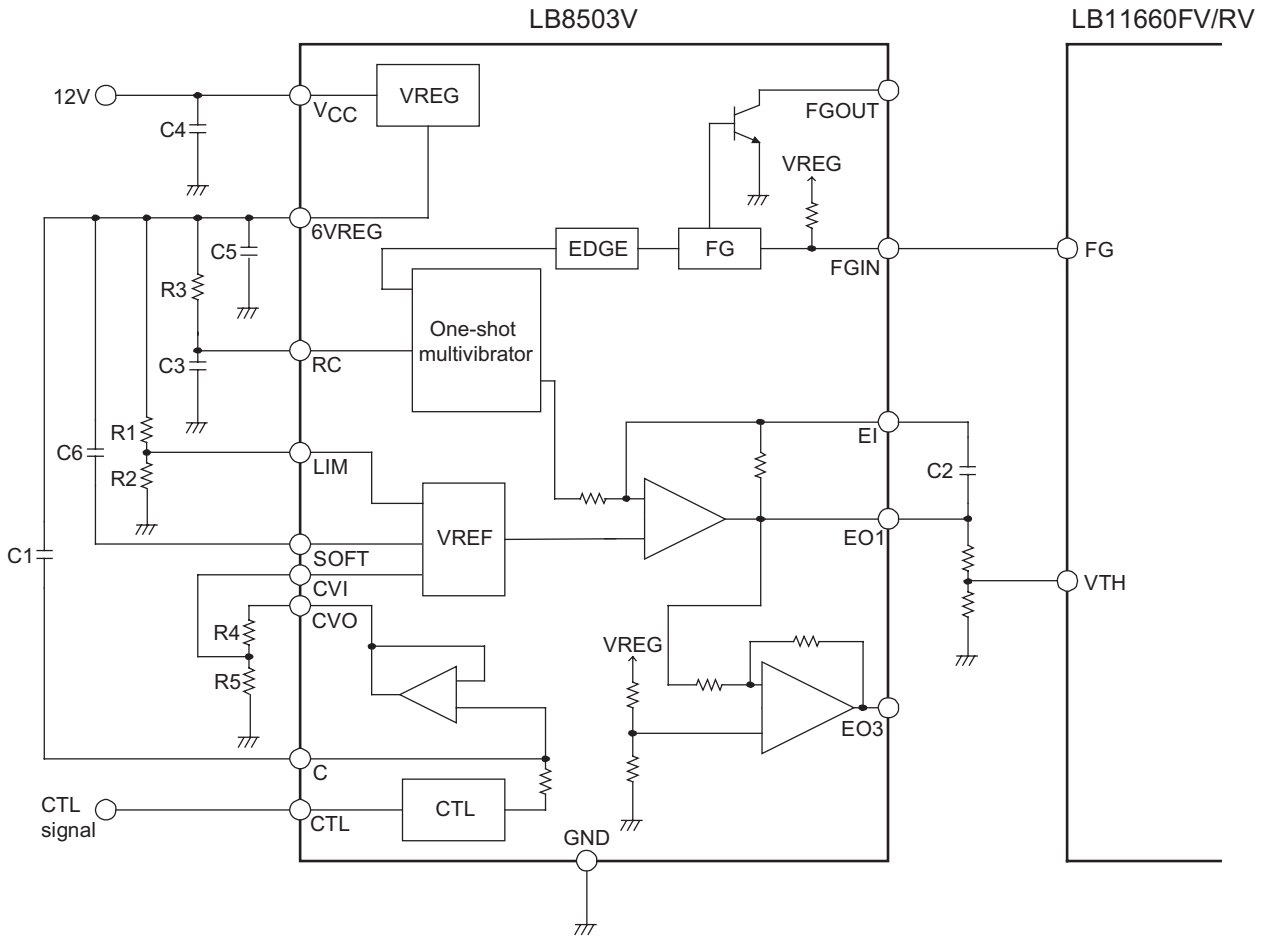

In this circuit, the dynamic range of the LB8503V EO pin (the range from the amplifier block output high to output low levels) must be wider than the dynamic range (from the high to low levels of the PWM signal) of VTH pin of driver IC with which this IC is combined.

However, since the LB11660FV PWM low-level voltage is lower than the LB8503V amplifier output low-level voltage, it must be resistor divided.

ON Semiconductor and the ON logo are registered trademarks of Semiconductor Components Industries, LLC (SCILLC). SCILLC owns the rights to a number of patents, trademarks, copyrights, trade secrets, and other intellectual property. A listing of SCILLC's product/patent coverage may be accessed at www.onsemi.com/site/pdf/Patent-Marking.pdf. SCILLC reserves the right to make changes without further notice to any products herein. SCILLC makes no warranty, representation or guarantee regarding the suitability of its products for any particular purpose, nor does SCILLC assume any liability arising out of the application or use of any product or circuit, and specifically disclaims any and all liability, including without limitation special, consequential or incidental damages. "Typical" parameters which may be provided in SCILLC data sheets and/or specifications can and do vary in different applications and actual performance may vary over time. All operating parameters, including "Typicals" must be validated for each customer application by customer's technical experts. SCILLC does not convey any license under its patent rights nor the rights of others. SCILLC products are not designed, intended, or authorized for use as components in systems intended for surgical implant into the body, or other applications intended to support or sustain life, or for any other application in which the failure of the SCILLC product could create a situation where personal injury or death may occur. Should Buyer purchase or use SCILLC products for any such unintended or unauthorized application, Buyer shall indemnify and hold SCILLC and its officers, employees, subsidiaries, affiliates, and distributors harmless against all claims, costs, damages, and expenses, and reasonable attorney fees arising out of, directly or indirectly, any claim of personal injury or death associated with such unintended or unauthorized use, even if such claim alleges that SCILLC was negligent regarding the design or manufacture of the part. SCILLC is an Equal Opportunity/Affirmative Action Employer. This literature is subject to all applicable copyright laws and is not for resale in any manner.