



ON Semiconductor®

<http://onsemi.com>

LB11961V

Monolithic Digital IC

Single-Phase Full-Wave Fan Motor Driver

Overview

The LB11961V is a single-phase bipolar drive motor driver that easily implements direct PWM motor drive systems with excellent efficiency. The LB11961V is optimal for fan motor drive in personal computer power supply systems and CPU cooling fan systems.

Features

- Single-phase full-wave drive (16V, 1.0A transistors are built in)
- Built-in variable speed function controlled by a thermistor input
The LB11961V can implement quiet, low-vibration variable speed control using externally clocked high side transistor direct PWM drive.
- Built-in regenerative diode (Di); only requires a minimal number of external components.
- Built-in HB
- Minimum speed setting pin (allows full-speed mode operation at startup)
- Operates in full-speed mode when the thermistor is removed.
- Built-in lock protection and automatic recovery circuits
- FG (speed detection) and RD (lock detection) outputs
- Built-in thermal shutdown circuit

LB11961V

Specifications

Absolute Maximum Ratings at $T_a = 25^\circ\text{C}$

Parameter	Symbol	Conditions	Ratings	Unit
V_{CC} maximum output voltage	$V_{CC\ max}$		18	V
OUT pin maximum output current	$I_{OUT\ max}$		1.0	A
OUT pin output withstand voltage	$V_{OUT\ max}$		18	V
HB maximum output current	$I_{HB\ max}$		10	mA
VTH input pin voltage	$V_{TH\ max}$		6	V
RD/FG output pin output voltage	$V_{RD/FG\ max}$		18	V
RD/FG maximum output current	$I_{RD/FG\ max}$		10	mA
Allowable power dissipation	$P_d\ max$	When mounted on a circuit board *1	0.8	W
Operating temperature	T_{opr}		-30 to +90	$^\circ\text{C}$
Storage temperature	T_{stg}		-55 to +150	$^\circ\text{C}$

*1 Specified circuit board : $114.3 \times 76.1 \times 1.6\text{mm}^3$, glass epoxy.

Caution 1) Absolute maximum ratings represent the value which cannot be exceeded for any length of time.

Caution 2) Even when the device is used within the range of absolute maximum ratings, as a result of continuous usage under high temperature, high current, high voltage, or drastic temperature change, the reliability of the IC may be degraded. Please contact us for the further details.

Stresses exceeding Maximum Ratings may damage the device. Maximum Ratings are stress ratings only. Functional operation above the Recommended Operating Conditions is not implied. Extended exposure to stresses above the Recommended Operating Conditions may affect device reliability.

Recommended Operating Conditions at $T_a = 25^\circ\text{C}$

Parameter	Symbol	Conditions	Ratings	Unit
V_{CC} supply voltage	V_{CC}		4.5 to 16	V
VTH input level voltage range	VTH		0 to 9	V
Hall sensor input common-mode input voltage range	VICM		0.2 to 3	V

Electrical Characteristics Unless otherwise specified $T_a = 25^\circ\text{C}$, $V_{CC} = 12\text{V}$

Parameter	Symbol	Conditions	Ratings			Unit
			min	typ	max	
Circuit current	I_{CC1}	Drive mode	12	18	24	mA
	I_{CC2}	Lock protection mode	8	11	16	mA
6VREG voltage	V_{6VREG}	$I_{6VREG} = 5\text{mA}$	5.8	6	6.2	V
HB voltage	VHB	$I_{HB} = 5\text{mA}$	1.10	1.25	1.40	V
CPWM high-level voltage	VCRH		3.45	3.6	3.75	V
CPWM low-level voltage	VCRL		1.95	2.05	2.15	V
CPWM oscillator frequency	FPWM	$C = 100\text{pF}$	18	25	32	kHz
CT pin high-level voltage	VCTH		3.45	3.6	3.75	V
CT pin low-level voltage	VCTL		1.55	1.7	1.85	V
ICT charge current	ICT1		1.5	2	2.5	μA
ICT discharge current	ICT2		0.15	0.2	0.25	μA
ICT charge/discharge current ratio	RCT		8.5	10	11.5	
OUT output low saturation voltage	V_{OL}	$I_O = 200\text{mA}$		0.2	0.3	V
OUT output high saturation voltage	V_{OH}	$I_O = 200\text{mA}$		0.9	1.1	V
Hall sensor input sensitivity	VHN	Zero peak value (including offset and hysteresis)		10	20	mV
RD/FG output pin low-level voltage	$V_{RD/FGL}$	$V_{RD/FG} = 5\text{mA}$		0.2	0.3	V
RD/FG output pin leakage current	$I_{RD/FGL}$	$V_{RD/FG} = 7\text{V}$			30	μA

LB11961V

Package Dimensions

unit : mm (typ)

3178B

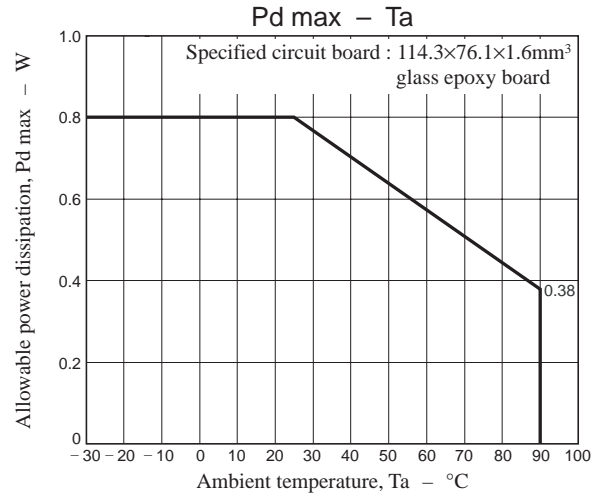
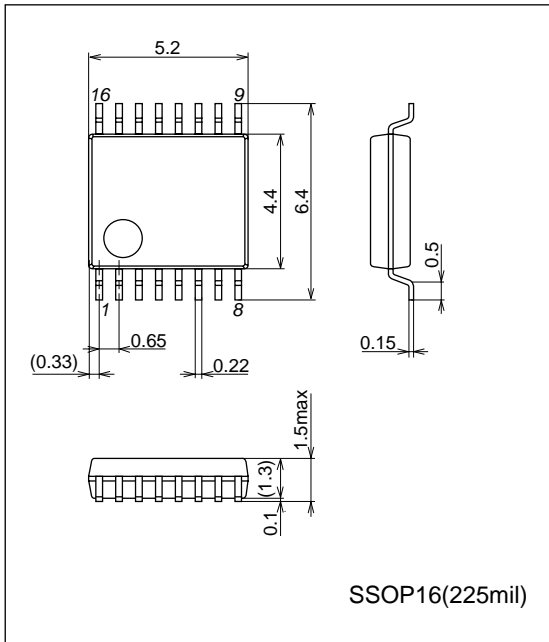

Truth Table

VTH	IN-	IN+	CPWM	CT	OUT1	OUT2	FG	RD	Mode
Low (open)	High	Low	High	Low	High	Low	Low	On	During rotation - drive (PWM off)
	Low	High			Low	High	Off		
High	High	Low	Low		Off	Low	Low	Off	During rotation - regeneration (PWM on)
	Low	High			Low	Off	Off		
-	High	Low	-	High	High	Off	Low	Off	Lock protection
-	Low	High	-		Off	High	Off		

CPWM - High is the state where CPWM > VTH, and CPWM - Low is the state where CPWM < VTH.

Open : The LB11961V operates in full-speed mode when the thermistor is removed.

Pin Assignment

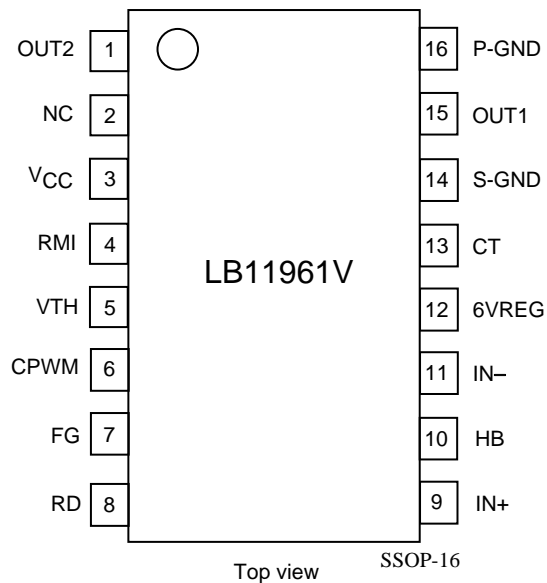

P-GND : Motor system ground

S-GND : Control system ground

LB11961V

Block Diagram

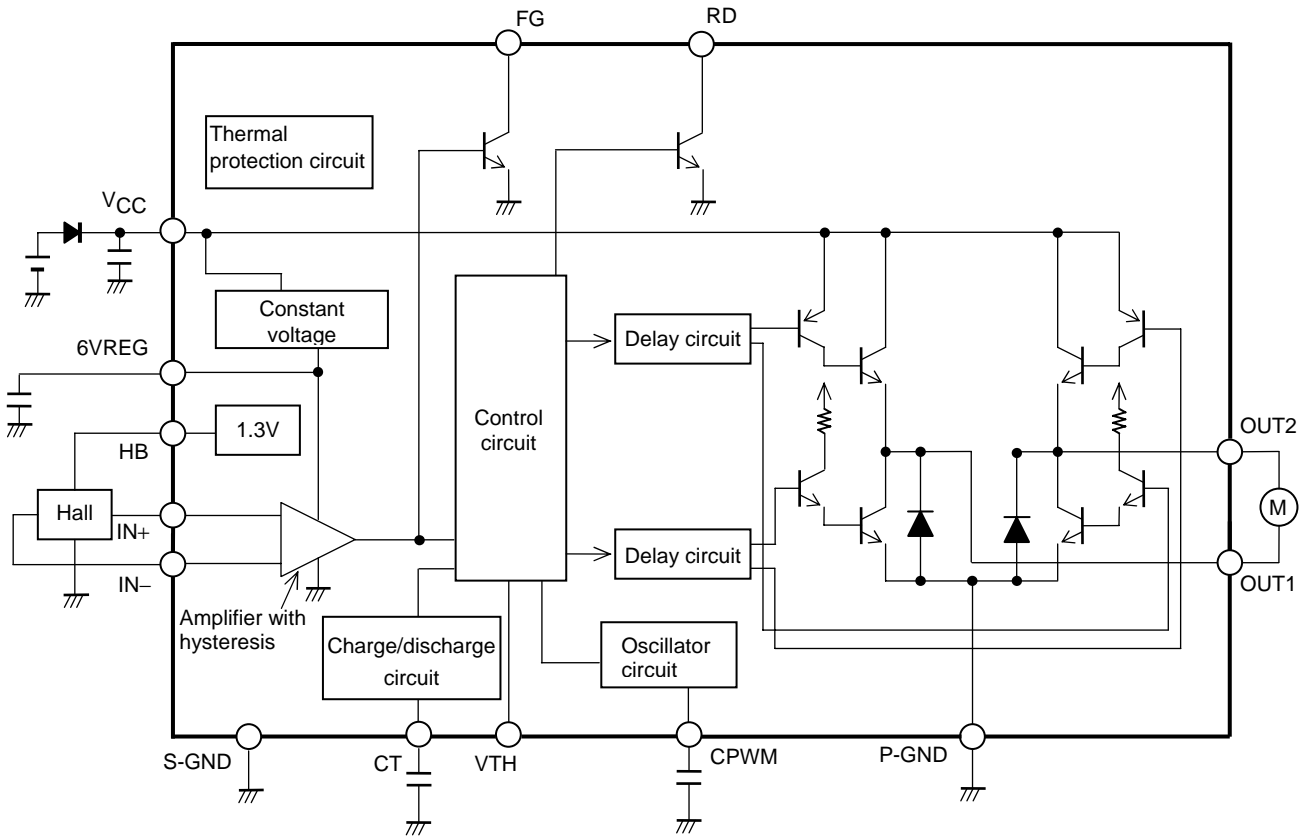

Application Circuit Example

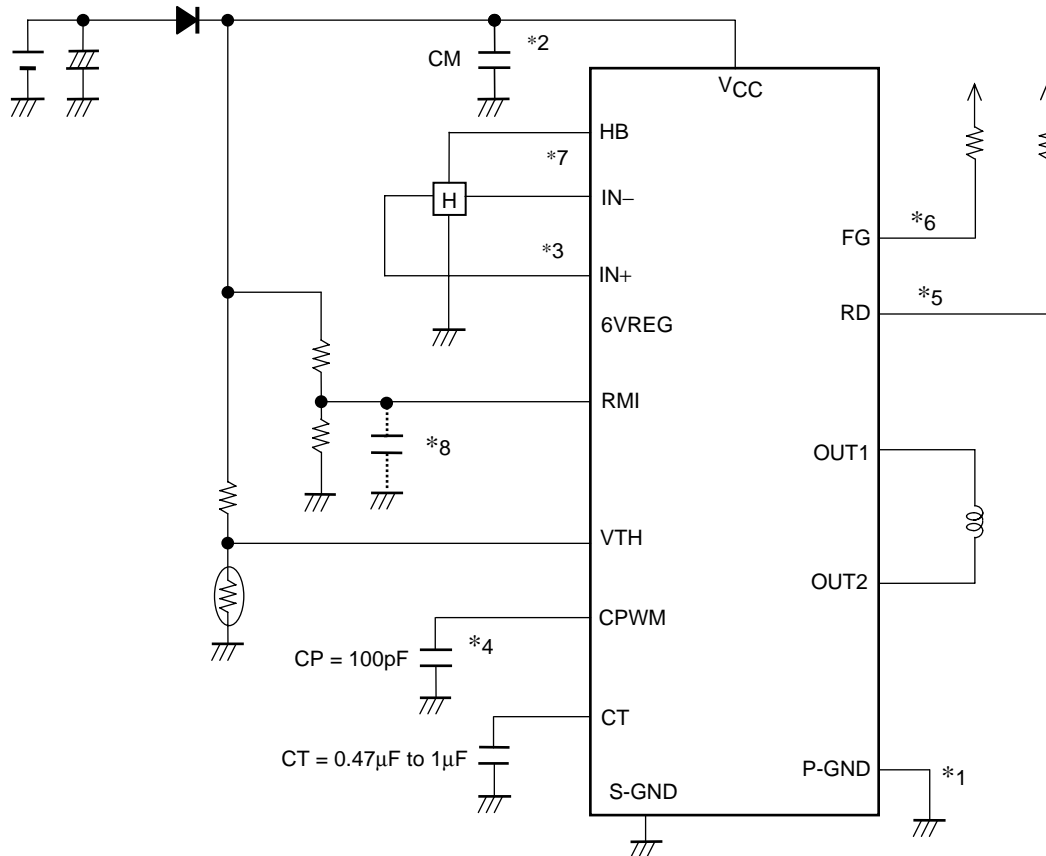

***1. Power supply and ground lines**

P-GND is connected to the motor power supply system and S-GND is connected to the control circuit power supply system. These two systems should be formed from separate lines and the control system external components should be connected to S-GND.

***2. Regeneration power supply stabilization capacitor**

The capacitor CM provides power supply stabilization for both PWM drive and kickback absorption. A capacitor with a value of over 0.1μF is used for CM. A large capacitor must be used when the coil inductance is large or when the coil resistance is low. Since this IC adopts a technique in which switching is performed by the high side transistor and regeneration is handled by the low side transistor, the pattern connecting CM to VM and P-GND must be as wide and as short as possible.

***3. Hall sensor input**

Lines that are as short as possible must be used to prevent noise from entering the system. The Hall sensor input circuit consists of a comparator with hysteresis (20mV). We recommend that the Hall sensor input level be at least three times this hysteresis, i.e. at least 60mVp-p.

***4. PWM oscillator frequency setting capacitor**

If a value of 100pF is used for CP, the oscillator frequency will be $f = 25\text{kHz}$, and this will be the basic frequency of the PWM signal.

***5. RD output**

This is an open collector output. It outputs a low level when the motor is turning and a high level when it is stopped. This pin must be left open if unused.

***6. FG output**

This is an open collector output, and a rotation count detection function can be implemented using this FG output, which corresponds to the phase switching. This pin must be left open if unused.

***7. HB pin**

This pin provides a Hall effect sensor bias constant-voltage output of 1.25V.

***8. RMI pin**

Connect this pin to VTH if unused. Even if unused, the IC is set internally to operate at a 10% drive duty at the voltage corresponding to the lowest speed. (The capacitor is used to set up full-speed mode at startup.)

Control Timing Chart

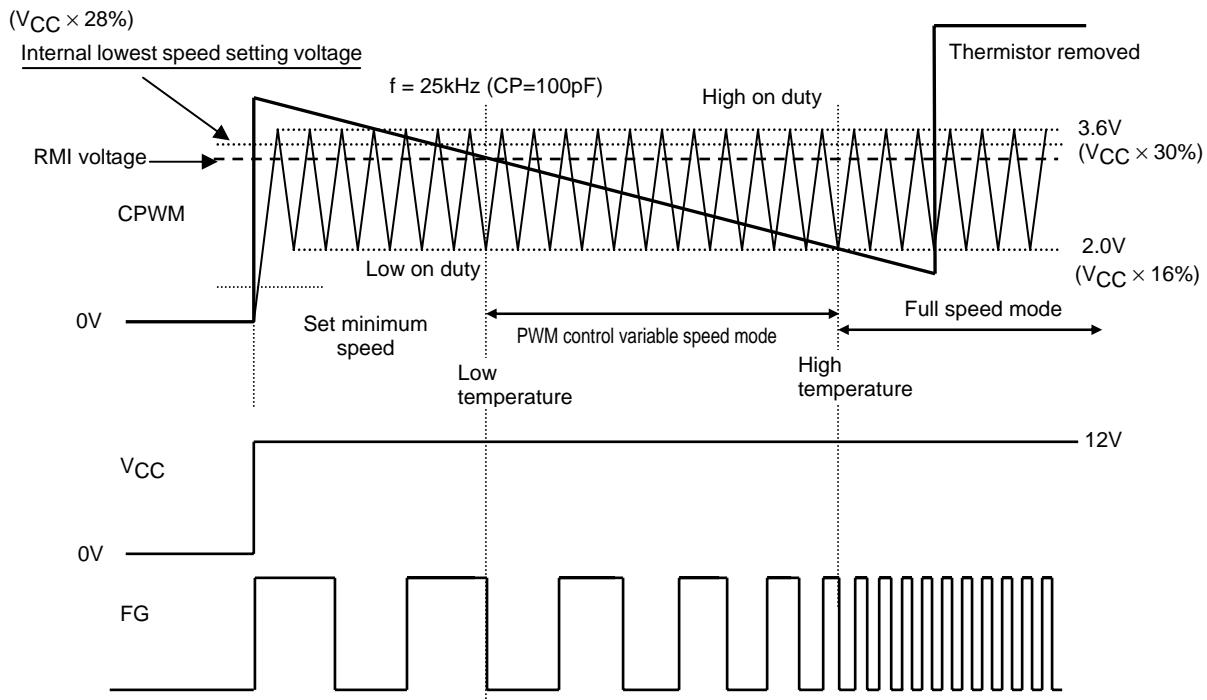

1. **Set minimum speed mode**

A VTH voltage level is generated when the thermistor detects the set temperature. At low temperatures, the fan motor turns at the lowest speed, which is set with the RMI pin. The LB11961V compares the CPWM oscillator voltage with the RMI pin voltage and sets the duty for the lowest drive state.

2. **High speed ↔ low speed mode**

The PWM signal is controlled by comparing the CPWM oscillation voltage that cycles between 1.2V and 3.8V and the VTH voltage.

When the VTH voltage is lower, the high and low side transistors are turned on, and when the VTH voltage is higher, the high side transistor is turned off and the coil current is regenerated through the low side transistor. Thus the output on duty increases as the VTH voltage becomes lower, the coil current increases, and the motor speed increases.

Rotation speed feedback is provided by the FG output.

3. **Full-speed mode**

The LB11961V switches to full-speed mode above a certain temperature.

4. **Thermistor removed mode**

If the thermistor is removed, the VTH input voltage will rise. However, the output will go to full drive at 100% and the motor will run at full speed.

ON Semiconductor and the ON logo are registered trademarks of Semiconductor Components Industries, LLC (SCILLC). SCILLC owns the rights to a number of patents, trademarks, copyrights, trade secrets, and other intellectual property. A listing of SCILLC's product/patent coverage may be accessed at www.onsemi.com/site/pdf/Patent-Marking.pdf. SCILLC reserves the right to make changes without further notice to any products herein. SCILLC makes no warranty, representation or guarantee regarding the suitability of its products for any particular purpose, nor does SCILLC assume any liability arising out of the application or use of any product or circuit, and specifically disclaims any and all liability, including without limitation special, consequential or incidental damages. "Typical" parameters which may be provided in SCILLC data sheets and/or specifications can and do vary in different applications and actual performance may vary over time. All operating parameters, including "Typicals" must be validated for each customer application by customer's technical experts. SCILLC does not convey any license under its patent rights nor the rights of others. SCILLC products are not designed, intended, or authorized for use as components in systems intended for surgical implant into the body, or other applications intended to support or sustain life, or for any other application in which the failure of the SCILLC product could create a situation where personal injury or death may occur. Should Buyer purchase or use SCILLC products for any such unintended or unauthorized application, Buyer shall indemnify and hold SCILLC and its officers, employees, subsidiaries, affiliates, and distributors harmless against all claims, costs, damages, and expenses, and reasonable attorney fees arising out of, directly or indirectly, any claim of personal injury or death associated with such unintended or unauthorized use, even if such claim alleges that SCILLC was negligent regarding the design or manufacture of the part. SCILLC is an Equal Opportunity/Affirmative Action Employer. This literature is subject to all applicable copyright laws and is not for resale in any manner.