

FAN8082 (KA3082N)

Bi-directional DC Motor Driver

Features

- Built-in brake function for stable brake characteristics.
- Built-in element to absorb a surge current derived from changing motor direction and braking motor drive.
- Motor speed control by an external voltage.
- Stable motor direction change.
- Interfaces with CMOS devices.
- Built-in the thermal shut down circuit (165°C).
- Low standby current. (6.5mA)

Description

The FAN8082 is a monolithic integrated circuit designed for driving bi-directional DC motor with braking and speed control, and it is suitable for the loading motor driver of VCR, CDP, and TOY systems. The speed control can be achieved by adjusting the external voltage of the speed control pin. It has two pins of logic inputs for controlling the forward/reverse and braking.

8-DIP-300



2

Typical Applications

- Compact disk player (CDP) tray or changer
- Low current DC motor such as audio or video equipment.
- General DC motor

Ordering Information

Device	Package	Operating Temp.
FAN8082	8-DIP-300	-25°C ~ +75°C

Pin Assignments

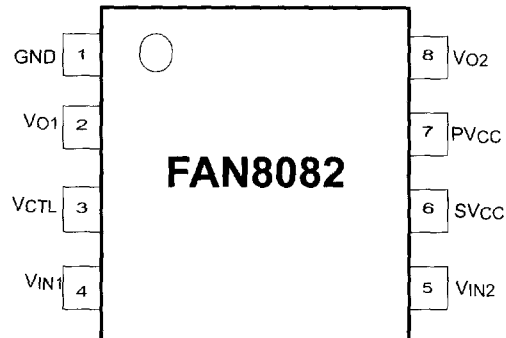

Pin Definitions

Pin Number	Pin Name	I/O	Pin Function Description
1	GND	-	Ground
2	VO1	O	Output 1
3	VCTL	I	Motor speed control
4	VIN1	I	Input 1
5	VIN2	I	Input 2
6	SVCC	-	Supply voltage (Signal)
7	PVCC	-	Supply voltage (Power)
8	VO2	O	Output 2

Internal Block Diagram

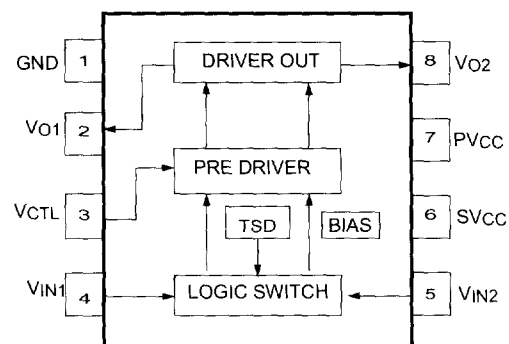

Equivalent Circuit

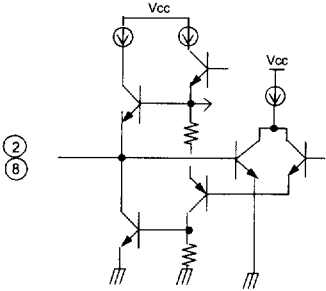
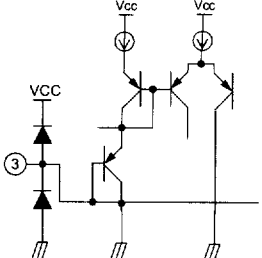
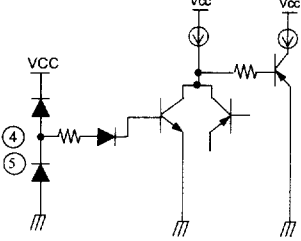
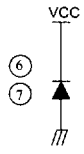
Description	Pin No.	Internal circuit
Output	2, 8	
Speed control	3	
Input	4, 5	
SVCC PVCC	6 7	

2

Absolute Maximum Ratings (Ta = 25°C)

Parameter	Symbol	Value	Unit	Remark
Supply voltage	VCCmax	18	V	-
Maxium Output current	IOmax	1.6 ^{note1}	A	-
Power dissipation	Pd	1.0 ^{note2}	W	-
Operating temperature	TOPR	-25 ~ +75	°C	-
Storage temperature	TSTG	-55 ~ +125	°C	-

NOTES:

- Duty 1 / 100, pulse width 500μs
- 1) When mounted on glass epoxy PCB (76.2 × 114 × 1.57mm)
- 2) Power dissipation reduces 9.6mW / °C for using above Ta=25°C.
- 3) Do not exceed Pd and SOA(Safe Operating Area).

Power Dissipation Curve

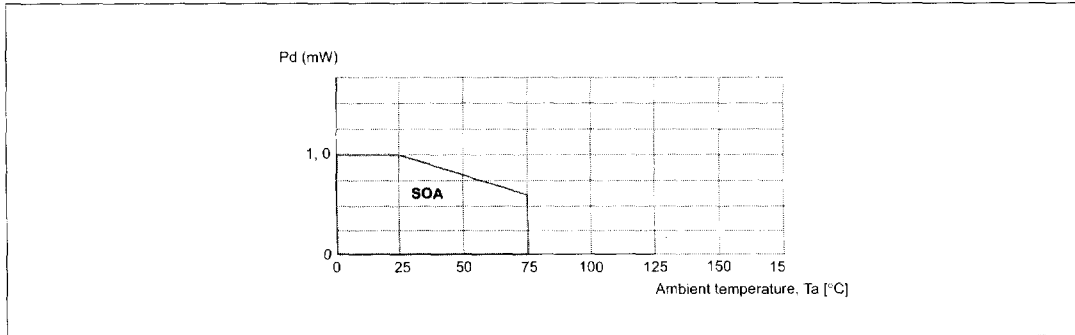

Recommended Operating Conditions (Ta = 25°C)

Parameter	Symbol	Operating voltage range	Unit
Operating supply voltage ^{note}	SVCC, PVCC	7 ~ 18	V

NOTE:

Caution 1) $PVCC \leq SVCC$

Caution 2) When PVCC is above 16V, the VCTL must be opened or $8.5 \leq VCTL \leq PVCC$

Electrical Characteristics (Ta = 25°C)

Parameter	Symbol	Conditions	Min.	Typ.	Max.	Units
Quiescent current	ICC	Pin4 & 6: GND, RL=∞	4	6.5	9.5	mA
Min. input-on current 1	IIN1	RL=∞, Pin4=IIN1, Pin5=L	-	10	30	μA
Min. input-on current 2	IIN2	RL=∞, Pin4=L, Pin5=IIN	-	10	30	μA
Input threshold voltage 1	VITH1	RL=∞, Pin4=VIN, Pin5=L	1.0	1.3	1.6	V
Input threshold voltage 2	VITH2	RL=∞, Pin4=L, Pin5=VIN	1.0	1.3	1.6	V
Output leakage current 1	IOL1	RL=∞, Pin4 & 6=GND	-	0.01	1	mA
Output leakage current 2	IOL2	RL=∞, Pin4 & 6=GND	-	0.01	1	mA
Zener current 1	Iz1	RL=∞, Pin4=H, Pin5=L	-	0.85	1.5	mA
Zener current 2	Iz2	RL=∞, Pin4=L, Pin5=H	-	0.85	1.5	mA
Output voltage 1	VO1	RL=60Ω, Pin4=H, Pin5=L	6.6	7.2	7.4	V
Output voltage 2	VO2	RL=60Ω, Pin4=L, Pin5=H	6.6	7.2	7.4	V
Saturation voltage 1 (Upper)	V SAT1	IO=300mA	-	1.9	2.3	V
Saturation voltage 2 (Upper)	VSAT2	IO=500mA	-	1.9	2.3	V
Saturation voltage 1 (Lower)	VSAT3	IO=300mA	-	0.25	0.5	V
Saturation voltage 2 (Lower)	VSAT4	IO=500mA	-	0.4	0.65	V

Application Information

1. THERMAL SHUT DOWN CIRCUIT

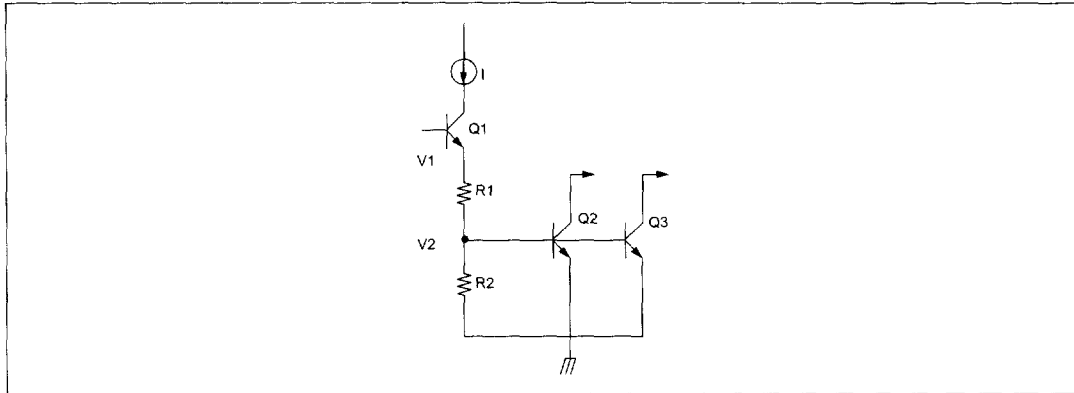

When $T_a = 25^\circ\text{C}$, Q2 & Q3 are Turned-off and output stage operates normally.

$$V_1 = I \times (R_1 + R_2)$$

$$V_2 = R_2 / (R_1 + R_2) \times V_1 = 0.37\text{V}$$

When $T_a = 165^\circ\text{C}$, Q2 & Q3 Turn-on and it turns-off the output stage.

$$0.70\text{V} - 0.37\text{V} = 330\text{mV} \text{ (When Q2 \& Q3 are Turn-on, } V_{beQ2} = V_{beQ3} = 0.70\text{V)}$$

And temperature coefficient of $Q_2 = Q_3 = -2\text{mV} / ^\circ\text{C}$

$$\therefore \text{T.S.D: } 330\text{mV} / 2\text{mV} = 165^\circ\text{C}$$

2. LOGIC INPUT & OUTPUT TABLE

Input		Output		Motor
Pin #4	Pin #5	Pin #2	Pin #8	
Low	Low	*Low	*Low	Brake
High	Low	High	Low	Forward
Low	High	Low	High	Reverse
High	High	*Low	*Low	Brake

INPUT High is above 2.0V.

INPUT Low is below 0.7V.

*Low : All Power TRs are off-state.

But internal Bias makes output Voltage low state.

3. LOGIC SWITCH CIRCUIT

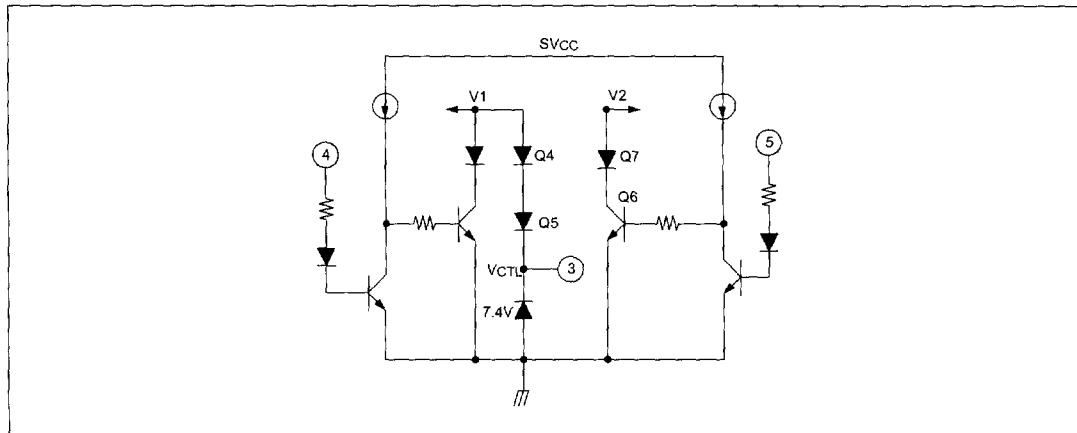

This circuit define reference voltage of output.

When pin #4 is "H" and pin #5 is "L",

- $V1 = Vz + V_{beQ4} + V_{beQ5} \approx 8.9V$
- $V2 = V_{beQ7} + V_{satQ6} \approx 0.87V$

V1 and V2 are related with the output voltage of the motor and change according to the voltage of pin #3 (VCTL).

4. DRIVE OUTPUT CIRCUIT

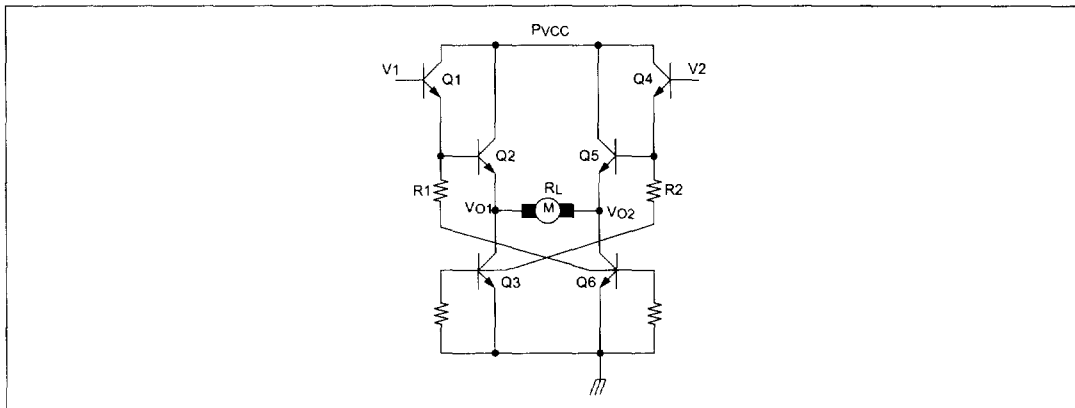

$$V_1 = 8.9V$$

$$V_2 = 0.87V$$

$$V_{O1} = V_1 - V_{BEQ1} - V_{BEQ2}$$

$$V_{O2} = V_{Q6SAT}$$

$$V_O = V_{O1} - V_{O2} = V_1 - V_{BEQ1} - V_{BEQ2} - V_{Q6SAT}$$

$$I_{RL} = (V_{O1} - V_{O2}) / R_L$$

Typical Performance Characteristics

CHARACTERISTICS GRAPHS

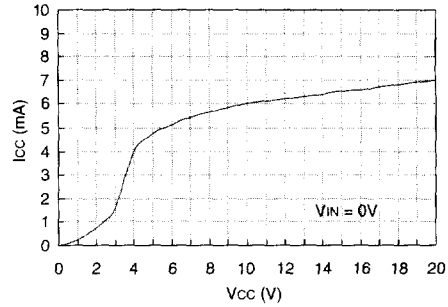
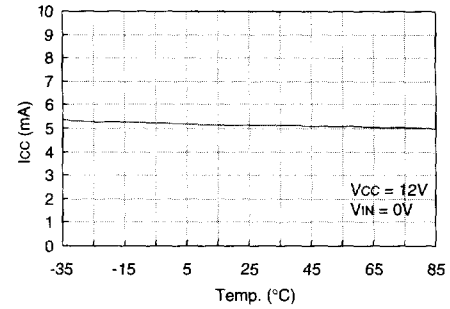
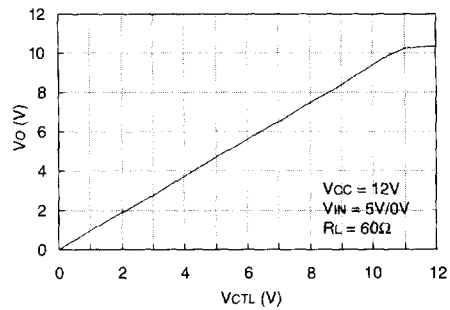
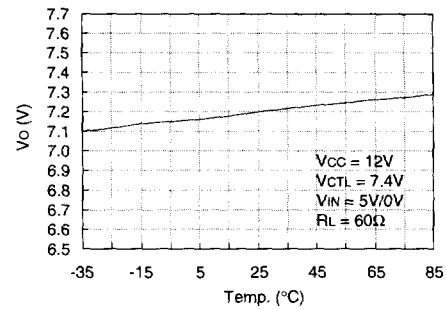
1. V_{CC} vs I_{CC} 2. Temperature vs I_{CC} 3. V_{CTL} vs. V_O 4. Temperature vs. V_O 

2

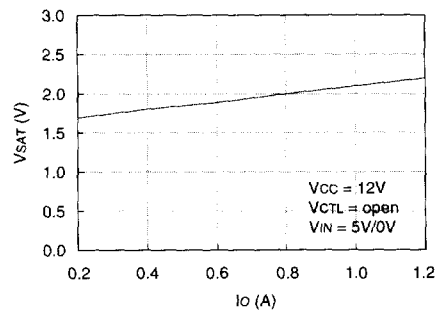
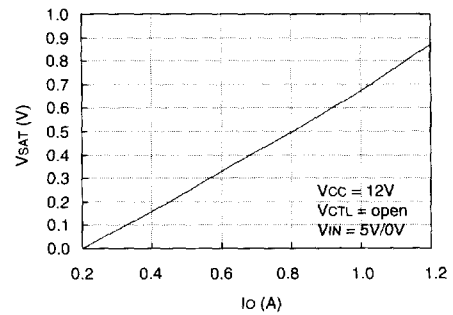
5. I_O vs. V_{SAT} (UPPER)6. I_O vs. V_{SAT} (LOWER)

Test Circuits

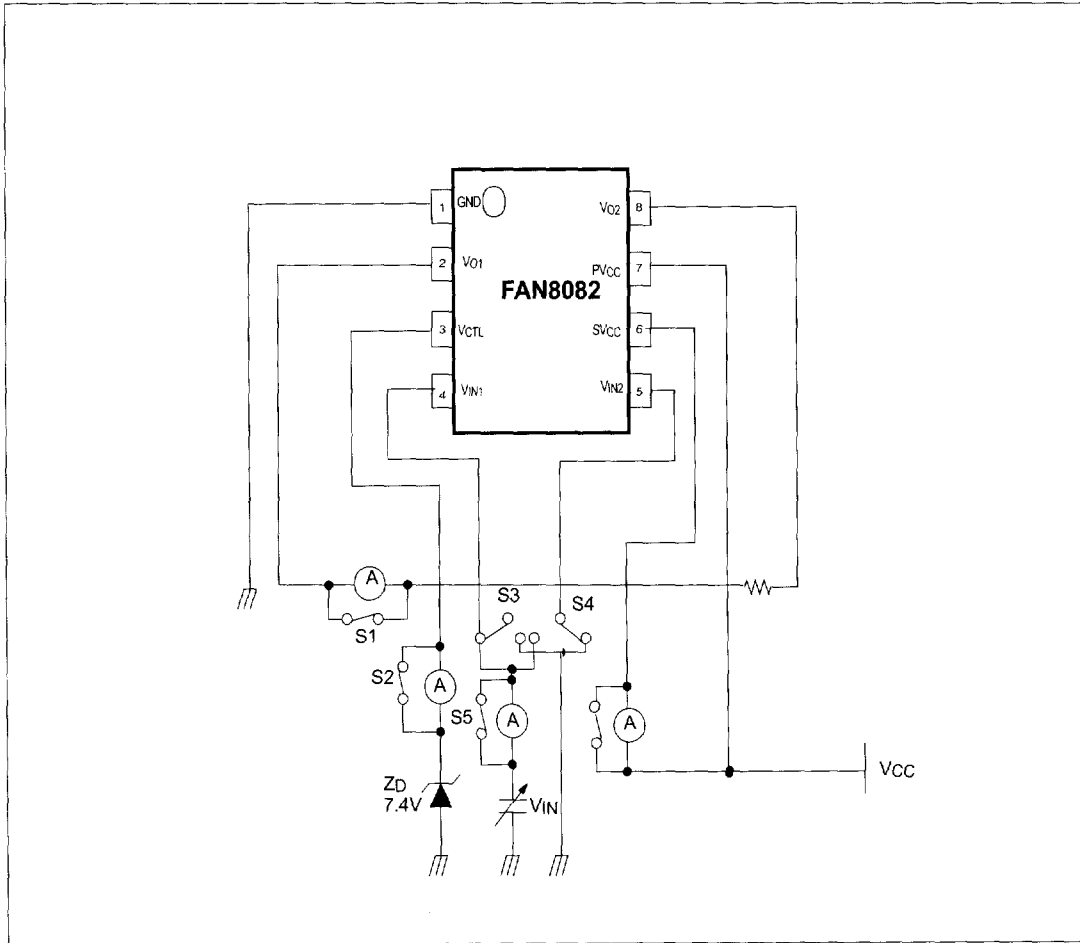

Application Circuits

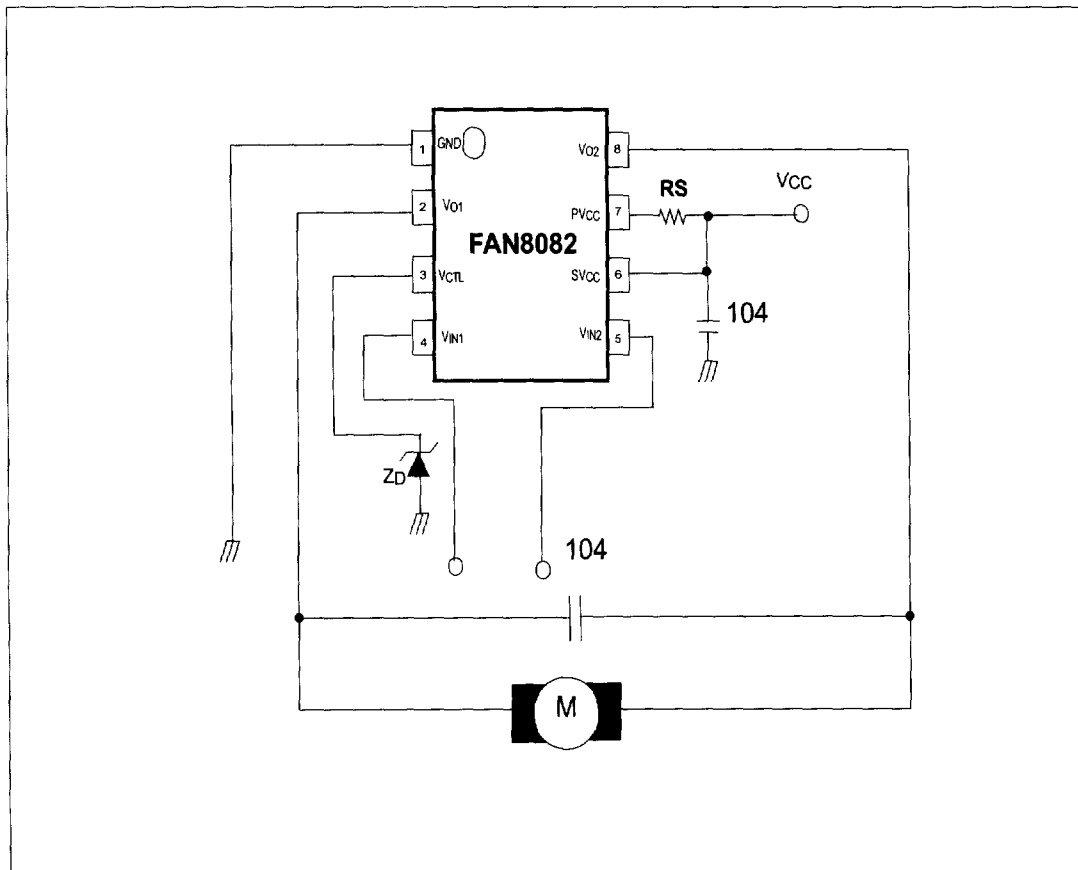

2