

DC Brushless Fan Motor Drivers

Multifunction Single-phase Full-wave Fan Motor Driver

BD61247NUX

General Description

BD61247NUX is a 1chip driver that is composed of H-bridge power DMOS FET. It realizes the quietness of the motor by PWM soft switching.

Key Specifications

- Supply Voltage Range: 4.5 V to 16 V
- Operating Temperature Range: -40 °C to +105 °C
- Output Voltage (High Side and Low Side Voltage Total): 0.2 V(Typ) at ±0.2 A

Features

- Driver Including Power DMOS FET
- Speed Controllable by PWM Input
- PWM Soft Switching
- Quick Start
- Start Assist
- Lock Protection and Automatic Restart
- High Speed Detection Protection
- Rotation Speed Pulse Signal Output (1/2FG)

Applications

- Fan Motors for General Consumer Equipment of Refrigerator etc.

Package

VSON010X3030

W(Typ) x D(Typ) x H(Max)

3.00 mm x 3.00 mm x 0.60 mm



Typical Application Circuit

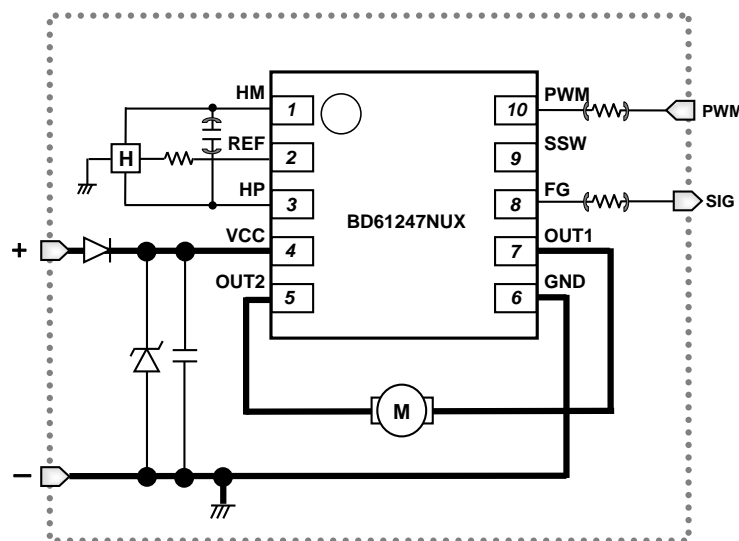

Pin Configuration

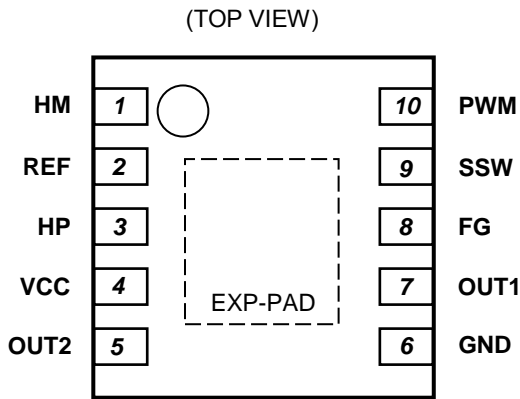

Block Diagram

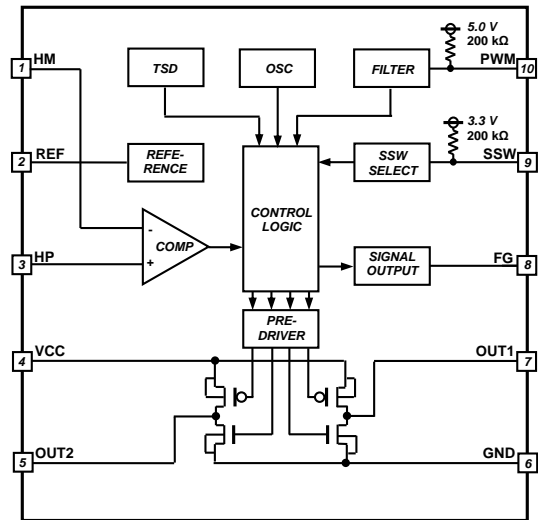

Pin Description

Pin No.	Pin Name	Function
1	HM	Hall input - pin
2	REF	Reference voltage output pin
3	HP	Hall input + pin
4	VCC	Power supply pin
5	OUT2	Motor output 2 pin
6	GND	Ground pin
7	OUT1	Motor output 1 pin
8	FG	Rotation speed pulse signal output pin
9	SSW	Soft switching setting select pin
10	PWM	PWM duty input pin
Reverse	EXP-PAD	Exposed pad (Only GND can be connected.)

Absolute Maximum Ratings

Parameter	Symbol	Rating	Unit
Supply Voltage	V _{CC}	18	V
Storage Temperature Range	T _{stg}	-55 to +150	°C
Output Voltage	V _O	18	V
Output Current	I _O	1.2	A
Rotation Speed Pulse Signal (FG) Output Voltage	V _{FG}	18	V
Rotation Speed Pulse Signal (FG) Output Current	I _{FG}	10	mA
Reference Voltage (REF) Output Current	I _{REF}	10	mA
Input Voltage1 (PWM)	V _{IN1}	6.5	V
Input Voltage2 (HP, HM, SSW)	V _{IN2}	3.6	V
Junction Temperature	T _j	150	°C

Caution 1: Operating the IC over the absolute maximum ratings may damage the IC. The damage can either be a short circuit between pins or an open circuit between pins and the internal circuitry. Therefore, it is important to consider circuit protection measures, such as adding a fuse, in case the IC is operated over the absolute maximum ratings.

Caution 2: Should by any chance the maximum junction temperature rating be exceeded the rise in temperature of the chip may result in deterioration of the properties of the chip. In case of exceeding this absolute maximum rating, design a PCB boards with thermal resistance taken into consideration by increasing board size and copper area so as not to exceed the maximum junction temperature rating.

Thermal Resistance^(Note 1)

Parameter	Symbol	Thermal Resistance (Typ)		Unit
		1s ^(Note 3)	2s2p ^(Note 4)	
VSON010X3030				
Junction to Ambient	θ _{JA}	245.7	41.6	°C/W
Junction to Top Characterization Parameter ^(Note 2)	Ψ _{JT}	10	5	°C/W

(Note 1) Based on JESD51-2A(Still-Air).

(Note 2) The thermal characterization parameter to report the difference between junction temperature and the temperature at the top center of the outside surface of the component package.

(Note 3) Using a PCB board based on JESD51-3.

(Note 4) Using a PCB board based on JESD51-5, 7.

Layer Number of Measurement Board	Material	Board Size
Single	FR-4	114.3 mm x 76.2 mm x 1.57 mmt

Top	
Copper Pattern	Thickness
Footprints and Traces	70μm

Layer Number of Measurement Board	Material	Board Size	Thermal Via ^(Note 5)	
			Pitch	Diameter
4 Layers	FR-4	114.3 mm x 76.2 mm x 1.6 mmt	1.20 mm	Φ0.30 mm

Top		2 Internal Layers		Bottom	
Copper Pattern	Thickness	Copper Pattern	Thickness	Copper Pattern	Thickness
Footprints and Traces	70 μm	74.2 mm x 74.2 mm	35 μm	74.2 mm x 74.2 mm	70 μm

(Note 5) This thermal via connects with the copper pattern of all layers.

Recommended Operating Conditions

Parameter	Symbol	Min	Typ	Max	Unit
Supply Voltage	V _{CC}	4.5	12	16	V
Hall Input Voltage	V _H	0	-	2	V
PWM Input Frequency	f _{IN}	15	-	50	kHz
Operating Temperature	Topr	-40	+25	+105	°C

Electrical Characteristics (Unless otherwise specified Ta=25 °C, V_{CC}=12 V)

Parameter	Symbol	Limit			Unit	Conditions	Typical Performance Curves
		Min	Typ	Max			
Circuit Current	I _{CC}	0.8	1.6	3.0	mA		Figure 1
Output Voltage	V _O	-	0.2	0.35	V	I _O =±0.2 A, High side and Low side voltage total	Figure 2 to Figure 5
Hall Input Hysteresis Voltage	V _{HYS}	±7	±12	±17	mV		Figure 6
PWM Input High Level	V _{PWMH}	2.5	-	5.3	V		-
PWM Input Low Level	V _{PWML}	-0.3	-	+1.0	V		-
PWM Input Current	I _{PWMH}	-10	0	+10	μA	V _{PWM} =5 V	Figure 7 to Figure 8
	I _{PWML}	-50	-25	-12	μA	V _{PWM} =0 V	
PWM Drive Frequency	f _{PWM}	30	50	70	kHz		-
Reference Voltage	V _{REF}	3.0	3.3	3.6	V	I _{REF} =-1 mA	Figure 9 to Figure 10
FG Output Low Voltage	V _{FGL}	-	-	0.3	V	I _{FG} =5 mA	Figure 11 to Figure 12
FG Output Leak Current	I _{FGL}	-	-	10	μA	V _{FG} =18 V	Figure 13
Lock Protection ON Time	t _{ON}	0.3	0.5	0.7	s		Figure 14
Lock Protection OFF Time	t _{OFF}	3.0	5.0	7.0	s		Figure 15
SSW Input High Level	V _{SSWH}	2.0	-	3.6	V		-
SSW Input Low Level	V _{SSWL}	-0.3	-	+0.8	V		-
SSW Input Current	I _{SSWH}	-10	0	+10	μA	V _{SSW} =3.3 V	Figure 16 to Figure 17
	I _{SSWL}	-34	-17	-8	μA	V _{SSW} =0 V	

For parameters involving current, positive notation means inflow of current to the IC while negative notation means outflow of current from the IC.

I/O Truth Table

Hall Input		Driver Output	
HP	HM	OUT1	OUT2
H	L	L	H
L	H	H	L

H; High, L; Low

Typical Performance Curves
(Reference Data)

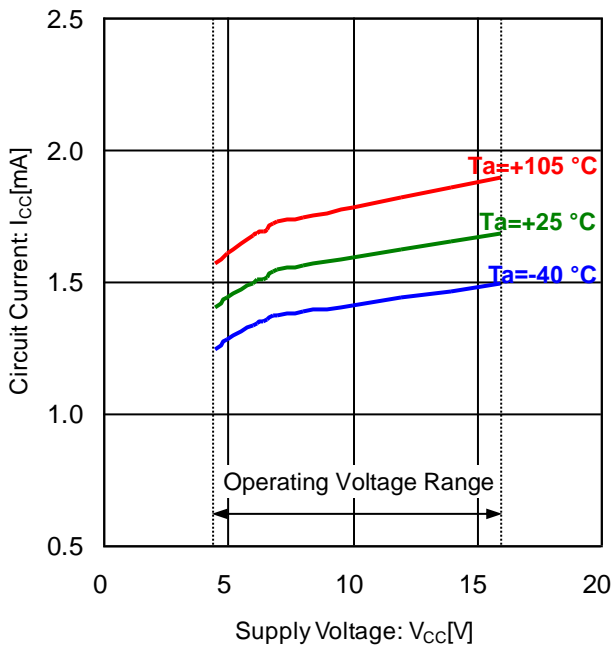

Figure 1. Circuit Current vs Supply Voltage

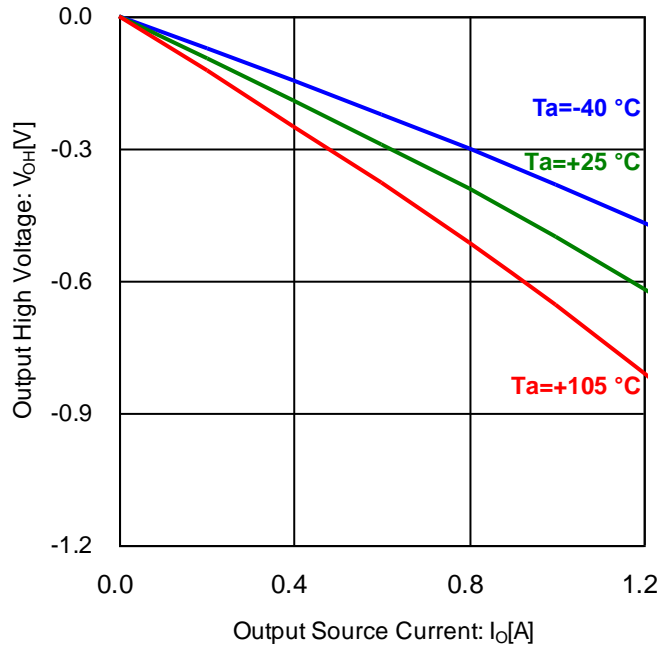

Figure 2. Output High Voltage vs Output Source Current ($V_{CC}=12\text{ V}$)

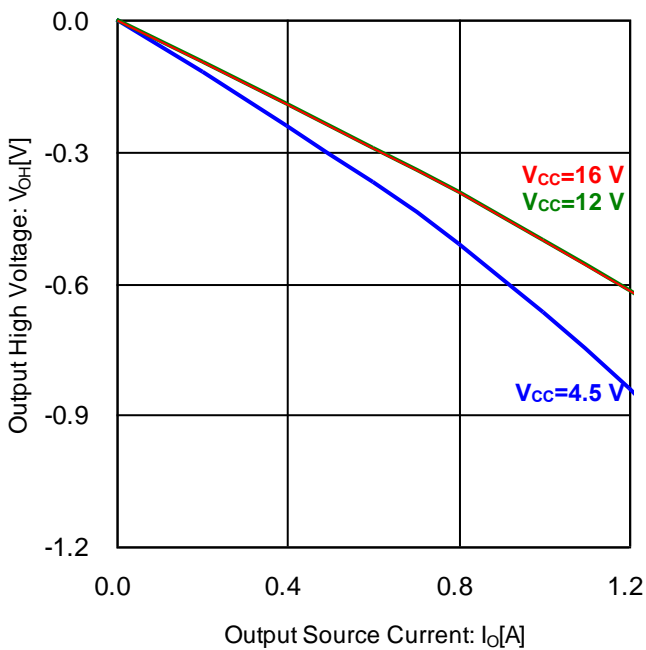

Figure 3. Output High Voltage vs Output Source Current ($T_a=25^\circ\text{C}$)

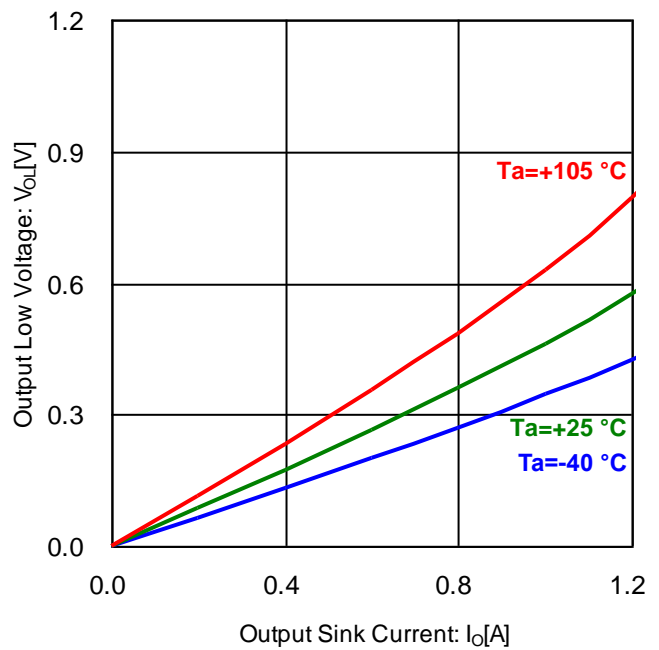

Figure 4. Output Low Voltage vs Output Sink Current ($V_{CC}=12\text{ V}$)

Typical Performance Curves – continued
(Reference Data)

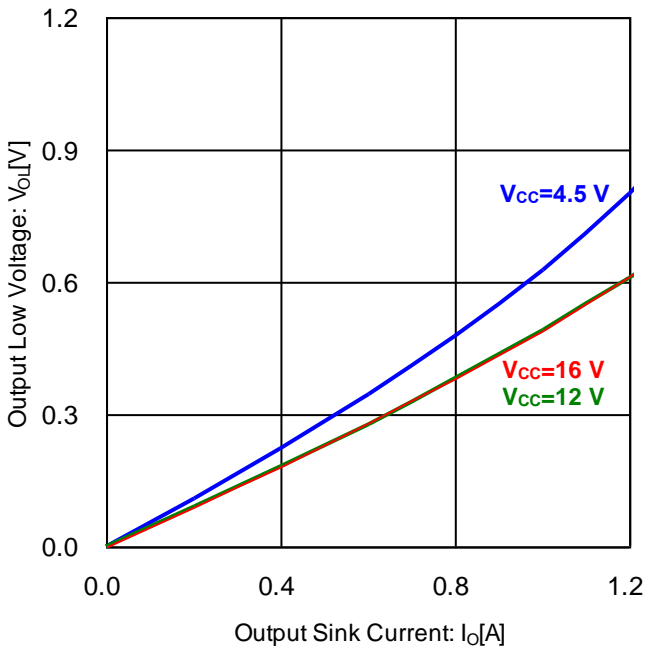

Figure 5. Output Low Voltage vs Output Sink Current (Ta=25 °C)

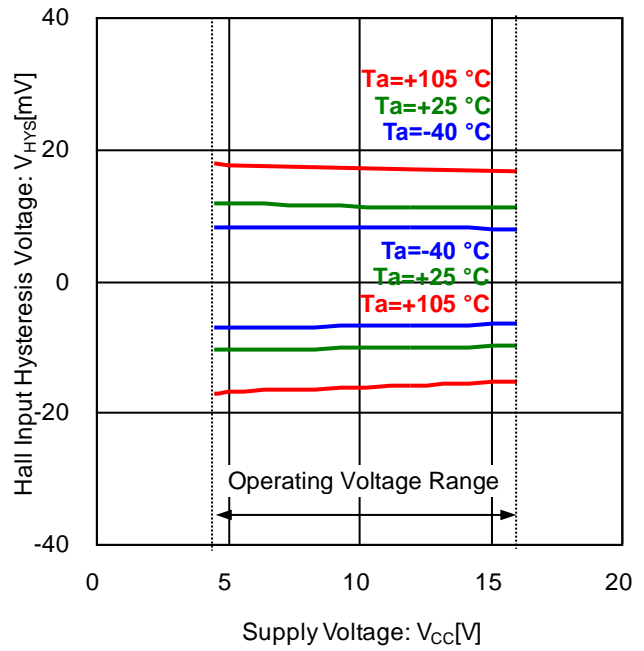

Figure 6. Hall Input Hysteresis Voltage vs Supply Voltage

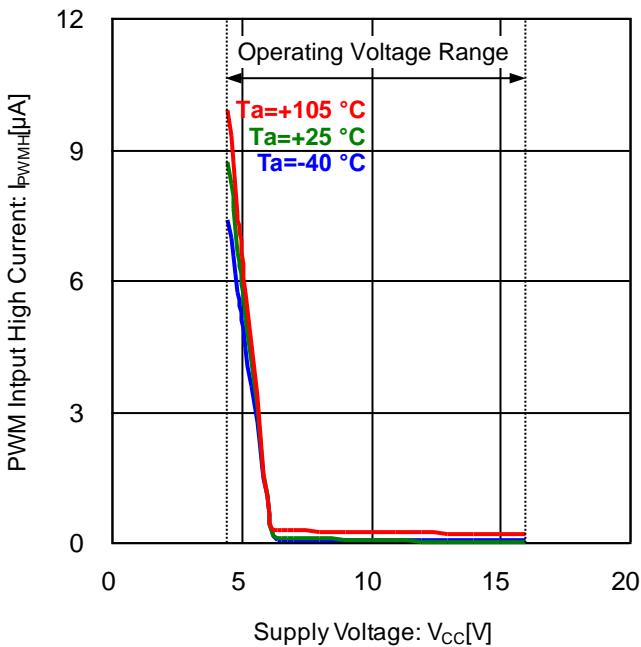

Figure 7. PWM Input High Current vs Supply Voltage (VPWM=5 V)

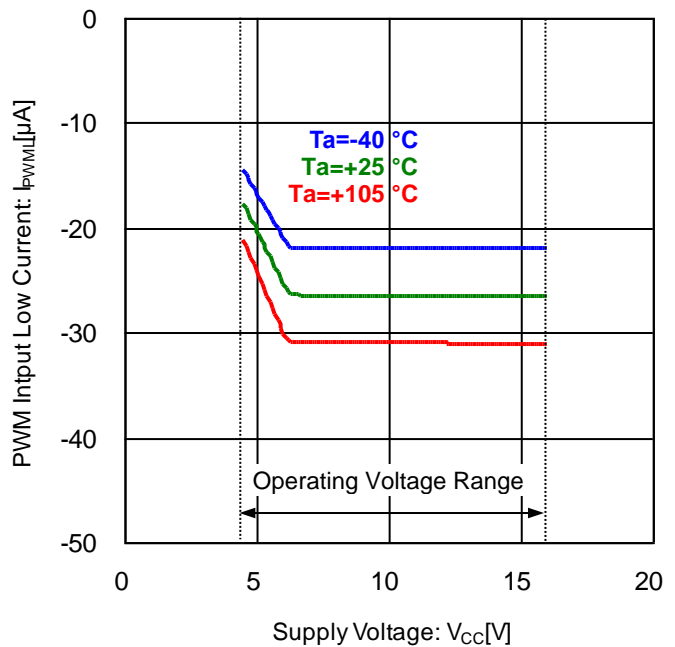

Figure 8. PWM Input Low Current vs Supply Voltage (VPWM=0 V)

Typical Performance Curves – continued
(Reference Data)

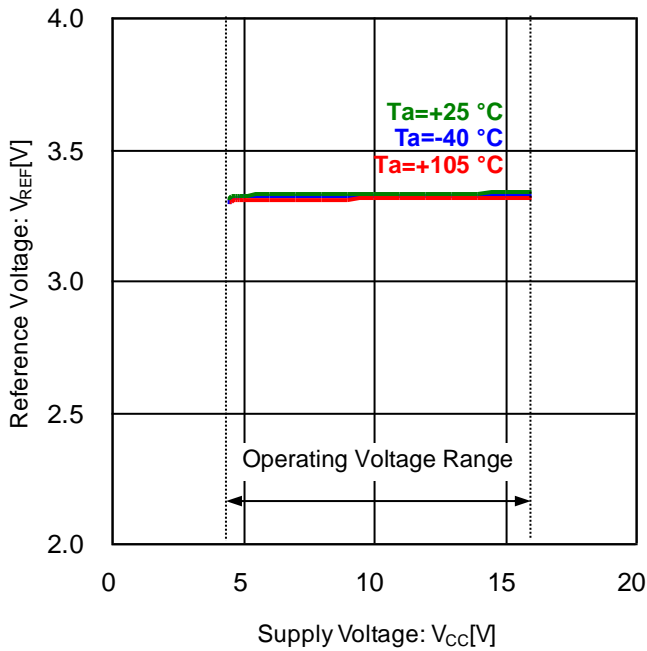

Figure 9. Reference Voltage vs Supply Voltage
($V_{CC}=12\text{ V}$)

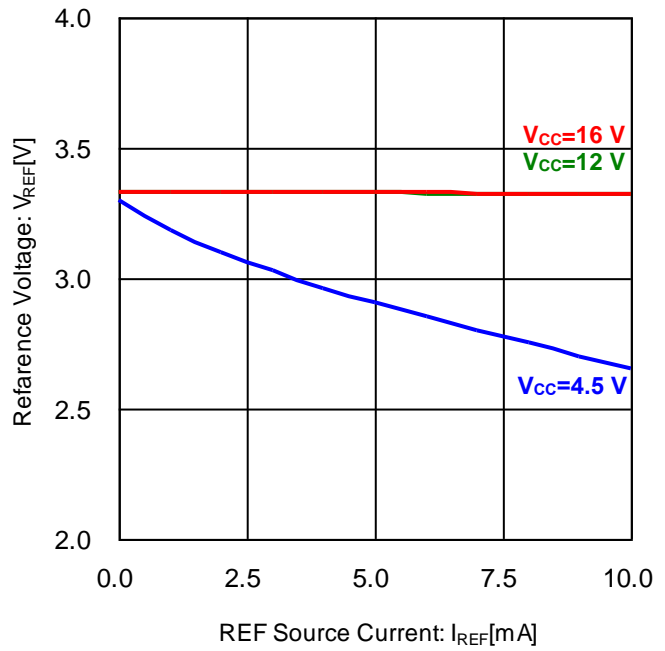

Figure 10. Reference Voltage vs REF Source Current
($T_a=25\text{ }^\circ\text{C}$)

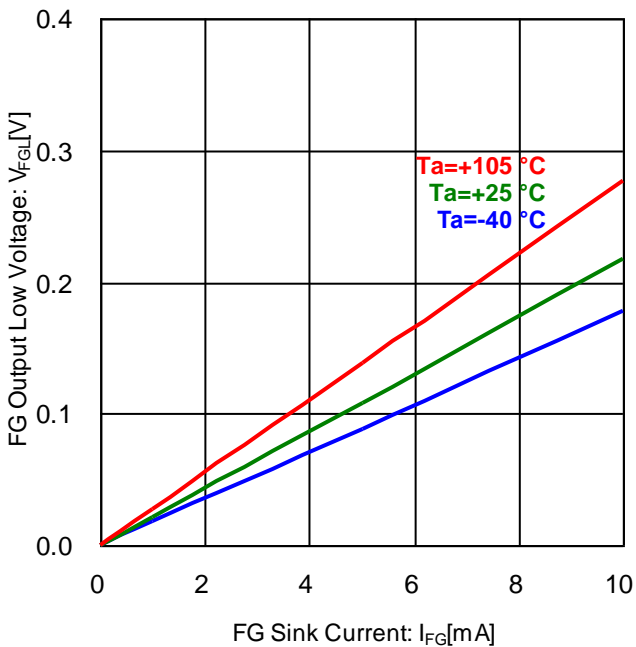

Figure 11. FG Output Low Voltage vs FG Sink Current
($V_{CC}=12\text{ V}$)

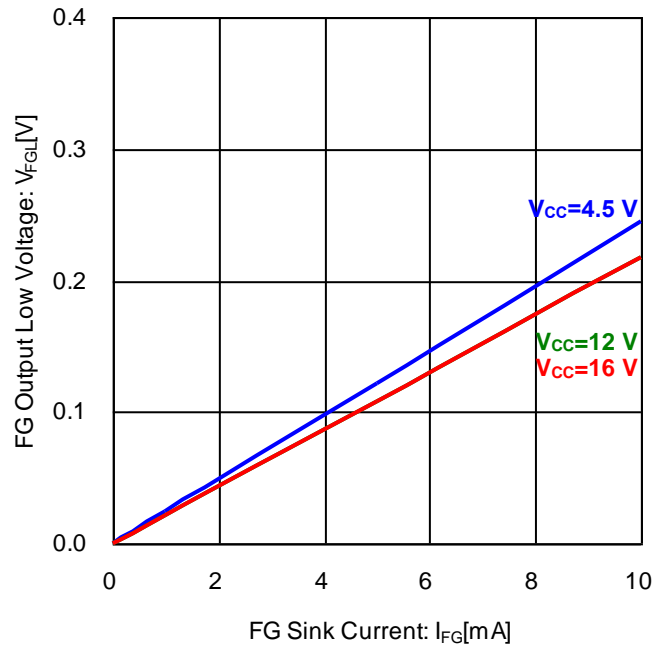

Figure 12. FG Output Low Voltage vs FG Sink Current
($T_a=25\text{ }^\circ\text{C}$)

Typical Performance Curves – continued
(Reference Data)

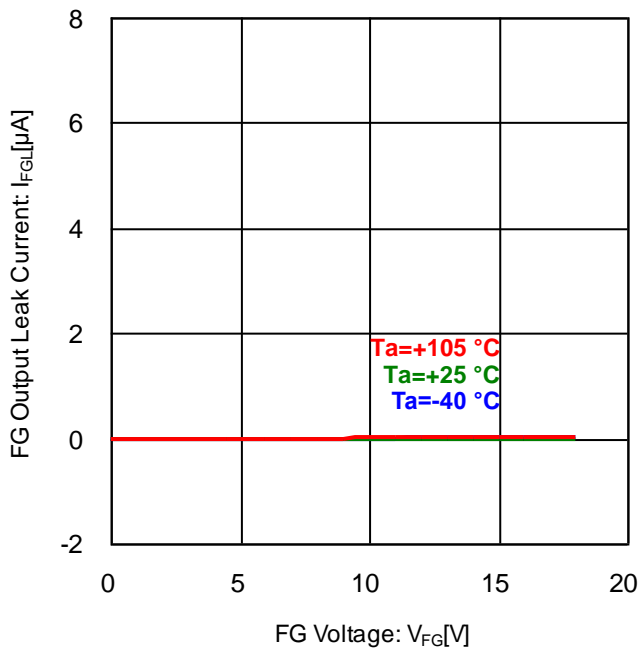

Figure 13. FG Output Leak Current vs FG Voltage
(V_{CC}=12 V)

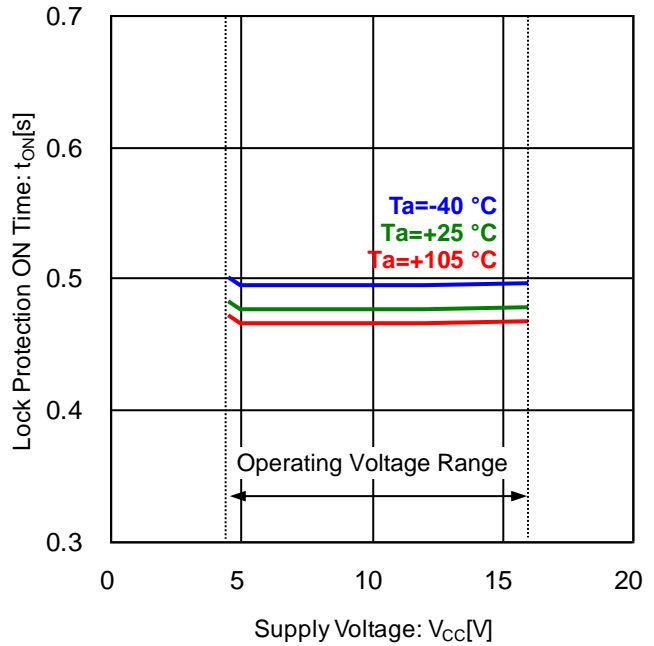

Figure 14. Lock Protection ON Time vs Supply Voltage

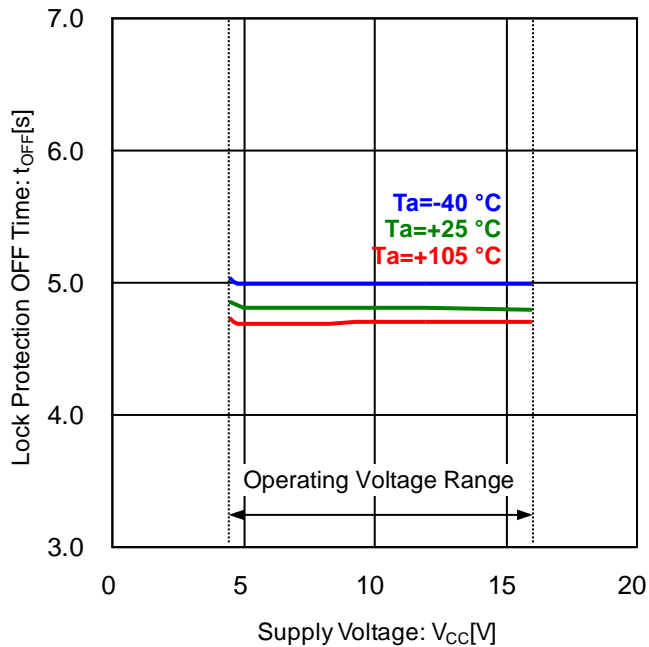

Figure 15. Lock Protection OFF Time vs Supply Voltage

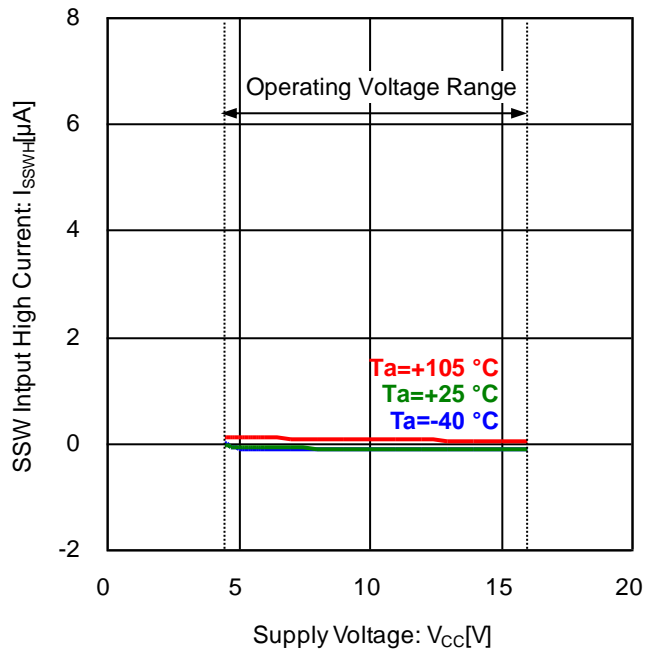

Figure 16. SSW Input High Current vs Supply Voltage
(V_{SSW}=3.3 V)

Typical Performance Curves – continued
 (Reference Data)

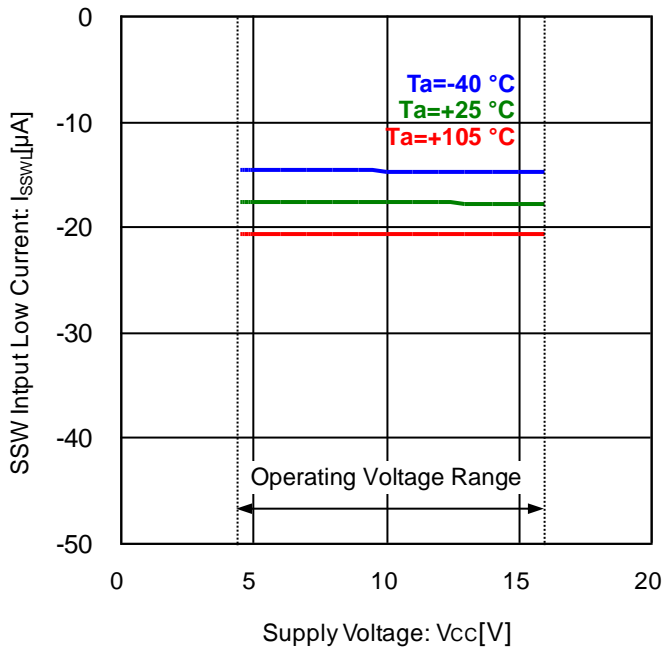

Figure 17. SSW Input Low Current vs Supply Voltage
 ($V_{SSW} = 0 V$)

Application Circuit Example (Constant Values are for Reference)

PWM Duty Input Application

This is the application example to control rotation speed by inputting a direct pulse into the PWM pin.

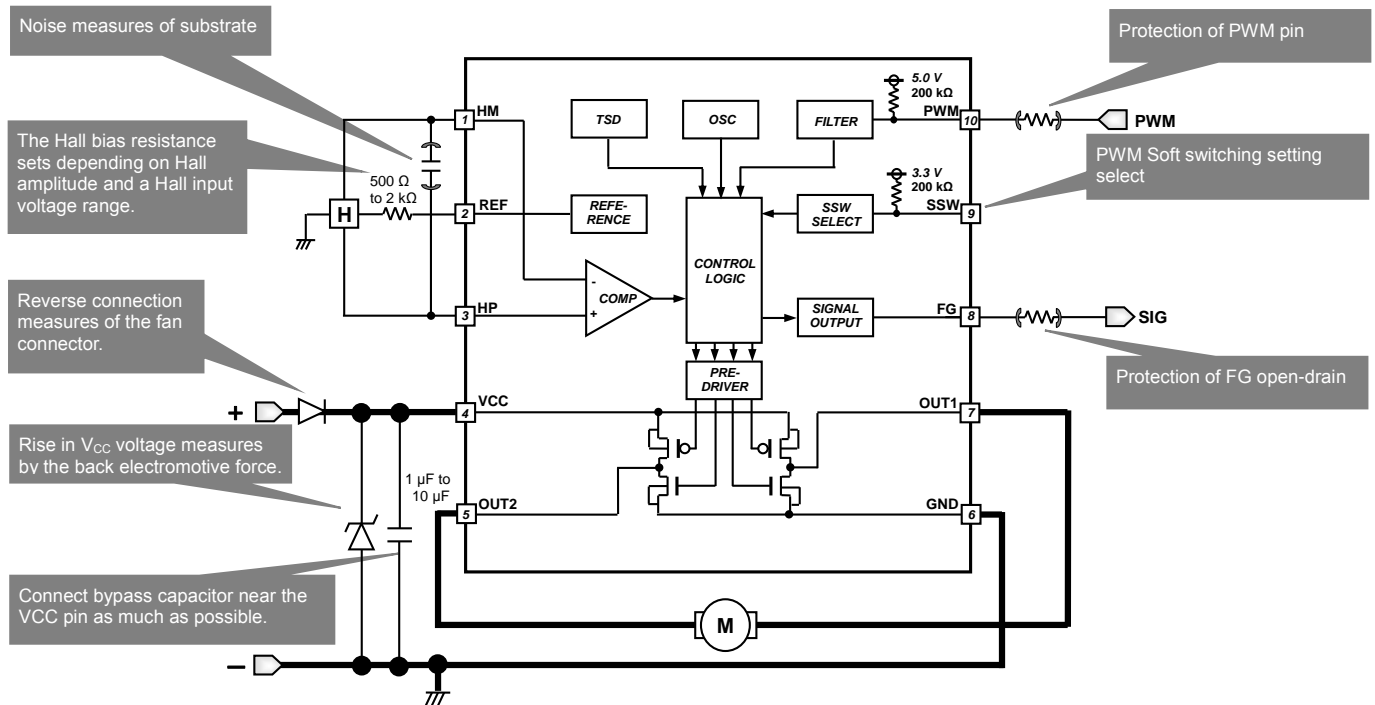

Figure 18. Application Example

The SSW pin is pulled up by resistance in the IC. This pin opening sets the High logic. A resistance pull-down or the GND pin short sets the Low logic. Please refer to [“2. Soft Switching Period and Re-circulate Period”](#) (P.11) for this function.

Application Design Note

- (1) Please connect the bypass capacitor with reference to the value mentioned above. Because there is a possibility of the motor start-up failure etc. due to the IC malfunction.

Substrate Design Note

- (1) The IC power(VCC), and motor outputs(OUT1, 2) lines are made as wide as possible.
- (2) The IC ground (GND) line is common with the application ground (e.g. Hall element ground), and arranged near to (-) land.
- (3) The bypass capacitor and the Zener diode are placed near to the VCC pin.
- (4) The HP and the HM lines are arranged side by side and made from the hall element to IC as short as possible, because it is easy for the noise to influence the hall lines.

Functional Descriptions

1. Speed Control

Output PWM duty is changed depending on input PWM duty from the PWM pin, and a motor rotational speed is also controlled. Please refer to [“Recommended Operating Conditions and Electrical Characteristics”](#) (P.4) for the signal input condition from the PWM pin. In the case of the PWM pin is open, internal supply voltage 5 V(Typ) is applied to the PWM pin, and output duty is driven in 100 %.

The resolution of input and output duty is 7 bits (127 steps).

The PWM drive frequency of the motor output is 50 kHz(Typ). The PWM drive frequency does not synchronize with input PWM frequency.

In case input PWM duty is less than 5 %, the motor output is turned OFF.

Insert the protective resistance if necessary.

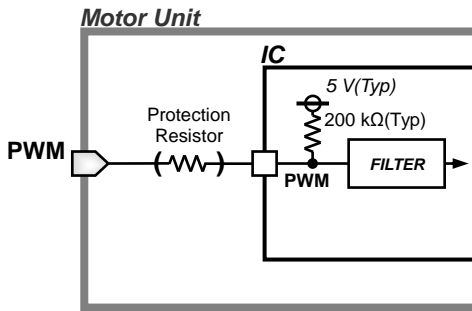

Figure 19. PWM Signal Input Application

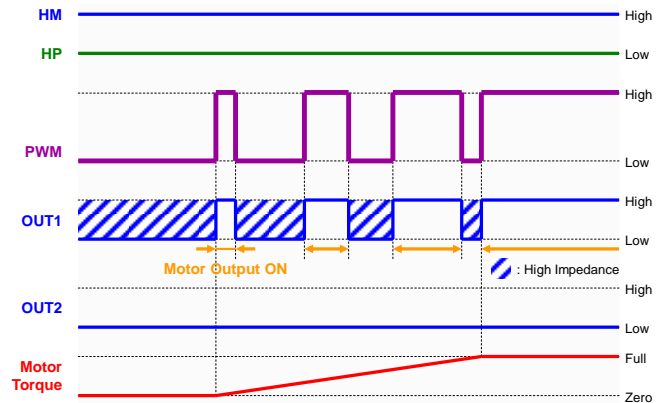

Figure 20. PWM Input Operation Timing Chart

2. Soft Switching Period and Re-circulate Period

The soft switching period and the re-circulate period can be chosen with the SSW pin.

These are defined at an angle of one period of hall signal 360° and are selected like a table depending on the SSW setting logic.

SSW pin	SSW Setting Logic	Soft Switching Angle	Re-Circulate Angle
OPEN	H	78.75°	5.63°
GND short	L	67.50°	8.44°

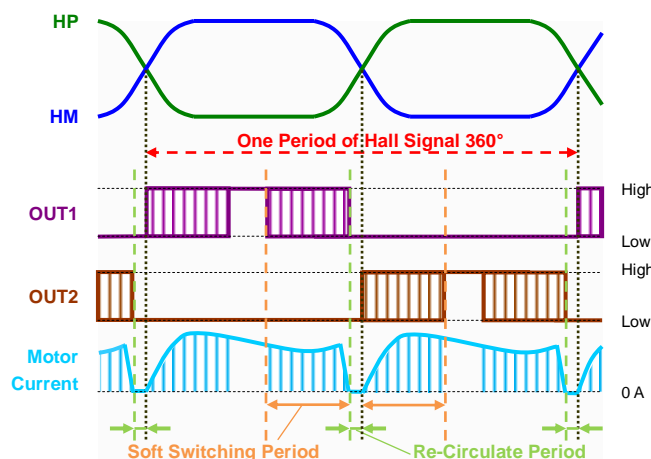

Figure 21. Setting of a Soft Switching Period and Re-Circulate Period

The soft switching period means the section where output PWM duty changes from 0% just after the phase change to setting duty or a section changing from setting duty to 0%. To smooth off the current waveform, the coefficient table that duty gradually changes with 16 steps is set the inside IC.

The re-circulate period means the section where the coil current re-circulate before the timing of output phase change. It is effective to suppress leaping up of voltage by back electromotive force, and reduce invalid electricity consumption.

Functional Descriptions – continued

3. Quick Start

After having stopped a motor in the PWM signal to input from the outside, a lock protection is turned off when input of the PWM Low logic continues a given period of time or more. The motor can be restarted without being influenced at lock protection time.

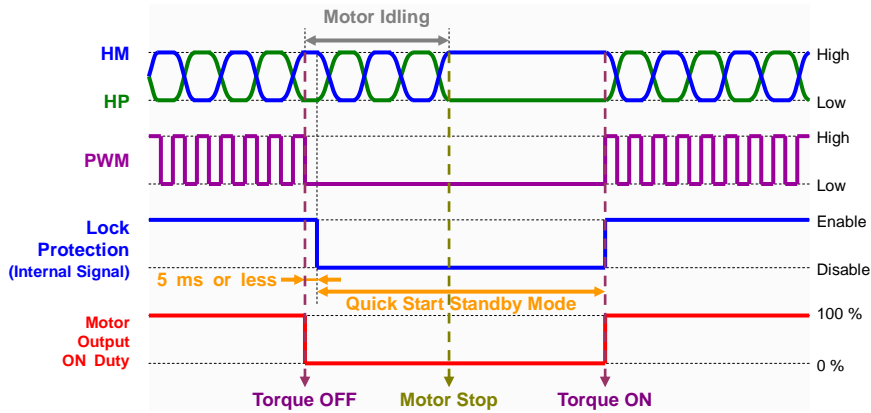

Figure 22. Quick Start Timing Chart

4. Start Assist Function

It is function that enables the motor to start even if input PWM duty is low. When input PWM duty is less than 50 % in a condition at the time of the following motor starting, output PWM duty is set in 50 % till three times of hall signal change are detected.

Motor starting condition

- a) Power ON
- b) Quick Start
- c) Lock Protection Release

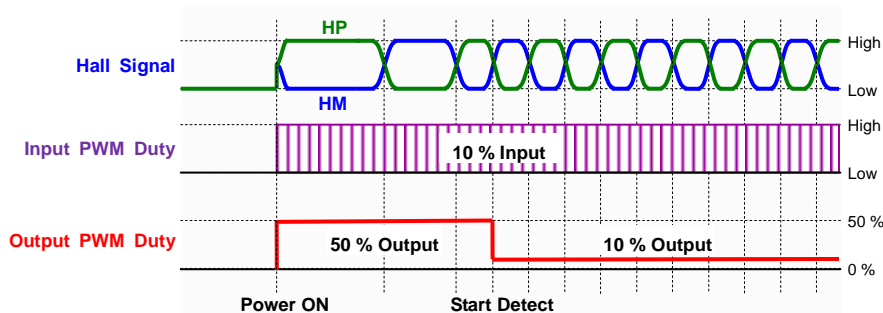

Figure 23. Start Assist Operation at Input Duty 10 %

5. Lock Protection and Automatic Restart

The motor rotation is detected by the hall signal period. The IC detects motor rotation is locked when the period becomes longer than the time set up at the internal counter, and the IC turns off outputs. The lock protection ON time (t_{ON}) and the lock protection OFF time (t_{OFF}) are set by the digital counter based on internal oscillator. Therefore, the ratio of ON/OFF time is always constant.

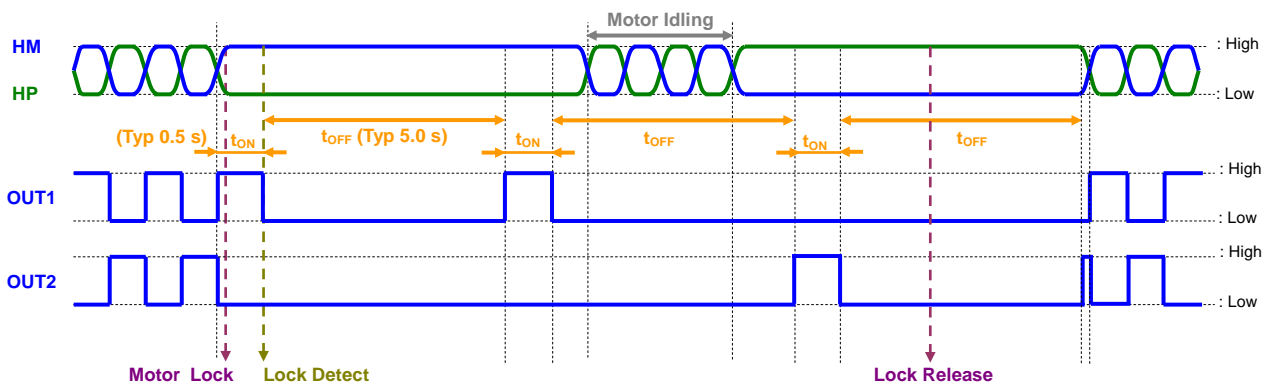

Figure 24. Lock Protection Timing Chart

Functional Descriptions – continued

6. Hall Input Setting

Please input the hall signal level within the recommended operating condition “Hall Input Voltage” (P.4) including amplitude of the signal. The hall amplitude of the “Hall Input Hysteresis Voltage” or more is necessary to detect rotation of a motor.

The amplitude of the hall signal recommends 100 mVpp or more, but please input 34 mVpp or more at least.

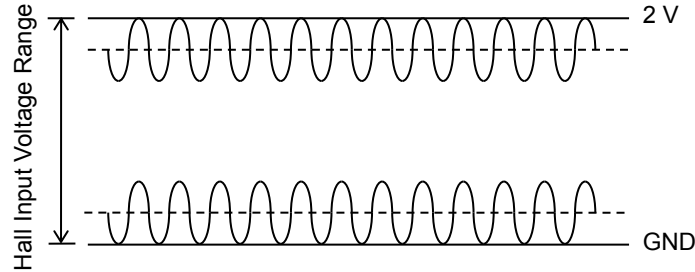

Figure 25. Hall Input Voltage Range

○Reducing the Noise of Hall Signal

The hall element may be affected by V_{CC} noise depending on the wiring pattern of board. In this case, place a capacitor like C1 in Figure 26. In addition, when wiring from the hall element output to the IC hall input is long, noise may be loaded on wiring. In this case, place a capacitor like C2 in Figure 26.

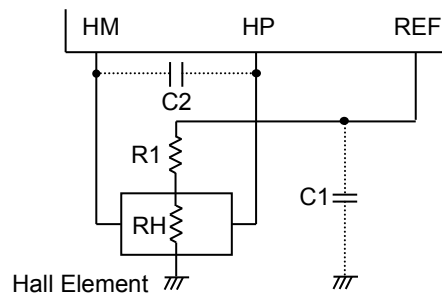

Figure 26. Application Near of Hall Signal

7. High Speed Detection Protection

The high speed detection protection begins the lock protection action when it detects that the hall input signal is in an abnormal state (2.5 kHz(Typ) or more).

8. Rotation Speed Pulse Signal Output (1/2FG)

A pulse signal depending on the rotation speed of the motor is output from the FG pin. Hall edge signal in the IC is generated from changing hall signal. The FG signal changes with two pulses of the hall edge signal shown as Figure 27. FG signal may shift for one hall edge depending on the initial hall signal input logic at the time of the motor start.

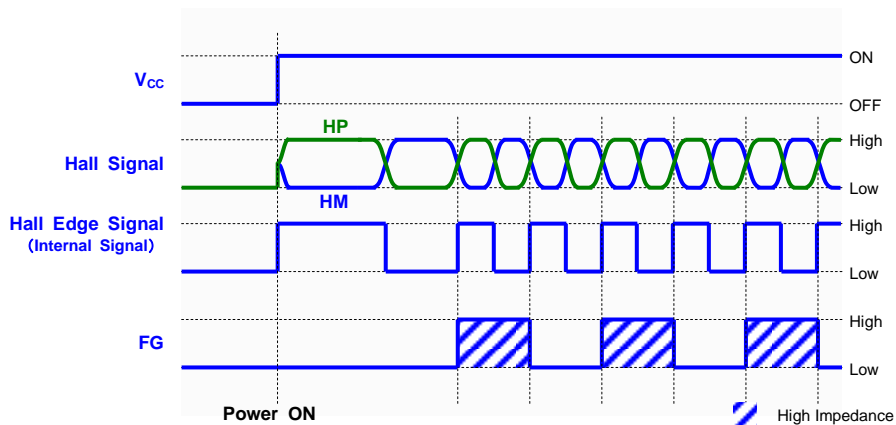
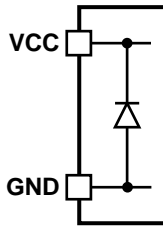

Figure 27. Rotation Speed Pulse Output Timing Chart of Power ON

I/O Equivalence Circuit (Resistance Values are Typical)

1. Power supply pin



2. PWM duty input pin

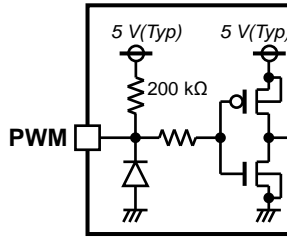

3. Hall input pin

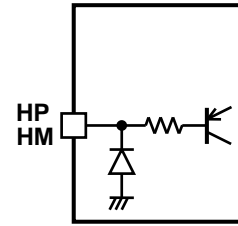

4. Soft switching setting select pin

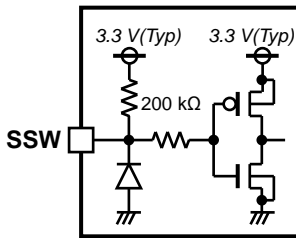

5. Reference voltage output pin

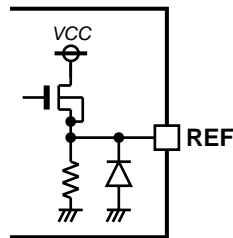

6. Motor output pin

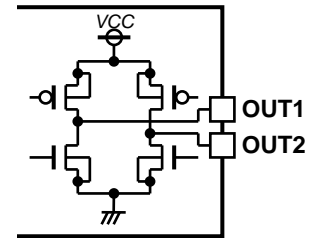

7. Rotation speed pulse signal output pin

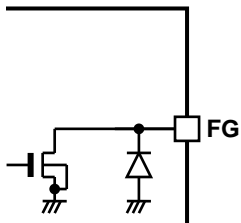

Safety Measures

1. Reverse Connection Protection Diode

The reverse connection of the power results in the IC destruction as shown in Figure 28. When the reverse connection is possible, the reverse connection protection diode must be added between the power supply and the VCC pin.

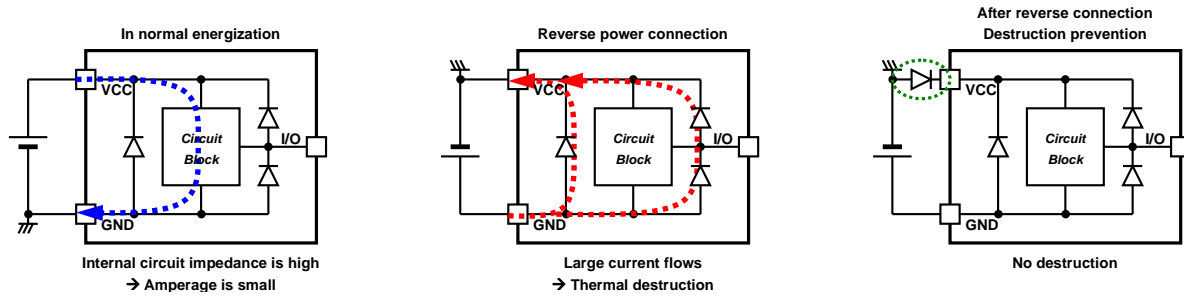

Figure 28. Flow of Current When the Power is Connected Reversely

2. Protection against VCC Voltage Rise by Back Electromotive Force

The back electromotive force (Back EMF) generates regenerative current to the power supply. However, when the reverse connection protection diode is connected to the power supply line as shown in Figure 29, the VCC voltage rises because the diode prevents current flow to the power supply.

When the absolute maximum rated voltage may be exceeded due to the voltage rise by the back electromotive force, place a (A) capacitor or (B) Zener diode between the VCC pin and the GND pin for regenerative current path as shown in Figure 30. If further measures are necessary, use measures of (A) and (B) together like as (C). The capacitor and the resistor can be used to have better voltage surge protection like as (D).

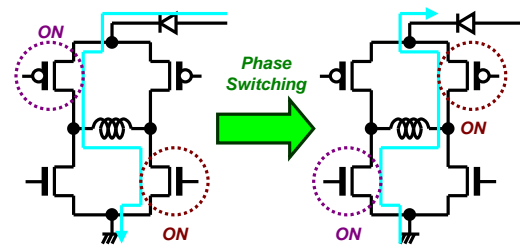

Figure 29. VCC Voltage Rise by Back Electromotive

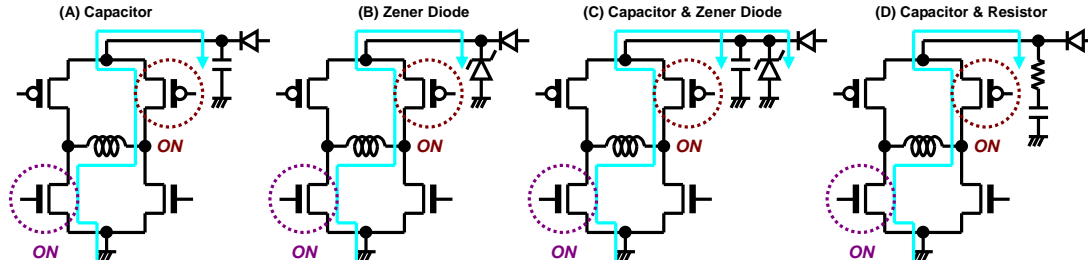

Figure 30. Measure Against VCC and Motor Driving Outputs Voltage

3. PWM Switching of GND Line

Do not perform the PWM switching of the GND line because the GND pin potential cannot be kept to a minimum.

4. Protection of Input Pin and Output Pin

Misconnecting of the external connector from the motor PCB or plugging and unplugging the hot connector may cause damage to the IC by the rush current or the over voltage surge.

About the input pin and the output pin except the VCC pin and the GND pin, please take measures such as using the protection resistor so that the IC is not affected by the over voltage or the over current as shown in Figure 32.

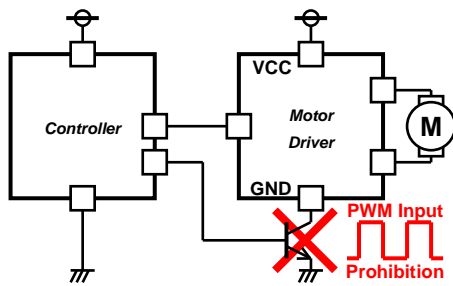

Figure 31. Prohibition of the GND Line PWM Switching

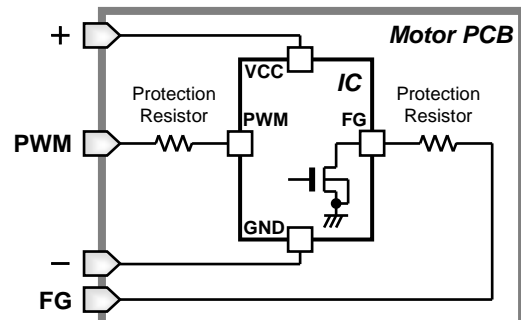

Figure 32. Protection of the PWM Pin and the FG Pin

Operational Notes

1. Reverse Connection of Power Supply

Connecting the power supply in reverse polarity can damage the IC. Take precautions against reverse polarity when connecting the power supply, such as mounting an external diode between the power supply and the IC's power supply pins.

2. Power Supply Lines

Design the PCB layout pattern to provide low impedance supply lines. Furthermore, connect a capacitor to ground at all power supply pins. Consider the effect of temperature and aging on the capacitance value when using electrolytic capacitors.

3. Ground Voltage

Ensure that no pins are at a voltage below that of the ground pin at any time, even during transient condition. However, pins that drive inductive loads (e.g. motor driver outputs, DC-DC converter outputs) may inevitably go below ground due to back EMF or electromotive force. In such cases, the user should make sure that such voltages going below ground will not cause the IC and the system to malfunction by examining carefully all relevant factors and conditions such as motor characteristics, supply voltage, operating frequency and PCB wiring to name a few.

4. Ground Wiring Pattern

When using both small-signal and large-current ground traces, the two ground traces should be routed separately but connected to a single ground at the reference point of the application board to avoid fluctuations in the small-signal ground caused by large currents. Also ensure that the ground traces of external components do not cause variations on the ground voltage. The ground lines must be as short and thick as possible to reduce line impedance.

5. Recommended Operating Conditions

The function and operation of the IC are guaranteed within the range specified by the recommended operating conditions. The characteristic values are guaranteed only under the conditions of each item specified by the electrical characteristics.

6. Inrush Current

When power is first supplied to the IC, it is possible that the internal logic may be unstable and inrush current may flow instantaneously due to the internal powering sequence and delays, especially if the IC has more than one power supply. Therefore, give special consideration to power coupling capacitance, power wiring, width of ground wiring, and routing of connections.

7. Operation Under Strong Electromagnetic Field

Operating the IC in the presence of a strong electromagnetic field may cause the IC to malfunction.

8. Testing on Application Boards

When testing the IC on an application board, connecting a capacitor directly to a low-impedance output pin may subject the IC to stress. Always discharge capacitors completely after each process or step. The IC's power supply should always be turned off completely before connecting or removing it from the test setup during the inspection process. To prevent damage from static discharge, ground the IC during assembly and use similar precautions during transport and storage.

9. Inter-pin Short and Mounting Errors

Ensure that the direction and position are correct when mounting the IC on the PCB. Incorrect mounting may result in damaging the IC. Avoid nearby pins being shorted to each other especially to ground, power supply and output pin. Inter-pin shorts could be due to many reasons such as metal particles, water droplets (in very humid environment) and unintentional solder bridge deposited in between pins during assembly to name a few.

10. Unused Input Pins

Input pins of an IC are often connected to the gate of a MOS transistor. The gate has extremely high impedance and extremely low capacitance. If left unconnected, the electric field from the outside can easily charge it. The small charge acquired in this way is enough to produce a significant effect on the conduction through the transistor and cause unexpected operation of the IC. So unless otherwise specified, unused input pins should be connected to the power supply or ground line.

Operational Notes – continued

11. Regarding the Input Pin of the IC

This monolithic IC contains P+ isolation and P substrate layers between adjacent elements in order to keep them isolated. P-N junctions are formed at the intersection of the P layers with the N layers of other elements, creating a parasitic diode or transistor. For example (refer to figure below):

When GND > Pin A and GND > Pin B, the P-N junction operates as a parasitic diode.

When GND > Pin B, the P-N junction operates as a parasitic transistor.

Parasitic diodes inevitably occur in the structure of the IC. The operation of parasitic diodes can result in mutual interference among circuits, operational faults, or physical damage. Therefore, conditions that cause these diodes to operate, such as applying a voltage lower than the GND voltage to an input pin (and thus to the P substrate) should be avoided.

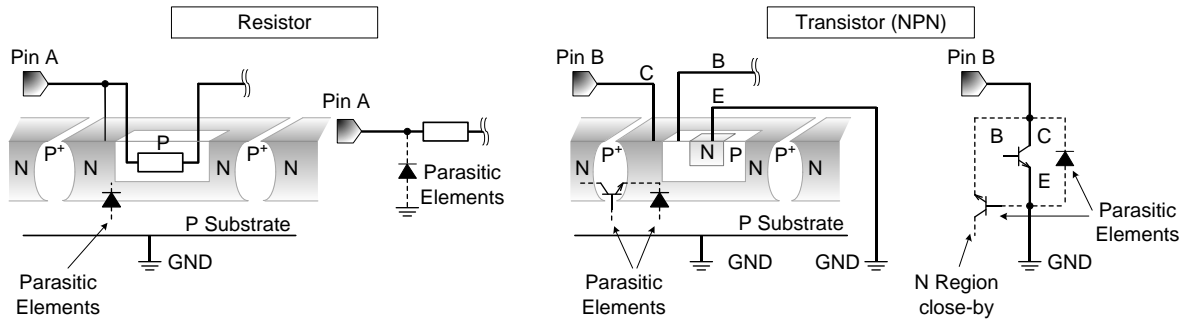

Figure 33. Example of Monolithic IC Structure

12. Ceramic Capacitor

When using a ceramic capacitor, determine a capacitance value considering the change of capacitance with temperature and the decrease in nominal capacitance due to DC bias and others.

13. Area of Safe Operation (ASO)

Operate the IC such that the output voltage, output current, and the maximum junction temperature rating are all within the Area of Safe Operation (ASO).

14. Thermal Shutdown Circuit (TSD)

This IC has a built-in thermal shutdown circuit that prevents heat damage to the IC. Normal operation should always be within the IC's maximum junction temperature rating. If however the rating is exceeded for a continued period, the junction temperature (T_j) will rise which will activate the TSD circuit that will turn OFF power output pins. When the T_j falls below the TSD threshold, the circuits are automatically restored to normal operation.

Note that the TSD circuit operates in a situation that exceeds the absolute maximum ratings and therefore, under no circumstances, should the TSD circuit be used in a set design or for any purpose other than protecting the IC from heat damage.

Ordering Information

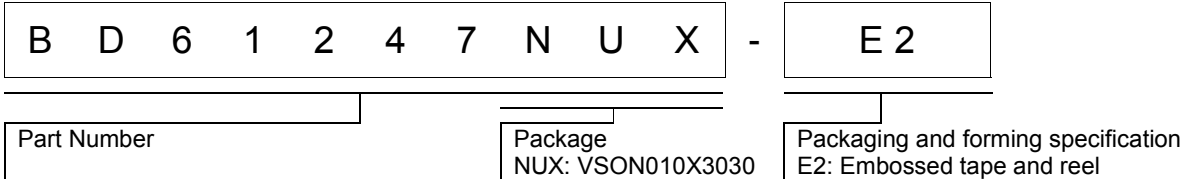

Marking Diagram

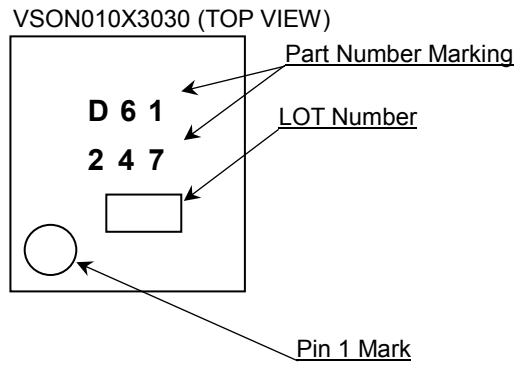

Physical Dimension and Packing Information

Package Name	VSON010X3030
--------------	--------------

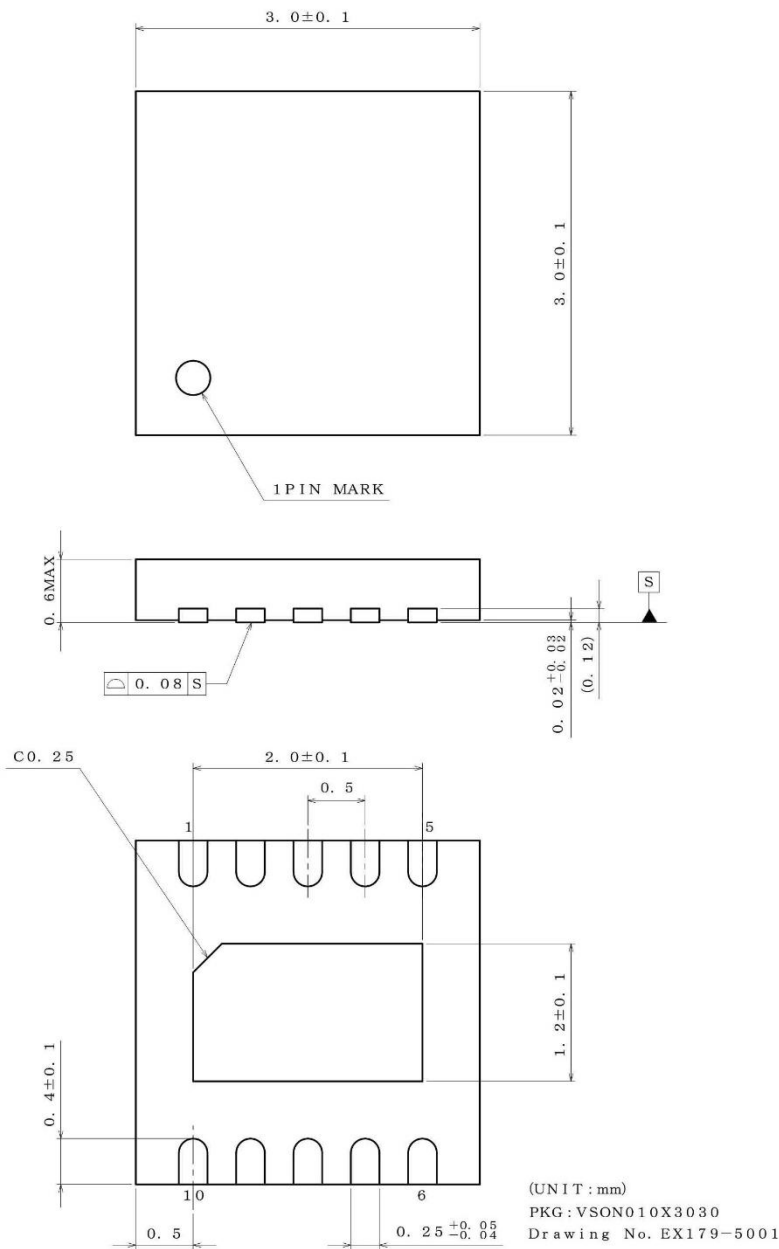

< Tape and Reel Information >

Tape	Embossed carrier tape
Quantity	4000pcs
Direction of feed	E2 The direction is the pin 1 of product is at the upper left when you hold reel on the left hand and you pull out the tape on the right hand

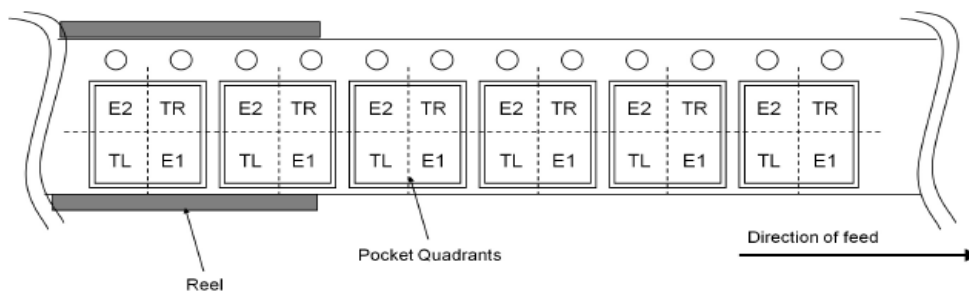

Revision History

Date	Revision	Changes
31.May.2018	001	New Release

Notice

Precaution on using ROHM Products

- Our Products are designed and manufactured for application in ordinary electronic equipment (such as AV equipment, OA equipment, telecommunication equipment, home electronic appliances, amusement equipment, etc.). If you intend to use our Products in devices requiring extremely high reliability (such as medical equipment ^(Note 1), transport equipment, traffic equipment, aircraft/spacecraft, nuclear power controllers, fuel controllers, car equipment including car accessories, safety devices, etc.) and whose malfunction or failure may cause loss of human life, bodily injury or serious damage to property ("Specific Applications"), please consult with the ROHM sales representative in advance. Unless otherwise agreed in writing by ROHM in advance, ROHM shall not be in any way responsible or liable for any damages, expenses or losses incurred by you or third parties arising from the use of any ROHM's Products for Specific Applications.

(Note1) Medical Equipment Classification of the Specific Applications

JAPAN	USA	EU	CHINA
CLASS III	CLASS III	CLASS II b	CLASS III
CLASS IV		CLASS III	

- ROHM designs and manufactures its Products subject to strict quality control system. However, semiconductor products can fail or malfunction at a certain rate. Please be sure to implement, at your own responsibilities, adequate safety measures including but not limited to fail-safe design against the physical injury, damage to any property, which a failure or malfunction of our Products may cause. The following are examples of safety measures:
 - Installation of protection circuits or other protective devices to improve system safety
 - Installation of redundant circuits to reduce the impact of single or multiple circuit failure
- Our Products are designed and manufactured for use under standard conditions and not under any special or extraordinary environments or conditions, as exemplified below. Accordingly, ROHM shall not be in any way responsible or liable for any damages, expenses or losses arising from the use of any ROHM's Products under any special or extraordinary environments or conditions. If you intend to use our Products under any special or extraordinary environments or conditions (as exemplified below), your independent verification and confirmation of product performance, reliability, etc. prior to use, must be necessary:
 - Use of our Products in any types of liquid, including water, oils, chemicals, and organic solvents
 - Use of our Products outdoors or in places where the Products are exposed to direct sunlight or dust
 - Use of our Products in places where the Products are exposed to sea wind or corrosive gases, including Cl₂, H₂S, NH₃, SO₂, and NO₂
 - Use of our Products in places where the Products are exposed to static electricity or electromagnetic waves
 - Use of our Products in proximity to heat-producing components, plastic cords, or other flammable items
 - Sealing or coating our Products with resin or other coating materials
 - Use of our Products without cleaning residue of flux (even if you use no-clean type fluxes, cleaning residue of flux is recommended); or Washing our Products by using water or water-soluble cleaning agents for cleaning residue after soldering
 - Use of the Products in places subject to dew condensation
- The Products are not subject to radiation-proof design.
- Please verify and confirm characteristics of the final or mounted products in using the Products.
- In particular, if a transient load (a large amount of load applied in a short period of time, such as pulse. is applied, confirmation of performance characteristics after on-board mounting is strongly recommended. Avoid applying power exceeding normal rated power; exceeding the power rating under steady-state loading condition may negatively affect product performance and reliability.
- De-rate Power Dissipation depending on ambient temperature. When used in sealed area, confirm that it is the use in the range that does not exceed the maximum junction temperature.
- Confirm that operation temperature is within the specified range described in the product specification.
- ROHM shall not be in any way responsible or liable for failure induced under deviant condition from what is defined in this document.

Precaution for Mounting / Circuit board design

- When a highly active halogenous (chlorine, bromine, etc.) flux is used, the residue of flux may negatively affect product performance and reliability.
- In principle, the reflow soldering method must be used on a surface-mount products, the flow soldering method must be used on a through hole mount products. If the flow soldering method is preferred on a surface-mount products, please consult with the ROHM representative in advance.

For details, please refer to ROHM Mounting specification

Precautions Regarding Application Examples and External Circuits

1. If change is made to the constant of an external circuit, please allow a sufficient margin considering variations of the characteristics of the Products and external components, including transient characteristics, as well as static characteristics.
2. You agree that application notes, reference designs, and associated data and information contained in this document are presented only as guidance for Products use. Therefore, in case you use such information, you are solely responsible for it and you must exercise your own independent verification and judgment in the use of such information contained in this document. ROHM shall not be in any way responsible or liable for any damages, expenses or losses incurred by you or third parties arising from the use of such information.

Precaution for Electrostatic

This Product is electrostatic sensitive product, which may be damaged due to electrostatic discharge. Please take proper caution in your manufacturing process and storage so that voltage exceeding the Products maximum rating will not be applied to Products. Please take special care under dry condition (e.g. Grounding of human body / equipment / solder iron, isolation from charged objects, setting of Ionizer, friction prevention and temperature / humidity control).

Precaution for Storage / Transportation

1. Product performance and soldered connections may deteriorate if the Products are stored in the places where:
 - [a] the Products are exposed to sea winds or corrosive gases, including Cl₂, H₂S, NH₃, SO₂, and NO₂
 - [b] the temperature or humidity exceeds those recommended by ROHM
 - [c] the Products are exposed to direct sunshine or condensation
 - [d] the Products are exposed to high Electrostatic
2. Even under ROHM recommended storage condition, solderability of products out of recommended storage time period may be degraded. It is strongly recommended to confirm solderability before using Products of which storage time is exceeding the recommended storage time period.
3. Store / transport cartons in the correct direction, which is indicated on a carton with a symbol. Otherwise bent leads may occur due to excessive stress applied when dropping of a carton.
4. Use Products within the specified time after opening a humidity barrier bag. Baking is required before using Products of which storage time is exceeding the recommended storage time period.

Precaution for Product Label

A two-dimensional barcode printed on ROHM Products label is for ROHM's internal use only.

Precaution for Disposition

When disposing Products please dispose them properly using an authorized industry waste company.

Precaution for Foreign Exchange and Foreign Trade act

Since concerned goods might be fallen under listed items of export control prescribed by Foreign exchange and Foreign trade act, please consult with ROHM in case of export.

Precaution Regarding Intellectual Property Rights

1. All information and data including but not limited to application example contained in this document is for reference only. ROHM does not warrant that foregoing information or data will not infringe any intellectual property rights or any other rights of any third party regarding such information or data.
2. ROHM shall not have any obligations where the claims, actions or demands arising from the combination of the Products with other articles such as components, circuits, systems or external equipment (including software).
3. No license, expressly or implied, is granted hereby under any intellectual property rights or other rights of ROHM or any third parties with respect to the Products or the information contained in this document. Provided, however, that ROHM will not assert its intellectual property rights or other rights against you or your customers to the extent necessary to manufacture or sell products containing the Products, subject to the terms and conditions herein.

Other Precaution

1. This document may not be reprinted or reproduced, in whole or in part, without prior written consent of ROHM.
2. The Products may not be disassembled, converted, modified, reproduced or otherwise changed without prior written consent of ROHM.
3. In no event shall you use in any way whatsoever the Products and the related technical information contained in the Products or this document for any military purposes, including but not limited to, the development of mass-destruction weapons.
4. The proper names of companies or products described in this document are trademarks or registered trademarks of ROHM, its affiliated companies or third parties.

General Precaution

1. Before you use our Products, you are requested to carefully read this document and fully understand its contents. ROHM shall not be in any way responsible or liable for failure, malfunction or accident arising from the use of any ROHM's Products against warning, caution or note contained in this document.
2. All information contained in this document is current as of the issuing date and subject to change without any prior notice. Before purchasing or using ROHM's Products, please confirm the latest information with a ROHM sales representative.
3. The information contained in this document is provided on an "as is" basis and ROHM does not warrant that all information contained in this document is accurate and/or error-free. ROHM shall not be in any way responsible or liable for any damages, expenses or losses incurred by you or third parties resulting from inaccuracy or errors of or concerning such information.