

Driver IC for PPC

# High Performance, High Reliability 50V DC Brush Motor Driver for PPC's others

**BD63130AFM**

**General Description**

BD63130AFM is one H-bridge motor driver for DC brush motor. This driver can facilitate low power consumption by direct PWM or PWM constant current control. There are built in protection circuits in this IC. It is possible to output an abnormal detection signal for Wired-OR that notifies each protection circuit operation, which contributes to set high reliability.

**Features**

- Single Power Supply Input (rated voltage of 50V)
- Rated Output Current (peak): 3.0A(4.0A)
- Low ON-Resistance DMOS Output
- Forward, Reverse, Brake, Open
- Power Save Function
- External PWM Control
- PWM Constant Current Control (current limit function)
- Built-in Spike Noise Cancel Function (external noise filter is unnecessary)
- Driver for DC Brush Motor
- Built-in Logic Input Pull-down Resistor
- Cross-conduction Prevention Circuit
- Output Detection Signal during Abnormal states (Wired-OR)
- Thermal Shutdown Circuit (TSD)
- Over-current Protection Circuit (OCP)
- Under Voltage Lock out Circuit (UVLO)
- Over Voltage Lock out Circuit (OVLO)
- Ghost Supply Prevention (protects against malfunction when power supply is disconnected)
- HSOP-M36 package

**Application**

- Plain Paper Copier (PPC), Multi-function Printer, Laser Printer, Inkjet Printer, Photo Printer, FAX, Mini Printer and etc.

**Key Specifications**

- Power Supply Voltage Range: 8.0V to 46.2V
- Rated Output Current: 3.0A
- Rated Output Current (Peak): 4.0A
- Operating Temperature Range: -25°C to +85°C
- Output ON-Resistance: 0.55Ω(Typ)  
(Total of upper and lower resistors)

**Package**

HSOP-M36

W(Typ) x D(Typ) x H(Max)  
18.50mm x 9.90mm x 2.40mm



Figure 1. HSOP-M36

**Typical Application Circuit**

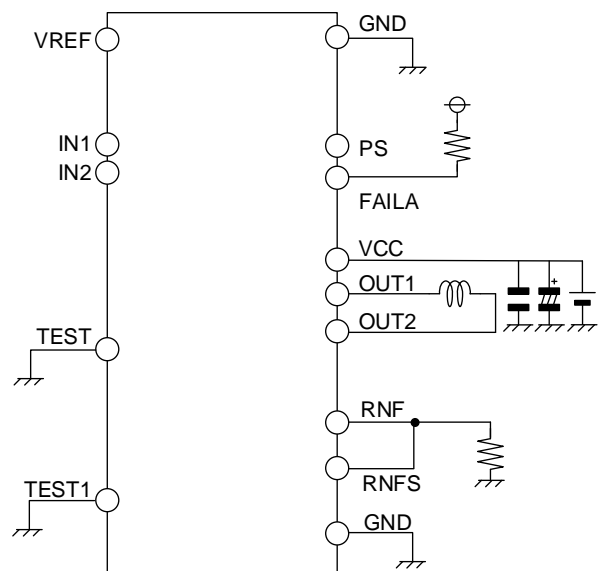

Figure 2. Application Circuit

○Product structure : silicon monolithic integrated circuit ○This product has no designed protection against radioactive rays.

Pin Configuration

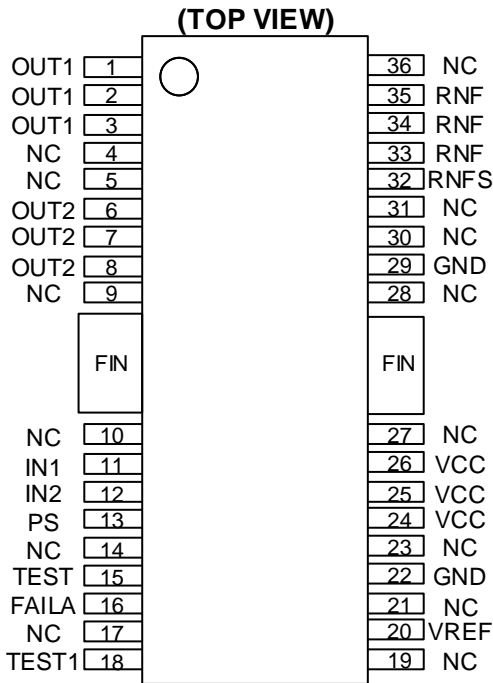

Figure 3. Pin Configuration

Block Diagram

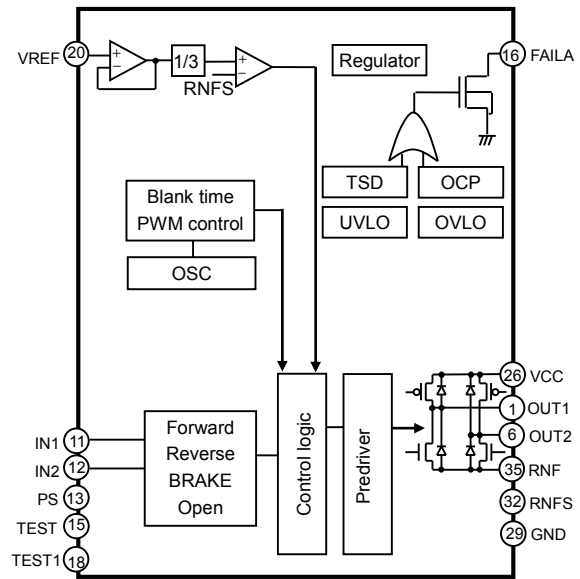

Figure 4. Block Diagram

Pin Descriptions

Pin No.	Pin Name	Function	Pin No.	Pin Name	Function
1	OUT1	H bridge output pin	19	NC	Non-connection
2	OUT1		20	VREF	Current limit setting pin
3	OUT1		21	NC	Non-connection
4	NC	Non-connection	22	GND	Ground pin
5	NC	Non-connection	23	NC	Non-connection
6	OUT2	H bridge output pin	24	VCC	Power supply pin
7	OUT2		25	VCC	
8	OUT2		26	VCC	
9	NC	Non-connection	27	NC	Non-connection
FIN	FIN	Fin pin (used by connecting with GND)	FIN	FIN	Fin pin (used by connecting with GND)
10	NC	Non-connection	28	NC	Non-connection
11	IN1	H bridge control pin	29	GND	Ground pin
12	IN2	H bridge control pin	30	NC	Non-connection
13	PS	Power save pin	31	NC	Non-connection
14	NC	Non-connection	32	RNFS	Input pin of current detection comparator
15	TEST	Pin for testing (used by connecting with GND)	33	RNF	Connection pin of resistor for output current detection
16	FAILA	Output signal to detect abnormal states	34	RNF	
17	NC	Non-connection	35	RNF	
18	TEST1	Pin for testing (used by connecting with GND)	36	NC	Non-connection

**Absolute Maximum Ratings (Ta=25°C)**

Parameter	Symbol	Rating	Unit
Supply Voltage	V <sub>CC</sub>	-0.2 to +50.0	V
Input Voltage for Control Pin	V <sub>IN</sub>	-0.2 to +5.5	V
RNF Maximum Voltage	V <sub>RNF</sub>	0.7	V
Output Current	I <sub>OUT</sub>	3.0 <sup>(Note 1)</sup>	A/ch
Output Current (PEAK) <sup>(Note 2)</sup>	I <sub>OUTPEAK</sub>	4.0 <sup>(Note 1)</sup>	A/ch
Output Current (BRAKE) <sup>(Note 3)</sup>	I <sub>OUTBRAKE</sub>	6.0 <sup>(Note 1)</sup>	A/ch
Storage Temperature Range	T <sub>stg</sub>	-55 to +150	°C
Maximum Junction Temperature	T <sub>jmax</sub>	+150	°C

(Note 1) Do not, however exceed T<sub>jmax</sub>=150°C.

(Note 2) 2s or under and duty 20% over 3A.

(Note 3) This current is flowed switching from forward rotation and reverse rotation to the brake mode.

**Caution 1:** Operating the IC over the absolute maximum ratings may damage the IC. The damage can either be a short circuit between pins or an open circuit between pins and the internal circuitry. Therefore, it is important to consider circuit protection measures, such as adding a fuse, in case the IC is operated over the absolute maximum ratings.

**Caution 2:** Should by any chance the maximum junction temperature rating be exceeded the rise in temperature of the chip may result in deterioration of the properties of the chip. In case of exceeding this absolute maximum rating, design a PCB boards with thermal resistance taken into consideration by increasing board size and copper area so as not to exceed the maximum junction temperature rating.

**Recommended Operating Conditions**

Parameter	Symbol	Range	Unit
Operating Temperature Range	T <sub>opr</sub>	-25 to +85	°C
Supply Voltage	V <sub>CC</sub>	8.0 to 46.2	V
Maximum Output Current (Continuous)	I <sub>OUT</sub>	2.0 <sup>(Note 4)</sup>	A/ch

(Note 4) Do not, however exceed T<sub>jmax</sub>=150°C.

**Thermal Resistance<sup>(Note 5)</sup>**

Parameter	Symbol	Thermal Resistance (Typ)		Unit
		1s <sup>(Note 7)</sup>	2s2p <sup>(Note 8)</sup>	
HSOP-M36				
Junction to Ambient	θ <sub>JA</sub>	53.9	26.4	°C/W
Junction to Top Characterization Parameter <sup>(Note 6)</sup>	Ψ <sub>JT</sub>	3	2	°C/W

(Note 5) Based on JESD51-2A(Still-Air).

(Note 6) The thermal characterization parameter to report the difference between junction temperature and the temperature at the top center of the outside surface of the component package.

(Note 7) Using a PCB board based on JESD51-3.

(Note 8) Using a PCB board based on JESD51-7.

Layer Number of Measurement Board	Material	Board Size			
Single	FR-4	114.3mm x 76.2mm x 1.57mmt			
Top					
Copper Pattern	Thickness				
Footprints and Traces	70µm				
Layer Number of Measurement Board					
4 Layers	FR-4	114.3mm x 76.2mm x 1.6mmt			
Top		2 Internal Layers	Bottom		
Copper Pattern	Thickness	Copper Pattern	Thickness	Copper Pattern	Thickness
Footprints and Traces	70µm	74.2mm x 74.2mm	35µm	74.2mm x 74.2mm	70µm

Electrical Characteristics (Unless otherwise specified Ta=25°C, V<sub>CC</sub>=24V)

Parameter	Symbol	Limit			Unit	Conditions
		Min	Typ	Max		
【Whole】						
Circuit Current at Standby	I <sub>CCST</sub>	-	-	10	μA	PS=L
Circuit Current	I <sub>CC</sub>	-	2.5	5.0	mA	PS=H, VREF=2V
【Control Input】						
H Level Input Voltage	V <sub>INH</sub>	2.0	-	-	V	
L Level Input Voltage	V <sub>INL</sub>	-	-	0.8	V	
H Level Input Current	I <sub>INH</sub>	35	50	100	μA	V <sub>IN</sub> =5V
L Level Input Current	I <sub>INL</sub>	-10	0	-	μA	V <sub>IN</sub> =0V
【Output (OUT1, OUT2)】						
Output ON-Resistance	R <sub>ON</sub>	-	0.55	0.72	Ω	I <sub>OUT</sub> = ±2.0A (Sum of upper and lower)
Output Leak Current	I <sub>LEAK</sub>	-	-	10	μA	
【Current Control】						
RNF Input Current	I <sub>RNF</sub>	-80	-40	-	μA	RNF=0V
VREF Input Current	I <sub>VREF</sub>	-2.0	-0.1	-	μA	VREF=0V
VREF Input Voltage Range	V <sub>VREF</sub>	-	-	2.0	V	
Minimum on Time (Blank Time)	t <sub>ONMIN</sub>	0.7	1.5	3.0	μs	
Comparator Threshold	V <sub>CTH</sub>	0.475	0.500	0.525	V	VREF=1.5V

**Application Information**

Points to Notice for Pin Description and PCB Layout

(1) PS/ Power Save Pin

PS can make circuit into standby state and make motor outputs OPEN.

Be careful because there is a delay of 40μs(Max), as PS=L→H, until it is returned from standby state to normal state and the motor output becomes ACTIVE.

PS	State
L	POWER SAVE (STANDBY)
H	ACTIVE

(2) IN1, IN2/ H Bridge Control Pin

It decides output logic for H bridge.

Input			Output		State
PS	IN1	IN2	OUT1	OUT2	
L	x	x	OPEN	OPEN	POWER SAVE (STANDBY)
H	L	L	OPEN	OPEN	STOP
H	H	L	H	L	FORWARD
H	L	H	L	H	REVERSE
H	H	H	L	L	BRAKE

x : H or L

(3) TEST, TEST1/ Pin for Testing

This is the pin used at the time of distribution test. Connect to GND. Be careful because there is a possibility of malfunction if it is not connected to GND.

(4) VCC/ Power Supply Pin

Motor's drive current is flowing in it, so the wire is thick, short and has low impedance. Voltage VCC may have great fluctuation, so arrange the bypass capacitor of about 100μF to 470μF as close to the pin as possible and adjust the voltage VCC is stable. Increase the capacity as needed especially, when a large current is used or those motors that have great back electromotive force are used.

In addition, for the purpose of reducing of power supply's impedance in wideband, it is recommended to set parallel connection of multi-layered ceramic capacitor of 0.01μF to 0.1μF etc. Extreme care must be used to make sure that the voltage VCC does not exceed the rating even for a moment. Still more, in the power supply pin, there is built-in clamp component for preventing of electrostatic destruction. When a steep pulse signal or voltage such as a surge exceeding the absolute maximum rating is applied, this clamp component operates, as a result there is the danger of destruction, so be sure that the absolute maximum rating must not be exceeded. It is effective to mount a Zener diode of about the absolute maximum rating. Moreover, the diode for preventing of electrostatic destruction is inserted between VCC pin and GND pin, as a result there is the danger of IC destruction if reverse voltage is applied between VCC pin and GND pin, so be careful.

(5) GND/ Ground Pin

In order to reduce the noise caused by switching current and to stabilize the internal reference voltage of IC, the wiring impedance from this pin is made as low as possible to achieve the lowest electrical potential no matter what operating state it may be. Moreover, design patterns not to have any common impedance with other GND patterns.

(6) OUT1, OUT2/ H Bridge Output Pin

Motor's drive current is flowing in it, so the wire is thick, short and has low impedance. It is also effective to add a Schottky diode if output has positive or negative great fluctuation when large current is used. For example, counter electromotive voltage etc. Moreover, in the output pin, there is built-in clamp component for preventing of electrostatic destruction. When a steep pulse signal or voltage such as a surge exceeding the absolute maximum rating is applied, this clamp component operates, as a result there is the danger of even destruction, so be sure that the absolute maximum rating must not exceeded.

(7) RNF/ Connection Pin of Resistor for Detecting of Output Current

Connect the resistor of 0.1Ω to 0.3Ω for current detection between this pin and GND. Determine the resistor so that power consumption  $W=I_{OUT}^2 \cdot R$  [W] of the current-detecting resistor does not exceed the power dissipation of the resistor. In addition, it has a low impedance and does not have a common impedance with other GND patterns because motor's drive current flows in the pattern through RNF Pin to current-detecting resistor to GND. Do not exceed the rating because there is the possibility of circuits' malfunction etc., if RNF voltage has exceeded the maximum rating (0.7V). If RNF pin is open, then there is the possibility of such malfunction as output current does not flow either, so do not let it open.

**Application Information – continued**

(8) RNFS/ Input Pin of Current detection Comparator

In this series, RNFS pin, which is the input pin of current detection comparator, is independently arranged in order to decrease the lowering of current-detecting accuracy caused by the wire impedance inside the IC of RNF pin. Therefore, be sure to connect RNF pin and RNFS pin together when using in the case of PWM constant current control. In addition, because the wires from RNFS pin is connected near the current-detecting resistor in the case of interconnection, the lowering of current-detecting accuracy, which is caused by the impedance of board pattern between RNF pin and the current-detecting resistor, can be decreased. Moreover, design the pattern there is no noise plunging.

(9) VREF/ Output Current limit setting Pin

[When to use current limit]

This is the pin to set the current limit value. It can be set by VREF voltage and current-detecting resistor (RNF resistor).

$$I_{OUT} = \frac{VREF}{3} / RNF \quad [A]$$

Where:

*I<sub>OUT</sub>* is the output current.

*VREF* is the voltage of output current limit setting.

*RNF* is the current-detecting resistor.

Avoid using it with VREF pin open because if VREF pin is open, the input is unsettled, and the VREF voltage increases, and then there is the possibility of such malfunctions as the setting current increases and a large current flows etc. Keep to the input voltage range because if the voltage of 2V or more is applied on VREF pin, then there is also the danger that a large current flows in the output and so OCP or TSD will operate. Besides, select the resistance value in consideration of the outflow current (Max 2μA) if it is inputted by resistance division. The minimum current, which can be controlled by VREF voltage, is determined by motor coil's L, R values and minimum ON time because there is a minimum ON time in PWM drive.

[When not to use current limit]

Short RNF pin with the GND. However, there is a possibility of PWM constant current control depending on the impedance of board pattern. For the reason, when not to use PWM constant current control, input 1V to 2V to VREF pin ([Refer to figure 8.](#)).

(10) FAILA/ Fault Signal Output Pin

FAILA outputs abnormality detection signal when Over-Current Protection (OCP) or Thermal Shutdown (TSD) operates. Even if Under Voltage Lock Out (UVLO) or Over Voltage Lock Out (OVLO) operates, FAILA signal doesn't turn abnormality detection signal (i.e. high). This signal can be connected to the microcomputer and the system can be shut down.

This pin is an open drain type, so set the pull up resistor (5kΩ to 100kΩ) to power supply 7V or less (i.e. 5V or 3.3V). If not using this pin, connect it to GND.

OCP	TSD	FAILA
OFF	OFF	H (OFF)
OFF	ON	M (ON)
ON	OFF	L (ON)
ON	ON	L (ON)

(11) NC Pin

This pin is unconnected electrically with IC internal circuit.

(12) FIN Pin

HSOP-M36 package is mounted with the heat-radiating FIN pin, and be sure to connect the metal by solder with the GND on the board and get as wide GND pattern as possible. Be careful because Thermal Resistance is increasing if not connected by solder.

Moreover, the FIN pin is shorted with IC chip's back side and becomes the GND potential, so there is the danger of malfunction and destruction if shorted with potentials other than GND. Therefore, absolutely do not connect with potentials other than GND.

## Protection Circuits

### Thermal Shutdown (TSD)

This IC has a built-in Thermal Shutdown circuit for thermal protection. When the IC's chip temperature rises 175°C (Typ) or more, the motor output becomes OPEN. Also, when the temperature returns to 150°C (Typ) or less, it automatically returns to normal operation. However, even when TSD is in operation, if heat is continued to be applied externally, heat overdrive can lead to destruction.

### Over-Current Protection (OCP)

This IC has a built in Over-Current Protection circuit as a provision against destruction when the motor outputs are shorted to each other or VCC-motor output or motor output-GND is shorted. This circuit latches the motor output to OPEN condition when the regulated current flows for 4μs (Typ). It returns with power reactivation or a reset of the PS pin. The over-current protection circuit aims to prevent the destruction of the IC only from abnormal situations such as when motor output is shorted and it is not meant to be used as protection or security for the device. Therefore, the device should not be designed to make use of the function of this circuit. After OCP operation, if abnormal situations continue and returned by power reactivation or reset of the PS pin happens repeatedly, then OCP operates constantly. The IC may generate heat or otherwise deteriorate. When the L value of the wiring is great due to the wiring being long, if the output pin voltage jumps up and the absolute maximum values may be exceeded after the over current has flowed, there is a possibility of destruction. Also when current which is the output current rating or more and the OCP detection current or less flows, the IC can heat up to Tjmax=150°C or more and can deteriorate, so current which exceeds the output rating should not be applied.

### Under Voltage Lock Out (UVLO)

This IC has a built-in Under Voltage Lock Out function to prevent false operation such as IC output during power supply under voltage. When the applied voltage to the VCC pin goes 5V (Typ) or less, the motor output is set to OPEN. This switching voltage has a 1V (Typ) hysteresis to prevent false operation by noise etc. Be aware that this protection circuit does not operate during power save mode.

### Over Voltage Lock Out (OVLO)

This IC has a built-in Over Voltage Lock Out function to protect the IC output and the motor during power supply over voltage. When the applied voltage to the VCC pin goes 52V (Typ) or more, the motor output is set to OPEN. This switching voltage has a 1V (Typ) hysteresis and a 4μs (Typ) mask time to prevent false operation by noise etc. Although this over voltage locked out circuit is built-in, there is a possibility of destruction if the absolute maximum value for power supply voltage is exceeded. Therefore, the absolute maximum value should not be exceeded. Be aware that this protection circuit does not operate during power save mode.

### Ghost Supply Prevention (protects against malfunction when power supply is disconnected)

If a control signal (IN1, IN2, PS, and VREF) is applied when there is no power supplied to the IC, there is a function which prevents a malfunction where voltage is supplied to power supply of this IC or other IC in the set via the electrostatic destruction prevention diode from these input pins to the VCC. Therefore, there is no malfunction in the circuit even when voltage is supplied to these input pin while there is no power supply.

### Operation Under Strong Electromagnetic Field

The IC is not designed for using in the presence of strong electromagnetic field. Be sure to confirm that no malfunction is found when using the IC in a strong electromagnetic field.

**Direct PWM Control**

This series can control PWM by IN1, IN2 input directly from the microcomputer (up to 100kHz).

Decay mode can be SLOW DECAY or FAST DECAY.

Below are examples of control sequence and current decay path.

**SLOW DECAY (forward rotation)**

PS	Input		Output		State
	IN1	IN2	OUT1	OUT2	
H	H	L	H	L	ON
H	H	H	L	L	SLOW DECAY
H	H	L	H	L	ON
H	H	H	L	L	SLOW DECAY
H	H	L	H	L	ON

**FAST DECAY (synchronous rectification, forward rotation)**

PS	Input		Output		State
	IN1	IN2	OUT1	OUT2	
H	H	L	H	L	ON
H	L	H	L	H	FAST DECAY
H	H	L	H	L	ON
H	L	H	L	H	FAST DECAY
H	H	L	H	L	ON

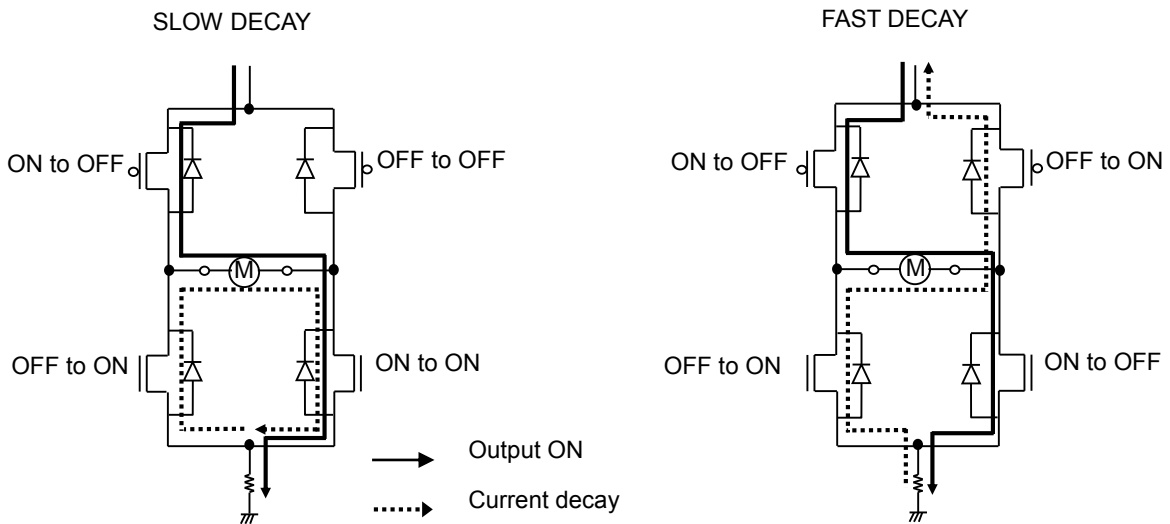

Figure 5. Route of Regenerative Current during Current Decay



**PWM Constant Current Control**

This function can limit the peak current such as switching current in driving DC brush motor.

(1) Current Control Operation

The output current increases due to the output transistor turned on. When the voltage on the RNF pin, the output current is converted it due to connect the external resistance to RNF pin, reaches the voltage value set by the VREF input voltage, the current limit comparator engages and enters current decay mode. Thereafter the output turned on again after a period of time determined the CR pin. The process repeats itself constantly.

(2) Blank Time (Fixed in Internal Circuit)

In order to avoid misdetection of current detection comparator due to RNF spikes that occur when the output turns ON, the internal voltage between 0.4V and 0.8V is provided as minimum ON time ( $t_{ONMIN}$  1.5 $\mu$ s Typ). During this time, the current detection is disabled after the output transistor is turned on. This allows for constant-current drive without the need for an external filter.

(3) Internal Timer (Fixed in Internal Circuit)

Repeat charging and discharging between 0.4V to 0.9V internal voltage determined by IC internal circuit. When internal voltage is changed charge from discharge, the output is then ON from the current decay mode.

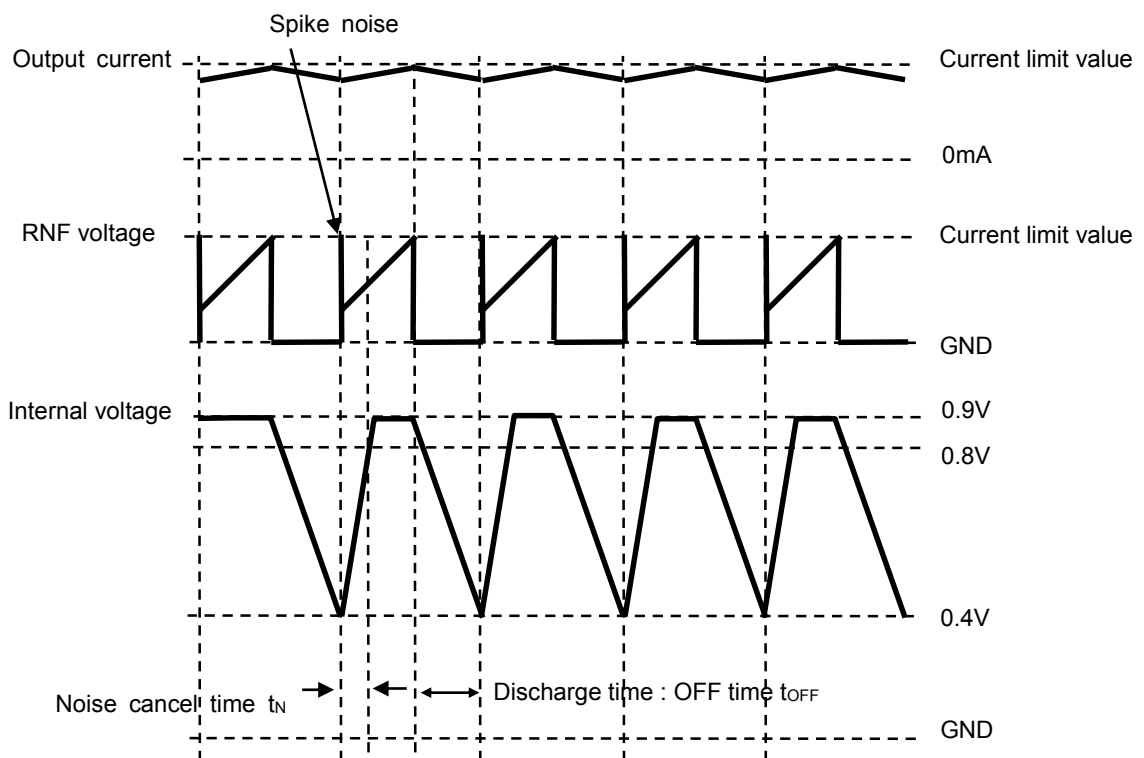

Figure 6. Timing Chart of Internal Voltage, RNF Voltage and Output Current

**Power Dissipation**

Confirm that the IC's chip temperature  $T_j$  is not over  $150^{\circ}\text{C}$  in consideration of the IC's power consumption ( $W$ ), thermal resistance ( $^{\circ}\text{C}/\text{W}$ ) and ambient temperature ( $T_a$ ). When  $T_j=150^{\circ}\text{C}$  is exceeded, the functions as a semiconductor do not operate and problems such as parasitism and leaks occur. Constant use under these circumstances leads to deterioration and eventually destruction of the IC.  $T_{j\text{max}}=150^{\circ}\text{C}$  must be strictly obeyed under all circumstances.

(1) Thermal Calculation

The IC's consumed power can be estimated roughly with the power supply voltage ( $V_{CC}$ ), circuit current ( $I_{CC}$ ), output ON-Resistance ( $R_{ONH}$ ,  $R_{ONL}$ ) and motor output current value ( $I_{OUT}$ ).

The calculation method during direct PWM drive, SLOW DECAY is shown here:

$$W_{VCC} = V_{CC} \times I_{CC} \quad [\text{W}]$$

where:

$W_{VCC}$  is the consumed power of the  $V_{CC}$ .

$V_{CC}$  is the power supply voltage.

$I_{CC}$  is the circuit current.

$$W_{DMOS} = W_{ON} + W_{DECAY} \quad [\text{W}]$$

$$W_{ON} = (R_{ONH} + R_{ONL}) \times I_{OUT}^2 \times \frac{\text{on\_duty}}{100} \quad [\text{W}]$$

$$W_{DECAY} = (2 \times R_{ONL}) \times I_{OUT}^2 \times \frac{100 - \text{on\_duty}}{100} \quad [\text{W}]$$

where:

$W_{DMOS}$  is the consumed power of the output DMOS.

$W_{ON}$  is the consumed power during output ON.

$W_{DECAY}$  is the consumed power during current decay.

$R_{ONH}$  is the upper P-channel DMOS ON-resistance.

$R_{ONL}$  is the lower N-channel DMOS ON-resistance.

$I_{OUT}$  is the motor output current value

$\text{on\_duty}$  PWM on duty[%]

Model Number	Upper P-Channel DMOS ON-Resistance $R_{ONH}[\Omega]$ (Typ)	Lower N-Channel DMOS ON-Resistance $R_{ONL}[\Omega]$ (Typ)
BD63130AFM	0.32	0.23

$$W_{total} = W_{VCC} + W_{DMOS} \quad [\text{W}]$$

$$T_j = T_a + \theta_{ja} \times W_{total} \quad [^{\circ}\text{C}]$$

where:

$W_{total}$  is the consumed total power of IC.

$T_j$  is the junction temperature.

$T_a$  is the air temperature.

$\theta_{ja}$  is the thermal resistance value.

However, the thermal resistance value  $\theta_{ja}$  [ $^{\circ}\text{C}/\text{W}$ ] differs greatly depending on circuit board conditions. The calculated values above are only theoretical. For actual thermal design, perform sufficient thermal evaluation for the application board used, and create the thermal design with enough margin to not exceed  $T_{j\text{max}}=150^{\circ}\text{C}$ . Although unnecessary with normal use, if the IC is to be used under especially strict heat conditions, consider externally attaching a Schottky diode between the motor output pin and GND to abate heat from the IC.

**Power Dissipation – continued**

(2) Temperature Monitoring

There is a way to directly measure the approximate chip temperature by using the TEST pin. However, temperature monitor using TEST pin is only for evaluation and experimenting, and must not be used in actual usage conditions. TEST pin has a protection diode to prevent electrostatic discharge. The temperature can be monitored using this protection diode.

- (a) Measure the pin voltage when a current of  $I_{DIODE}=50\mu A$  flows from the TEST pin to the GND, without supplying VCC to the IC. This measurement is the  $V_F$  voltage inside the diode.
- (b) Measure the temperature characteristics of this pin voltage. ( $V_F$  has a linear negative temperature factor against the temperature.) With the results of these temperature characteristics, chip temperature can be calibrated from the TEST pin voltage.
- (c) Supply VCC, confirm the TEST pin voltage while running the motor, and the chip temperature can be approximated from the results of (b).

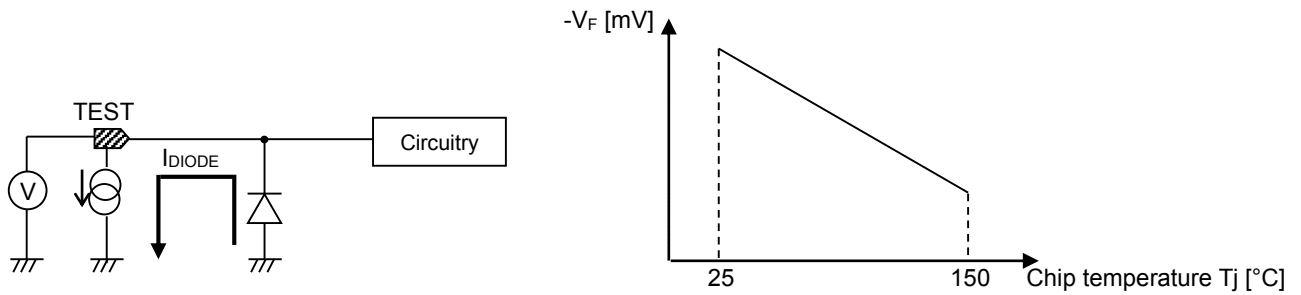

Figure 7. Model Diagram for Measuring Chip Temperature

Application Circuit Diagram

(1) Constant Voltage Control or External PWM Control

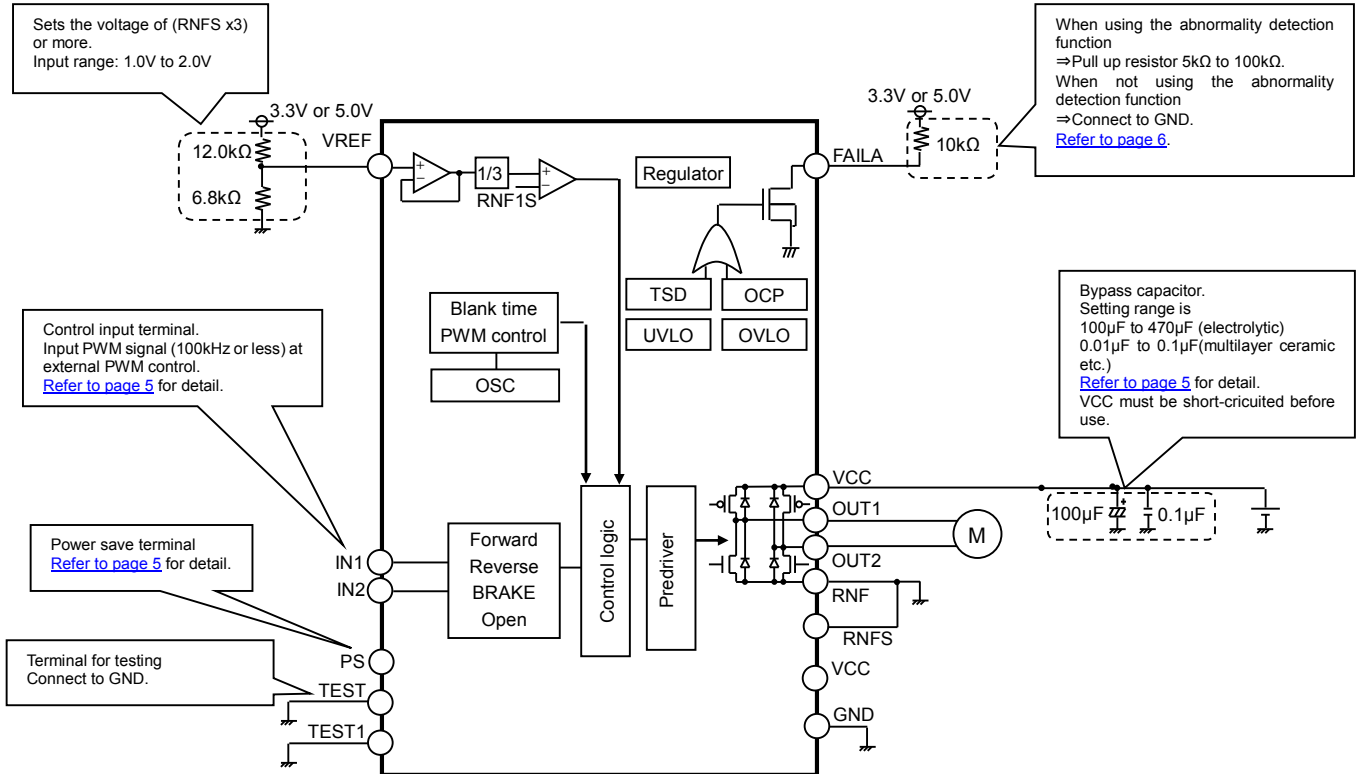

Figure 8. Constant Voltage Control or External PWM Control

(a) Input/ Output table

Input			Output		State
PS	IN1	IN2	OUT1	OUT2	
L	x	x	OPEN	OPEN	POWER SAVE (STANDBY)
H	L	L	OPEN	OPEN	STOP
H	H	L	H	L	FORWARD
H	L	H	L	H	REVERSE
H	H	H	L	L	BRAKE

x : H or L

(b) Example of external PWM control sequence  
SLOW DECAY (forward rotation)

Input			Output		State
PS	IN1	IN2	OUT1	OUT2	
H	H	L	H	L	ON
H	H	H	L	L	SLOW DECAY
H	H	L	H	L	ON
H	H	H	L	L	SLOW DECAY
H	H	L	H	L	ON

FAST DECAY (forward rotation)

Input			Output		State
PS	IN1	IN2	OUT1	OUT2	
H	H	L	H	L	ON
H	L	H	L	H	FAST DECAY
H	H	L	H	L	ON
H	L	H	L	H	FAST DECAY
H	H	L	H	L	ON

Application Circuit Diagram – continued

(2)PWM Constant Current Control

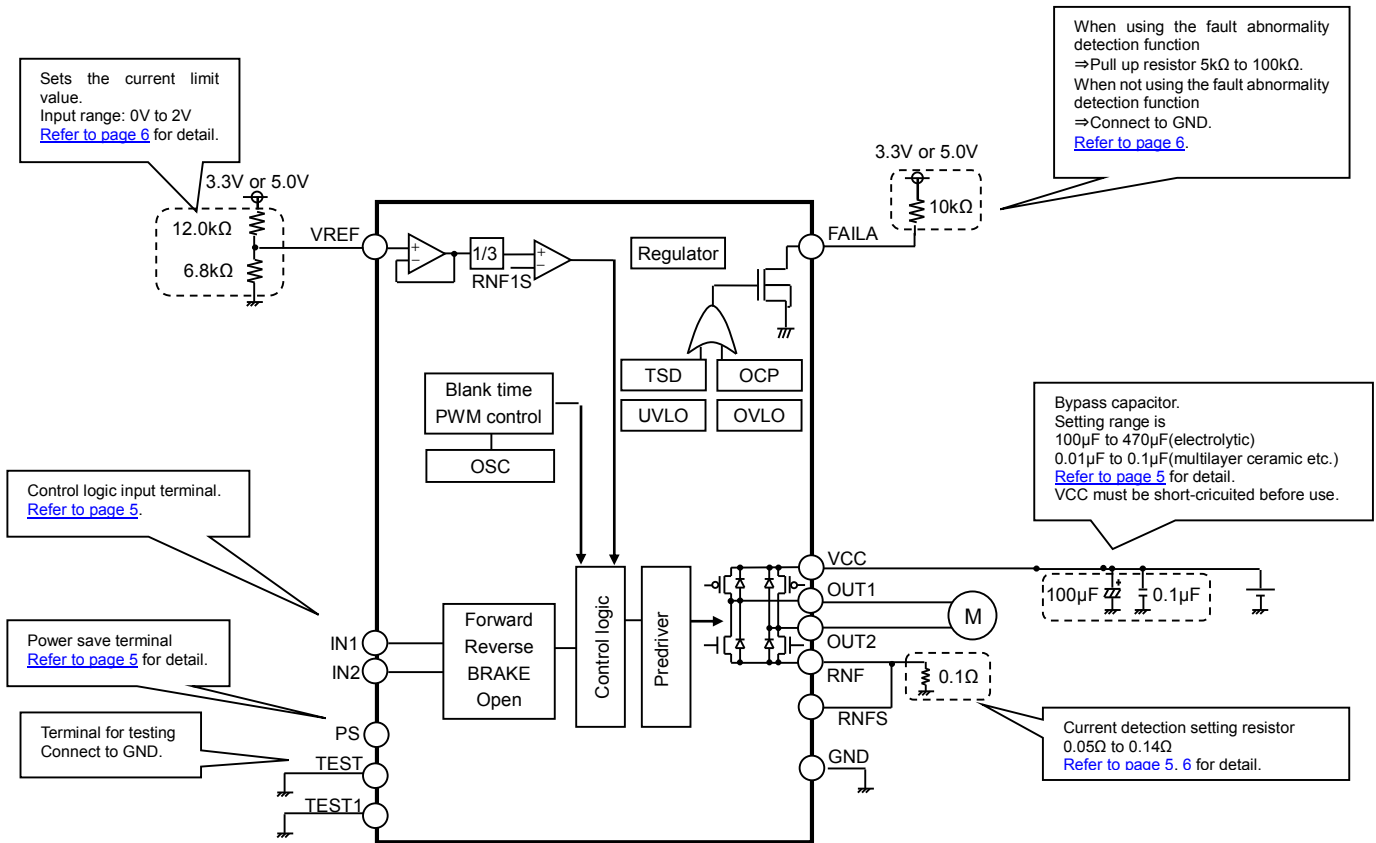

Figure 9. PWM Constant Current Control

(a) Input/ Output table

Input			Output		State
PS	IN1	IN2	OUT1	OUT2	
L	x	x	OPEN	OPEN	POWER SAVE (STANDBY)
H	L	L	OPEN	OPEN	STOP
H	H	L	H	L	FORWARD
H	L	H	L	H	REVERSE
H	H	H	L	L	BRAKE

x : H or L

I/O Equivalent Circuits

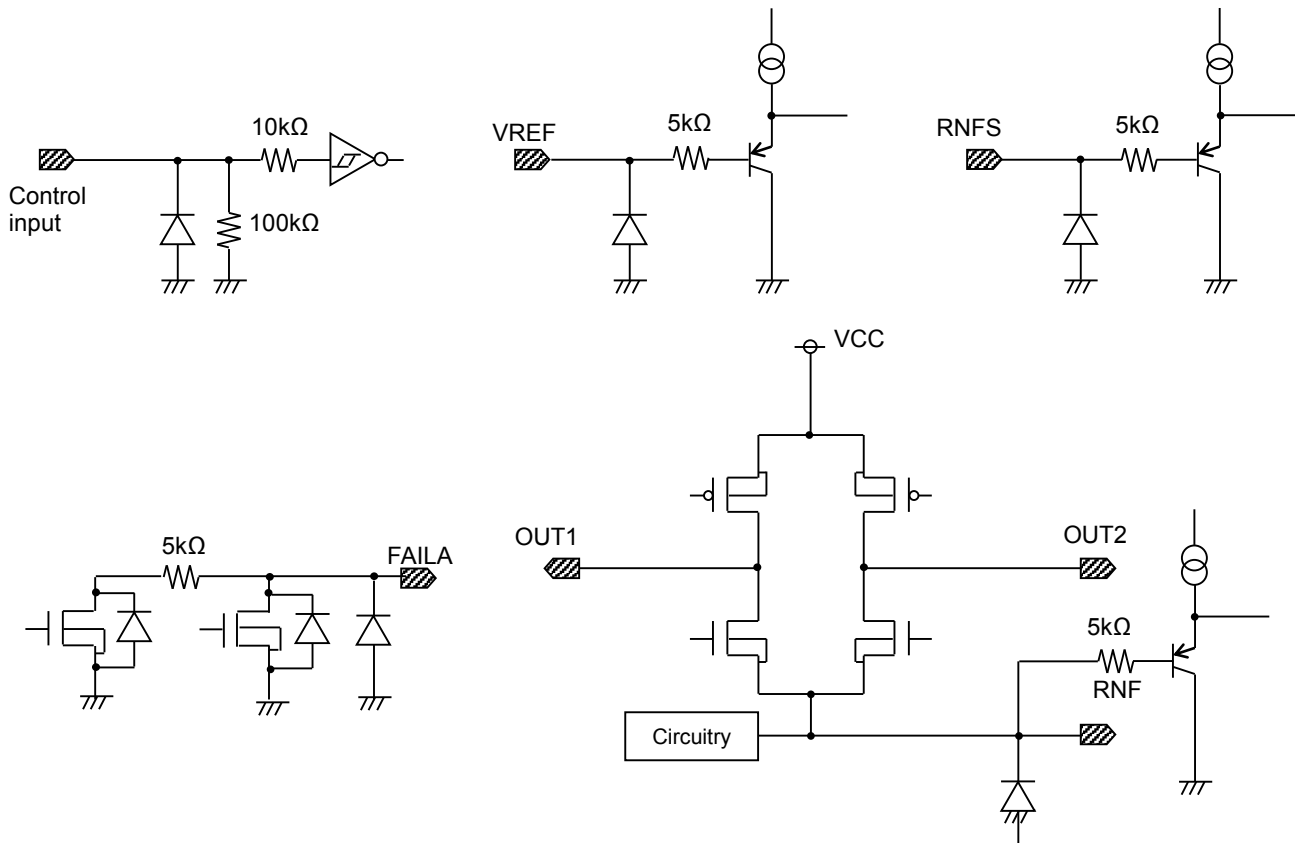

Figure 10. I/O Equivalent Circuits

## Operational Notes

1. **Reverse Connection of Power Supply**  
Connecting the power supply in reverse polarity can damage the IC. Take precautions against reverse polarity when connecting the power supply, such as mounting an external diode between the power supply and the IC's power supply pins.
2. **Power Supply Lines**  
Design the PCB layout pattern to provide low impedance supply lines. Furthermore, connect a capacitor to ground at all power supply pins. Consider the effect of temperature and aging on the capacitance value when using electrolytic capacitors.
3. **Ground Voltage**  
Ensure that no pins are at a voltage below that of the ground pin at any time, even during transient condition.
4. **Ground Wiring Pattern**  
When using both small-signal and large-current ground traces, the two ground traces should be routed separately but connected to a single ground at the reference point of the application board to avoid fluctuations in the small-signal ground caused by large currents. Also ensure that the ground traces of external components do not cause variations on the ground voltage. The ground lines must be as short and thick as possible to reduce line impedance.
5. **Recommended Operating Conditions**  
The function and operation of the IC are guaranteed within the range specified by the recommended operating conditions. The characteristic values are guaranteed only under the conditions of each item specified by the electrical characteristics.
6. **Inrush Current**  
When power is first supplied to the IC, it is possible that the internal logic may be unstable and inrush current may flow instantaneously due to the internal powering sequence and delays, especially if the IC has more than one power supply. Therefore, give special consideration to power coupling capacitance, power wiring, width of ground wiring, and routing of connections.
7. **Operation Under Strong Electromagnetic Field**  
Operating the IC in the presence of a strong electromagnetic field may cause the IC to malfunction.
8. **Testing on Application Boards**  
When testing the IC on an application board, connecting a capacitor directly to a low-impedance output pin may subject the IC to stress. Always discharge capacitors completely after each process or step. The IC's power supply should always be turned off completely before connecting or removing it from the test setup during the inspection process. To prevent damage from static discharge, ground the IC during assembly and use similar precautions during transport and storage.
9. **Inter-pin Short and Mounting Errors**  
Ensure that the direction and position are correct when mounting the IC on the PCB. Incorrect mounting may result in damaging the IC. Avoid nearby pins being shorted to each other especially to ground, power supply and output pin. Inter-pin shorts could be due to many reasons such as metal particles, water droplets (in very humid environment) and unintentional solder bridge deposited in between pins during assembly to name a few.
10. **Unused Input Pins**  
Input pins of an IC are often connected to the gate of a MOS transistor. The gate has extremely high impedance and extremely low capacitance. If left unconnected, the electric field from the outside can easily charge it. The small charge acquired in this way is enough to produce a significant effect on the conduction through the transistor and cause unexpected operation of the IC. So unless otherwise specified, unused input pins should be connected to the power supply or ground line.

Operational Notes – continued

11. Regarding the Input Pin of the IC

This monolithic IC contains P+ isolation and P substrate layers between adjacent elements in order to keep them isolated. P-N junctions are formed at the intersection of the P layers with the N layers of other elements, creating a parasitic diode or transistor. For example (refer to figure below):

When  $GND > Pin A$  and  $GND > Pin B$ , the P-N junction operates as a parasitic diode.  
 When  $GND > Pin B$ , the P-N junction operates as a parasitic transistor.

Parasitic diodes inevitably occur in the structure of the IC. The operation of parasitic diodes can result in mutual interference among circuits, operational faults, or physical damage. Therefore, conditions that cause these diodes to operate, such as applying a voltage lower than the GND voltage to an input pin (and thus to the P substrate) should be avoided.

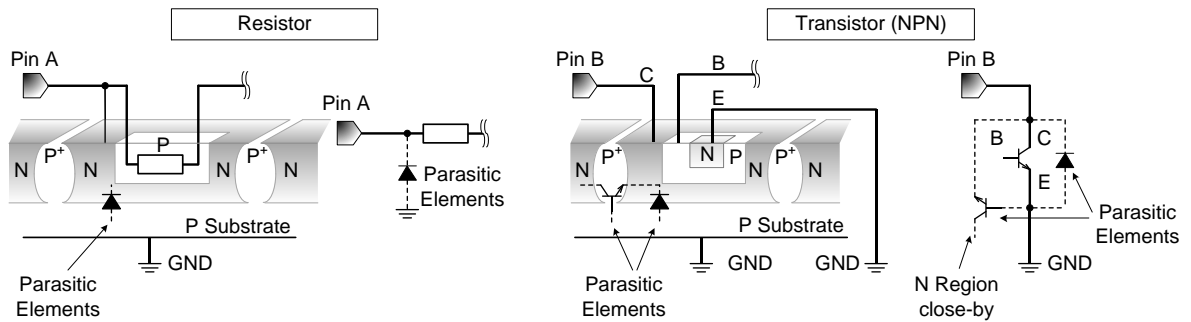

Figure 11. Example of monolithic IC structure

12. Thermal Shutdown Circuit(TSD)

This IC has a built-in thermal shutdown circuit that prevents heat damage to the IC. Normal operation should always be within the IC's maximum junction temperature rating. If however the rating is exceeded for a continued period, the junction temperature ( $T_j$ ) will rise which will activate the TSD circuit that will turn OFF power output pins. When the  $T_j$  falls below the TSD threshold, the circuits are automatically restored to normal operation.

Note that the TSD circuit operates in a situation that exceeds the absolute maximum ratings and therefore, under no circumstances, should the TSD circuit be used in a set design or for any purpose other than protecting the IC from heat damage.

13. Over Current Protection Circuit (OCP)

This IC incorporates an integrated overcurrent protection circuit that is activated when the load is shorted. This protection circuit is effective in preventing damage due to sudden and unexpected incidents. However, the IC should not be used in applications characterized by continuous operation or transitioning of the protection circuit.



Ordering Information

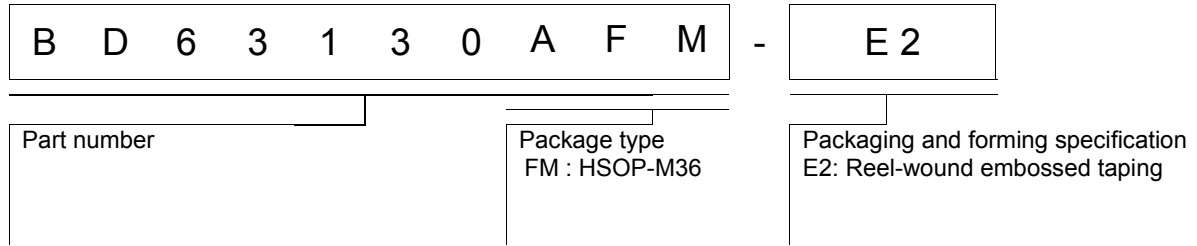

Marking Diagram

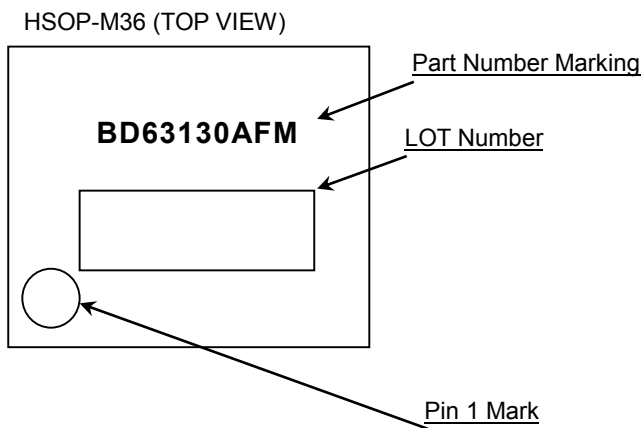

Physical Dimension and Packing Information

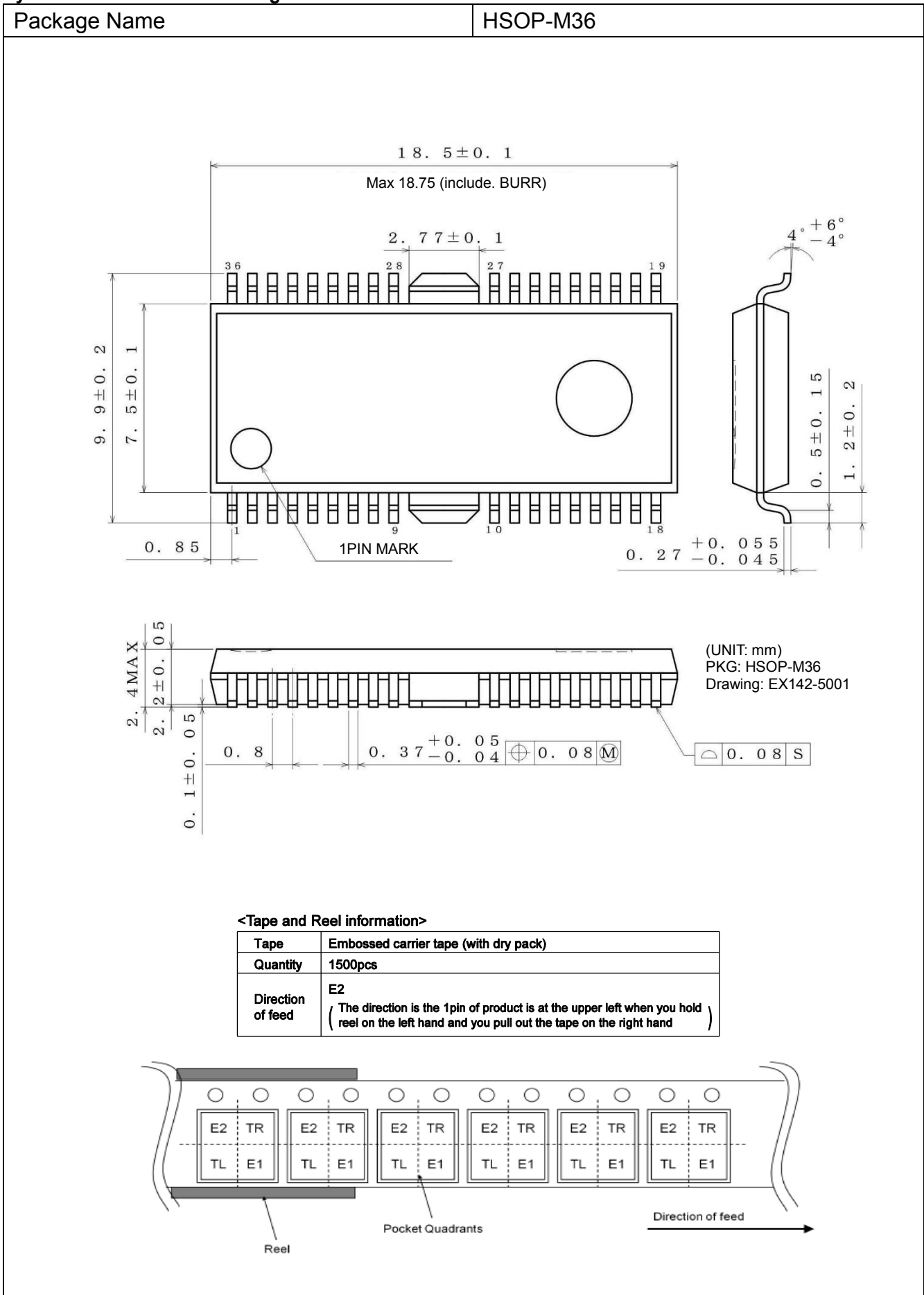

**Revision History**

Date	Revision	Changes
26.Dec.2017	001	New Release

# Notice

## Precaution on using ROHM Products

- Our Products are designed and manufactured for application in ordinary electronic equipment (such as AV equipment, OA equipment, telecommunication equipment, home electronic appliances, amusement equipment, etc.). If you intend to use our Products in devices requiring extremely high reliability (such as medical equipment <sup>(Note 1)</sup>, transport equipment, traffic equipment, aircraft/spacecraft, nuclear power controllers, fuel controllers, car equipment including car accessories, safety devices, etc.) and whose malfunction or failure may cause loss of human life, bodily injury or serious damage to property ("Specific Applications"), please consult with the ROHM sales representative in advance. Unless otherwise agreed in writing by ROHM in advance, ROHM shall not be in any way responsible or liable for any damages, expenses or losses incurred by you or third parties arising from the use of any ROHM's Products for Specific Applications.

(Note1) Medical Equipment Classification of the Specific Applications

JAPAN	USA	EU	CHINA
CLASS III	CLASS III	CLASS II b	CLASS III
CLASS IV		CLASS III	

- ROHM designs and manufactures its Products subject to strict quality control system. However, semiconductor products can fail or malfunction at a certain rate. Please be sure to implement, at your own responsibilities, adequate safety measures including but not limited to fail-safe design against the physical injury, damage to any property, which a failure or malfunction of our Products may cause. The following are examples of safety measures:
  - Installation of protection circuits or other protective devices to improve system safety
  - Installation of redundant circuits to reduce the impact of single or multiple circuit failure
- Our Products are designed and manufactured for use under standard conditions and not under any special or extraordinary environments or conditions, as exemplified below. Accordingly, ROHM shall not be in any way responsible or liable for any damages, expenses or losses arising from the use of any ROHM's Products under any special or extraordinary environments or conditions. If you intend to use our Products under any special or extraordinary environments or conditions (as exemplified below), your independent verification and confirmation of product performance, reliability, etc. prior to use, must be necessary:
  - Use of our Products in any types of liquid, including water, oils, chemicals, and organic solvents
  - Use of our Products outdoors or in places where the Products are exposed to direct sunlight or dust
  - Use of our Products in places where the Products are exposed to sea wind or corrosive gases, including Cl<sub>2</sub>, H<sub>2</sub>S, NH<sub>3</sub>, SO<sub>2</sub>, and NO<sub>2</sub>
  - Use of our Products in places where the Products are exposed to static electricity or electromagnetic waves
  - Use of our Products in proximity to heat-producing components, plastic cords, or other flammable items
  - Sealing or coating our Products with resin or other coating materials
  - Use of our Products without cleaning residue of flux (even if you use no-clean type fluxes, cleaning residue of flux is recommended); or Washing our Products by using water or water-soluble cleaning agents for cleaning residue after soldering
  - Use of the Products in places subject to dew condensation
- The Products are not subject to radiation-proof design.
- Please verify and confirm characteristics of the final or mounted products in using the Products.
- In particular, if a transient load (a large amount of load applied in a short period of time, such as pulse. is applied, confirmation of performance characteristics after on-board mounting is strongly recommended. Avoid applying power exceeding normal rated power; exceeding the power rating under steady-state loading condition may negatively affect product performance and reliability.
- De-rate Power Dissipation depending on ambient temperature. When used in sealed area, confirm that it is the use in the range that does not exceed the maximum junction temperature.
- Confirm that operation temperature is within the specified range described in the product specification.
- ROHM shall not be in any way responsible or liable for failure induced under deviant condition from what is defined in this document.

## Precaution for Mounting / Circuit board design

- When a highly active halogenous (chlorine, bromine, etc.) flux is used, the residue of flux may negatively affect product performance and reliability.
- In principle, the reflow soldering method must be used on a surface-mount products, the flow soldering method must be used on a through hole mount products. If the flow soldering method is preferred on a surface-mount products, please consult with the ROHM representative in advance.

For details, please refer to ROHM Mounting specification

### Precautions Regarding Application Examples and External Circuits

1. If change is made to the constant of an external circuit, please allow a sufficient margin considering variations of the characteristics of the Products and external components, including transient characteristics, as well as static characteristics.
2. You agree that application notes, reference designs, and associated data and information contained in this document are presented only as guidance for Products use. Therefore, in case you use such information, you are solely responsible for it and you must exercise your own independent verification and judgment in the use of such information contained in this document. ROHM shall not be in any way responsible or liable for any damages, expenses or losses incurred by you or third parties arising from the use of such information.

### Precaution for Electrostatic

This Product is electrostatic sensitive product, which may be damaged due to electrostatic discharge. Please take proper caution in your manufacturing process and storage so that voltage exceeding the Products maximum rating will not be applied to Products. Please take special care under dry condition (e.g. Grounding of human body / equipment / solder iron, isolation from charged objects, setting of Ionizer, friction prevention and temperature / humidity control).

### Precaution for Storage / Transportation

1. Product performance and soldered connections may deteriorate if the Products are stored in the places where:
  - [a] the Products are exposed to sea winds or corrosive gases, including Cl<sub>2</sub>, H<sub>2</sub>S, NH<sub>3</sub>, SO<sub>2</sub>, and NO<sub>2</sub>
  - [b] the temperature or humidity exceeds those recommended by ROHM
  - [c] the Products are exposed to direct sunshine or condensation
  - [d] the Products are exposed to high Electrostatic
2. Even under ROHM recommended storage condition, solderability of products out of recommended storage time period may be degraded. It is strongly recommended to confirm solderability before using Products of which storage time is exceeding the recommended storage time period.
3. Store / transport cartons in the correct direction, which is indicated on a carton with a symbol. Otherwise bent leads may occur due to excessive stress applied when dropping of a carton.
4. Use Products within the specified time after opening a humidity barrier bag. Baking is required before using Products of which storage time is exceeding the recommended storage time period.

### Precaution for Product Label

A two-dimensional barcode printed on ROHM Products label is for ROHM's internal use only.

### Precaution for Disposition

When disposing Products please dispose them properly using an authorized industry waste company.

### Precaution for Foreign Exchange and Foreign Trade act

Since concerned goods might be fallen under listed items of export control prescribed by Foreign exchange and Foreign trade act, please consult with ROHM in case of export.

### Precaution Regarding Intellectual Property Rights

1. All information and data including but not limited to application example contained in this document is for reference only. ROHM does not warrant that foregoing information or data will not infringe any intellectual property rights or any other rights of any third party regarding such information or data.
2. ROHM shall not have any obligations where the claims, actions or demands arising from the combination of the Products with other articles such as components, circuits, systems or external equipment (including software).
3. No license, expressly or implied, is granted hereby under any intellectual property rights or other rights of ROHM or any third parties with respect to the Products or the information contained in this document. Provided, however, that ROHM will not assert its intellectual property rights or other rights against you or your customers to the extent necessary to manufacture or sell products containing the Products, subject to the terms and conditions herein.

### Other Precaution

1. This document may not be reprinted or reproduced, in whole or in part, without prior written consent of ROHM.
2. The Products may not be disassembled, converted, modified, reproduced or otherwise changed without prior written consent of ROHM.
3. In no event shall you use in any way whatsoever the Products and the related technical information contained in the Products or this document for any military purposes, including but not limited to, the development of mass-destruction weapons.
4. The proper names of companies or products described in this document are trademarks or registered trademarks of ROHM, its affiliated companies or third parties.

**General Precaution**

1. Before you use our Products, you are requested to carefully read this document and fully understand its contents. ROHM shall not be in any way responsible or liable for failure, malfunction or accident arising from the use of any ROHM's Products against warning, caution or note contained in this document.
2. All information contained in this document is current as of the issuing date and subject to change without any prior notice. Before purchasing or using ROHM's Products, please confirm the latest information with a ROHM sales representative.
3. The information contained in this document is provided on an "as is" basis and ROHM does not warrant that all information contained in this document is accurate and/or error-free. ROHM shall not be in any way responsible or liable for any damages, expenses or losses incurred by you or third parties resulting from inaccuracy or errors of or concerning such information.