



SANYO Semiconductors

DATA SHEET

STK621-047A-E

Thick-Film Hybrid IC
— 3-phase Inverter Motor Drive
Inverter Hybrid IC

Overview

This IC is a 3-phase inverter power hybrid IC containing power elements (IGBT and FRD), pre-driver, over-current and excessive temperature protection circuit.

Applications

- 3-phase inverter motor drive

Features

- Integrates power elements (IGBT and FRD), pre-driver, and protective circuit.
- Protective circuits including over-current (bus line), excessive temperature and pre-drive low voltage protection are built in.
- Direct input of CMOS level control signals without an insulating circuit (photo-coupler, etc) is possible.(Hi Active)
- Single power supply drive is possible by using a bootstrap circuit with a built-in IC.
- Temperature monitor is possible by the thermistor inside the IC.
- Built-in simultaneous upper/lower ON prevention circuit to prevent arm shorting through simultaneous ON input for the upper and lower side transistors.
(Dead time is required for preventing shorting due to switching delay.)
- SIP (The single in-line package) of the transfer full mold structure.

■ Any and all SANYO Semiconductor Co.,Ltd. products described or contained herein are, with regard to "standard application", intended for the use as general electronics equipment (home appliances, AV equipment, communication device, office equipment, industrial equipment etc.). The products mentioned herein shall not be intended for use for any "special application" (medical equipment whose purpose is to sustain life, aerospace instrument, nuclear control device, burning appliances, transportation machine, traffic signal system, safety equipment etc.) that shall require extremely high level of reliability and can directly threaten human lives in case of failure or malfunction of the product or may cause harm to human bodies, nor shall they grant any guarantee thereof. If you should intend to use our products for applications outside the standard applications of our customer who is considering such use and/or outside the scope of our intended standard applications, please consult with us prior to the intended use. If there is no consultation or inquiry before the intended use, our customer shall be solely responsible for the use.

■ Specifications of any and all SANYO Semiconductor Co.,Ltd. products described or contained herein stipulate the performance, characteristics, and functions of the described products in the independent state, and are not guarantees of the performance, characteristics, and functions of the described products as mounted in the customer's products or equipment. To verify symptoms and states that cannot be evaluated in an independent device, the customer should always evaluate and test devices mounted in the customer's products or equipment.

STK621-047A-E

Specifications

Absolute Maximum Ratings at $T_c = 25^\circ\text{C}$

Parameter	Symbol	Conditions	Ratings	unit
Supply voltage	V_{CC}	+ - -, surge < 500V *1	450	V
Collector-emitter voltage	V_{CE}	+ - U (V, W) or U (V, W) - -	600	V
Output current	I_O	+, -, U, V, W terminal current	± 20	A
Output peak current	I_{op}	+, -, U, V, W terminal current P.W. = 100 μ s	± 40	A
Pre-driver supply voltage	VD1, 2, 3, 4	VB1 - U, VB2 - V, VB3 - W, $V_{DD} - V_{SS}$ *2	20	V
Input signal voltage	V_{IN}	HIN1, 2, 3, LIN1, 2, 3 terminal	0 to 15	V
FAULT terminal voltage	VFAULT	FAULT terminal	20	V
Maximum loss	P_d	IGBT, Per 1 channel	44.6	W
Junction temperature	T_j	IGBT, FRD junction temperature	150	$^\circ\text{C}$
Storage temperature	T_{stg}		-40 to +125	$^\circ\text{C}$
Operating temperature	T_c	H-IC case temperature	-20 to +100	$^\circ\text{C}$
Tightening torque	MT	A screw part at use M4 type screw *3	1.17	N•m
Withstand voltage	Vis	50Hz sine wave AC 1 minute *4	2000	VRMS

In the case without the instruction, the voltage standard is - terminal = V_{SS} terminal voltage.

*1 Surge voltage developed by the switching operation due to the wiring inductance between the + and - terminals.

*2 VD1 = between VB1-U, VD2 = VB2-V, VD3 = VB3-W, VD4 = $V_{DD} - V_{SS}$, terminal voltage.

*3 Flatness of the heat-sink should be lower than 0.25mm.

*4 The test condition is AC 2500V, 1 second.

Electrical Characteristics at $T_c=25^\circ\text{C}$, $V_D=15\text{V}$

Parameter	Symbol	Conditions	min	typ	max	unit
Power output part						
Collector-to-emitter cut-off current	I_{CE}	$V_{CE} = 600\text{V}$			0.1	mA
Boot-strap diode reverse current	I_R (BD)	V_R (BD) = 600V			0.1	mA
Collector-to-emitter saturation voltage	V_{CE} (sat)	$I_O = 20\text{A}$	Upper side	1.8	2.7	V
			Lower side	2.2	3.1	
Diode forward voltage	V_F	$I_O = -20\text{A}$	Upper side	1.6	2.5	V
			Lower side	2.0	2.9	
Junction-to-substrate thermal resistance	θ_{j-c} (T)	IGBT			2.8	$^\circ\text{C/W}$
	θ_{j-c} (D)	FWD			3.0	$^\circ\text{C/W}$
Control (Pre-driver) part						
Pre-drive power supply consumption electric current	I_D	VD1, 2, 3 = 15V		0.07	0.4	mA
		VD4 = 15V		1.6	4	
Input ON threshold voltage	V_{inH} (on)	HIN1, HIN2, HIN3, LIN1, LIN2,	1.5	2.1	2.5	V
Input OFF threshold voltage	V_{inH} (off)	LIN3- V_{SS} terminal	0.8	1.3	1.5	V
Input threshold voltage hysteresis	V_{inH} (hys)		(0.5)	(0.8)		V
Protection part						
Excessive temperature	TSD	The substrate surface	100		120	$^\circ\text{C}$
Over-current protection electric current	ISD	P.W. = 100 μ s	24.2		30.4	A
Pre-drive low voltage protection	UVLO		10		12	V
FAULT terminal input electric current	IOSD	VFAULT = 0.1V		2		mA
FAULT clearness delay time	FLTCLR	After each protection operation ending	18		80	ms
Board Temperature Mounting resistance	R_t	Resistance between the FAULT and V_{SS} terminals	90	100	110	k Ω
Switching time	t_{ON}	$I_O = 20\text{A}$, Inductive load	0.3	0.6	1.3	μ s
	t_{OFF}			0.9	1.5	
Electric current output signal level	ISO	$I_O = 20\text{A}$	0.38	0.4	0.42	V
Reverse bias safe operating area	RBSOA	$I_O = 40\text{A}$, $V_{CE} = 450\text{V}$	Full Square			
Short circuit safe operating area	SCSOA	$V_{CE} = 200\text{V}$	4			μ s
Allowable offset voltage slew rate	dv/dt	U (V, W) - - terminal	-50		50	V/ns

In the case without the instruction, the voltage standard is - terminal = V_{SS} terminal voltage.

Notes

1. "Input ON threshold voltage" indicates a value to turn on output stage IGBT.
 "Input OFF threshold voltage" indicates a value to turn off output stage IGBT.
 At the time of output ON, set the input signal voltage V_{inH} (max) to 15V.
 At the time of output OFF, set the input signal voltage 0V to V_{inH} (min).
 *1 : "Input threshold voltage hysteresis" indicates a reference value based on the design value of built-in pre-driver IC.
2. When the internal protection circuit operates, there is a Fault signal ON (When the Fault terminal is low level, Fault signal is ON state : output form is open DRAIN) but the Fault signal doesn't latch.
 After protection operation ends, it returns automatically within about 18ms to 80ms and resumes operation beginning condition. So, after Fault signal detection, set OFF (Low) to all input signals at once.
 However, the operation of pre-drive power supply low voltage protection (UVLO: it has a hysteresis about 0.2V) is as follows.
 Upper side → There is no FAULT signal output, but it does a corresponding gate signal OFF.
 Incidentally, it returns to the regular operation when recovering to the normal voltage, but the latch continues among input signal ON (High).
 Lower side → It outputs FAULT signal with gate signal OFF.
 However, it is different from the protection operation of upper side, it automatically resets about 18ms to 80ms later and resumes operation beginning condition when recovering to normal voltage.
 (The protection operation doesn't latch by the input signal.)
3. When assembling the hybrid IC on the heat sink with M4 type screw, tightening torque range is 0.79N•m to 1.17N•m.
 Flatness of the heat-sink should be lower than 0.25mm.
4. The pre-drive low voltage protection is the feature to protect a device when the pre-driver supply voltage declines with the operating malfunction. As for the pre-driver supply voltage decline in case of operation beginning, and so on, we request confirmation in the set.

Package Dimensions

unit:mm (typ)

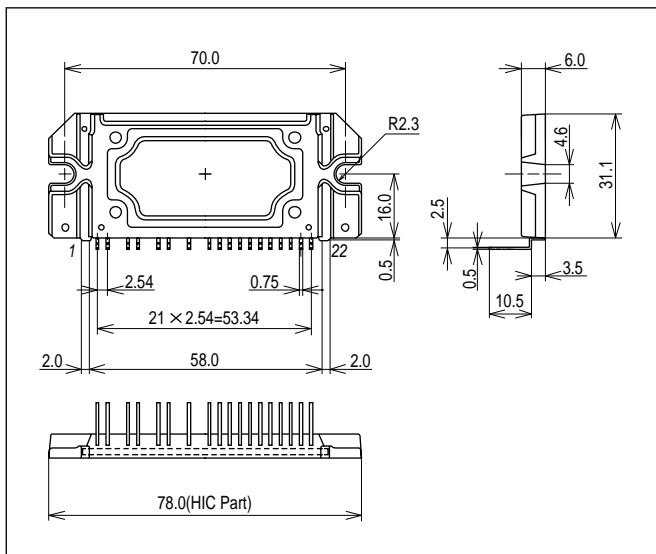

Internal equivalent circuit diagram

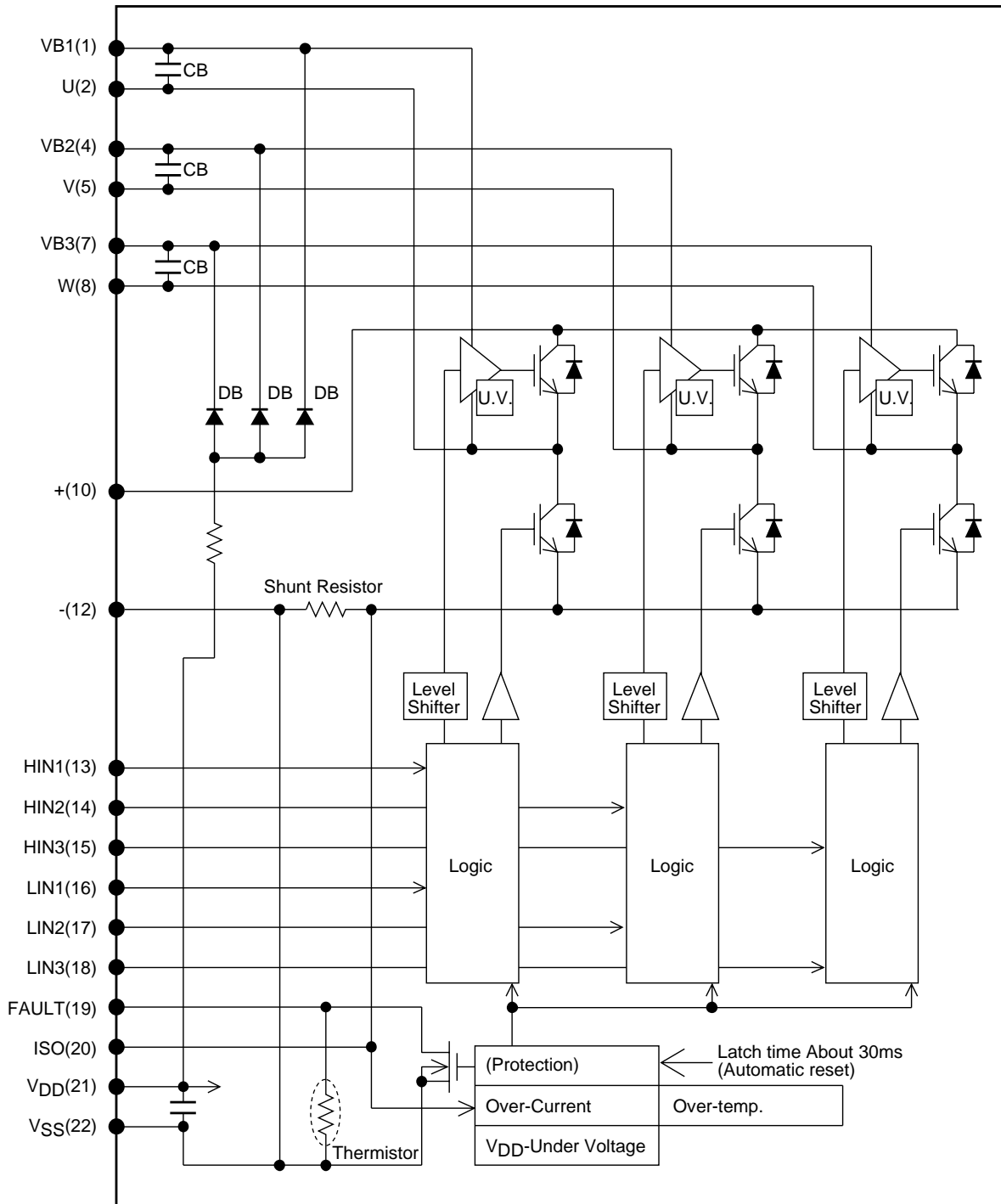

STK621-047A-E

Example of the application circuit

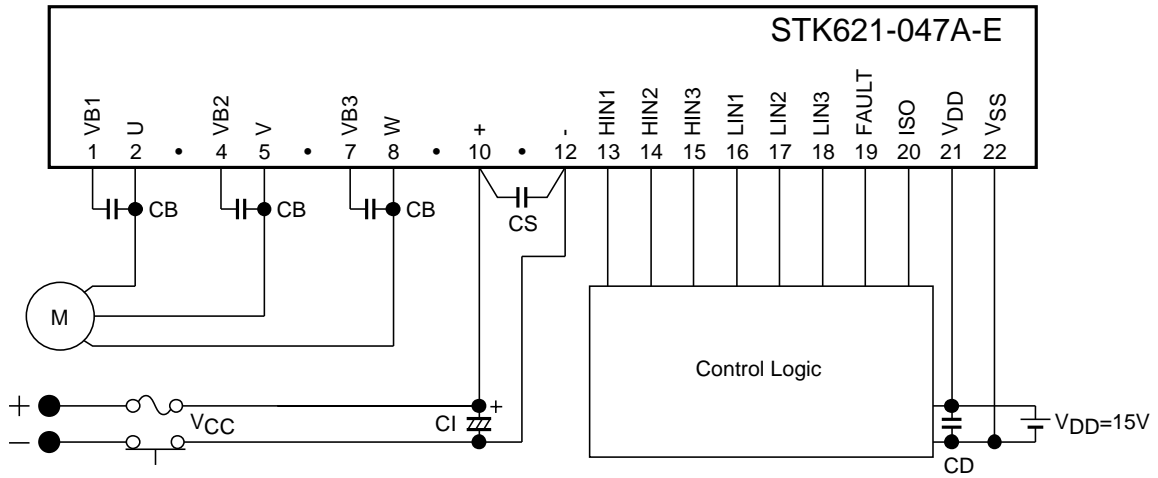

Recommendation Operating Conditions

Parameter	Symbol	Conditions	min	typ	max	unit
Supply voltage	V_{CC}	+ - - terminal	0	280	400	V
Pre-driver supply voltage	VD1, 2, 3	VB1 - U, VB2 - V, VB3 - W	12.5	15	17.5	V
	VD4	$V_{DD} - V_{SS}$ *1	13.5	15	16.5	
ON state input voltage	V_{IN} (ON)	HIN1, HIN2, HIN3,	3.0		5.0	V
OFF state input voltage	V_{IN} (OFF)	LIN1, LIN2, LIN3 Terminal	0		0.3	
PWM frequency	fPWM		1		20	kHz
Dead-time	DT	Upper/lower input signal downtime	2			μ s
Allowable input pulse width	PWIN	ON and OFF	1			μ s
Tightening torque	MT	'M4' type screw	0.79		1.17	N•m

*1 Pre-driver power supply ($VD4 = 15 \pm 1.5V$) must have the capacity of $I_O = 20mA$ (DC), 0.5A (Peak).

Precautions

1. The STK621-047A-E can be driven with a single power supply by placing 1 to 47 μ F bootstrap capacitors (CB) between pins No.1 and No.2, pins No.4 and No.5, and pins No.7 and No.8 for each. In this technique, charge the bootstrap capacitors (CB) by turning the lower side MOSFETs on to output LOW. (Without this technique, each upper side MOSFET needs external power supply independently.) If more than 47 μ F capacitance is used for this technique, connect a resistor (around 20 Ω) between upper side power supply pin (VB1/2/3) and the capacitor in series for each. Since the upper side supply voltage is insufficient due to the control technique, check whether the voltage is adequate or not by testing on the actual application.
2. Switching operation can be affected by the floating inductance of the external wiring connected to + and – pins and some voltage spike occurs. To prevent this, shorten the length of wire from CI to each pin as much as possible to minimize the wiring inductance. In addition, configure a snubber circuit by connecting a capacitor CS2 of about 0.22 to 10 μ F to suppress surge voltage.
3. ISO pin (pin 20) is used to monitor current. Connect 5.6k Ω or more resistance externally. Do not have ISO pin short-circuited to V_{SS} pin. That disables the overcurrent protection.
4. The FAULT/EN pin (pin 19) operates when the signal is low (open drain output). Since a thermistor is built in between FAULT and V_{SS} pins, the substrate temperature can be monitored using the divided voltage with the pull-up resistor RP. For the pull-up resistance, connect 10k Ω or larger capacitor when VP = 5V, 39k Ω or larger capacitor when VP = 15V.
5. Though the STK621-047A-E incorporates 33k Ω (typ) pull-down resistance connected to signal input pins, to further decrease the influence of wiring noise, connect 2.2k Ω to 3.3k Ω pull-down resistors also externally.
6. The overcurrent protection is effective only when the controller operates normally. To assure further safety, set a fuse in V_{CC} line.
7. The HIC may be destroyed if the motor connecting pin (pins 4, 6, or 8) becomes open when the motor is in rotation. Pay attention to the connecting condition of these pins including soldering condition.
8. When the input signal pulse width is shorter than 1 μ s, there are times the output does not respond to the input signal for neither ON nor OFF operation.

* This sample application circuit does not guarantee the design of mass production.

- SANYO Semiconductor Co.,Ltd. assumes no responsibility for equipment failures that result from using products at values that exceed, even momentarily, rated values (such as maximum ratings, operating condition ranges, or other parameters) listed in products specifications of any and all SANYO Semiconductor Co.,Ltd. products described or contained herein.
- SANYO Semiconductor Co.,Ltd. strives to supply high-quality high-reliability products, however, any and all semiconductor products fail or malfunction with some probability. It is possible that these probabilistic failures or malfunction could give rise to accidents or events that could endanger human lives, trouble that could give rise to smoke or fire, or accidents that could cause damage to other property. When designing equipment, adopt safety measures so that these kinds of accidents or events cannot occur. Such measures include but are not limited to protective circuits and error prevention circuits for safe design, redundant design, and structural design.
- In the event that any or all SANYO Semiconductor Co.,Ltd. products described or contained herein are controlled under any of applicable local export control laws and regulations, such products may require the export license from the authorities concerned in accordance with the above law.
- No part of this publication may be reproduced or transmitted in any form or by any means, electronic or mechanical, including photocopying and recording, or any information storage or retrieval system, or otherwise, without the prior written consent of SANYO Semiconductor Co.,Ltd.
- Any and all information described or contained herein are subject to change without notice due to product/technology improvement, etc. When designing equipment, refer to the "Delivery Specification" for the SANYO Semiconductor Co.,Ltd. product that you intend to use.
- Information (including circuit diagrams and circuit parameters) herein is for example only; it is not guaranteed for volume production.
- Upon using the technical information or products described herein, neither warranty nor license shall be granted with regard to intellectual property rights or any other rights of SANYO Semiconductor Co.,Ltd. or any third party. SANYO Semiconductor Co.,Ltd. shall not be liable for any claim or suits with regard to a third party's intellectual property rights which has resulted from the use of the technical information and products mentioned above.

This catalog provides information as of October, 2010. Specifications and information herein are subject to change without notice.