

Apacer In-Vehicle Embedded Modules

Features

- Single Mini PCI Express Socket for All Features
- Equips 2-Channel Individual CAN and 1-Channel J1708 Interfaces
- Vehicle Communication Protocols: OBD-II, J1939 and J1708
- Built-in u-blox NEO-M8 GPS Module (Optionally Support Untethered Dead Reckoning)
- Support GPS, GLONASS and BeiDou system
- Sensor Integrated: 3D Gyroscope and 3D Accelerometer



Introduction

Apacer in-vehicle mini PCI Express card integrate CAN bus module and an extension GPS module.

In one mini PCI Express slot , this module can supply CAN (CAN bus 2.0 a/b, OBDII, J1939, J1708), 3D Gyroscope, 3D Accelerometer and u-blox GPS features. Apacer in-vehicle embedded modules optionally support UDR (Untethered Dead Reckoning GPS) function. UDR can combine inertial sensing data and GNSS signals to supply powerful positioning under poor GPS signal circumstances, such as signal loss in tunnels, driving in parking facilities, urban canyons, and where obstructed GPS signals hinder positioning. Apacer in-vehicle embedded module is the ideal solution for Fleet Management, Public Transportation Monitoring, Law Enforcement, In-Vehicle Digital Signage, Vehicle Data Collection, Vehicle Tracking, and Telematics System.

Specifications

Form Factor	Full Mini PCI Express Mini Card with Extension Board
Host Interface	USB 2.0 via Mini PCI Express Card Socket
CAN Interface Number	CAN for ISO 11898 x 2 Individual Channels J1708 x 1 Channel (Optional)
CAN Protocol	CAN 2.0 A/B, OBD-II (ISO 15765-4), J1939 and J1708 Support Mask and Identifier List Mode
Motion Sensor	3D Gyroscope 3D Accelerometer
GPS Module	u-blox NEO-M8N or M8U Concurrent Reception Up to 3 GNSS System (GPS, GLONASS, BeiDou) Optionally Support Dead Reckoning Optionally Support External Antenna Optionally Support Hot Start Positioning
Identifier filtering	Mask and Identifier List Mode
Driver Support	Microsoft Windows 7 / 10 Linux Kernel 2.6 and 3.13
SDK Support	Microsoft Windows 7 / 10 Linux Kernel 2.6 and 3.13
Operation Temp.	-40° C ~ 85° C (without Hot Start Positioning Function) -20° C ~ 60° C (with Hot Start Positioning Function)
Vibration Test	Pass 7.69G@ 20~2000Hz, compliant with MIL-STD-810G
ESD Protection	8kV Contact, 15kV air
Dimension	50.9 x 30 x 13.2 mm

Dimensions

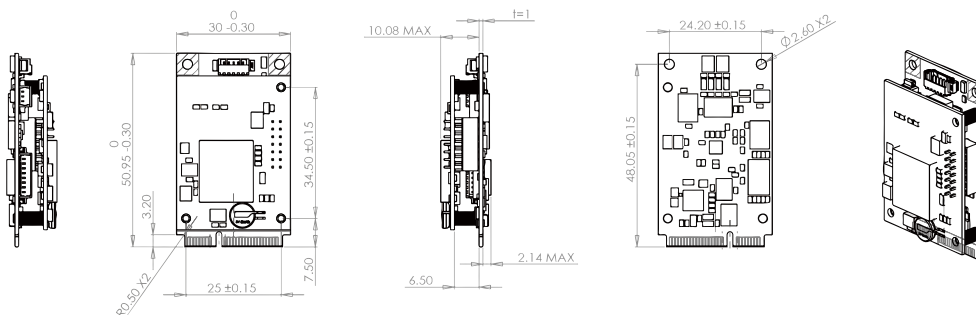

Ordering Information

Part Number	Description
APEFC-G10	2 Channels CAN 2.0 A/B, G-sensor and u-blox NEO-M8N GPS
APEFC-G30	2 Channels CAN 2.0 A/B, OBDII, G-sensor and u-blox NEO-M8N GPS
APEFC-G40	2 Channels CAN 2.0 A/B, OBDII, J1939, G-sensor and u-blox NEO-M8N GPS
APEFC-G50	2 Channels CAN 2.0 A/B, OBDII, J1939, 1 Channel J1708, G-sensor and u-blox NEO-M8N GPS
APEFC-R10	2 Channels CAN 2.0 A/B, G-sensor and u-blox NEO-M8U GPS
APEFC-R30	2 Channels CAN 2.0 A/B, OBDII, G-sensor and u-blox NEO-M8U GPS
APEFC-R40	2 Channels CAN 2.0 A/B, OBDII, J1939, G-sensor and u-blox NEO-M8U GPS
APEFC-R50	2 Channels CAN 2.0 A/B, OBDII, J1939, 1 Channel J1708, G-sensor and u-blox NEO-M8U GPS