

UBA2211

Half-bridge power IC family for CFL lamps

Rev. 3 — 26 August 2011

Product data sheet

1. General description

The UBA2211 family of integrated circuits are a range of high voltage monolithic ICs for driving Compact Fluorescent Lamps (CFL) in half-bridge configurations. The family is designed to provide easy integration of lamp loads across a range of burner power and mains voltages.

2. Features and benefits

2.1 System integration

- Integrated half-bridge power transistors
 - ◆ UBA2211A: 220 V mains; 13.5 Ω ; 0.9 A maximum ignition current
 - ◆ UBA2211B: 220 V mains; 9 Ω ; 1.35 A maximum ignition current
 - ◆ UBA2211C: 220 V mains; 6.6 Ω ; 1.85 A maximum ignition current
- Integrated bootstrap diode
- Integrated high voltage supply

2.2 Burner current

- Adjustable current controlled preheat mode enables the preheat time (t_{ph}) to be set
- RMS current control

2.3 Burner lifetime

- Current controlled preheat with adjustable preheat time and preheat current
- Minimum glow time control to support cold start
- Lamp power independent from mains voltage variations
- Lamp inductor saturation protection during ignition

2.4 Safety

- Saturation Current Protection (SCP)
- OverTemperature Protection (OTP)
- Capacitive Mode Protection (CMP)
- Overpower control
- System shutdown when the burner fails to ignite



2.5 Ease of use

- Adjustable operating frequency for easy fit with various burners
- Each device in the family incorporates the same controller functionality ensuring easy power scaling and roll-out across a complete range of CFLs

3. Applications

- Compact Fluorescent Lamps up to 25 W for indoor and outdoor applications

4. Ordering information

Table 1. Ordering information

Type number	Package		
	Name	Description	Version
UBA2211AP/N1	DIP8	plastic dual in-line package; 8 leads (300 mil)	SOT97-1
UBA2211BP/N1			
UBA2211CP/N1			
UBA2211AT/N1	SO14	plastic small outline package; 14 leads; body width 3.9 mm	SOT108-1
UBA2211BT/N1			
UBA2211CT/N1			

5. Block diagram

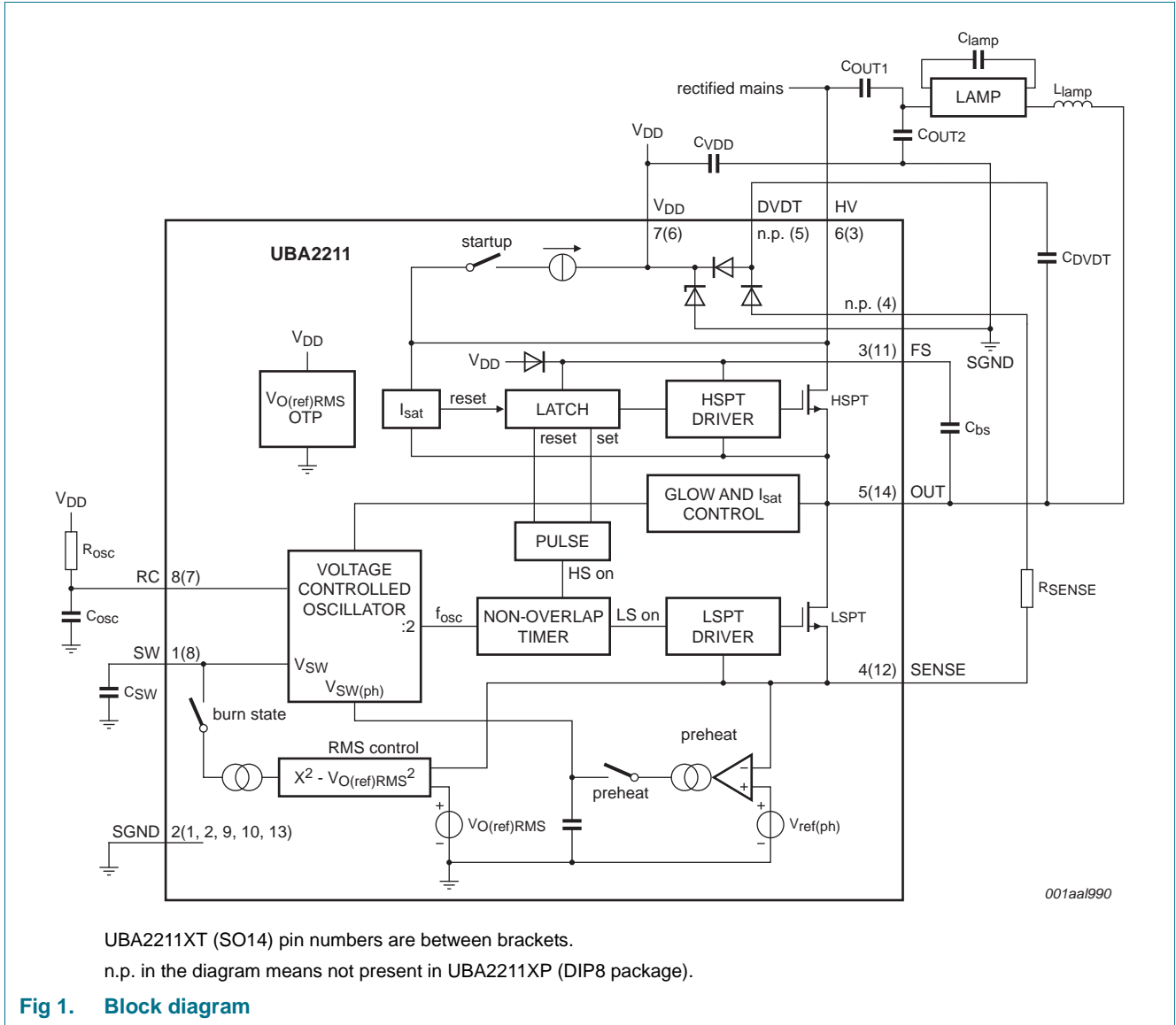

In the SO14 package, the two diodes which are required for the DVDT supply are integrated and connected between pins DVDT and PGND.

Mount these diodes externally when using the DIP8 packaged devices because they are not bonded out.

6. Pinning information

6.1 Pinning

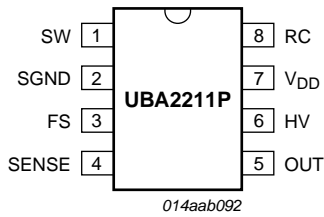

Fig 2. Pin configuration for UBA2211XP (SOT97-1)

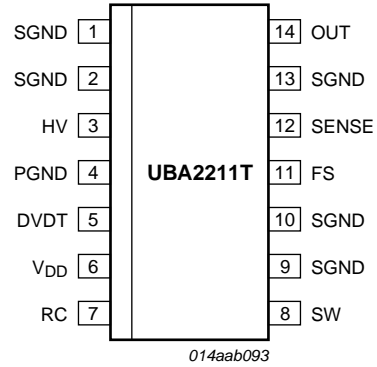

Fig 3. Pin configuration for UBA2211XT (SOT108-1)

6.2 Pin description

Table 2. Pin description

Symbol	Pin		Description
	UBA2211XP	UBA2211XT	
SW	1	8	sweep timing and VCO input
SGND	2	1, 2, 9, 10, 13	signal ground
FS	3	11	high-side floating supply output
SENSE	4	12	voltage sense for preheat and RMS control
OUT	5	14	half-bridge output
HV	6	3	high-voltage supply
V _{DD}	7	6	internal low-voltage supply output
RC	8	7	internal oscillator input
DVDT	n.p.	5	DVDT supply input
PGND	n.p.	4	DVDT supply ground

7. Functional description

7.1 Supply voltage

The UBA2211 family is powered using a start-up current source and a DVDT supply. When the voltage on pin HV increases, the V_{DD} capacitor (C_{VDD}) is charged using the internal Junction gate Field-Effect Transistor (JFET) current source. The voltage on pin V_{DD} rises until V_{DD} equals $V_{DD(start)}$. The start-up current source is then disabled. The half-bridge starts switching causing the charge pump to generate the required V_{DD} supply.

The amount of current flowing towards V_{DD} equals $V_{HV} \times C_{DVDT} \times f$ where f represents the momentary frequency. The charge pump consists of an external half-bridge capacitor (C_{DVDT}). The SO14 package contains two internal diodes with an internal Zener diode. Mount these diodes externally with the DIP8 packaged devices. The Zener diode ensures the V_{DD} voltage cannot rise above the maximum V_{DD} rating.

The DVDT supply has its own ground pin (PGND) to prevent large peak currents from flowing through the external small signal ground pin (SGND).

The start-up current source is enabled when the voltage on pin V_{DD} is below the $V_{DD(stop)}$ level.

7.2 Start-up state

When the supply voltage on pin V_{DD} increases, the IC enters the start-up state. In the start-up state the High-Side Power Transistor (HSPT) is switched off and the Low-Side Power Transistor (LSPT) is switched on. The circuit is reset and the capacitors on the bootstrap pin FS (C_{bs}) and the low-voltage supply pin V_{DD} (C_{VDD}) are charged. Pins RC and SW are switched to ground.

When pin V_{DD} is above $V_{DD(start)}$, the start-up state is exited and the preheat state is entered. If the voltage on pin V_{DD} falls below $V_{DD(stop)}$, the system returns to the start-up state.

Remark: If OTP is active, the IC remains in the start-up state indefinitely. The V_{DD} voltage slowly oscillates between $V_{DD} = V_{DD(stop)}$ and $V_{DD} = V_{DD(start)}$.

7.3 Reset

A DC reset circuit is incorporated in the high-side driver. The high-side transistor is switched off when the voltage on pin FS is below the high-side lockout voltage.

7.4 Oscillation control

The oscillation frequency is based on the 555-timer function. A self oscillating circuit is created comprising the external components: resistors R_{osc} , R_{sense} and capacitor C_{osc} . R_{osc} and C_{osc} determine the nominal oscillating frequency.

An internal divider $0.5 \times f_{osc(int)}$ is used to generate the accurate 50 % duty cycle. The divider sets the bridge frequency at half the oscillator frequency.

The input on pin SW generates the V_{SW} signal and it is used to determine the frequency in all states except preheat. Signal $V_{SW(ph)}$ is an internally generated signal used to determine the frequency during the preheat state.

The output voltage of the bridge changes with the falling edge of the signal on pin RC. The nominal half-bridge frequency is shown in [Equation 1](#):

$$f_{osc(nom)} = \frac{I}{k_{osc} \times R_{osc} \times C_{osc}} \tag{1}$$

The maximum frequency is $2.5 \times f_{osc(nom)}$ and is set at V_{SW} . An overview of the oscillator, internal LSPT and HSPT drive signals and the output is shown in [Figure 4](#).

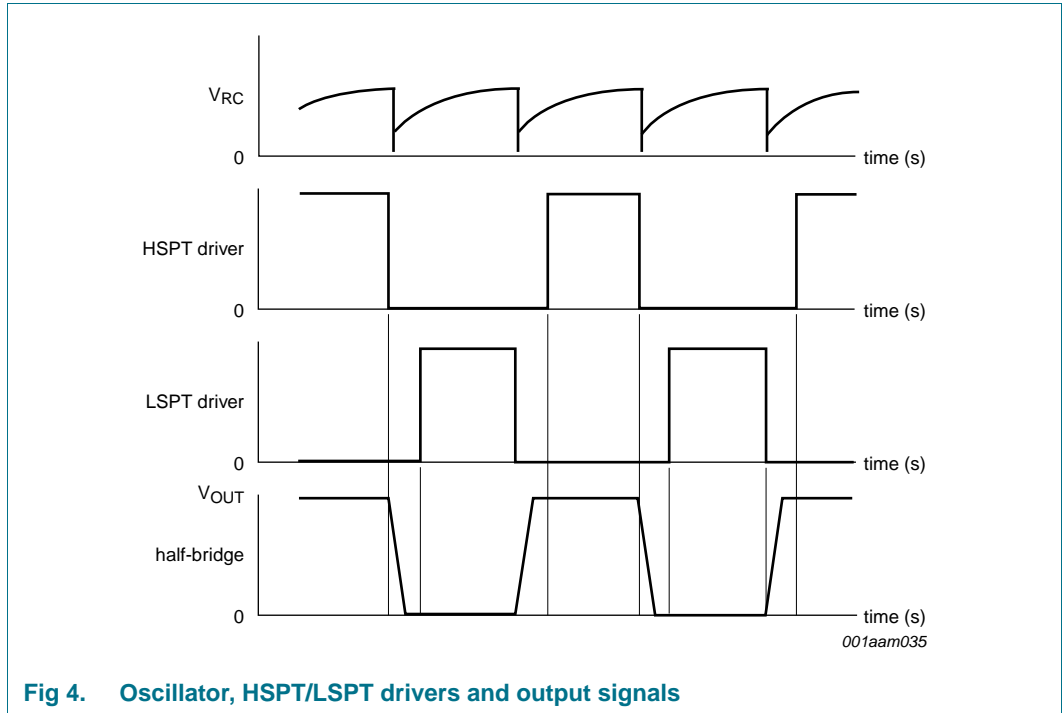

Fig 4. Oscillator, HSPT/LSPT drivers and output signals

7.5 Preheat state

As described in [Section 7.2](#), the IC enters the preheat state when the voltage on pin V_{DD} is above $V_{DD(start)}$ and OTP is not active. The sweep current (I_{SW}) charges the capacitor on pin SW (C_{SW}). The preheat Operational Transconductance Amplifier (OTA) is enabled and the half-bridge circuit starts oscillating.

The preheat current is monitored using the external R_{SENSE} resistor. The OTA controls the frequency using output voltage $V_{SW(ph)}$ so that the peak voltage across R_{SENSE} equals the internal reference voltage ($V_{ref(ph)}$). The peak voltage is the voltage at the end of the LSPT conduction time. The preheat peak current through the lamp filament is calculated as shown in [Equation 2](#):

$$I_{ph(peak)} = \frac{V_{ref(ph)}}{R_{SENSE}} \tag{2}$$

The value of the external capacitor (C_{SW}) sets the preheat time. Typically, the external capacitor is calculated as shown in [Equation 3](#). The preheat state ends when the falling C_{SW} voltage equals $V_{SW(ph)}$; see [Figure 4](#).

$$C_{sw} = \frac{t_{ph}}{1.5 \text{ s} \times 100 \text{ nF}} \tag{3}$$

If during the preheat time, capacitive mode is sensed and the internal V_{SW} HIGH node is discharged. The frequency sweep restarts at f_{max} which is equal to $2.5 \times f_{min}$.

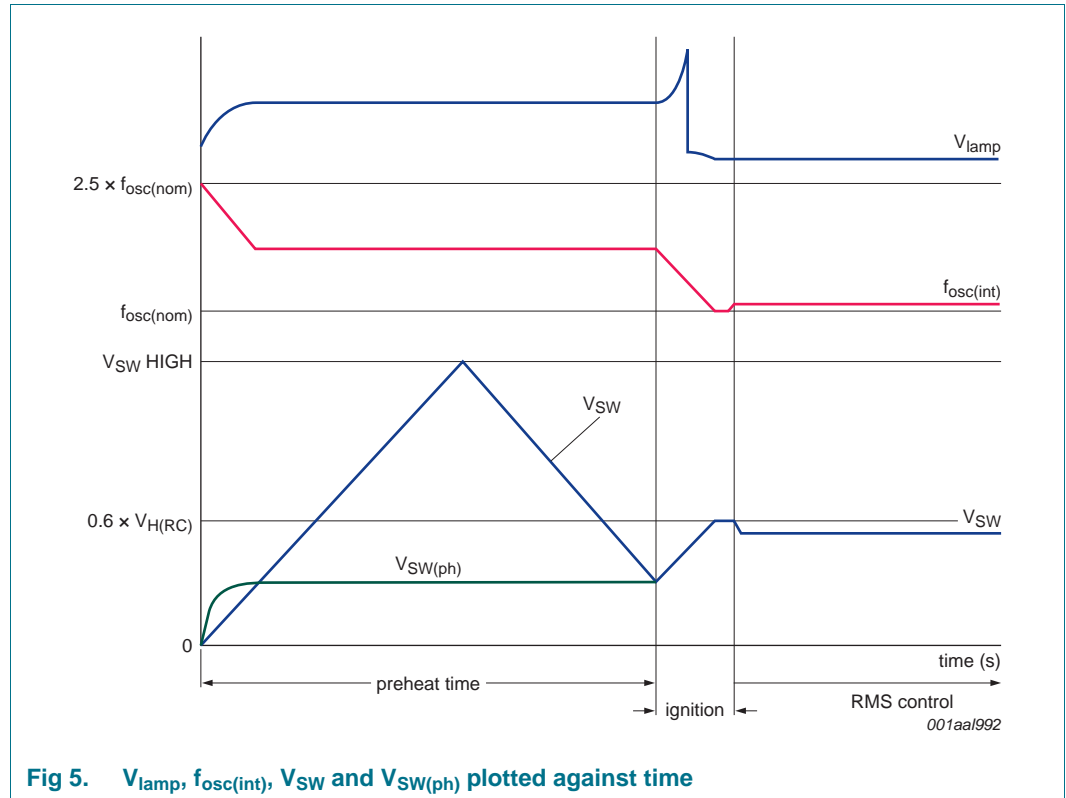

7.6 Ignition state

The ignition state is entered after the preheat state has finished. The current I_{SW} charges the capacitor on pin SW (C_{SW}) up to $0.6 \times V_{H(RC)}$ which corresponds to the frequency $f_{osc(nom)}$.

During this frequency sweep, the resonance frequency is reached resulting in the ignition of the lamp (see Figure 4). The combination of lamp inductor (L_{lamp}) and lamp capacitor (C_{lamp}) set the resonance frequency. The ignition state ends when the voltage on pin SW (V_{SW}) reaches $0.6 \times V_{H(RC)}$.

7.7 Steady state

In the steady state, the RMS current control is active. This control sets the frequency so that the RMS voltage across the sense resistor (R_{SENSE}) is equal to $V_{O(ref)RMS}$. This ensures the current through the power switches and through the lamp is constant. This results in constant IC dissipation and temperature at a fixed ambient temperature.

During one oscillator clock cycle, the voltage on pin SENSE (V_{SENSE}) is squared and converted into a positive current. This discharge current is added to the capacitor C_{SW} .

During the other oscillator clock cycle, the input of the squarer is connected to the internal reference voltage $V_{O(ref)RMS}$. This voltage is squared and converted into a negative current. This charge current is also added to capacitor C_{SW} . When both currents are equal, then [Equation 4](#) is true:

$$\frac{I}{T_{osc}} \times \int_0^{T_{osc}} V_{SENSE^2(t)} DT = \frac{I}{T_{osc}} \times \int_0^{T_{osc}} V_{O(ref)RMS^2} DT \quad (4)$$

Where T_{OSC} equals the operating frequency $f_{osc} / 1$.

Taking the square root of both sides results in [Equation 5](#):

$$\sqrt{\frac{I}{T_{osc}} \times \int_0^{T_{osc}} V_{SENSE^2(t)} DT} = \sqrt{\frac{I}{T_{osc}} \times \int_0^{T_{osc}} V_{O(ref)RMS^2} DT} \quad (5)$$

or

$$RMS V_{SENSE} = V_{O(ref)RMS} = R_{SENSE} \times I_{LSPT} \quad (6)$$

A constant current flows through the power switches and the lamp which is defined by the internal reference voltage ($V_{O(ref)RMS}$) and the external R_{SENSE} resistor.

The R_{SENSE} resistor sets both the preheat current and the RMS half-bridge current. The ratio between them is fixed. However by adding a resistor in parallel to C_{SW} (see [Figure 7](#)) this ratio can be adjusted. The ratio adjustment is described in more detail in [UM10418](#), the *UBA2211 user manual*.

7.8 Non-overlap time

The non-overlap time is defined as the time when both MOSFETs are not conducting. The non-overlap time is fixed internally and is fixed at the t_{no} value (see [Table 5](#)).

7.9 OverTemperature Protection (OTP)

OTP is active in all states. When the die temperature reaches the OTP activation threshold ($T_{th(otp)}$), the oscillator is stopped and the power switches (LSPT/HSPT) are set to the start-up state. When the oscillator is stopped, the DVDT supply no longer generates the supply current I_{DVDT} . Voltage V_{DD} gradually decreases and the start-up state is entered as described in [Section 7.2 on page 5](#). OTP is reset when the temperature $< T_{th(rel)otp}$.

7.10 Minimum glow time control

If the preheat time is set too short or omitted, the lamp electrodes do not have the correct temperature in the ignition state. This results in instant light but also in a reduced switching lifetime because when the electrode temperature is too low electrode sputtering and damage occur. The minimum glow time control minimizes electrode damage by ensuring maximum power use during the glow phase to heat the electrodes as quickly as possible (see [Figure 6](#)).

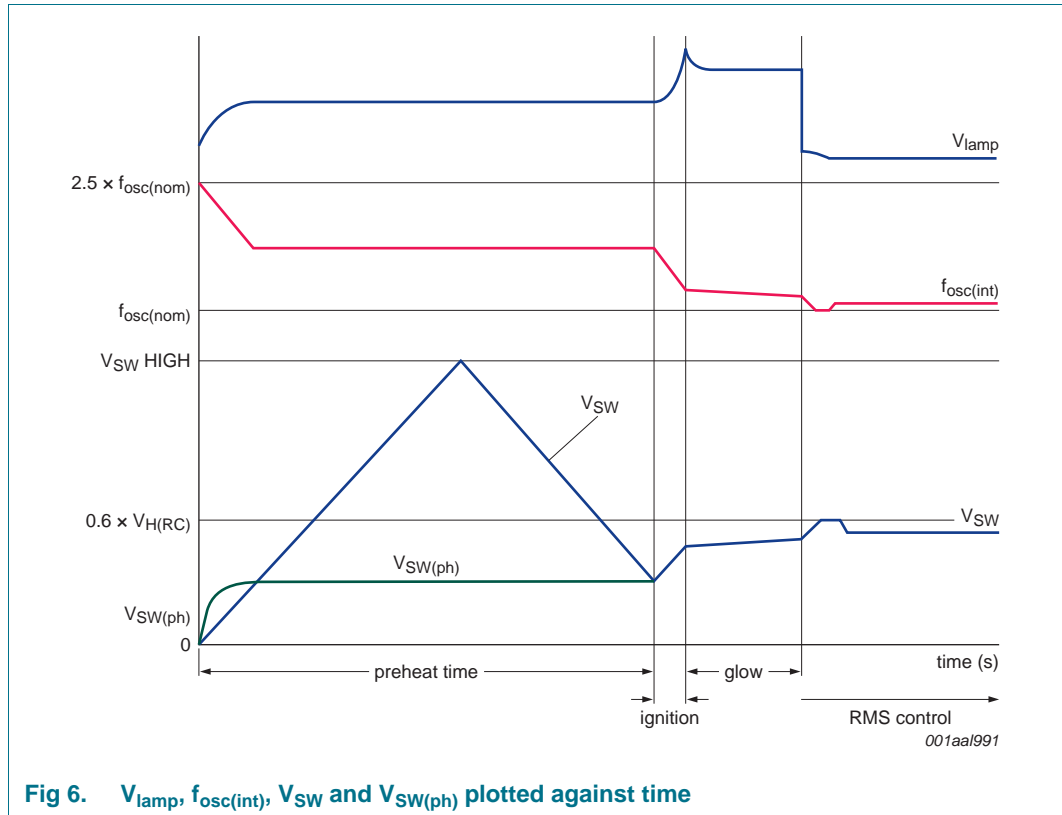

Fig 6. V_{lamp} , $f_{osc(int)}$, V_{SW} and $V_{SW(ph)}$ plotted against time

Remark: The glow time control is active as t_{ph} is too short to preheat the electrodes.

7.11 Saturation Current Protection (SCP)

A critical parameter in the design of the lamp inductor is its saturation current. When the momentary inductor exceeds its saturation current, the inductance drops significantly. If the inductance drops significantly, the inductor current and the current flowing through the high-side and low-side power switches increases rapidly. This increase can cause the current to exceed the half-bridge power transistors maximum ratings.

Saturation of the lamp inductor is likely to occur in cost-effective and miniaturized CFLs. The UBA2211 family internally monitors the power transistor current. When this current exceeds the momentary rating of the internal power transistors, the conduction time is reduced and the frequency is slowly increased (by discharging C_{SW}). This action causes the system to balance at the edge of the current rating of the power switches.

7.12 Capacitive Mode Protection (CMP)

When capacitive mode is detected, capacitor C_{SW} is discharged causing the frequency to increase. The system sets itself to the operating point where capacitive mode switching is minimized. CMP is active during the ignition state and in the steady state.

If capacitive mode is sensed during the preheat time, the oscillator restarts at f_{max} (which is $2.5 \times f_{min}$). CMP could be triggered by an end of lamp life condition when a lamp electrode is broken.

8. Limiting values

Table 3. Limiting values

In accordance with the Absolute Maximum Rating System (IEC 60134).

Symbol	Parameter	Conditions	Min	Max	Unit
V _{HV}	voltage on pin HV	operating	-	373	V
		mains transients: 10 minutes maximum over lifetime	-	550	V
V _{FS}	voltage on pin FS	with respect to pin OUT	0	14	V
V _{DD}	supply voltage	DC supply	0	15	V
V _{SENSE}	voltage on pin SENSE		-5	+5	V
V _{RC}	voltage on pin RC	I _{RC} < 1 mA	0	V _{DD}	V
V _{SW}	voltage on pin SW	I _{SW} < 1 mA	0	V _{DD}	V
I _{OUT}	current on pin OUT	T _j < 125 °C	[1]		
		UBA2211AX	-0.9	+0.9	A
		UBA2211BX	-1.35	+1.35	A
		UBA2211CX	-1.65	+1.65	A
I _{DVDT}	current on pin DVDT	T _j < 125 °C	-0.9	+0.9	A
SR	slew rate	repetitive output on pin OUT	-4	+4	V/ns
T _j	junction temperature		-40	+150	°C
T _{stg}	storage temperature		-55	+150	°C
V _{ESD}	electrostatic discharge voltage	HBM:	[2]		
		pins HV, FS, OUT	-	1000	V
		pins SW, RC, VDD, DVDT	-	2500	V
		MM:	[3]		
		all pins	-	250	V
		CDM:	[3]		
	all pins	-	500	V	

[1] X where the last letter is P or T.

[2] In accordance with the Human Body Model (HBM): equivalent to discharging a 100 pF capacitor through a 1.5 kΩ series resistor.

[3] In accordance with the Machine Model (MM): equivalent to discharging a 200 pF capacitor through a 1.5 kΩ series resistor and a 0.75 μH inductor.

9. Thermal characteristics

Table 4. Thermal characteristics

Symbol	Parameter	Conditions	Typ	Unit
R _{th(j-a)}	thermal resistance from junction to ambient	in free air	[1] 95	K/W
R _{th(j-c)}	thermal resistance from junction to case	in free air	[1] 16	K/W

[1] In accordance with IEC 60747-1

10. Characteristics

Table 5. Characteristics

$T_j = 25\text{ °C}$; all voltages are measured with respect to SGND; positive currents flow into the IC.

Symbol	Parameter	Conditions	Min	Typ	Max	Unit
Low-voltage supply						
Start-up state						
I_{HV}	current on pin HV	$V_{HV} = 100\text{ V}$	-	0.85	-	mA
$V_{DD(start)}$	start supply voltage	oscillation start	10.7	11.7	12.7	V
$V_{DD(stop)}$	stop supply voltage	oscillation stop	8	8.5	9	V
$V_{DD(hys)}$	hysteresis of supply voltage	start – stop	3	3.5	4	V
$V_{DD(reg)}$	regulation supply voltage		-	13.8	-	V
I_{sink}	sink current	capability of VDD regulator	6	-	-	mA
Output stage						
R_{on}	on-state resistance	high-side transistor: [1]				
		UBA2211AX; $V_{HV} = 310\text{ V}$; $I_D = 100\text{ mA}$	-	13.5	-	Ω
		UBA2211BX; $V_{HV} = 310\text{ V}$; $I_D = 100\text{ mA}$	-	9.3	-	Ω
		UBA2211CX; $V_{HV} = 310\text{ V}$; $I_D = 100\text{ mA}$	-	6.6	-	Ω
		low-side transistor: [1]				
		UBA2211AX; $I_D = 100\text{ mA}$	-	13.5	-	Ω
		UBA2211BX; $I_D = 100\text{ mA}$	-	8.2	-	Ω
		UBA2211CX; $I_D = 100\text{ mA}$	-	6.6	-	Ω
$R_{on(150)}/R_{on(25)}$	on-state resistance ratio (150 °C to 25 °C)		-	1.4	-	
V_F	forward voltage	HS; $I_F = 200\text{ mA}$	-	-	2	V
		LS; $I_F = 200\text{ mA}$	-	-	2	V
		bootstrap diode; $I_F = 1\text{ mA}$	0.7	1	1.3	V
t_{no}	non-overlap time		1.05	1.35	1.65	μs
V_{FS}	voltage on pin FS	UnderVoltage LockOut with respect to pin OUT	3.6	4.2	4.8	V
I_{FS}	current on pin FS	$V_{HV} = 310\text{ V}$; $V_{FS} = 12\text{ V}$	10	14	18	μA
I_{sat}	saturation current	high-side transistor: [1]				
		UBA2211AX; $V_{DS} = 30\text{ V}$; $T_j \leq 125\text{ °C}$; $V_{HV} = 310\text{ V}$	0.90	-	-	A
		UBA2211BX; $V_{DS} = 30\text{ V}$; $T_j \leq 125\text{ °C}$; $V_{HV} = 310\text{ V}$	1.35	-	-	A
		UBA2211CX; $V_{DS} = 30\text{ V}$; $T_j \leq 125\text{ °C}$; $V_{HV} = 310\text{ V}$	1.85	-	-	A
		low-side transistor: [1]				
		UBA2211AX; $V_{DS} = 30\text{ V}$; $T_j \leq 125\text{ °C}$	0.90	-	-	A
		UBA2211BX; $V_{DS} = 30\text{ V}$; $T_j \leq 125\text{ °C}$	1.35	-	-	A
		UBA2211CX; $V_{DS} = 30\text{ V}$; $T_j \leq 125\text{ °C}$	1.85	-	-	A

Table 5. Characteristics ...continued $T_j = 25\text{ }^\circ\text{C}$; all voltages are measured with respect to SGND; positive currents flow into the IC.

Symbol	Parameter	Conditions	Min	Typ	Max	Unit
Internal oscillator						
$f_{\text{osc(int)}}$	internal oscillator frequency	$V_{\text{SW}} = V_{\text{DD}}$; steady state	-	-	60	kHz
$f_{\text{osc(nom)}}$	nominal oscillator frequency	$R_{\text{osc}} = 100\text{ k}\Omega$; $C_{\text{osc}} = 220\text{ pF}$; $V_{\text{SW}} = V_{\text{DD}}$	40.05	41.32	42.68	kHz
$f_{\text{osc(max)}}$	maximum oscillator frequency	$R_{\text{osc}} = 100\text{ k}\Omega$; $C_{\text{osc}} = 220\text{ pF}$; $V_{\text{SW}} = 0\text{ V}$	-	104	-	kHz
$\Delta f_{\text{osc(nom)}}/\Delta T$	nominal oscillator frequency variation with temperature	$R_{\text{osc}} = 100\text{ k}\Omega$; $C_{\text{osc}} = 220\text{ pF}$; $\Delta T = -20\text{ to }+150\text{ }^\circ\text{C}$	-	2	-	%
k_{H}	high-level trip point factor		0.382	0.395	0.408	
k_{L}	low-level trip point factor		0.030	0.033	0.036	
$V_{\text{H(RC)}}$	HIGH-level voltage on pin RC	trip point; $V_{\text{H(RC)}} = k_{\text{H}} \times V_{\text{DD}}$	4.58	4.94	5.29	V
$V_{\text{L(RC)}}$	LOW-level voltage on pin RC	trip point; $V_{\text{L(RC)}} = k_{\text{L}} \times V_{\text{DD}}$	0.367	0.413	0.458	V
K_{osc}	oscillator constant	$R_{\text{osc}} = 100\text{ k}\Omega$; $C_{\text{osc}} = 220\text{ pF}$	1.065	1.1	1.135	
Preheat function						
$V_{\text{ref(ph)}}$	preheat reference voltage		-	620	-	mV
t_{ph}	preheat time	$C_{\text{SW}} = 47\text{ nF}$	-	0.55	-	s
RMS current control function						
$V_{\text{O(ref)RMS}}$	RMS reference output voltage		262	285	308	mV
OTP function						
$T_{\text{th(act)otp}}$	overtemperature protection activation threshold temperature		155	175	-	$^\circ\text{C}$
$T_{\text{th(rel)otp}}$	overtemperature protection release threshold temperature		-	100	-	$^\circ\text{C}$

[1] X where the last letter is P or T.

11. Application information

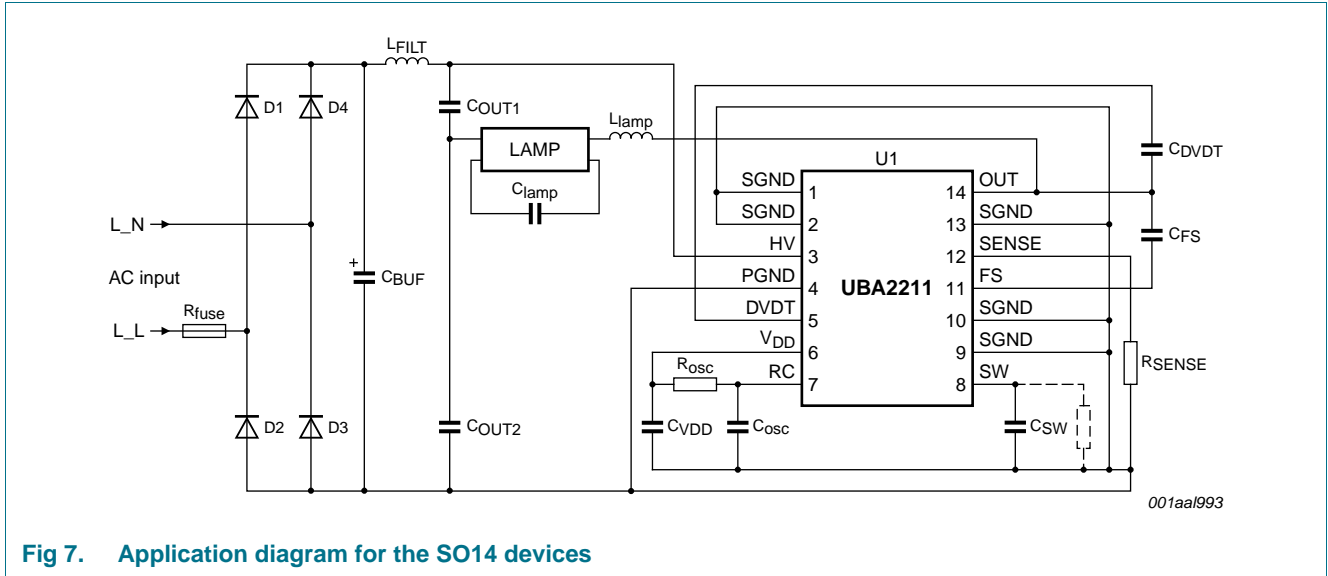

Fig 7. Application diagram for the SO14 devices

The components used in [Figure 7](#) are illustrated in [Table 6](#).

Table 6. SO14 device bill of materials

Number	Reference	Alias	Typical value	Quantity
1	R _{fuse}		10 Ω; 1 W	1
2	D1, D2, D4, D5		M7	4
3	C _{BUF}	C1	2.7 μF; 400 V; 105 °C; 10*16	1
4	C _{FS}	C5	10 nF; 50 V; 0805	1
5	C _{SW} , C _{VDD}	C6	100 nF; 50 V; 0805	2
6	C _{DVDT}	C9	220 pF; 500 V	1
7	C _{osc}	C7	220 pF; 50 V; 0805	1
9	C0, C _{OUT1} , C _{OUT2}	C0, C2, C3	100 nF; 400 V; CL21	3
10	C _{lamp}	C4	2.2 nF; 1 kV; CBB28	1
11	L _{FILT}	L1	3 mH; LGB	1
12	L _{lamp}	L2	3 mH; EE13; PC40	1
13	R _{osc}	R1	100 kΩ; 1 %; 0805	1
14	R _{SENSE}	R2	1.8 Ω; 1 W; 1 %	1
15	PCB		UBA2211-1; UBA2211-8	2
16	IC		UBA2211B	1
17	Burner		3U-12 W; 2700k	1

Remark: The customized component values depend on the burner characteristics. An on-line tool is available to calculate the required components values. This on-line tool can be found on the product information page of the UBA2211.

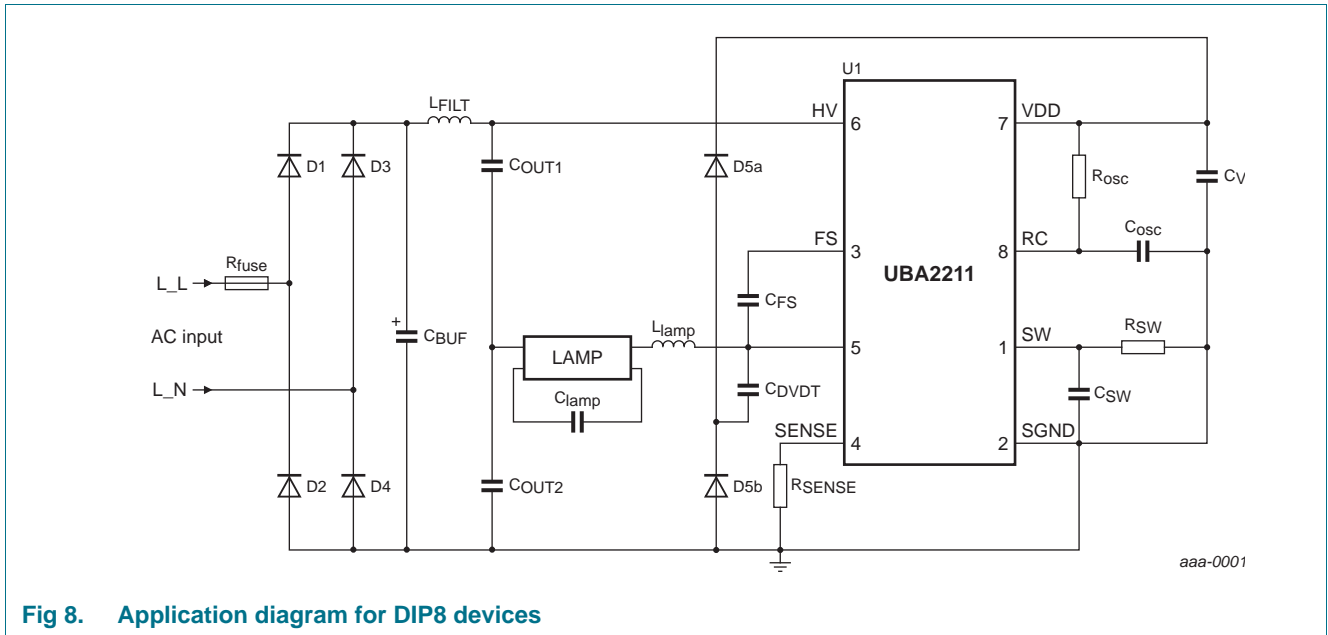

Fig 8. Application diagram for DIP8 devices

The components used in [Figure 8](#) are illustrated in [Table 7](#).

Table 7. DIP8 device bill of materials

Number	Reference	Alias	Typical value	Quantity
1	R _{fuse}	-	22 Ω; 1 W	1
2	D1, D2, D4, D5	-	M7	4
2	D5a, D5b	-	1N4148	2
3	C _{BUF}	C1	2.7 μF; 400 V; 105 °C; 10*16	1
4	C _{FS}	C5	10 nF; 50 V; 0805	1
5	C _{SW} , C _{VDD}	C6	100 nF; 50 V; 0805	2
6	C _{DVDT}	C9	220 pF; 630 V	1
7	C _{osc}	C7	220 pF; 50 V; 0805	1
9	C _{OUT1} , C _{OUT2}	C0, C2, C3	100 nF; 400 V; CL21	3
10	C _{lamp}	C4	2.2 nF; 1 kV; CBB28	1
11	L _{FILT}	L1	3 mH; LGB	1
12	L _{lamp}	L2	3 mH; EE13; PC40	1
13	R _{osc}	R1	100 kΩ; 1 %; 0805	1
14	R _{SENSE}	R2	1.8 Ω; 1 W; 1 %	1
15	R _{SW}	R _{SW}	not mounted	2
16	IC	-	UBA2211BP	1
17	Burner	-	3U-12 W; 2700k	1

Remark: The customized component values depend on the burner characteristics. An on-line tool is available to calculate the required components values. This on-line tool can be found on the product information page of the UBA2211.

12. Package outline

DIP8: plastic dual in-line package; 8 leads (300 mil)

SOT97-1

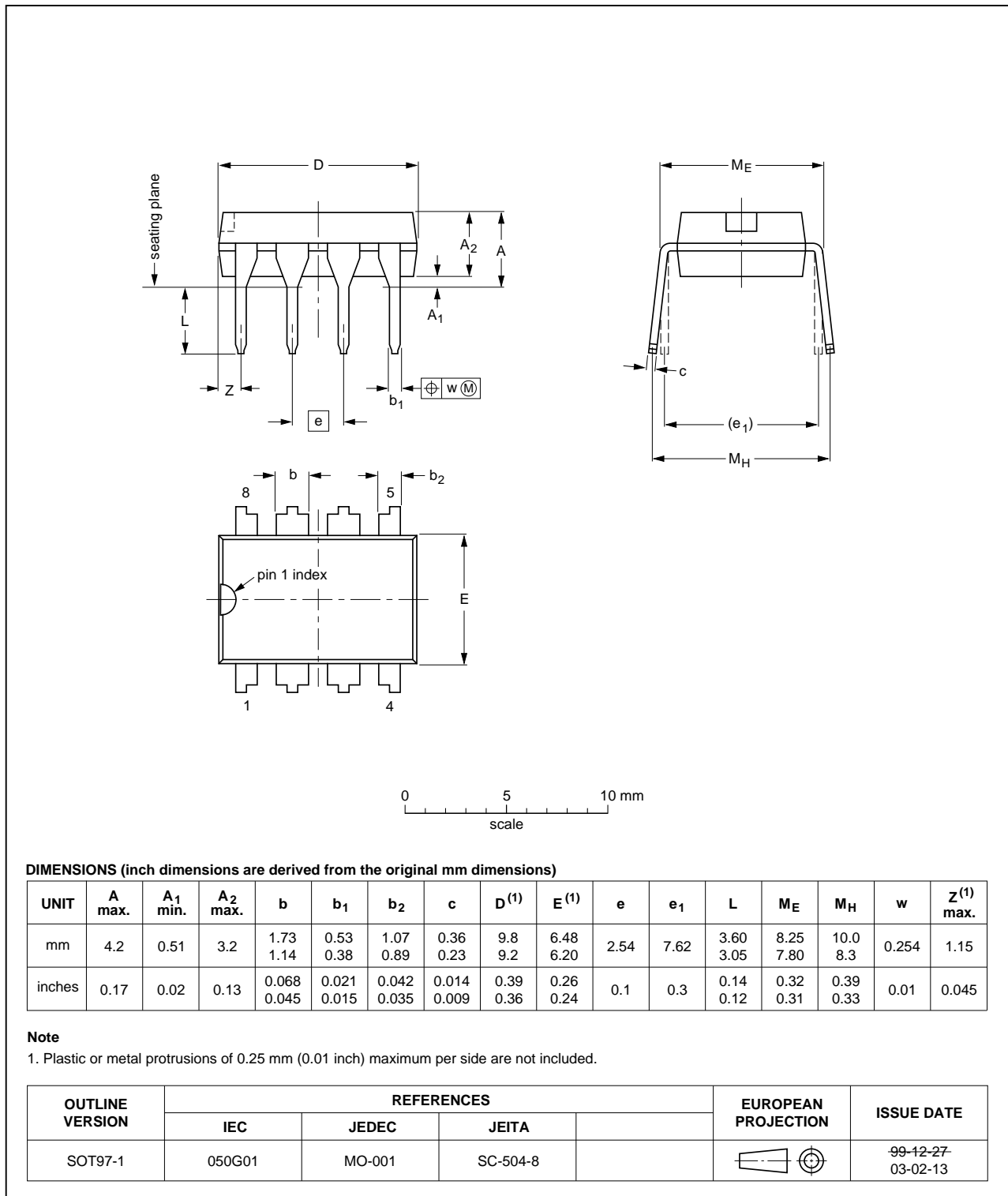

Fig 9. Package outline SOT97-1 (DIP8)

SO14: plastic small outline package; 14 leads; body width 3.9 mm

SOT108-1

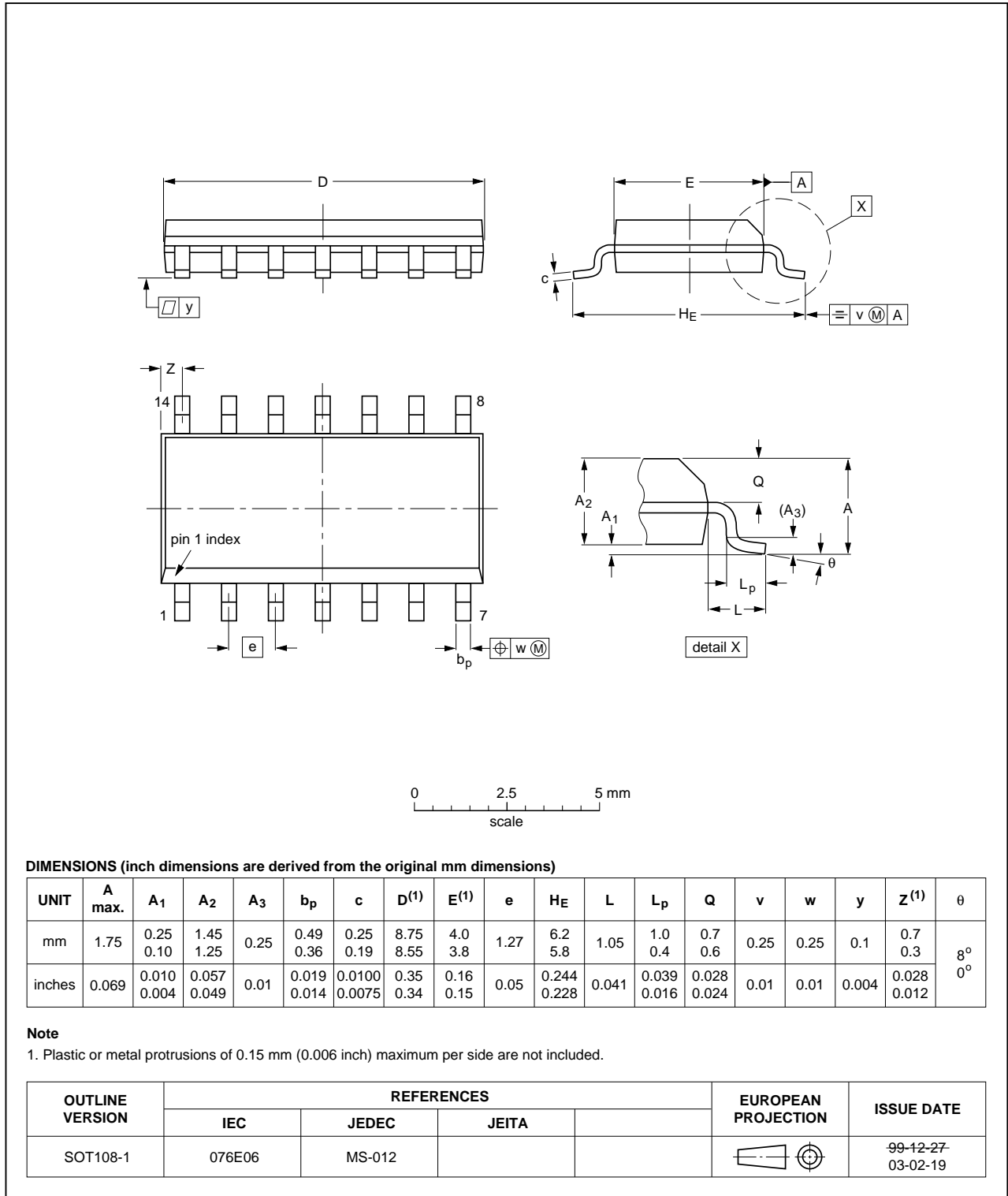

Fig 10. Package outline SOT108-1 (SO14)

13. Revision history

Table 8. Revision history

Document ID	Release date	Data sheet status	Change notice	Supersedes
UBA2211 v.3	20110826	Product data sheet	-	UBA2211 v.2.1
Modifications:		<ul style="list-style-type: none">• Data sheet status changed from preliminary to product.• Figure 8 “Application diagram for DIP8 devices” and Table 7 “DIP8 device bill of materials” added.• Minor text and graphics changes.		
UBA2211 v.2.1	20110307	Preliminary data sheet	-	UBA2211 v.2
UBA2211 v.2	20110103	Objective data sheet	-	UBA2211 v.1
UBA2211 v.1	20100628	Objective data sheet	-	-

14. Legal information

14.1 Data sheet status

Document status ^{[1][2]}	Product status ^[3]	Definition
Objective [short] data sheet	Development	This document contains data from the objective specification for product development.
Preliminary [short] data sheet	Qualification	This document contains data from the preliminary specification.
Product [short] data sheet	Production	This document contains the product specification.

[1] Please consult the most recently issued document before initiating or completing a design.

[2] The term 'short data sheet' is explained in section "Definitions".

[3] The product status of device(s) described in this document may have changed since this document was published and may differ in case of multiple devices. The latest product status information is available on the Internet at URL <http://www.nxp.com>.

14.2 Definitions

Draft — The document is a draft version only. The content is still under internal review and subject to formal approval, which may result in modifications or additions. NXP Semiconductors does not give any representations or warranties as to the accuracy or completeness of information included herein and shall have no liability for the consequences of use of such information.

Short data sheet — A short data sheet is an extract from a full data sheet with the same product type number(s) and title. A short data sheet is intended for quick reference only and should not be relied upon to contain detailed and full information. For detailed and full information see the relevant full data sheet, which is available on request via the local NXP Semiconductors sales office. In case of any inconsistency or conflict with the short data sheet, the full data sheet shall prevail.

Product specification — The information and data provided in a Product data sheet shall define the specification of the product as agreed between NXP Semiconductors and its customer, unless NXP Semiconductors and customer have explicitly agreed otherwise in writing. In no event however, shall an agreement be valid in which the NXP Semiconductors product is deemed to offer functions and qualities beyond those described in the Product data sheet.

14.3 Disclaimers

Limited warranty and liability — Information in this document is believed to be accurate and reliable. However, NXP Semiconductors does not give any representations or warranties, expressed or implied, as to the accuracy or completeness of such information and shall have no liability for the consequences of use of such information.

In no event shall NXP Semiconductors be liable for any indirect, incidental, punitive, special or consequential damages (including - without limitation - lost profits, lost savings, business interruption, costs related to the removal or replacement of any products or rework charges) whether or not such damages are based on tort (including negligence), warranty, breach of contract or any other legal theory.

Notwithstanding any damages that customer might incur for any reason whatsoever, NXP Semiconductors' aggregate and cumulative liability towards customer for the products described herein shall be limited in accordance with the *Terms and conditions of commercial sale* of NXP Semiconductors.

Right to make changes — NXP Semiconductors reserves the right to make changes to information published in this document, including without limitation specifications and product descriptions, at any time and without notice. This document supersedes and replaces all information supplied prior to the publication hereof.

Suitability for use — NXP Semiconductors products are not designed, authorized or warranted to be suitable for use in life support, life-critical or safety-critical systems or equipment, nor in applications where failure or

malfunction of an NXP Semiconductors product can reasonably be expected to result in personal injury, death or severe property or environmental damage. NXP Semiconductors accepts no liability for inclusion and/or use of NXP Semiconductors products in such equipment or applications and therefore such inclusion and/or use is at the customer's own risk.

Applications — Applications that are described herein for any of these products are for illustrative purposes only. NXP Semiconductors makes no representation or warranty that such applications will be suitable for the specified use without further testing or modification.

Customers are responsible for the design and operation of their applications and products using NXP Semiconductors products, and NXP Semiconductors accepts no liability for any assistance with applications or customer product design. It is customer's sole responsibility to determine whether the NXP Semiconductors product is suitable and fit for the customer's applications and products planned, as well as for the planned application and use of customer's third party customer(s). Customers should provide appropriate design and operating safeguards to minimize the risks associated with their applications and products.

NXP Semiconductors does not accept any liability related to any default, damage, costs or problem which is based on any weakness or default in the customer's applications or products, or the application or use by customer's third party customer(s). Customer is responsible for doing all necessary testing for the customer's applications and products using NXP Semiconductors products in order to avoid a default of the applications and the products or of the application or use by customer's third party customer(s). NXP does not accept any liability in this respect.

Limiting values — Stress above one or more limiting values (as defined in the Absolute Maximum Ratings System of IEC 60134) will cause permanent damage to the device. Limiting values are stress ratings only and (proper) operation of the device at these or any other conditions above those given in the Recommended operating conditions section (if present) or the Characteristics sections of this document is not warranted. Constant or repeated exposure to limiting values will permanently and irreversibly affect the quality and reliability of the device.

Terms and conditions of commercial sale — NXP Semiconductors products are sold subject to the general terms and conditions of commercial sale, as published at <http://www.nxp.com/profile/terms>, unless otherwise agreed in a valid written individual agreement. In case an individual agreement is concluded only the terms and conditions of the respective agreement shall apply. NXP Semiconductors hereby expressly objects to applying the customer's general terms and conditions with regard to the purchase of NXP Semiconductors products by customer.

No offer to sell or license — Nothing in this document may be interpreted or construed as an offer to sell products that is open for acceptance or the grant, conveyance or implication of any license under any copyrights, patents or other industrial or intellectual property rights.

Export control — This document as well as the item(s) described herein may be subject to export control regulations. Export might require a prior authorization from national authorities.

Non-automotive qualified products — Unless this data sheet expressly states that this specific NXP Semiconductors product is automotive qualified, the product is not suitable for automotive use. It is neither qualified nor tested in accordance with automotive testing or application requirements. NXP Semiconductors accepts no liability for inclusion and/or use of non-automotive qualified products in automotive equipment or applications.

In the event that customer uses the product for design-in and use in automotive applications to automotive specifications and standards, customer (a) shall use the product without NXP Semiconductors' warranty of the product for such automotive applications, use and specifications, and (b) whenever customer uses the product for automotive applications beyond

NXP Semiconductors' specifications such use shall be solely at customer's own risk, and (c) customer fully indemnifies NXP Semiconductors for any liability, damages or failed product claims resulting from customer design and use of the product for automotive applications beyond NXP Semiconductors' standard warranty and NXP Semiconductors' product specifications.

14.4 Trademarks

Notice: All referenced brands, product names, service names and trademarks are the property of their respective owners.

15. Contact information

For more information, please visit: <http://www.nxp.com>

For sales office addresses, please send an email to: salesaddresses@nxp.com

16. Contents

1	General description	1
2	Features and benefits	1
2.1	System integration	1
2.2	General	1
2.3	Burner lifetime	1
2.4	Safety	1
2.5	Ease of use	2
3	Applications	2
4	Ordering information	2
5	Block diagram	3
6	Pinning information	4
6.1	Pinning	4
6.2	Pin description	4
7	Functional description	5
7.1	Supply voltage	5
7.2	Start-up state	5
7.3	Reset	5
7.4	Oscillation control	5
7.5	Preheat state	6
7.6	Ignition state	7
7.7	Steady state	7
7.8	Non-overlap time	8
7.9	OverTemperature Protection (OTP)	8
7.10	Minimum glow time control	8
7.11	Saturation Current Protection (SCP)	9
7.12	Capacitive Mode Protection (CMP)	9
8	Limiting values	10
9	Thermal characteristics	10
10	Characteristics	11
11	Application information	13
12	Package outline	15
13	Revision history	17
14	Legal information	18
14.1	Data sheet status	18
14.2	Definitions	18
14.3	Disclaimers	18
14.4	Trademarks	19
15	Contact information	19
16	Contents	20

Please be aware that important notices concerning this document and the product(s) described herein, have been included in section 'Legal information'.

© NXP B.V. 2011.

All rights reserved.

For more information, please visit: <http://www.nxp.com>

For sales office addresses, please send an email to: salesaddresses@nxp.com

Date of release: 26 August 2011

Document identifier: UBA2211