

January 1991

CMOS Parallel Interface

Features

- 24 Individual Programmed I/O Pins
- MOTEL Circuit for Bus Compatibility With Many Microprocessors
- Multiplexed Bus Compatible With CDP6805E2 and Competitive Microprocessors
- Data Direction Registers for Ports A, B and C
- Reset Input to Clear Interrupts and Initialize Internal Registers
- Four Port C I/O Pins May Be Used as Control Lines
 - ▶ Four Interrupt Inputs
 - ▶ Input Byte Latch
 - ▶ Output Pulse
 - ▶ Handshake Activity
- 15 Registers Addressed as Memory Locations
- Handshake Control Logic for Input and Output Peripheral Operation
- Interrupt Output Pin
- 3V to 5.5V Operating VDD

Description

The CDP6823 CMOS parallel interface (CPI) provides a universal means of interfacing external signals with the CDP6805E2 CMOS microprocessor and other multiplexed bus microprocessors. The unique MOTEL circuit on chip allows direct interfacing to most industry CMOS microprocessors, as well as many NMOS MPUs.

The CDP6823 CPI includes three bidirectional 8-bit ports or 24 I/O pins. Each I/O line may be separately established as an input or an output under program control via data direction registers associated with each port. Using the bit change and test instructions of the CDP6805E2, each individual I/O pin can be separately accessed. All port registers are read/write bytes to accommodate read-modify-write instructions.

The CDP6823 is supplied in a 40 lead hermetic dual-in-line sidebraced ceramic package (D suffix), in a 40 lead dual-in-line plastic package (E suffix) and in a 44 lead plastic chip carrier package (Q suffix).

The CDP6823 is equivalent to and is a direct replacement for the industry type MC146823.

Block Diagram

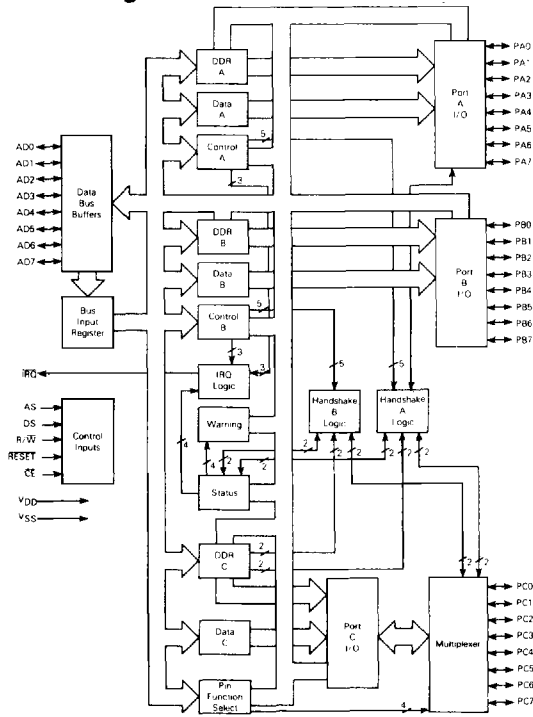

Pinouts

PACKAGE TYPES D AND E
TOP VIEW

PC2	1	40	VDD
PC1	2	39	PC3
PC0	3	38	PC4/CA1
PA0	4	37	PC5/CA2
PA1	5	36	PC6/CB
PA2	6	35	PC7/CB2
PA3	7	34	PB0
PA4	8	33	PB1
PA5	9	32	PB2
PA6	10	31	PB3
PA7	11	30	PB4
AD0	12	29	PB5
AD1	13	28	PB6
AD2	14	27	PB7
AD3	15	26	IRG
AD4	16	25	RESET
AD5	17	24	DS
AD6	18	23	R/W
AD7	19	22	AS
VSS	20	21	CE

PACKAGE TYPE Q

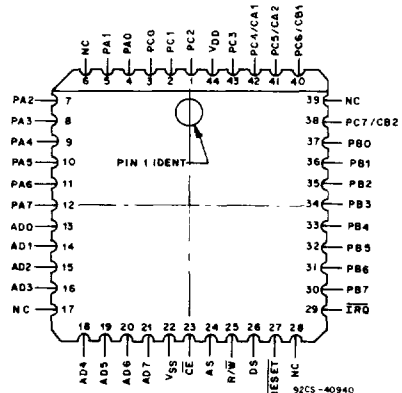

MAXIMUM RATINGS (Voltages reference to V_{SS})

Ratings	Symbol	Value	Unit
Supply Voltage	V _{DD}	-0.3 to +8	V
All Input Voltages	V _{in}	V _{SS} -0.5 to V _{DD} +0.5	V
Current Drain per Pin Excluding V _{DD} and V _{SS}	I	10	mA
Operating Temperature Range	T _A	-40 to +85	°C
Storage Temperature Range	T _{stg}	-55 to +150	°C

THERMAL CHARACTERISTICS

Characteristics	Symbol	Value	Unit
Thermal Resistance Ceramic Dual-In-Line	θ _{JA}	50	°C/W
Plastic Dual-In-Line		100	
Plastic Chip-Carrier		70	

This device contains circuitry to protect the inputs against damage due to high static voltages or electric fields; however, it is advised that normal precautions be taken to avoid application of any voltage higher than maximum rated voltages to this high-impedance circuit. For proper operation it is recommended that V_{in} and V_{out} be constrained to the range V_{SS} ≤ (V_{in} or V_{out}) ≤ V_{DD}. Leakage currents are reduced and reliability of operation is enhanced if unused inputs are tied to an appropriate logic voltage level (e.g., either V_{SS} or V_{DD}).

DC ELECTRICAL CHARACTERISTICS (V_{DD}=5 Vdc ± 10%, V_{SS}=0 Vdc, T_A=0°C to 70°C, unless otherwise noted)

Parameter	Symbol	Min	Max	Unit
Output Voltage (I _{Load} ≤ 10 μA)	V _{OL} V _{OH}	- V _{DD} -0.1	0.1 -	V
Output High Voltage (I _{Load} = -1.6 mA) AD0-AD7 (I _{Load} = -0.2 mA) PA0-PA7, PC0-PC7 (I _{Load} = -0.36 mA) PB0-PB7	V _{OH} V _{OH} V _{OH}	4.1 4.1 4.1	V _{DD} V _{DD} V _{DD}	V
Output Low Voltage (I _{Load} = 1.6 mA) AD0-AD7, PB0-PB7 (I _{Load} = 0.8 mA) PA0-PA7, PC0-PC7 (I _{Load} = 1 mA) IRQ	V _{OL} V _{OL} V _{OL}	V _{SS} V _{SS} V _{SS}	0.4 0.4 0.4	V
Input High Voltage, AD0-AD7, AS, DS, R/W, CE, PA0-PA7, PB0-PB7, PC0-PC7 RESET	V _{IH} V _{IH}	V _{DD} -2.0 V _{DD} -0.8	V _{DD} V _{DD}	V
Input Low Voltage (All Inputs)	V _{IL}	V _{SS}	0.8	V
Quiescent Current — No dc Loads (All Ports Programmed as Inputs, All Inputs = V _{DD} - 0.2 V)	I _{DD}	-	160	μA
Total Supply Current (All Ports Programmed as Inputs, CE = V _{IL} , t _{cy} = 1 μs)	I _{DD}	-	3	mA
Input Current, CE, AS, R/W, DS, RESET	I _{in}	-	±1	μA
Hi-Z State Leakage, AD0-AD7, PA0-PA7, PB0-PB7, PC0-PC7	I _{TSL}	-	±10	μA

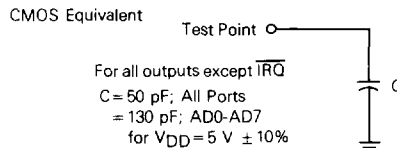
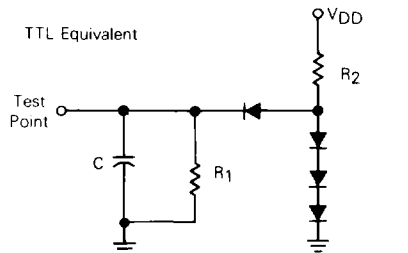

Pin	R1	R2	C
AD0-AD7	2.55k	2 k	130 pF
PA0-PA7, PC0-PC7	2.2 k	4.32k	50 pF
PB0-PB7	11.5k	2.1k	50 pF

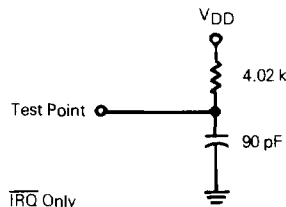

Fig. 2 - Equivalent test loads.

8-BIT BUS PERIPHERALS

CDP6823

BUS TIMING ($V_{DD}=5\text{ Vdc} \pm 10\%$, $V_{SS}=0\text{ Vdc}$, $T_A=0^\circ\text{ to }70^\circ\text{C}$, unless otherwise noted)

Ident. Number	Characteristics	Symbol	Min	Max	Unit
1	Cycle Time	t_{cyc}	1000	dc	ns
2	Pulse Width, DS/E Low or RD/WR High	PWEL	300	—	ns
3	Pulse Width, DS/E High or RD/WR Low	PWEH	325	—	ns
4	Input Rise and Fall Time	t_r, t_f	—	30	ns
8	R/W Hold Time	t_{RWH}	10	—	ns
13	R/W and CE Setup Time Before DS/E	t_{RWS}	25	—	ns
15	Chip Enable Hold Time	t_{CH}	0	—	ns
18	Read Data Hold Time	t_{DHR}	10	100	ns
21	Write Data Hold Time	t_{DHW}	0	—	ns
24	Muxed Address Valid Time to AS/ALE Fall	t_{ASL}	25	—	ns
25	Muxed Address Hold Time	t_{AHL}	20	—	ns
26	Delay Time DS/E to AS/ALE Rise	t_{ASD}	60	—	ns
27	Pulse Width, AS/ALE High	PWASH	170	—	ns
28	Delay Time, AS/ALE to DS/E Rise	t_{ASED}	60	—	ns
30	Peripheral Output Data Delay Time from DS/E or RD	t_{DDR}	20	240	ns
31	Peripheral Data Setup Time	t_{DSW}	220	—	ns

NOTE: Designations E, ALE, RD, and WR refer to signals from alternative microprocessor signals.

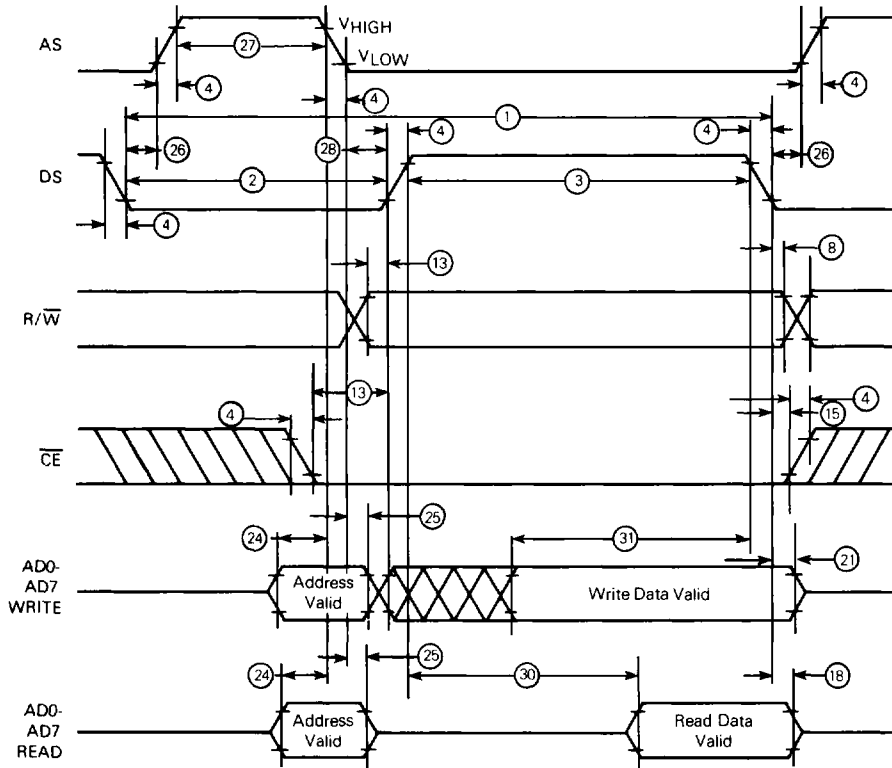

NOTE: $V_{HIGH}=V_{DD}-2\text{ V}$, $V_{LOW}=0.8\text{ V}$, for $V_{DD}=5\text{ V} \pm 10\%$

Fig. 3 - Bus timing diagram.

CDP6823

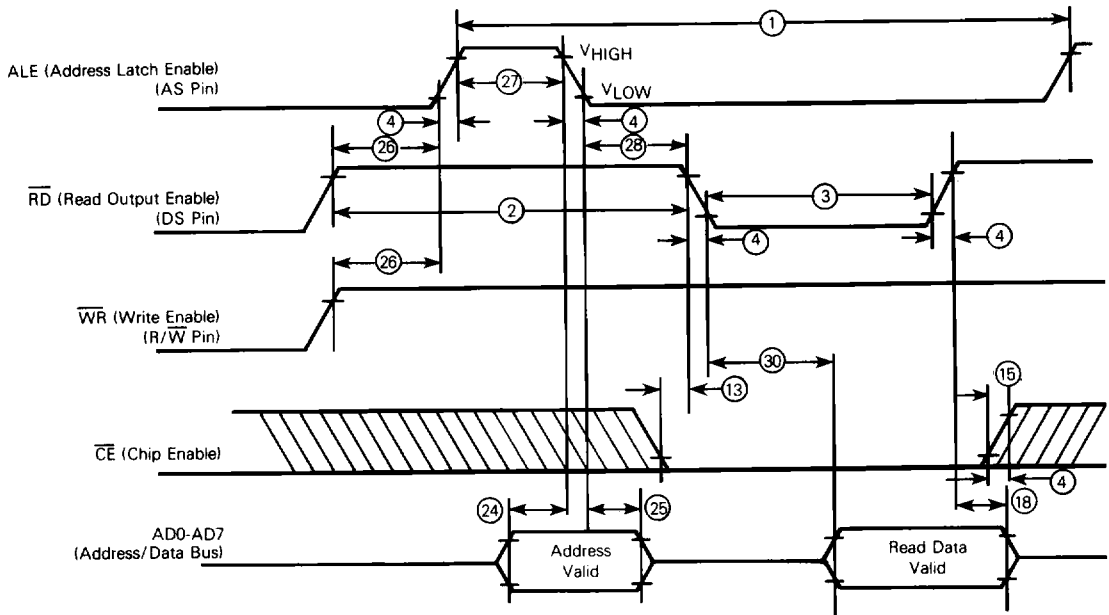
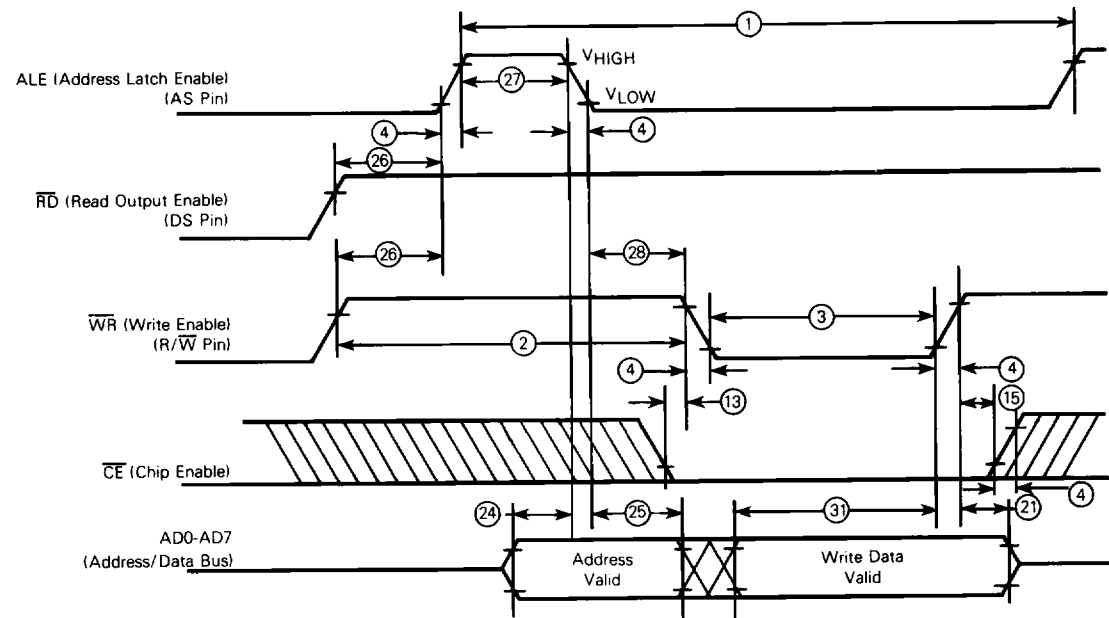

Fig. 4 - Bus READ timing competitor multiplexed bus.



NOTE: $V_{HIGH} = V_{DD} - 2V$, $V_{LOW} = 0.8V$, for $V_{DD} = 5V \pm 10\%$

Fig. 5 - Bus WRITE timing competitor multiplexed bus.

5
8-BIT BUS
PERIPHERALS

CDP6823

CONTROL TIMING ($V_{DD} = 5.0V_{dc} \pm 10\%$, $V_{SS} = 0V_{dc}$, $T_A = 0^{\circ}C$ to $70^{\circ}C$)

PARAMETER	SYMBOL	MIN	MAX	UNIT
Interrupt Response (Input Modes 1 and 3)	t_{RQR}	-	1.0	μs
Delay, CA1 (CB1) Active Transition to CA2 (CB2) High (Output Mode 0)	t_{C2}	-	1.0	μs
Delay, CA2 Transition from Positive Edge of AS (Output Modes 0 and 1)	t_{A2}	-	1.0	μs
Delay, CD2 Transition from Negative Edge of AS (Output Modes 0 and 1)	t_{B2}	-	1.0	μs
CA2/CB2 Pulse Width (Output Mode 1)	t_{PW}	0.5	1.5	μs
Delay, V_{DD} Rise to \overline{RESET} High	t_{RLH}	1.0	-	μs
Pulse Width, \overline{RESET}	t_{RW}	1.0	-	μs

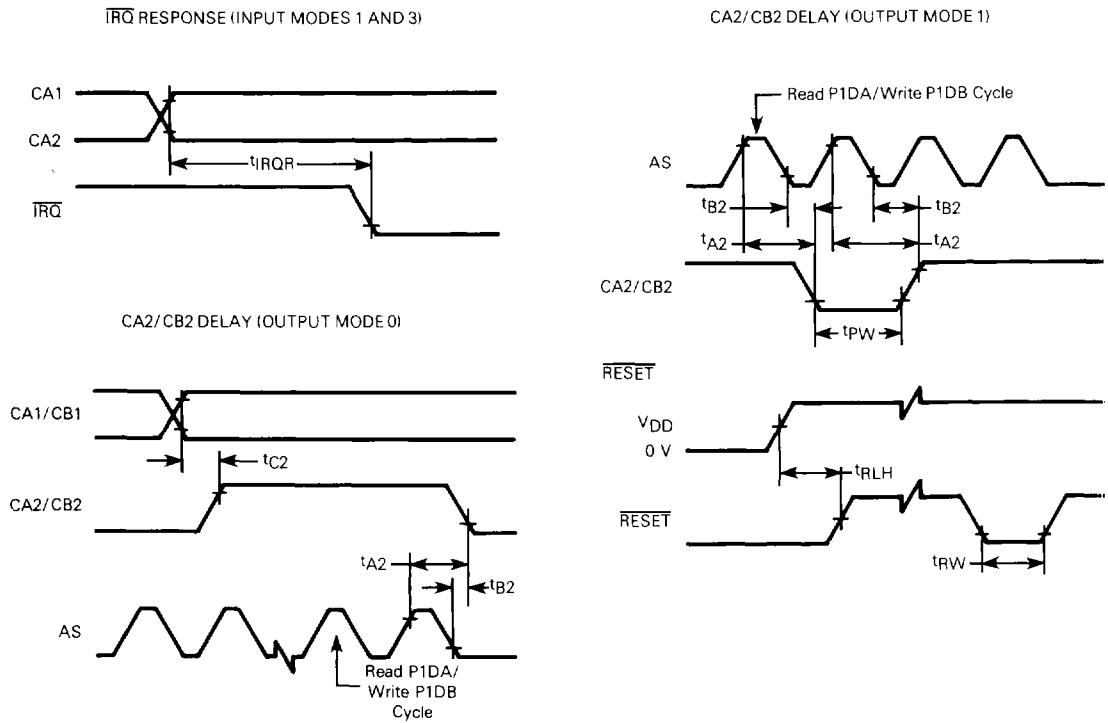

Fig. 6 - Control timing diagrams.

GENERAL DESCRIPTION

The CDP6823, CMOS parallel interface (CPI), contains 24 individual bidirectional I/O lines configured in three 8-bit ports. The 15 internal registers, which control the mode of operation and contain the status of the port pins, are accessed via an 8-bit multiplexed address/data bus. The lower four address bits (AD0-AD3) of the multiplexed address bus determine which register is to be accessed (see Register Address Map shown below). The four address bits (AD4, AD5, AD6, and AD7) must be separately decoded to position this memory map within each 256-byte address space available via the 8-bit multiplexed address bus. For more detailed information, refer to **REGISTER DESCRIPTION**.

REGISTER ADDRESS MAP

0	Port A Data, Clear CA1 Interrupt	P1DA
1	Port A Data, Clear CA2 Interrupt	P2DA
2	Port A Data	PDA
3	Port B Data	PDB
4	Port C Data	PDC
5	Not Used	--
6	Data Direction Register for Port A	DDRA
7	Data Direction Register for Port B	DDRB
8	Data Direction Register for Port C	DDRC
9	Control Register for Port A	CRA
A	Control Register for Port B	CRB
B	Pin Function Select Register for Port C	FSR
C	Port B Data, Clear CB1 Interrupt	P1DB
D	Port B Data, Clear CB2 Interrupt	P2DB
E	Handshake/Interrupt Status Register	HSR
F	Handshake Over-Run Warning Register	HWR

The CPI is implemented with the MOTEL circuit which allows direct interface with either of the two major multiplexed microprocessor bus types. A detailed description of the MOTEL circuit is provided in the **MOTEL** section.

Three data direction registers (DDRs), one for each port, determine which pins are outputs and which are inputs. A logic zero on a DDR bit configures its associated pin as an input; and a logic one configures the pin as an output. Upon reset, the DDrs are cleared to logic zero to configure all port pins as inputs.

Actual port data may be read or written via the port data registers (PDA, PDB, and PDC). Ports A and B each have two additional data registers (P1DA and P2DA - P1DB and P2DB) which are used to clear the associated handshake/interrupt status register bits (HSA1 and HSA2 - HSB1 and HSB2), respectively. Port A may also be configured as an 8-bit latch when used with CA1. Reset has no effect on the contents of the port data registers. Users are advised to initialize the port data registers before changing any port pin to an output.

Four pins on port C (PC4/CA1, PC5/CA2, PC6/CB1, and PC7/CB2) may additionally be programmed as handshake lines for ports A and B via the port C function select register (FSR). Both ports A and B have one input-only line and one bidirectional handshake line each associated with them. The handshake lines may be programmed to perform a variety of tasks such as interrupt requests, setting flags, latching data, and data transfer requests and/or acknowledgments. The handshake functions are programmed via control registers A and B (CRA and CRB). Additional information may be found in **PIN DESCRIPTIONS**, **REGISTER DESCRIPTION**, or **HANDSHAKE OPERATION**.

MOTEL

The MOTEL circuit is a concept that permits the CDP6823 to be directly interfaced with different types of multiplexed bus microprocessors without any additional external logic. For a more detailed description of the multiplexed bus, see **MULTIPLEXED BIDIRECTIONAL ADDRESS/DATA BUS (AD0-AD7)**. Most multiplexed microprocessors use one of two synchronous buses to interface peripherals. An industry standard bus structure is now available.

The MOTEL circuit is built into peripheral and memory ICs to permit direct connection to either type of bus. The MOTEL concept is shown logically in Fig. 7.

The microprocessor type is automatically selected by the MOTEL circuit through latching the state of the DS/ \overline{RD} pin with AS/ALE. Since DS is always low during AS and \overline{RD} is always high during ALE, the latch automatically indicates with which type microprocessor bus it is interfaced.

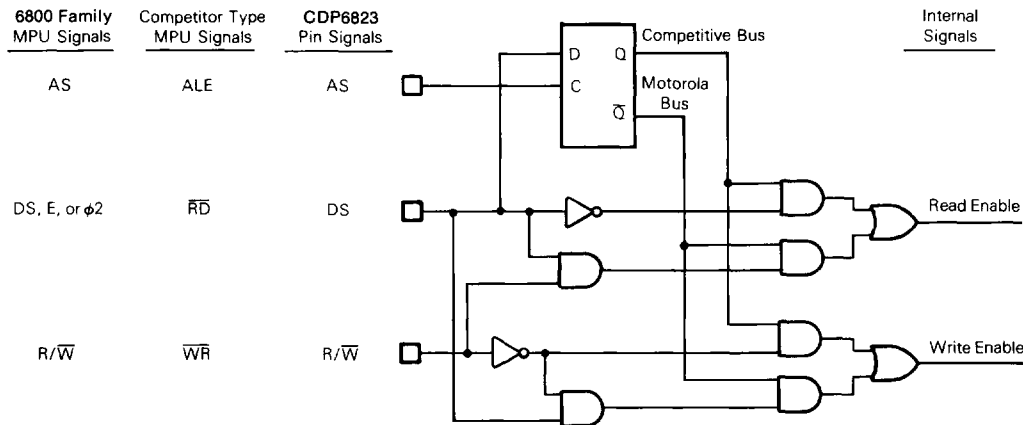

Fig. 7 - Functional diagram of MOTEL circuit.

5
8-BIT BUS PERIPHERALS

PIN DESCRIPTION

The following paragraphs contain a brief description of the input and output pins. References (if applicable) are given to other paragraphs that contain more detail about the function being performed.

Multiplexed Bidirectional Address/Data Bus (AD0-AD7)

Multiplexed bus processors save pins by presenting the address during the first portion of the bus cycle and using the same pins during the second portion of the bus cycle for data. Address-then-data multiplexing does not slow the access time of the CDP6823 since the bus reversal from address to data is occurring during the internal register access time.

The address must be valid t_{ASL} prior to the fall of AS/ALE at which time the CDP6823 latches the address present on the AD0-AD3 pins. Valid write data must be presented and held stable during the latter portion of the DS or WR pulses. In a read cycle, the CDP6823 outputs eight bits of data during the latter portion of the DS or RD pulses, then ceases driving the bus (returns the output drivers to high impedance) t_{DHR} hold time after DS falls in this case of MOTEL or RD rises in the other case.

Address Strobe (AS)

The address strobe input pulse serves to demultiplex the bus. The falling edge of AS or ALE causes the addresses AD0-AD3 to be latched within the CDP6823. The automatic MOTEL circuit in the CDP6823 also latches the state of the DS pin with the falling edge of AS or ALE.

Data Strobe or Read (DS)

The DS input pin has two interpretations via the MOTEL circuit. When generated by a Motorola microprocessor, DS is a positive pulse during the latter portion of the bus cycle, and is variously called DS (data strobe), E (enable), or $\phi 2$ ($\phi 2$ clock). During read cycles, DS or RD signifies the time that the CPI is to drive the bidirectional bus. In write cycles, the trailing edge of DS or rising edge of WR causes the parallel interface to latch the written data present on the bidirectional bus.

The second MOTEL interpretation of DS is that of RD, MEMR, or T/OR originating from a competitor-type micro processor. In this case, DS identifies the time period when the parallel interface drives the bus with read data. This interpretation of DS is also the same as an output-enable signal on a typical memory.

The MOTEL circuit, within the CDP6823, latches the state of the DS pin on the falling edge of AS/ALE. When the mode of MOTEL is desired DS must be low during AS/ALE, which is the case with the multiplexed bus microprocessors. To insure the competitor mode of MOTEL, the DS pin must remain high during the time AS/ALE is high.

Read/Write (R/W)

The MOTEL circuit treats the R/W input pin in one of two ways. The microprocessor is connected, R/W is a level which indicates whether the current cycle is a read or write. A read cycle is indicated with a high level on R/W while DS is high, whereas a write cycle is a low on R/W while DS is high.

The second interpretation of R/W is as a negative write pulse, WR, MEMW, and T/OW from competitor-type micro processors. The MOTEL circuit in this mode gives the R/W pin the same meaning as the write (W) pulse on many generic RAMs.

Chip Enable (CE)

The CE input signal must be asserted (low) for the bus cycle in which the CDP6823 is to be accessed. CE is not latched and must be stable prior to and during DS (in the 6805 mode of MOTEL) and prior to and during RD and WR (in the competitor mode of MOTEL). Bus cycles which take place without asserting CE cause no actions to take place within the CDP6823. When CE is high, the multiplexed bus output is in a high-impedance state.

When CE is high, all data, DS, and R/W inputs from the microprocessor are disconnected within the CDP6823. This permits the CDP6823 to be isolated from a powered-down microprocessor.

Reset (RESET)

The RESET input pin is an active-low line that is used to restore all register bits, except the port data register bits, to logical zeros. After reset, all port lines are configured as inputs and no interrupt or handshake lines are enabled.

Interrupt Request (IRQ)

The IRQ output line is an open-drain active-low signal that may be used to interrupt the microprocessor with a service request. The "open-drain" output allows this and other interrupt request lines to be wire ORed with a pullup resistor. The IRQ line is low when bit 7 of the status register is high. Bit 7 (IRQF) of the handshake/Interrupt status register (HSR) is set if any enabled handshake transition occurs; and its associated control register bit is set to allow interrupts. Refer to **INTERRUPT DESCRIPTION** or **HANDSHAKE OPERATION** for additional information.

Port A, Bidirectional I/O Lines (PA0-PA7)

Each line of port A, PA0-PA7, is individually programmable as either an input or output via its data direction register (DDRA). An I/O pin is an input when its corresponding DDR bit is a logic zero and an output when the DDR bit is a logic one. See Fig. 8 for typical I/O circuitry and Table 1 for I/O operation.

TABLE 1 — PORT DATA REGISTER ACCESSES (ALL PORTS)

R/W	DDR Bit	Results
0	0	The I/O pin is in input mode. Data is written into the output data latch.
0	1	Data is written into the output data latch and output to the I/O pin.
1	0	The state of the I/O pin is read.
1	1	The I/O pin is in an output mode. The output data latch is read.

There are three data registers associated with port A: PDA, P1DA, and P2DA. P1DA and P2DA are accessed when certain handshake activity is desired. See **HANDSHAKE OPERATION** for more information.

Data written to the port A data register, PDA, is latched into the port A output latch regardless of the state of the DDRA. Data written to P1DA or P2DA is ignored and has no affect upon the output data latch or the I/O lines. An MPU read of port bits programmed as outputs reflect the last value written to the PDA register. Port A pins programmed as inputs may be latched via the handshake line PC4/CA1 (see

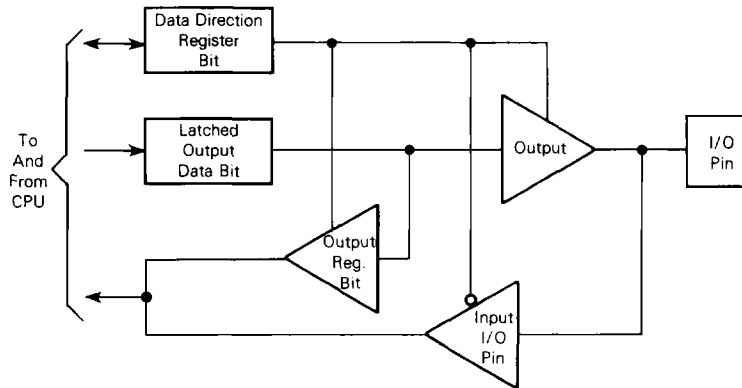

Fig. 8 - Typical port I/O circuitry.

HANDSHAKE OPERATION) and latched input data may be read via any of the three port A data registers. If the port A input latch feature is not enabled, an MPU read of any port A data register reflects the current status of the port A input pins if the corresponding DDRA bits equal zero. Reset has no effect upon the contents of the port A data register; however, all pins will be placed in the input mode (all DDRA bits forced to equal zero) and all handshake lines will be disabled.

Port B Bidirectional I/O Lines (PB0-PB7)

Each line of port B, PB0-PB7, is individually programmable as either an input or an output via its data direction register (DDRB). An I/O pin is an input when its corresponding DDR bit is a logic zero and an output when the DDR bit is a logic one.

There are three data registers associated with port B: PDB, P1DB, and P2DB. PDB is used for simple port B data reads and writes. P1DB and P2DB are accessed when certain handshake activity is desired. See **HANDSHAKE OPERATION** for more information.

Data written to PDB or P1DB data register is latched into the port B output latch regardless of the state of the DDRB. An MPU read of port bits programmed as outputs reflect the last value written to a port B data register. An MPU read of any port B register reflects the current status of the input pins whose DDRB bits equal zero. Reset has no effect upon the contents of the port B data register; however, all pins will be placed in the input mode (all DDRB bits forced to equal zero) and all handshake lines will be disabled.

Port C, Bidirectional I/O Lines (PC0-PC3)

Each line of port C, PC0-PC3, is individually programmable as either an input or an output via its data direction register (DDRC). An I/O pin is an input when its corresponding DDR bit is a logic zero and an output when the DDR bit is a logic one. Port C data register (PDC) is used for simple port C data reads and writes.

Data written into PDC is latched into the port C data latch regardless of the state of the DDRC. An MPU read of port C bits programmed as outputs reflect the last value written to the PDC register. An MPU read of the port C register reflects

the current status of the corresponding input pins whose DDRC bits equal zero. Reset has no effect upon the contents of the port C data register; however, all pins will be placed in the input mode (all DDRC bits forced to equal zero) and all handshake lines will be disabled.

Port C Bidirectional I/O Line or Port A Input Handshake Line (PC4/CA1)

This line may be programmed as either a simple port C I/O line or as a handshake line for port A via the port C function select register (FSR). If programmed as a port C I/O pin, PC4/CA1 performs as described in the PC0-PC3 pin description. If programmed as a port A handshake line, PC4/CA1 performs as described in **HANDSHAKE OPERATION**.

Port C Bidirectional I/O Line or Port A Bidirectional Handshake Line (PC5/CA2)

This line may be programmed as either a simple port C I/O line or as a handshake line for port A via the port C function select register (FSR). If programmed as a port C I/O pin, PC5/CA2 performs as described in the PC0-PC3 pin description. If programmed as a port A handshake line, PC5/CA2 performs as described in **HANDSHAKE OPERATION**.

Port C Bidirectional I/O Line or Port B Input Handshake Line (PC6/CB1)

This line may be programmed as either a simple port C I/O line or as a handshake line for port B via the port C function select register (FSR). If programmed as a port C I/O pin, PC6/CB1 performs as described in the PC0-PC3 pin description. If programmed as a port B handshake line, PC6/CB1 performs as described in **HANDSHAKE OPERATION**.

Port C Bidirectional I/O Line or Port B Bidirectional Handshake Line (PC7/CB2)

This line may be programmed as either a simple port C I/O line or as a handshake line for port B via the port C function select register (FSR). If programmed as a port C I/O line, PC7/CB2 performs as described in the PC0-PC3 pin description. If programmed as a port B handshake line, PC7/CB2 performs as described in **HANDSHAKE OPERATION**.

HANDSHAKE OPERATION

Up to four port C pins can be configured as handshake lines for ports A and B (one input-only and one bidirectional line for each port) via the port C function select register (FSR). The direction of data flow for the two bidirectional handshake lines (CA2 and CB2) is determined by bits 5 and 7, respectively, of the port C data direction register (DDRC). Actual handshake operation is defined by the appropriate port control register (CRA or CRB).

The control registers allow each handshake line to be programmed to operate in one of four modes. CA2 and CB2 each have four input and four output modes. For detailed information, see Tables 2 and 3.

A summary of the handshake modes is given in the input and output sections that follow. All handshake activity is disabled by reset.

Input

Handshake lines programmed as inputs operate in any of

four different modes as defined by the control registers (see Table 2). A bit in the handshake/interrupt status register (HSR) is set to a logic one on an active transition of any handshake line programmed as an input. Modes 0 and 1 define a negative transition as active; modes 2 and 3 define a positive transition as active. If modes 1 or 3 are selected on any input handshake line then the active transition of that line results in the IRQF bit of the HSR being set to a logic one and causes the interrupt line (IRQ) to go low. IRQ is released by clearing the HSR bits that are input handshake lines which have interrupts enabled.

If an active transition occurs while the associated HSR bit is set to a logic one, the corresponding bit in the handshake warning register (HWR) is set to a logic one indicating that service of at least one active transition was missed. An HWR bit is cleared to a logic zero by first accessing the appropriate port data register, to clear the appropriate HSR status bit, followed by a read of the HWR.

TABLE 2 — INPUT HANDSHAKE MODES

Mode	Control Register Bits*	Active Edge	Status Bit In HSR	IRQ Pin
0	00	- Edge	Set high on active edge.	Disabled
1	01	- Edge	Set high on active edge.	Goes low when corresponding status flag in HSR goes high.
2	10	+ Edge	Set high on active edge.	Disabled
3	11	+ Edge	Set high on active edge.	Goes low when corresponding status flag in HSR goes high.

* Cleared to logic zero on reset.

TABLE 3 — OUTPUT HANDSHAKE LINES (CA2 AND CB2 ONLY)

Mode	Control Register CRA(B) Bits 3 and 4*	Handshake Line Set High	Handshake Line Cleared Low	Default Level
0	00	Handshake set high on active transition of CA1 input. Handshake set high on active transition of CB1 input.	Read of P1DA or a read of P2DA while HSA1 is cleared. Write of port B P1DB or write of P2DB while HSB1 is cleared.	High
1	01	High on the first positive (negative) transition of AS while CA2 (CB2) is low.	Low on the first positive (negative) transition on AS following a read (write) of port A(B) data registers P1DA(B) or P2DA(B).	High
2	10	Never	Always	Low
3	11	Always	Never	High

* Cleared to logic zero on reset.

Input Latch

Port A input-only handshake line (PC4/CA1) can be programmed to function as a latch enable for port A input data via CA1 LE (bit 2 of CRA). If CA1 LE is programmed to a logic one, an active transition of PC4/CA1 will latch the current status of the port A input pins into all three port A data registers (PDA, P1DA, and P2DA). When CA1 LE is enabled, port A and PC4/CA1 function as an 8-bit transparent latch; that is, if the HSA1 bit in the HSR is a logic zero then a read of any port A register reflects the current state of the port A input pins and corresponding bits of the output data latch for port A output pins. If HSA1 is a logic one, a read of any port A data register reflects the state of the port A input pins when HSA1 was set and the corresponding bits of the port A output data latch for port A output pins.

Further transitions of PC4/CA1 result only in setting the HWA1 bit in the HWR and do not relatch data into the port A registers. Latched data is released only by clearing HSA1 in the HSR to a logic zero (HSA1 is cleared by reading P1DA).

Output

Each bidirectional handshake line programmed as an output by the DDRC operates in one of four modes as described in Table 3. Modes 2 and 3 force the output handshake line to reflect the state of bit 4 in the appropriate control register.

In modes 0 and 1, PC5/CA2 is forced low during the cycle following a read of P1DA or a read of P2DA while HSA1 is cleared. PC7/CB2 is forced low during the cycle following a write to P1DB or a write to P2DB while HSB1 is cleared. Because of these differences, port A is the preferred input port and port B is the preferred output port.

In mode 0, PC5/CA2 (PC7/CB2) is set high by an active transition of PC4/CA1 (PC6/CB1). In mode 1, PC5/CA2 (PC7/CB2) is set high in the cycle following the cycle in which PC5/CA2 (PC7/CB2) goes low. Mode 1 forces a low-going pulse on PC5/CA2 (PC7/CB2) following a read (write) of P1DA (P1DB) or P2DA (P2DB) that is approximately one cycle time wide.

When entering an output handshake mode for the first time after a reset, the handshake line outputs the default level as listed in Table 3.

INTERRUPT DESCRIPTION

The CDP6823 allows an MPU interrupt request (IRQ low) via the input handshake lines. The input handshake line, operating in modes 1 or 3 as defined by the control registers (CRA and CRB), causes \overline{IRQ} to go low when IRQF (interrupt flag) in the HSR is set to a logic one. \overline{TRQ} is released when IRQF is cleared. See **Handshake/Interrupt Status Register** under **REGISTER DESCRIPTION** for additional information.

REGISTER DESCRIPTION

The CDP6823 has 15 registers (see Fig. 1) which define the mode of operation and status of the port pins. The following paragraphs describe these registers.

Register Names:

- Control Register A (CRA)
- Control Register B (CRB)

Register Addresses:

- \$9 (CRA)
- \$A (CRB)

Register Bits:

	7	6	5	4	3	2	1	0
\$9	X	X	X	CA2 Mode	CA1 LE		CA1 Mode	
\$A	X	X	X	CB2 Mode		X	CB1 Mode	

Purpose:

These two registers control the handshake and interrupt activity for those pins defined as handshake lines by the port C function select register (FSR).

Description:

CA2 and CB2 are programmed as inputs or outputs via the associated DDRC bits. Each handshake line is controlled by two mode bits. Bit 2 of CRA enables the Port A latch for an active CA1 transition. Table 2 describes the input handshake modes (CA1, CB1, CA2, CB2) and Table 3 describes the output handshake modes for CA2 and CB2.

Register Names:

- Port A Data Registers (PDA, P1DA, P2DA)

Register Addresses:

- \$2 (PDA), \$0 (P1DA), \$1 (P2DA)

Register Bits:

	7	6	5	4	3	2	1	0
Bit 7	Bit 6	Bit 5	Bit 4	Bit 3	Bit 2	Bit 1	Bit 0	

Purpose:

These three registers serve different purposes. PDA is used to read input data and latch data written to the port A output pins. P1DA and P2DA are used to read input data and to affect handshake and status activity for PC4/CA1 and PC5/CA2. If enabled, port A input data may be latched into the three port A data registers on an active PC4/CA1 transition as described in **HANDSHAKE OPERATION**.

Description:

Data written into PDA is latched into the port A output latch (see Fig. 3) regardless of the state of DDRA. Output pins, as defined by DDRA, assume the logic levels of the corresponding bits in the PDA output latch. The PDA output latch allows the user to read the state of the port A output data. If the input latch is not enabled, a read of any port A data register reflects the current state of the port A input pins as defined by DDRA and the contents of the output latch for output pins. Writes into P1DA or P2DA have no effect upon the output pins or the output data latch. Users are recommended to initialize the port A output latch before changing any pin to an output via the DDRA.

MPU accesses of P1DA or P2DA are primarily used to affect handshake and status activity. A summary of the effects on the status and warning bits of port A data register accesses is given in Table 4. For more information, see **HANDSHAKE OPERATION and Control Register A (CRA)** under **REGISTER DESCRIPTION**. Reset has no effect upon the contents of any port A data register.

Register Names:

Port B Data Registers (PDB, P1DB, P2DB)

Register Addresses:

\$3 (PDB), \$C (P1DB), \$D (P2DB)

Register Bits:

7	6	5	4	3	2	1	0
Bit 7	Bit 6	Bit 5	Bit 4	Bit 3	Bit 2	Bit 1	Bit 0

Purpose:

These three registers serve different purposes. The Port B data registers are used to read input data and to latch data written to the port B output pins. Writes to PDB and P1DB affect the contents of the output data latch while writes to P2DB do not affect the output data latch. P1DB and P2DB accesses additionally affect handshake and status activity for PC6/CB1 and PC7/CB2.

Description:

Data written into PDB and P1DB port B registers is latched into the port B output latch (see Fig. 3) regardless of the state of DDRB. Output pins, as defined by DDRB, assume the logic levels of the corresponding bits in the port B output latch. Reads of any port B data registers reflect the contents of the output data latch for output pins and the current state of the input pins (as determined by DDRB). Users are recommended to initialize the port B output latch before changing any pin to an output via the DDRB.

MPU accesses of P1DB or P2DB are primarily used to affect handshake and status activity. A summary of the effects on status and warning register bits of port B data register accesses is given in Table 5. For more information, see **HANDSHAKE OPERATION or Control Register B (CRB)** under **REGISTER DESCRIPTION**. Reset has no effect upon the contents of any port B data register.

TABLE 4 — SUMMARY OF EFFECTS ON HANDSHAKE STATUS, WARNING BITS, AND OUTPUT LATCH BY PORT A DATA REGISTER ACCESSES

Register Accessed	HSR Bit	HWR Bit	Handshake Reaction	Output Latch	
				Read	Write
PDA	None	None	None	Yes	Yes
P1DA	HSA1 cleared to a logic zero.	HWA1 loaded into buffer latch.	CA2 goes low if output modes 0 or 1 are selected in the CRA.	Yes	No
P2DA	HSA2 cleared to a logic zero.	HWA2 loaded into buffer latch.	CA2 goes low if output modes 0 or 1 are selected in the CRA.	Yes	No

TABLE 5 — SUMMARY OF EFFECTS ON HANDSHAKE STATUS, WARNING BITS, AND OUTPUT LATCH BY PORT B DATA REGISTER ACCESSES

Register Accessed	HSR Bit	HWR Bit	Handshake Reaction	Output Latch	
				Read	Write
PDB	None	None	None	Yes	Yes
P1DB	HSB1 cleared to a logic zero.	HWB1 loaded into buffer latch.	CB2 goes low if output modes 0 or 1 are selected in the CRB.	Yes	Yes
P2DB	HSB2 cleared to a logic zero.	HWA2 loaded into buffer latch.	CB2 goes low if output modes 0 or 1 are selected in CRB.	Yes	No

Register Name:
Port C Data Register (PDC)

Register Address:
\$4

Register Bits:

7	6	5	4	3	2	1	0
Bit 7	Bit 6	Bit 5	Bit 4	Bit 3	Bit 2	Bit 1	Bit 0

Purpose:
The port C data register (PDC) is used to read input data and to latch data written to the output pins.

Description:
Data is written into the port C output latch (see Fig. 3) regardless of the state of DDRC. Any port C pin defined as a handshake line by the port C function select register (FSR) is not affected by PDC. Output pins, as defined by DDRC, assume logic levels of the corresponding bits in the port C output latch. A read of PDC reflects the contents of the output latch for output pins and the current state of the input pins (as reflected in the DDRC). Reset has no effect upon the contents of PDC. Users are recommended to initialize the port C output data latch before changing any pin to an output via the DDRC.

Register Name:
Data Direction Register for Port A (B) (C)

Register Address:
\$6 (\$7) (\$8)

Register Bits:

7	6	5	4	3	2	1	0
Bit 7	Bit 6	Bit 5	Bit 4	Bit 3	Bit 2	Bit 1	Bit 0

Purpose:
Each of the three data direction registers (DDRA, DDRB, and DDRC) define the direction of data flow of the port pins for ports A, B, and C.

Description:
A logic zero in a DDR bit places the corresponding port pin in the input mode. A logic one in a DDR bit places the corresponding pin in the output mode. Any port C pins defined as bidirectional handshake lines also use the port C DDR (DDRC). Input-only handshake lines are not affected by DDRC. Reset clears all DDR bits to logic zero configuring all port pins as inputs. The DDRs have no write-inhibit control over the port data output latches. Data may be written to the port data registers even though the pins are configured as inputs.

Register Name:
Port C Pin Function Select Register (FSR)

Register Address:
\$B

Register Bits:

7	6	5	4	3	2	1	0
CFB2	CFB1	CFA2	CFA1	XX	XX	XX	XX

Purpose:
The port C pin function select register defines whether the multifunction port C pins are to operate as "normal" port C lines or as handshake lines.

Description:
A logic zero in any FSR bit defines the corresponding port C pin as a "normal" I/O pin. A logic one in any valid FSR bit defines the corresponding port C pin as a handshake line. Pins defined as handshake lines function according to the contents of control register A (CRA) or control register B (CRB). The port C data direction register (DDRC) is valid regardless of FSR contents for all pins except PC4/CA1 and PC6/CB1. Transitions on port C pins not defined as handshake pins do not effect the handshake/interrupt status register. Reset clears all FSR bits to a logic zero. Users are recommended to initialize the data direction and control registers before modifying the FSR.

Register Name:
Handshake/Interrupt Status Register (HSR)

Register Address:
\$E

Register Bits:

7	6	5	4	3	2	1	0
IRQF	XX	XX	XX	HSB2	HSA2	HSB1	HSA1

Purpose:
The handshake interrupt status register is a read-only flag register that may be used during a polling routine to determine if any enabled input handshake transition, as defined by the control register (CRA and CRB), has occurred.

Description:
If an enabled input handshake transition occurs then the appropriate HSR bit (HSB2, HSA2, HSB1, or HSA1) is set. The IRQ flag bit (bit 7, IRQF) is set when one or more of the HSR bits 0-3 and their corresponding control register bits are set to a logic one as shown in the following equation:

$$\text{Bit 7} = \text{IRQF} = [\text{HSB2} \cdot \text{CRB2}(3)] + [\text{HSA2} \cdot \text{CRA2}(3)] + [\text{HSB1} \cdot \text{CRB1}(0)] + [\text{HSA1} \cdot \text{CRA1}(0)]$$

The numbers in () indicate which bit in the control register enables the interrupt.

Handshake/interrupt status register bits are cleared by accessing the appropriate port data register. The following table lists the HSR bit and the port data register that must be accessed to clear the bit.

To Clear HSR Bit	Access Register
HSB2	P2DB
HSA2	P2DA
HSB1	P1DB
HSA1	P1DA

Reset clears all handshake/interrupt status register bits to a logic zero.

CDP6823

Register Name:
Handshake Warning Register (HWR)

Register Address:
\$F

Register Bits:

7	6	5	4	3	2	1	0
XX	XX	XX	XX	HWB2	HWA2	HWB1	HWA1

Purpose:

The warning register is a read-only flag register that may be used to determine if a second attempt to set a handshake/interrupt status register bit has been made before the original had been serviced.

Description:

Each bit in the handshake/interrupt status register, except IRQF, has a corresponding bit in the handshake warning register. If an attempt is made to set a bit in the handshake/interrupt status register that is already set, then the corresponding bit in the handshake warning register is also set. An attempt is the occurrence of any enabled input handshake transition as defined by the control registers.

A handshake warning register bit is cleared by first reading the appropriate data register then reading the handshake warning register. Reading the data register (either P1DA, P2DA, P1DB, or P2DB) loads a buffer latch with the proper bit in the handshake warning register (HWA1, HWA2, HWB1, and HWB2, respectively). The next read of the handshake warning register clears the appropriate bit

without affecting the other three handshake warning register bits. The upper four bits, HWR4-HWR7, always read as logic zeros. If a port data register is not read before reading the handshake warning register, then the handshake warning register bits will remain unaffected. Reset clears all HWR bits to a logic zero.

Recommended status register handling sequence:

1. Read status register (User determines which if any enabled handshake transition occurred)
2. Read/write port data indicated by latches appropriate warning status register bit in the buffer latch (Clears associated status bit and latches appropriate warning register bit in the buffer latch)
3. Read warning register (Latched warning bit is cleared and the remaining bits are unaffected)

TYPICAL INTERFACING

The CDP6823 is best suited for use with microprocessors which generate an address-then-data-multiplexed bus. Fig. 9 shows the CDP6823 in a typical CMOS system that uses the CDP6805E2 CMOS MPU. Other multiplexed microprocessors can be used as easily.

A single-chip microcomputer (MCU) may be interfaced with 11 port lines as shown in Fig. 10. This interface also requires some software overhead to gain up to 13 additional I/O lines and the CDP6823 handshake lines.

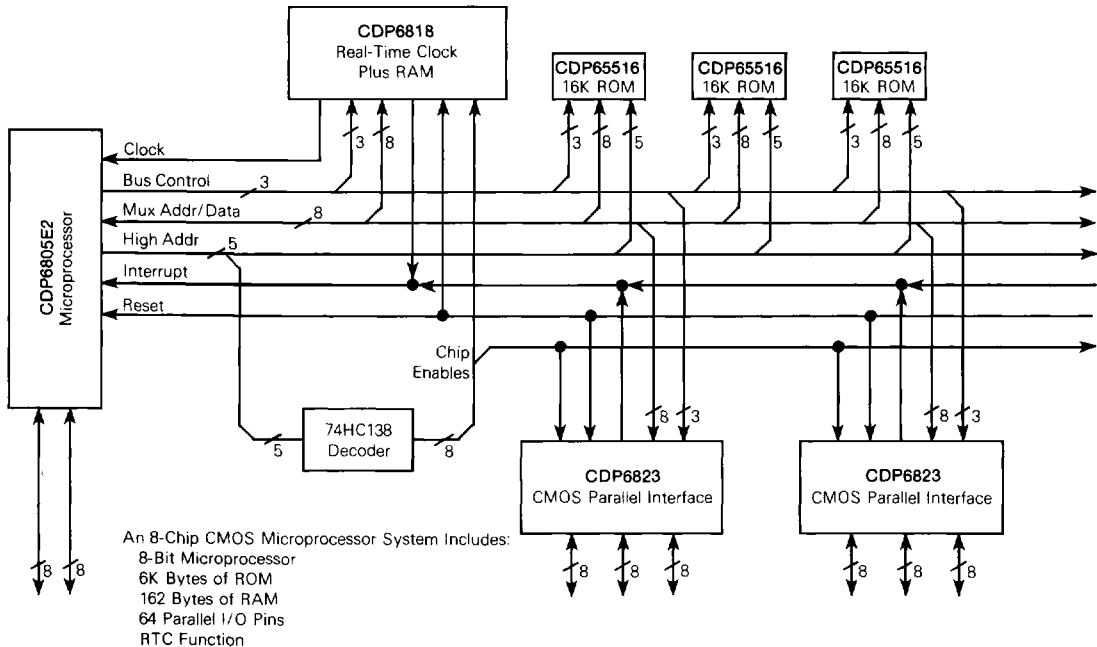

Fig. 9 - A typical CMOS microprocessor system.

CDP6823

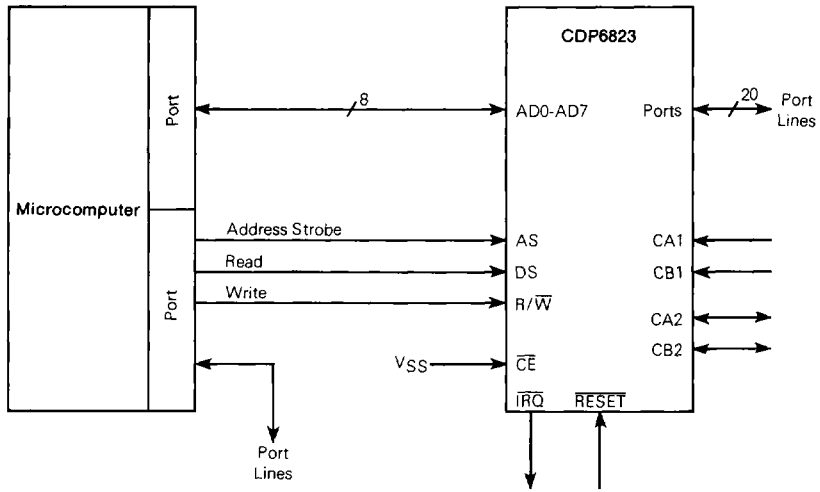

Fig. 10 - CDP6823 interfaced with the ports of a typical single-chip microprocessor.