

100166



Not Intended For New Designs

T-45-17

100166 9-Bit Comparator

General Description

The 100166 is a 9-bit magnitude comparator which compares the arithmetic value of two 9-bit words and indicates whether one word is greater than, or equal to, the other.

Other functions can be generated by the wire-OR of the outputs. All inputs have 50 kΩ pulldown resistors.

Ordering Code: See Section 6

Logic Symbol

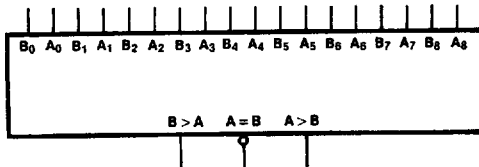

TL/F/9867-3

Pin Names	Description
A ₀ -A ₈	A Data Inputs
B ₀ -B ₈	B Data Inputs
A > B	A Greater than B Output
B > A	B Greater than A Output
A = B	Complement A Equal to B Output (Active LOW)

Connection Diagrams

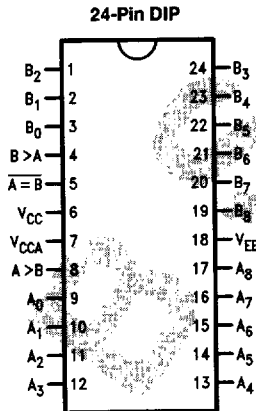

TL/F/9867-1

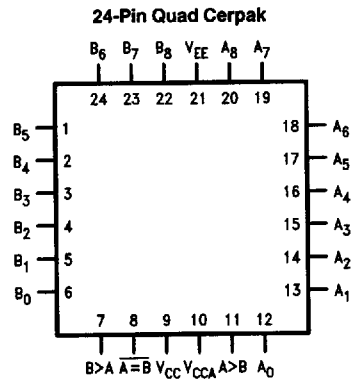

TL/F/9867-2

Logic Diagram

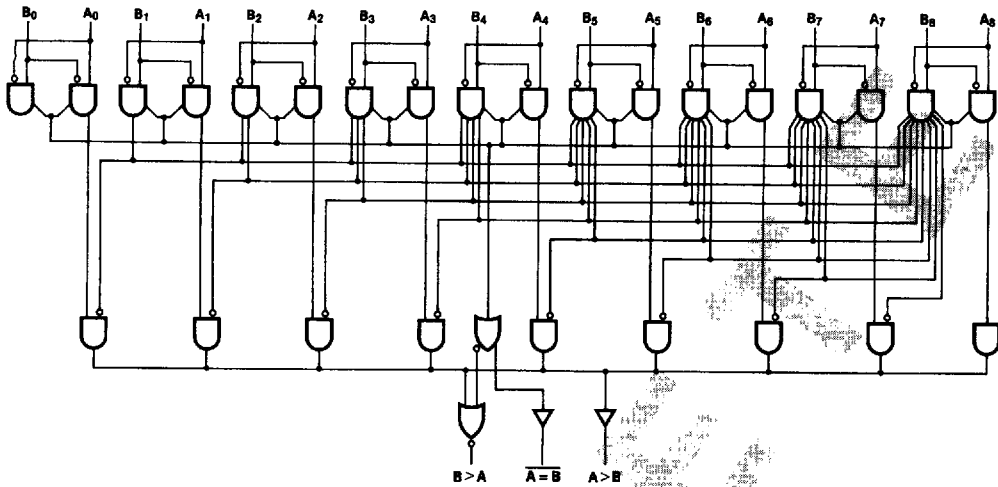

TL/F/9867-5

Truth Table

Inputs									Outputs		
A ₈ B ₈	A ₇ B ₇	A ₆ B ₆	A ₅ B ₅	A ₄ B ₄	A ₃ B ₃	A ₂ B ₂	A ₁ B ₁	A ₀ B ₀	A > B	B > A	A = B
H L									H	L	H
L H									L	H	L
A ₈ = B ₈	H L								H	L	H
A ₈ = B ₈	L H								L	H	L
A ₈ = B ₈		H L							H	L	H
A ₈ = B ₈		L H							L	H	L
A ₈ = B ₈	A ₇ = B ₇	A ₆ = B ₆							H	L	H
A ₈ = B ₈	A ₇ = B ₇	A ₆ = B ₆	H L						L	H	L
A ₈ = B ₈	A ₇ = B ₇	A ₆ = B ₆	L H						H	L	H
A ₈ = B ₈	A ₇ = B ₇	A ₆ = B ₆		H L					L	H	L
A ₈ = B ₈	A ₇ = B ₇	A ₆ = B ₆		L H					H	L	H
A ₈ = B ₈	A ₇ = B ₇	A ₆ = B ₆	A ₅ = B ₅						H	L	H
A ₈ = B ₈	A ₇ = B ₇	A ₆ = B ₆	A ₅ = B ₅	H L					L	H	L
A ₈ = B ₈	A ₇ = B ₇	A ₆ = B ₆	A ₅ = B ₅	L H					H	L	H
A ₈ = B ₈	A ₇ = B ₇	A ₆ = B ₆	A ₅ = B ₅		H L				L	H	L
A ₈ = B ₈	A ₇ = B ₇	A ₆ = B ₆	A ₅ = B ₅		L H				H	L	H
A ₈ = B ₈	A ₇ = B ₇	A ₆ = B ₆	A ₅ = B ₅	A ₄ = B ₄					H	L	H
A ₈ = B ₈	A ₇ = B ₇	A ₆ = B ₆	A ₅ = B ₅	A ₄ = B ₄	A ₃ = B ₃				L	H	L
A ₈ = B ₈	A ₇ = B ₇	A ₆ = B ₆	A ₅ = B ₅	A ₄ = B ₄	A ₃ = B ₃	H L			H	L	H
A ₈ = B ₈	A ₇ = B ₇	A ₆ = B ₆	A ₅ = B ₅	A ₄ = B ₄	A ₃ = B ₃	L H			L	H	L
A ₈ = B ₈	A ₇ = B ₇	A ₆ = B ₆	A ₅ = B ₅	A ₄ = B ₄	A ₃ = B ₃				H	L	H
A ₈ = B ₈	A ₇ = B ₇	A ₆ = B ₆	A ₅ = B ₅	A ₄ = B ₄	A ₃ = B ₃	A ₂ = B ₂			L	H	L
A ₈ = B ₈	A ₇ = B ₇	A ₆ = B ₆	A ₅ = B ₅	A ₄ = B ₄	A ₃ = B ₃	A ₂ = B ₂			H	L	H
A ₈ = B ₈	A ₇ = B ₇	A ₆ = B ₆	A ₅ = B ₅	A ₄ = B ₄	A ₃ = B ₃	A ₂ = B ₂	A ₁ = B ₁		L	H	L
A ₈ = B ₈	A ₇ = B ₇	A ₆ = B ₆	A ₅ = B ₅	A ₄ = B ₄	A ₃ = B ₃	A ₂ = B ₂	A ₁ = B ₁	H L	H	L	H
A ₈ = B ₈	A ₇ = B ₇	A ₆ = B ₆	A ₅ = B ₅	A ₄ = B ₄	A ₃ = B ₃	A ₂ = B ₂	A ₁ = B ₁	L H	L	H	H
A ₈ = B ₈	A ₇ = B ₇	A ₆ = B ₆	A ₅ = B ₅	A ₄ = B ₄	A ₃ = B ₃	A ₂ = B ₂	A ₁ = B ₁	A ₀ = B ₀	L	L	L

H = HIGH Voltage Level
 L = LOW Voltage Level
 Blank = Don't Care

100166

Absolute Maximum Ratings

Above which the useful life may be impaired. (Note 1)

If Military/Aerospace specified devices are required, please contact the National Semiconductor Sales Office/Distributors for availability and specifications.

Storage Temperature -65°C to +150°C
 Maximum Junction Temperature (T_J) +150°C

Case Temperature under Bias (T_C) 0°C to +85°C
 V_{EE} Pin Potential to Ground Pin -7.0V to +0.5V
 Input Voltage (DC) V_{EE} to +0.5V
 Output Current (DC Output HIGH) -50 mA
 Operating Range (Note 2) -5.0V to -4.2V

DC Electrical Characteristics

V_{EE} = -4.5V, V_{CC} = V_{CCA} = GND, T_C = 0°C to +85°C (Note 3)

Symbol	Parameter	Min	Typ	Max	Units	Conditions (Note 4)	
V _{OH}	Output HIGH Voltage	-1025	-955	-880	mV	V _{IN} = V _{IH} (Max) or V _{IL} (Min)	Loading with 50Ω to -2.0V
V _{OL}	Output LOW Voltage	-1810	-1705	-1620			
V _{OHc}	Output HIGH Voltage	-1035			mV	V _{IN} = V _{IH} (Min) or V _{IL} (Max)	Loading with 50Ω to -2.0V
V _{OLc}	Output LOW Voltage			-1610			
V _{IH}	Input HIGH Voltage	-1165		-880	mV	Guaranteed HIGH Signal for All Inputs	
V _{IL}	Input LOW Voltage	-1810		-1475	mV	Guaranteed LOW Signal for All Inputs	
I _{IL}	Input LOW Current	0.50			μA	V _{IN} = V _{IL} (Min)	

DC Electrical Characteristics

V_{EE} = -4.2V, V_{CC} = V_{CCA} = GND, T_C = 0°C to +85°C (Note 3)

Symbol	Parameter	Min	Typ	Max	Units	Conditions (Note 4)	
V _{OH}	Output HIGH Voltage	-1020		-870	mV	V _{IN} = V _{IH} (Max) or V _{IL} (Min)	Loading with 50Ω to -2.0V
V _{OL}	Output LOW Voltage	-1810		-1605			
V _{OHc}	Output HIGH Voltage	-1030			mV	V _{IN} = V _{IH} (Min) or V _{IL} (Max)	Loading with 50Ω to -2.0V
V _{OLc}	Output LOW Voltage			-1595			
V _{IH}	Input HIGH Voltage	-1150		-870	mV	Guaranteed HIGH Signal for All Inputs	
V _{IL}	Input LOW Voltage	-1810		-1475	mV	Guaranteed LOW Signal for All Inputs	
I _{IL}	Input LOW Current	0.50			μA	V _{IN} = V _{IL} (Min)	

DC Electrical Characteristics

V_{EE} = -4.8V, V_{CC} = V_{CCA} = GND, T_C = 0°C to +85°C (Note 3)

Symbol	Parameter	Min	Typ	Max	Units	Conditions (Note 4)	
V _{OH}	Output HIGH Voltage	-1035		-880	mV	V _{IN} = V _{IH} (Max) or V _{IL} (Min)	Loading with 50Ω to -2.0V
V _{OL}	Output LOW Voltage	-1830		-1620			
V _{OHc}	Output HIGH Voltage	-1045			mV	V _{IN} = V _{IH} (Min) or V _{IL} (Max)	Loading with 50Ω to -2.0V
V _{OLc}	Output LOW Voltage			-1610			
V _{IH}	Input HIGH Voltage	-1165		-880	mV	Guaranteed HIGH Signal for All Inputs	
V _{IL}	Input LOW Voltage	-1830		-1490	mV	Guaranteed LOW Signal for All Inputs	
I _{IL}	Input LOW Current	0.50			μA	V _{IN} = V _{IL} (Min)	

Note 1: Absolute maximum ratings are those values beyond which the device may be damaged or have its useful life impaired. Functional operation under these conditions is not implied.

Note 2: Parametric values specified at -4.2V to -4.8V

Note 3: The specified limits represent the "worst case" value for the parameter. Since these "worst case" values normally occur at the temperature extremes, additional noise immunity and guard banding can be achieved by decreasing the allowable system operating ranges.

Note 4: Conditions for testing shown in the tables are chosen to guarantee operation under "worst case" conditions.

DC Electrical Characteristics

$V_{EE} = -4.2V$ to $-4.8V$ unless otherwise specified, $V_{CC} = V_{CCA} = GND$, $T_C = 0^\circ C$ to $+85^\circ C$

Symbol	Parameter	Min	Typ	Max	Units	Conditions
I_{IH}	Input HIGH Current All Inputs			250	μA	$V_{IN} = V_{IH} (Max)$
I_{EE}	Power Supply Current	-238	-170	-119	mA	Inputs Open

Ceramic Dual-In-Line Package AC Electrical Characteristics

$V_{EE} = -4.2V$ to $-4.8V$, $V_{CC} = V_{CCA} = GND$

Symbol	Parameter	$T_C = 0^\circ C$		$T_C = +25^\circ C$		$T_C = +85^\circ C$		Units	Conditions
		Min	Max	Min	Max	Min	Max		
t_{PLH} t_{PHL}	Propagation Delay Data to Output	1.40	3.50	1.40	3.50	1.40	3.90	ns	Figures 1 and 2
t_{TLH} t_{THL}	Transition Time 20% to 80%, 80% to 20%	0.45	1.55	0.45	1.50	0.45	1.50	ns	

Cerpak AC Electrical Characteristics

$V_{EE} = -4.2V$ to $-4.8V$, $V_{CC} = V_{CCA} = GND$

Symbol	Parameter	$T_C = 0^\circ C$		$T_C = +25^\circ C$		$T_C = +85^\circ C$		Units	Conditions
		Min	Max	Min	Max	Min	Max		
t_{PLH} t_{PHL}	Propagation Delay Data to Output	1.40	3.30	1.40	3.30	1.40	3.70	ns	Figures 1 and 2
t_{TLH} t_{THL}	Transition Time 20% to 80%, 80% to 20%	0.45	1.45	0.45	1.40	0.45	1.40	ns	

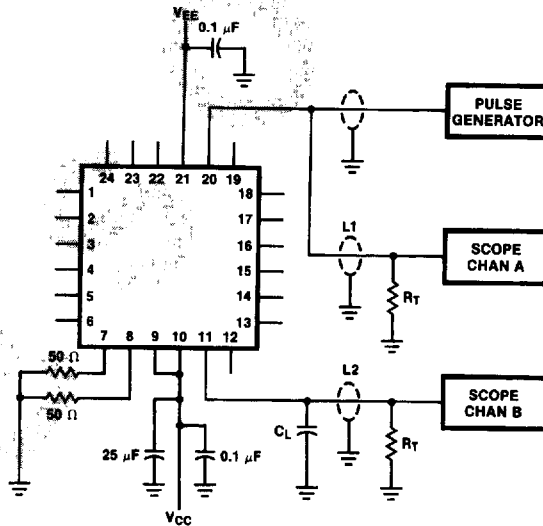

FIGURE 1. AC Test Circuit

TL/F/9867-6

- Notes:**
 $V_{CC}, V_{CCA} = +2V$, $V_{EE} = -2.5V$
 L1 and L2 = equal length 50Ω impedance lines
 $R_T = 50\Omega$ terminator internal to scope
 Decoupling 0.1 μF from GND to V_{CC} and V_{EE}
 All unused outputs are loaded with 50Ω to GND
 C_L = Fixture and stray capacitance ≤ 3 pF
 Pin numbers shown are for flatpak, for DIP see logic symbol

100166

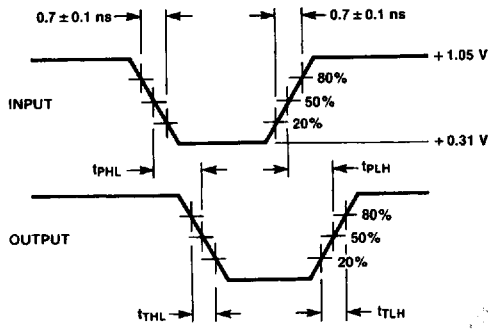

FIGURE 2. Propagation Delay and Transition Times

TL/F/9867-7