

Gate Driver Unit 2QG010DDC11N

■ Overview

2QG010DDC11N is a dual channel gate driver designed for Fuji Electric's IGBT power module 2MBI1800XXG170-50 .

This gate driver unit contains a built-in isolated DC/DC converter and gate drive circuit. It is ready to use by mounting it on the IGBT power module.

■ Features

- Ideal for drive of IGBT Power module 2MBI1800XXG170-50(Fuji Electric)
- Gate voltage : +15V/-10V
- Gate resistor : +0.22Ω/-1.5Ω(TYP)
- Short circuit detection voltage : 9.5V(TYP)
- ALL-IN-ONE (Built-in isolated DC / DC converter and gate drive circuit)
- Low parasitic capacitance (12pF(TYP)) ; highly resistant to common-mode noise.
- Fast response : About 130nsec(typ)
- The isolation for primary-secondary signal used fast response isolator.
- Dielectric withstand voltage : AC5000V
- Insulation distance (clearance / creepage) : 14mm/16mm (As for Gate driver PCB)
- DC/DC converter input voltage : 13~28V
- Power supply for gate driver input voltage : 13~28V
- Signal input voltage : 15V
- The DC / DC converter has built-in overheat protection and overload protection.
- Desaturation protection (Gate drive circuit)
- Soft turn-off function (Gate drive circuit)
- Fault signal output function (Gate drive circuit)
- Under-voltage lockout(UVLO) (Gate drive circuit)
- Direct mode / Half bridge mode can be switched. (Gate drive circuit)
- Active clamp protection function (Gate drive circuit)
- Safety standards : UL508(file no.E243511) (DC/DC converter only)
- Reinforced isolation according to IEC 60664-1 (IEC61800-5-1, IEC62477-1, IEC62109-1, etc.)
- UL compliant (UL1741, UL508, etc.)
- Insulating moistureproof coating

■ Application

Industrial inverter, power conditioner, etc. ...

■ Module information

Part number	Part number (Uncoated)	Signal input voltage	Active clamp	Status
2QG010DDC11N	2QG010DDN11N	15V	Yes	Active

*Uncoated type is sample only

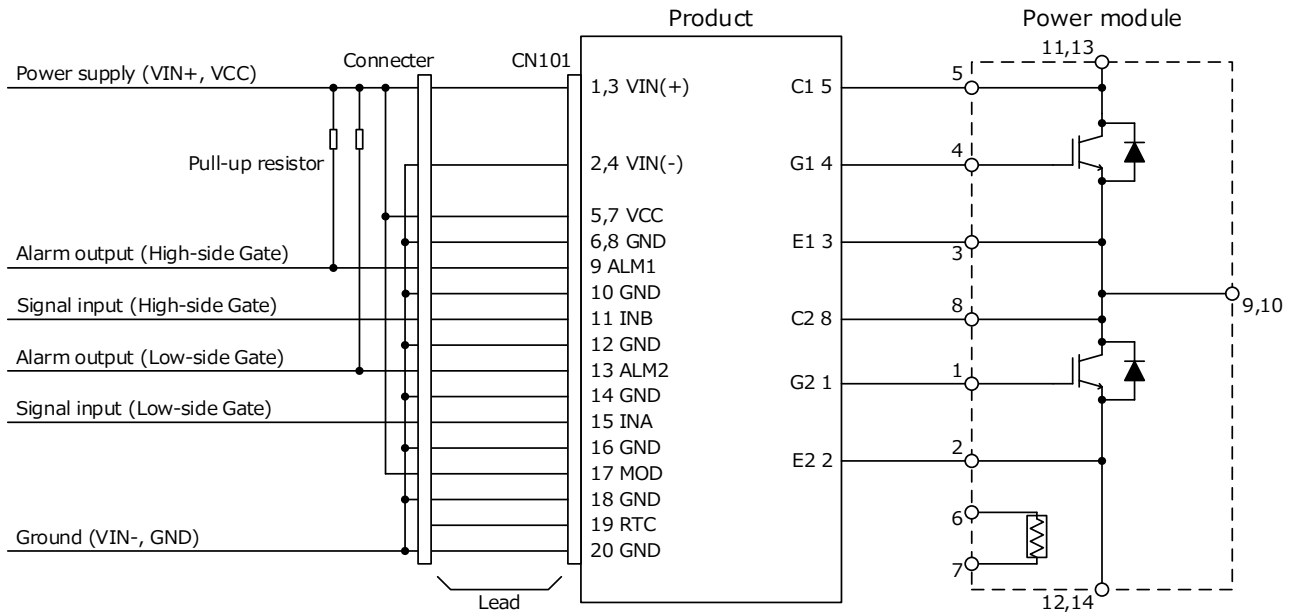
■ Circuit Image

■ Pin Connection

CN101 : RA-H201SD (JST)

Pin No.	Name	Function	Pin No.	Name	Function
1	VIN(+)	Power supply for DC/DC converter(+)	2	VIN(-)	Power supply for DC/DC converter(-)
3	VIN(+)	Power supply for DC/DC converter(+)	4	VIN(-)	Power supply for DC/DC converter(-)
5	VCC	Power supply for drive circuit	6	GND	Ground for drive circuit
7	VCC	Power supply for drive circuit	8	GND	Ground for drive circuit
9	ALM1	Alarm signal output 1 (High side)	10	GND	Ground for drive circuit
11	INB	Control input B (High side)	12	GND	Ground for drive circuit
13	ALM2	Alarm signal output 2 (Low side)	14	GND	Ground for drive circuit
15	INA	Control input A (Low side)	16	GND	Ground for drive circuit
17	MOD	Mode select	18	GND	Ground for drive circuit
19	RTC	Recovery time of protection circuit control	20	GND	Ground for drive circuit

※Reference receptacle : RA-S201T (JST)

Connection on the power module

Pin No.	Name	CH	Function
1	G2	2(L)	Gate connection, Low side
2	E2	2(L)	Emitter connection, Low side
3	E1	1(H)	Emitter connection, High side
4	G1	1(H)	Gate connection, High side
5	C1	1(H)	Collector connection, High side
8	C2	2(L)	Collector connection, Low side

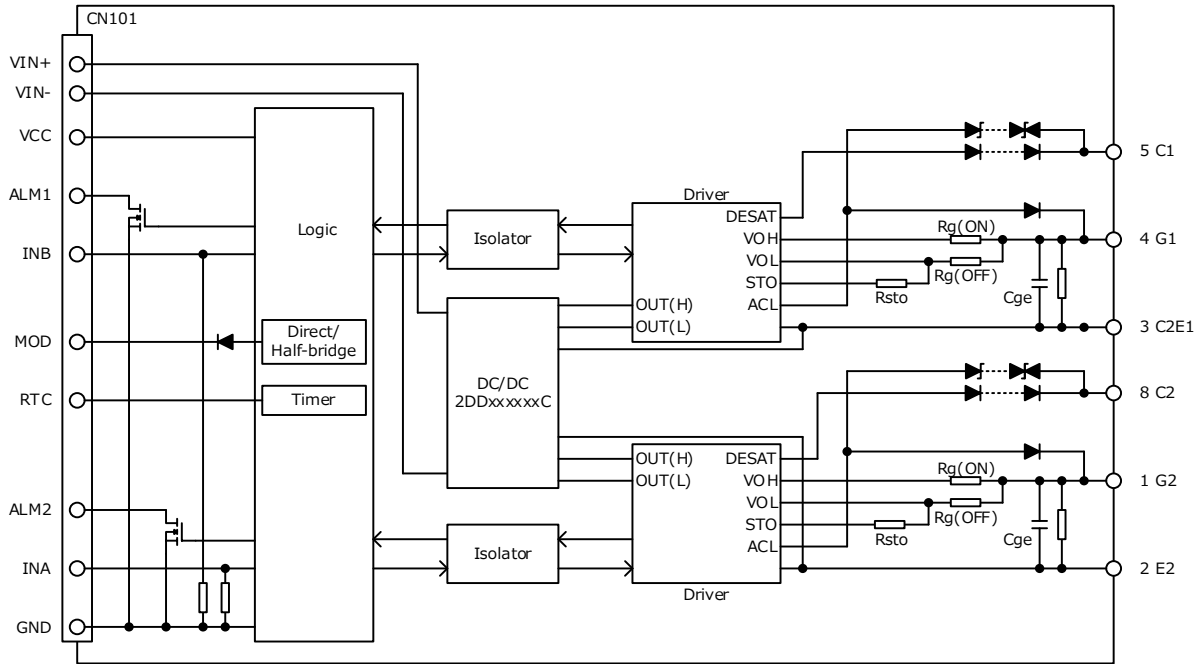
Internal Block Diagram

I/O Condition Table

No.	Status	Input						Output				
		OUT(H)	C1(H)	C2(L)	MOD	INB	INA	ALM1	ALM2	G1(H)	G2(L)	
1	V _{OUT} UVLO	UVLO	X	X	X	X	X	L	L	L	L	
2	G-E short	○	X	X	X	X	X	L	L	SD	SD	
3	Normal operation	○	-	L	H	-	L	-	Hi-Z	-	L	
4		○	-	L	H	-	H	-	Hi-Z	-	H	
5		○	L	-	H	L	-	Hi-Z	-	L	-	
6		○	L	-	H	H	-	Hi-Z	-	H	-	
7		○	L	L	L	L	X	Hi-Z	Hi-Z	L	L	
8		○	L	L	L	H	L	Hi-Z	Hi-Z	H	L	
9		○	L	L	L	H	H	Hi-Z	Hi-Z	L	H	
10		Short circuit detection (L)	○	-	Hi-Z	H	-	L	-	Hi-Z	-	L
11			○	-	Hi-Z	H	-	H	-	L	-	L
12	○		-	Hi-Z	L	H	L	-	Hi-Z	-	L	
13	Short circuit detection (H)	○	-	Hi-Z	L	H	H	-	L	-	L	
14		○	Hi-Z	-	H	L	-	Hi-Z	-	L	-	
15		○	Hi-Z	-	H	H	-	L	-	L	-	
16		○	Hi-Z	-	L	H	H	Hi-Z	-	L	-	
17		○	Hi-Z	-	L	H	L	L	-	L	-	

G-E short : Gate-Emitter short

○ : OUT(H) > UVLO, X : Don't care

SD : Shut down (Gate-Emitter short)

■ Absolute Maximum Ratings

Item	Symbol	Min	Max	Unit	Conditions · Note	
Input voltage for DC/DC converter	V_{IN}	-0.3	28	Vdc	Between VIN(+) to VIN(-)	
Input voltage for Gate driver	V_{CC}	-0.3	28	Vdc	Between VCC to GND	
Input-side signal voltage	V_{SG}	-0.3	$V_{CC}+0.3$ or 18 *	V	INA, INB *Whichever is less	
	V_{MOD}	-0.3	28	V	MOD	
	V_{RTC}	-0.3	5	V	RTC	
Maximum gate current	I_{GPEAK}	-	43	A	Excluding gate resistor	
Switching frequency	F_{SW}	-	20	kHz	See the permissible frequency curve	
Short circuit detection pin voltage	V_{SD}	0	1700	V		
Alarm signal output pin maximum voltage	V_{ALM}	-0.3	$V_{CC}+0.3$ or 28 *	V	ALM1,2 *Whichever is less	
Input-side signal maximum current	I_{ALM}	-	5	mA	ALM1,2	
Operating temperature range	$V_{IN}=13.5-18V$	T_{OP}	-40	85	°C	See the permissible frequency curve
	$V_{IN}=18-26.4V$	T_{OP}	-40	75	°C	
Operating humidity	RH_{OP}	20	95	%RH	No condensation	
Storage temperature range	T_{STG}	-40	90	°C		
Storage humidity	RH_{STG}	5	95	%RH	No condensation	

■ Recommended Operating Conditions

Item	Symbol	Min	Max	Unit	Conditions · Note
Input voltage range for DC/DC converter	V_{IN}	13.5	26.4	Vdc	
Input voltage range for gate driver	V_{CC}	13.5	26.4	Vdc	
Driver circuit number	N	-	2	-	
Maximum gate charge	Q_G	-	14000	nC	*1
Switching frequency ($Q_g=12500nC$)	F_{SW}	-	8.8	kHz	See the permissible frequency curve
MOD pin high input voltage	V_{MODH}	3.3	26.4	V	
MOD pin low input voltage	V_{MODL}	-0.3	0.5	V	
Logic high level input voltage	V_{SGH}	13	$V_{CC}+0.3$ or 16 *	V	INA, INB *Whichever is less
Logic low level input voltage	V_{SGL}	-0.3	0.5	V	INA, INB
Source current of control signal	I_{SG}	3.3	-	mA	INA, INB $V_{SG}=15V$
For 2QGxxxDxx11N(Active clamp model)					
DC-link voltage	$V_{DC-LINK}$	-	1100	V	*2

*1 If the gate charge exceeds the allowable value, the gate voltage at turn-on and turn-off will drop, which may affect the switching performance of the IGBT.

If you are considering using it under conditions other than the recommended conditions, please contact us.

*2 Use below the recommended DC link voltage.

If you are considering using it under conditions other than the recommended conditions, please contact us.

■ Permissible frequency curve

Internal gate resistor of IGBT = 2.08Ω

*The permissible frequency curve changes with the ratio of the IGBT internal gate resistance to the gate resistance.

Therefore, as the internal resistance of the IGBT decreases, the allowable frequency also decreases.

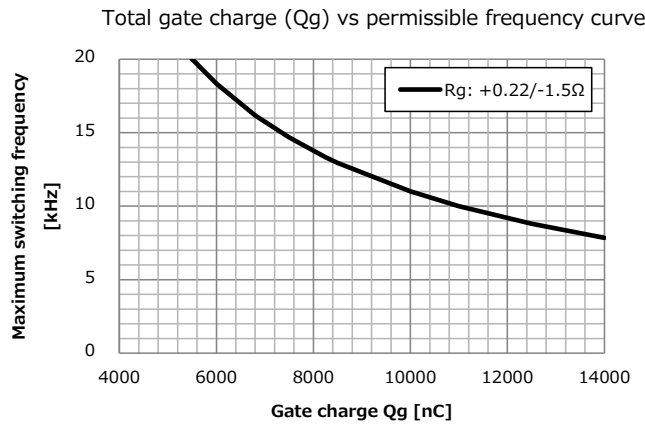

Ta: -40~+85°C / VIN = 13.5~18V

Ta: -40~+75°C / VIN = 18~26.4V

■ Electrical Specification (Vin=Vcc=15V, Ta=25°C, Unless otherwise specified)

Item	Symbol	Min	Typ	Max	Unit	Conditions · Note	
DC/DC converter							
Start-up voltage	V _{START}	-	11.5	12.5	V		
Input current	I _{IN}	-	0.5	-	A	Fsw=8.8kHz, Test load : 2.15Ω/500nF	
		-	0.5	-		Fsw=10kHz, Test load : 2.15Ω/440nF	
Standby power	P _{STBY}	-	1.3	-	W	No load	
Logic inputs							
Logic high level input voltage	V _{SGH}	-	10.4	11.4	V	INA, INB /Guaranteed by design	
Logic low level input voltage	V _{SGL}	4.9	5.9	-	V	INA, INB /Guaranteed by design	
Logic pull-down resistance	R _{SGD}	-	4500	-	Ω	INA, INB	
Gate driver output							
Output pin voltage(High)	V _{OUTH}	14	15	16	V	No load	
Output pin voltage(Low)	V _{OUTL}	-11	-10	-9	V	No load	
Gate resistor	Rg(ON)	-	0.22	-	Ω		
	Rg(OFF)	-	1.5	-			
Auxiliary gate capacitor	Cge	-	OPEN	-	nF		
Delay time	Turn ON time	t _{PON}	-	130	-	ns	
	Turn OFF time	t _{POFF}	-	130	-	ns	
Dead time	t _{DEAD}	-	3	-	us	Half bridge mode	

■ Protection

Item	Symbol	Min	Typ	Max	Unit	Conditions · Note
DC/DC converter						
Overload protection	-	10.5	-	-	W	Auto recovery
Overheat protection	-	120	-	150	°C	Auto recovery, Internal temperature
Gate driver						
Output voltage(H) UVLO OFF voltage	V _{UVLOOFFH}	13.2	13.5	13.8	V	Guaranteed by design
Output voltage(H) UVLO ON voltage	V _{UVLOONH}	12.2	12.5	12.8	V	Guaranteed by design
Short circuit detection voltage	V _{SD}	-	9.5	-	V	
Short circuit detection filter time	t _{SHORTFIL}	-	4.5	-	us	Collector open
Alarm signal output L voltage	V _{ALML}	-	-	0.5	V	I _{ALM} =5mA
Alarm signal output time	t _{ALM}	-	0.2	-	us	
Restart time	t _{RESTART}	-	110	-	ms	
Soft turn-off resistance	R _{STO}	-	12	-	Ω	
Soft turn-off duration	t _{STO}	-	4	-	us	

■ Insulation

Item	Specification	Conditions · Note
Between Input-Output		
Dielectric withstand voltage	AC5000V	1min, Cutoff 2mA
Insulation resistance	100MΩ or more	DC500V
Partial discharge extinction voltage	1768V _{peak} or more	According to EN50178/IEC 60270
Common-mode transient immunity (CMTI)	70kV/us	
Minimum clearance distances	14mm	As for Gate driver PCB
Minimum creepage distances	16mm	
Between CH1-CH2		
Minimum clearance distances	8mm	
Minimum creepage distances	12mm	

■ Storage Conditions

Item	Min	Max	Unit	Conditions · Note
Storage temperature	-25	60	°C	A packing state

■ Usage Cautions

- Always mount fuse on the plus side of input for ensuring safety because the fuse is not built-in the product.
Please select the fuse considering conditions such as steady current, inrush current, and ambient temperature.
When using a fuse having large rated current or high capacity input electrolytic condenser, by combining another converter and input line and input electrolytic condenser, fuse may not blow off in the case of abnormality.
Do not combine high voltage line and fuse.

- Make sure the rise/fall time of the input signal is 500ns or less.
Also, keep input wiring as far as possible from noise sources.
To prevent malfunction due to noise, we recommend the highest possible signal voltage within the recommended range.

- Please do not apply excessive stress to this product when attaching to IGBT power module.
Please follow the device manufacturer's instructions on how to install the IGBT power module (type of screw used, material, tightening torque conditions, etc.).
Also, if the product is exposed to vibration or shock, the PCB should be fixed with spacers as shown in the figure below.
The screw header / washer diameter uses the following.
 - M3 (Printed circuit board fixed) : 7mm or less
 - M4 (Connection on the power module) : 9mm or less

*To maintain the reliability of parts near the metal terminal pad, the screw header including the washer must not exceed the available metal terminal pad of the gate driver.

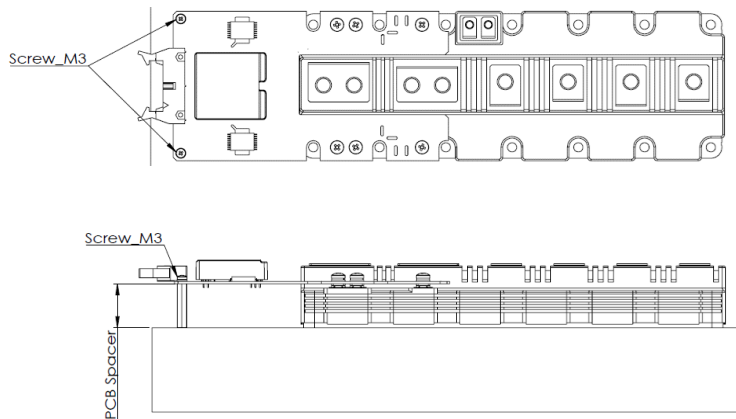

- This product has DESAT protection for arm short circuit and load short circuit protection.
However, even if this protection works, the IGBT may be damaged if abnormally high current occurs due to IGBT's characteristics variations or the load short-circuit mode during parallel operation.
To ensure safety, be sure to check the short-circuit current at the unit in which this product is integrated, and evaluate whether it can protect under the condition that there is no damage to the IGBT.

- The coating material is applied to the product, so it may appear to be partially whitened.
This does not affect the characteristics of the product.

■ Outline Dimensional Drawing

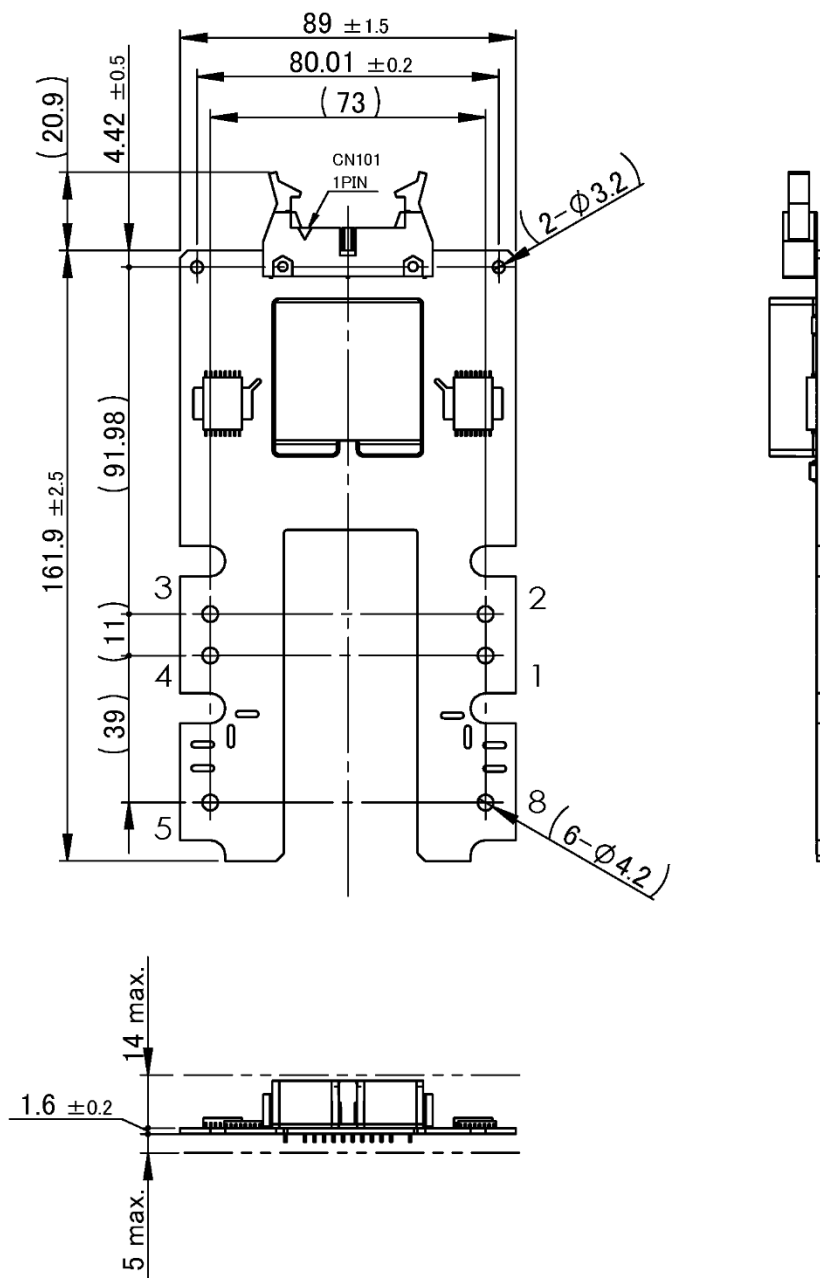

Unit: mm

Note: 1. The dimensional tolerance without directions is ± 0.5 mm.

■ Product Weight

78.0g(typ)

■ Important Notice

- This information and product are subject to change without prior notice for the purpose of improvements, etc. Ensure that you are in possession of the most up-to-date information when using this product.
- The operation examples and circuit examples shown in this document are for reference purposes only, and TAMURA Corporation disclaims all responsibility for any violations of industrial property rights, intellectual property rights and any other rights owned by TAMURA Corporation or third parties that these may entail.
- The circuit examples and part constants listed in this document are provided as reference for the verification of characteristics. You are to perform design, verification, and judgment at your own responsibility, taking into account the various conditions.
- TAMURA has evaluated the efficiency and performance of this product in a usage environment determined by us. Depending on your usage environment or usage method, there is the possibility that this product will not perform sufficiently as shown in the specifications, or may malfunction.
When applying this product to your devices or systems, please ensure that you conduct evaluations of their state when integrated with this product. You are responsible for judging its applicability.
TAMURA bears no responsibility whatsoever for any problems with your devices, systems or this product which are caused by your usage environment or usage method.
- TAMURA Corporation constantly strives to improve quality and reliability, but malfunction or failures are bound to occur with some probability in power products. To ensure that failures do not cause accidents resulting in injury or death, fire accidents, social damage, and so on, you are to thoroughly verify the safety of their designs in devices and/or systems, at your own responsibility.
- This product is intended for use in consumer electronics (electric home appliances, business equipment, Information equipment, communication terminal equipment, measuring devices, and so on.) If considering use of this product in equipment or devices that require high reliability (medical devices, transportation equipment, traffic signal control equipment, fire and crime prevention equipment, aeronautics and space devices, nuclear power control, fuel control, in-vehicle equipment, safety devices, and so on), please consult a TAMURA sales representative in advance. Do not use this product for such applications without written permission from TAMURA Corporation.
- This product is intended for use in environments where consumer electronics are commonly used. It is not designed for use in special environments such as listed below, and if such use is considered, you are to perform thorough safety and reliability checks at your own responsibility.
 - Use in liquids such as water, oil, chemical solutions, or organic solvents, and use in locations where the product will be exposed to such liquids.
 - Use that involves exposure to direct sunlight, outdoor exposure, or dusty conditions.
 - Use in locations where corrosive gases such as salt air, C12, H2S, NH3, SO2, or NO2, are present.
 - Use in environments with strong static electricity or electromagnetic radiation.
 - Use that involves placing inflammable material next to the product.
 - Use of this product either sealed with a resin filling or coated with resin.
 - Use of water or a water soluble detergent for flux cleaning.
 - Use in locations where condensation is liable to occur.
- This product is not designed to resist radiation.
- This product is not designed to be connected in series or parallel.
Do not operate this product in a series, parallel, or N+1 redundant configuration.
- Do not use or otherwise make available the TAMURA products or the technology described in this document for any military purposes, including without limitation, for the design, development, use, stockpiling or manufacturing of mass destruction weapons (e.g. nuclear, chemical, or biological weapons or missile technology products).
When exporting and re-exporting the products or technology described in this document, you should comply with the applicable export control laws and regulations and follow the procedures required by such laws and regulations including, without limitation, Japan -Foreign Exchange and Foreign Trade Control Law and U.S.- Export Administration Regulations.
The TAMURA products and related technology should not be used for or incorporated into any products or systems whose manufacture, use, or sale is prohibited under any applicable domestic or foreign laws or regulations.
- Please contact your TAMURA sales office for details as to environmental matters such as the RoHS compatibility of product.
Please use TAMURA products in compliance with all applicable laws and regulations that regulate the inclusion or use of controlled substances, including without limitation, the EU RoHS Directive.
TAMURA assumes no liability for damages or losses occurring as a result of your noncompliance with applicable laws and regulations.
- TAMURA assumes no liability for damages or losses incurred by you or third parties as a result of unauthorized use of TAMURA products.
- This document and any information herein may not be reproduced in whole or in part without prior written permission from TAMURA.