



SANYO Semiconductors

DATA SHEET

STK621-728-E

Thick-Film Hybrid IC
— 3-phase Inverter Motor Drive
Inverter Hybrid IC

Overview

The STK621-728-E is an inverter power hybrid IC for use in 3-phase fan-motor applications and contains power stage, pre-driver, and protection circuits.

Applications

- 3-phase inverter motor drive for air conditioners, washing machines, etc.

Features

- Protective circuits including overcurrent (bus line), and pre-drive low voltage protection are built in.
- Direct input of CMOS level control signals without an insulating circuit is possible.(Hi Active).
- Single power supply drive is possible through the use of a built-in upper-side power-supply bootstrap circuit (Needs external capacitors).
- Built-in simultaneous upper/lower ON prevention circuit to prevent arm shorting through simultaneous ON input for the upper and lower side transistors. (Dead time is required for preventing shorting due to switching delay.)
- The current level for overcurrent protection can be adjusted by connecting an external resistor R_{SD} between the I_{SD} and V_{SS} terminals.
- The built-in thermistor allows substrate temperature to be monitored.

■ Any and all SANYO Semiconductor Co.,Ltd. products described or contained herein are, with regard to "standard application", intended for the use as general electronics equipment (home appliances, AV equipment, communication device, office equipment, industrial equipment etc.). The products mentioned herein shall not be intended for use for any "special application" (medical equipment whose purpose is to sustain life, aerospace instrument, nuclear control device, burning appliances, transportation machine, traffic signal system, safety equipment etc.) that shall require extremely high level of reliability and can directly threaten human lives in case of failure or malfunction of the product or may cause harm to human bodies, nor shall they grant any guarantee thereof. If you should intend to use our products for applications outside the standard applications of our customer who is considering such use and/or outside the scope of our intended standard applications, please consult with us prior to the intended use. If there is no consultation or inquiry before the intended use, our customer shall be solely responsible for the use.

■ Specifications of any and all SANYO Semiconductor Co.,Ltd. products described or contained herein stipulate the performance, characteristics, and functions of the described products in the independent state, and are not guarantees of the performance, characteristics, and functions of the described products as mounted in the customer's products or equipment. To verify symptoms and states that cannot be evaluated in an independent device, the customer should always evaluate and test devices mounted in the customer's products or equipment.

STK621-728-E

Specifications

Absolute Maximum Ratings at $T_c = 25^\circ\text{C}$

Parameter	Symbol	Conditions	Ratings	unit
Supply voltage	V_{CC}	+ - - terminal, surge < 500V *1	450	V
Collector-emitter voltage	V_{CE}	+ - U (V, W) terminal or U (V, W) - - terminal	600	V
Output current	I_O	+, -, U, V, W terminal current	± 10	A
Output peak current	I_{op}	+, -, U, V, W terminal current P.W. = 100 μ s	± 20	A
Pre-driver supply voltage	VD1, 2, 3, 4	VB1 - U, VB2 - V, VB3 - W, $V_{DD} - V_{SS}$ terminal *2	20	V
Input signal voltage	V_{IN}	HIN1, 2, 3, LIN1, 2, 3 terminal	0 to 15	V
FAULT terminal voltage	VFAULT	FAULT terminal	20	V
Maximum loss	P_d	IGBT, Per 1 channel	31.2	W
Junction temperature	T_j	IGBT, FRD junction temperature	150	$^\circ\text{C}$
Storage temperature	T_{stg}		-40 to +125	$^\circ\text{C}$
Operating temperature	T_c	H-IC case temperature	-20 to +100	$^\circ\text{C}$
Tightening torque	MT	A screw part *3	1.0	N•m
Withstand voltage	Vis	50Hz sine wave AC 1 minute *4	2000	VRMS

In the case without the instruction, the voltage standard is - terminal = V_{SS} terminal voltage.

*1 Surge voltage developed by the switching operation due to the wiring inductance between the + and - terminals.

*2 VD1 = between VB1-U, VD2 = VB2-V, VD3 = VB3-W, VD4 = $V_{DD} - V_{SS}$, terminal voltage.

*3 Flatness of the heat-sink should be lower than 0.15mm.

*4 The test condition is AC 2500V, 1 second.

Electrical Characteristics at $T_c=25^\circ\text{C}$, $V_D=15\text{V}$

Parameter	Symbol	Conditions	min	typ	max	unit
Power output part						
Collector-to-emitter cut-off current	I_{CE}	$V_{CE} = 600\text{V}$			0.1	mA
Boot-strap diode reverse current	I_R (BD)	V_R (BD) = 600V			0.1	mA
Collector-to-emitter saturation voltage	V_{CE} (sat)	$I_O = 10\text{A}$ Upper side		1.9	2.6	V
		$I_O = 10\text{A}$ Lower side		2.2	2.9	
Diode forward voltage	V_F	$I_O = -10\text{A}$ Upper side		1.4	2.1	V
		$I_O = -10\text{A}$ Lower side		1.7	2.4	
Junction-to-substrate thermal resistance	θ_{j-c} (T)	IGBT			4	$^\circ\text{C}/\text{W}$
	θ_{j-c} (D)	FWD			6	$^\circ\text{C}/\text{W}$
Control (Pre-driver) part						
Pre-drive power supply consumption electric current	I_D	VD1, 2, 3 = 15V		0.07	0.4	mA
		VD4 = 15V		1.6	4	
Input ON threshold voltage	V_{in} (on)	HIN1, HIN2, HIN3, LIN1, LIN2,	1.5	2.1	2.5	V
Input OFF threshold voltage	V_{in} (off)	LIN3- V_{SS} terminal	0.8	1.3	1.5	V
Input threshold voltage hysteresis *1	V_{in} (hys)		(0.5)	(0.8)		V
FAULT terminal input electric current	IOSD	During fault operations (low) $V_{FAULT} = 0.1\text{V}$		2		mA
FAULT clearness delay time	FLTCLR	After each protection operation ending/RCIN open	18		80	ms
Board Temperature Mounting resistance	R_t	Resistance between the TH (29) and V_{SS} (26) terminals	90	100	110	$\text{k}\Omega$
Protection part						
Over-current protection electric current	ISD	P.W. = 100 μ s, $R_{DS} = 0\Omega$	18.1		22.9	A
Pre-drive low voltage protection	UVLO		10		12	V
Switching time	tON	$I_O = 10\text{A}$, Inductive load	0.3	0.6	1.3	μ s
	tOFF			0.8	1.5	
Electric current output signal level	ISO	$I_O = 10\text{A}$	0.31	0.33	0.35	V
Reverse bias safe operating area	RBSOA	$I_O = 20\text{A}$, $V_{CE} = 450\text{V}$	Full Square			
Short circuit safe operating area	SCSOA	$V_{CE} = 200\text{V}$	4			μ s
Allowable offset voltage slew rate	dv/dt	U (V, W) - - terminal	-50		50	V/ns

In the case without the instruction, the voltage standard is - terminal = V_{SS} terminal voltage.

Notes

1. Input ON voltage turns on output stage and input OFF voltage turns off output stage.
 Apply voltage V_{inH} (max) to 15V to the V_{IN} (ON) pin to turn output stage on, and apply voltage 0V to V_{inH} (min) to the V_{IN} (OFF) pin to turn output stage off.
 *1 : "Input threshold voltage hysteresis" indicates a reference value based on the design value of built-in pre-driver IC.
2. When the internal protection circuit operates, there is a Fault signal ON (When the Fault terminal is low level, Fault signal is ON state : output form is open DRAIN) but the Fault signal doesn't latch.
 After protection operation ends, it returns automatically within about 18ms and resumes operation beginning condition. So, after Fault signal detection, set OFF (Low) to all input signals at once.
 However, the operation of pre-drive power supply low voltage protection (UVLO: it has a hysteresis about 0.2V) is as follows.
 Upper side → There is no FAULT signal output, but it does a corresponding gate signal OFF.
 Incidentally, it returns to the regular operation when recovering to the normal voltage, but the latch continues among input signal ON (High).
 Lower side → It outputs FAULT signal with gate signal OFF.
 However, it is different from the protection operation of upper side, it automatically resets about 18ms later and resumes operation beginning condition when recovering to normal voltage.
 (The protection operation doesn't latch by the input signal.)
3. When assembling the hybrid IC on the heat sink, tightening torque range is 0.8N•m to 1.0N•m.
4. The pre-drive low voltage protection is the feature to protect a device when the pre-driver supply voltage declines with the operating malfunction. As for the pre-driver supply voltage decline in case of operation beginning, and so on, we request confirmation in the set.

Package Dimensions

unit:mm (typ)

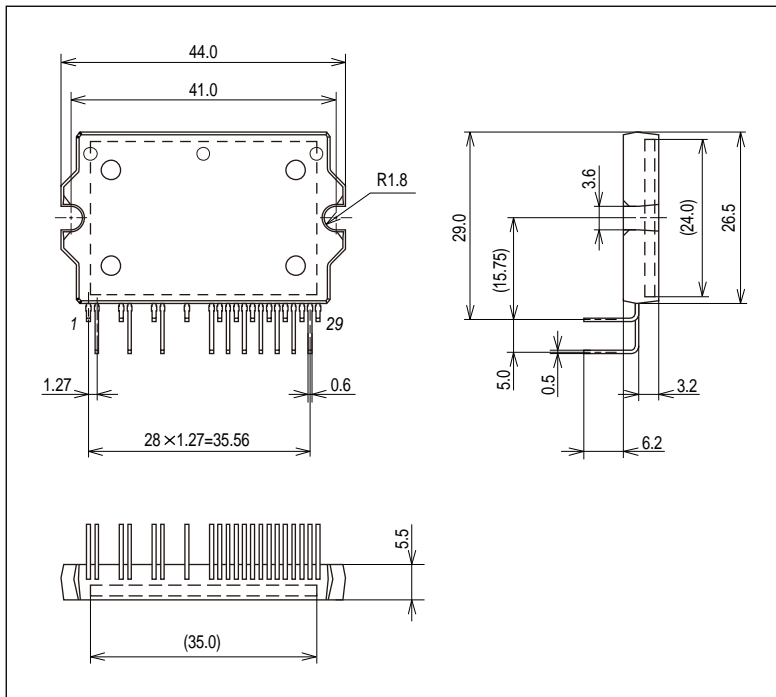

Internal equivalent circuit diagram

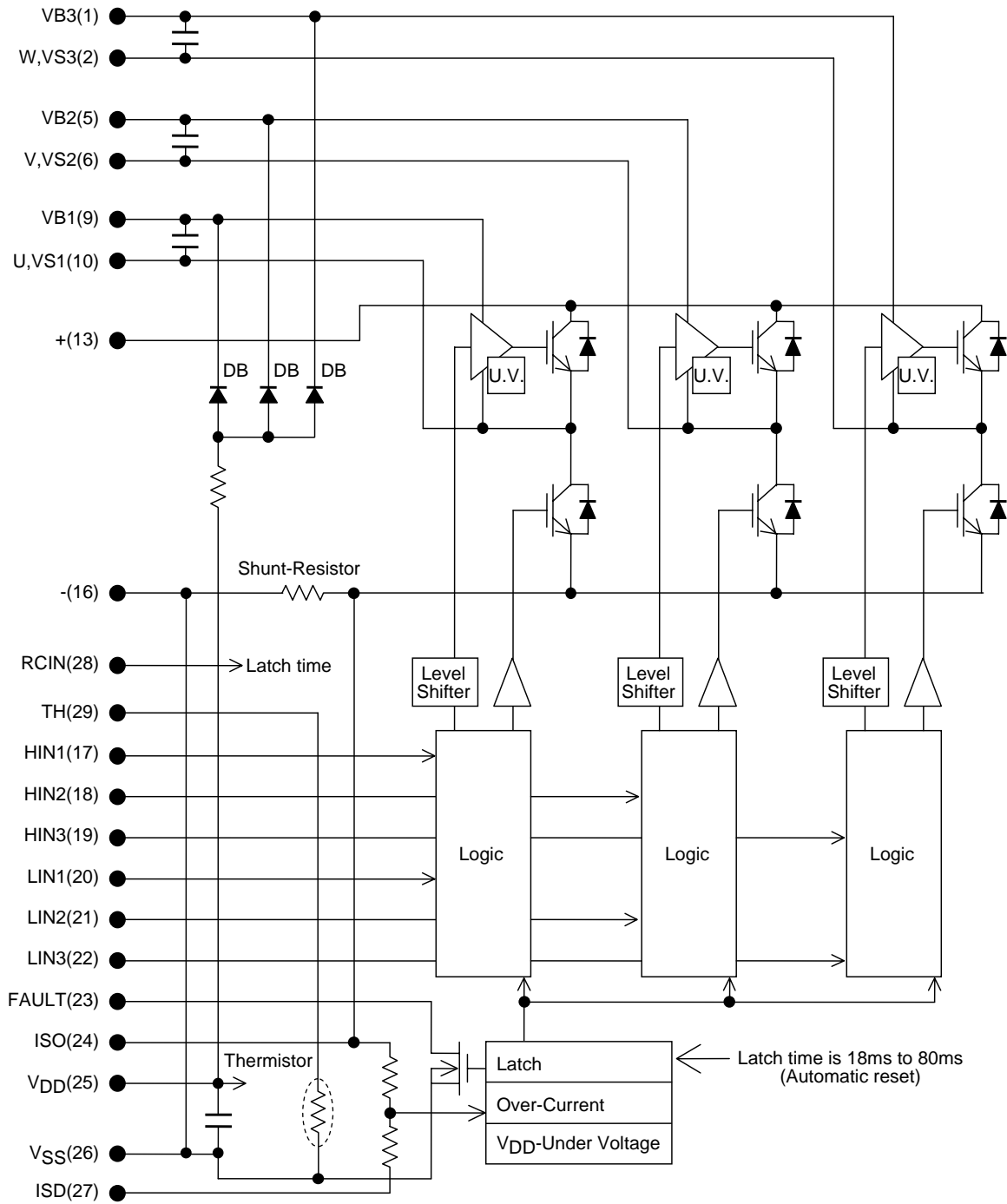

STK621-728-E

Example of the application circuit

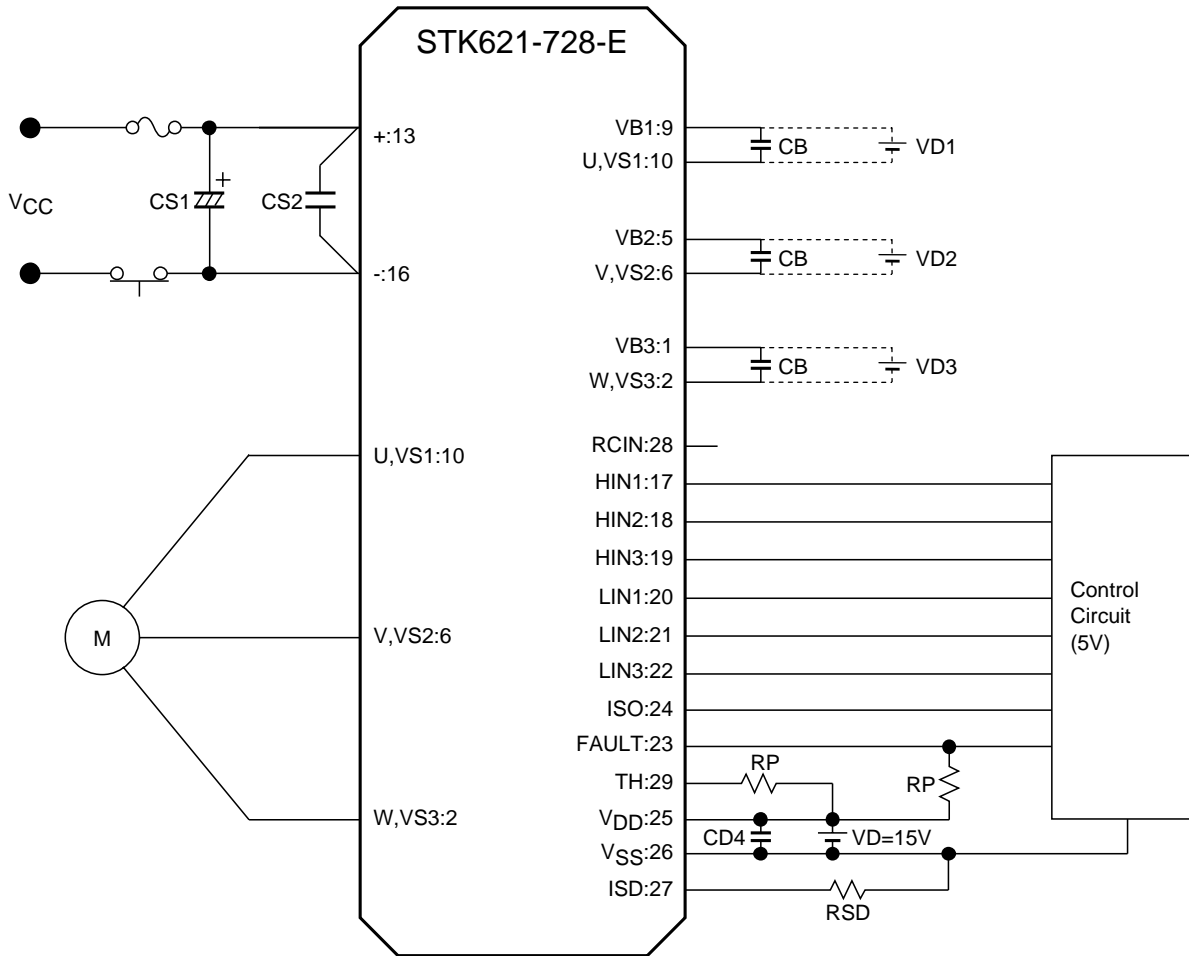

Recommendation Operating Conditions

Parameter	Symbol	Conditions	min	typ	max	unit
Supply voltage	V_{CC}	+ - - terminal	0	280	400	V
Pre-driver supply voltage	VD1, 2, 3	VB1 - U, VB2 - V, VB3 - W, terminal	12.5	15	17.5	V
	VD4	$V_{DD} - V_{SS}$ terminal *1	13.5	15	16.5	
ON state input voltage	$V_{IN} (ON)$	HIN1, HIN2, HIN3,	3.0		5.0	V
OFF state input voltage	$V_{IN} (OFF)$	LIN1, LIN2, LIN3 Terminal				
PWM frequency	fPWM		1		20	kHz
Dead-time	DT	Upper/lower input signal downtime	2			μs
Allowable input pulse width	PWIN	ON and OFF	1			μs
Tightening torque	MT	'M3' type screw	0.8		1.0	N·m

*1 Pre-driver power supply (VD4 = 15±1.5V) must have the capacity of $I_O = 20mA$ (DC), 0.5A (Peak).

Precautions

1. A control power supply can be driven with one power supply by attaching the capacitor CB (1 to 47 μ F) for a bootstrap. In this case, a bottom element is made to charge.
(When not using bootstrap circuit, each upper side pre-drive power supply needs an independent power supply. Externally set.)
In addition, please carry out capacity of the capacitor for a bootstrap (external) to 47 μ F (\pm 20%). When 47 μ F (\pm 20%) or more are connected, Please connect resistance (about 20 Ω) also with 3-phase at series between each top power supply terminal (VB1, 2, and 3) and the capacitor for a bootstrap. Moreover, since top power supply voltage may be insufficient depending on the control method, Please carry out a check with the system.
2. Because the jump voltage which is accompanied by the vibration in case of switching operation occurs by the influence of the floating inductance of the wiring of the outer power supply which is connected with of the + terminal and the – terminal, restrains and spares serge voltage being as the connection of the snubber circuit (Capacitor / CS / about 0.1 to 10 μ F) for the voltage absorption with the neighborhood as possible between + and the - terminal, and so on, with making a wiring length (among the terminals each from CI) short and making a wiring inductance small.
3. Output form of the FAULT terminal is open DRAIN (it is operating as FAULT when becoming low).
When pulling up the pin with a resistor, connect the resistor with a resistance of 5.6k Ω or more.
4. A thermistor is connected between the TH terminal (pin 29) and V_{SS} terminal (pin 26) inside the IC. The substrate temperature can be monitored by connecting an external pull-up resistor (RP). Connect the resistor with a resistance of 10k Ω or more when the pull-up voltage (VP) is 5V and 39k Ω or more when the VP is 15V.
5. ISO terminal (24 pin) is for the electric current monitor. Connect an external impedance with 5.6k Ω or more to this pin. In addition, Not short-circuit this pin to the V_{SS} pin, that leads to large current drain and is dangerous.
6. The pull-down resistor (: 33k Ω (typ)) is connected with the inside of the signal input terminal, but please connect the pull-down resistor (about 2.2 to 3.3k Ω) outside to decrease the influence of the noise by wiring etc.
7. The over-current protection feature operates only when it is possible to do a circuit control normally. For the safety, put a fuse, and so on in the V_{CC} line.
8. Because the IC sometimes destroys and bursts when motor connection terminal (2pin, 6pin, 10pin) becomes open while the motor turns, especially, be careful of the connection (the soldering condition) of this terminal.
9. Since the overcurrent protection function operates normally when an external resistor RSD is placed between the ISD and V_{SS} terminals, it must always be connected between the terminals (or the terminals must be short-circuited). The current level for overcurrent protection can be lowered by using the external resistor RSD of an appropriate value.
10. When input pulse width is less than 1 μ s, an output may not react to the pulse.
(Both ON signal and OFF signal)

* This data shows the example of the application circuit, does not guarantee a design as the mass production set.

- SANYO Semiconductor Co.,Ltd. assumes no responsibility for equipment failures that result from using products at values that exceed, even momentarily, rated values (such as maximum ratings, operating condition ranges, or other parameters) listed in products specifications of any and all SANYO Semiconductor Co.,Ltd. products described or contained herein.
- SANYO Semiconductor Co.,Ltd. strives to supply high-quality high-reliability products, however, any and all semiconductor products fail or malfunction with some probability. It is possible that these probabilistic failures or malfunction could give rise to accidents or events that could endanger human lives, trouble that could give rise to smoke or fire, or accidents that could cause damage to other property. When designing equipment, adopt safety measures so that these kinds of accidents or events cannot occur. Such measures include but are not limited to protective circuits and error prevention circuits for safe design, redundant design, and structural design.
- In the event that any or all SANYO Semiconductor Co.,Ltd. products described or contained herein are controlled under any of applicable local export control laws and regulations, such products may require the export license from the authorities concerned in accordance with the above law.
- No part of this publication may be reproduced or transmitted in any form or by any means, electronic or mechanical, including photocopying and recording, or any information storage or retrieval system, or otherwise, without the prior written consent of SANYO Semiconductor Co.,Ltd.
- Any and all information described or contained herein are subject to change without notice due to product/technology improvement, etc. When designing equipment, refer to the "Delivery Specification" for the SANYO Semiconductor Co.,Ltd. product that you intend to use.
- Information (including circuit diagrams and circuit parameters) herein is for example only; it is not guaranteed for volume production.
- Upon using the technical information or products described herein, neither warranty nor license shall be granted with regard to intellectual property rights or any other rights of SANYO Semiconductor Co.,Ltd. or any third party. SANYO Semiconductor Co.,Ltd. shall not be liable for any claim or suits with regard to a third party's intellectual property rights which has resulted from the use of the technical information and products mentioned above.

This catalog provides information as of October, 2010. Specifications and information herein are subject to change without notice.