

## High speed Driver with bootstrapping for dual Power MOSFETs

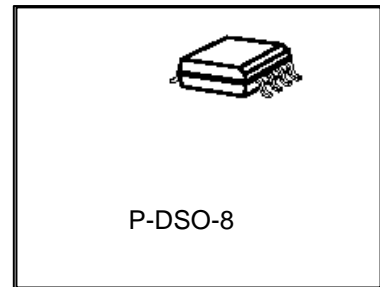

### Features

- Fast rise and fall times for frequencies up to 2 MHz
- Capable of sinking and sourcing of more than 4 A peak current for lowest switching losses
- Charges High Side (internally clamped to 10 V) and Low Side MOSFET's gates up to 12 V for lowest on-losses
- Adjustable High Side MOSFET gate drive voltage via high impedance PVCC pin for optimizing ON losses, gate drive losses, and switching losses
- Integrates the bootstrap diode for reducing the part count
- Prevents from cross-conducting by adaptive gate drive control
- Protects the driver against over-temperature
- Supports shut-down mode for very low quiescent current through three-state input
- Compatible to standard PWM controller ICs
- Floating High Side MOSFET drive up to 30 V
- Operates with  $V_{PVCC} = 5 \text{ to } 12 \text{ V} \pm 10\%$  → requires no separate supply voltage
- 1:1 compatible to HIP6601A and HIP6601B
- Ideal for multi-phase Desktop CPU supplies on motherboards and VRM's and Notebook CPU supplies

Type	Package	Marking	Ordering Code
TDA21101	P-DSO-8	21101G	Q67042-S4170-A101

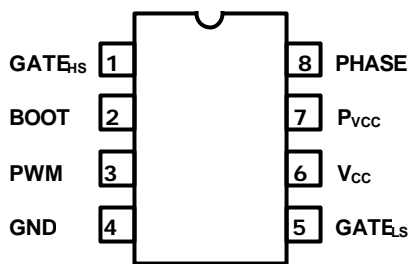
Pinout		Number	Name	Description
Top View		1	GATE <sub>HS</sub>	Gate drive output for the N-Channel High side MOSFET
		2	BOOT	Floating bootstrap pin. To be connected to the external bootstrap capacitor to generate the gate drive voltage for the high side N-Channel MOSFET
		3	PWM	Input for the PWM controller signal
		4	GND	Ground
		5	GATE <sub>LS</sub>	Gate drive output for the N-Channel Low Side MOSFET
		6	VCC	Supply voltage
		7	PVCC	High impedance input to adjust the High Side gate drive
		8	PHASE	This pin connects to the junction of the High Side and the Low Side MOSFET

## General Description

The dual high speed driver is designed to drive a wide range of N-Channel low side and N-Channel high side MOSFETs with varying gate charges. It has a small propagation delay from input to output, short rise and fall times and the same pin configuration to be compatible to HIP6601. In addition it provides several protection features as well as a shut down mode for efficiency reasons. The high breakdown voltage makes it suitable for mobile applications.

## Target application

The dual high speed driver is designed to work well in half-bridge type circuits where dual N-Channel MOSFETs are utilized. A circuit designer can fully take advantage of the driver's capabilities in high-efficiency, high-density synchronous DC/DC converters that operate at high switching frequencies, e.g. in multi-phase converters for CPU supplies on motherboards and VRM's but also in motor drive and class-D amplifier type applications.

## Absolute Maximum Ratings

At  $T_j = 25\text{ }^\circ\text{C}$ , unless otherwise specified

Parameter	Symbol	Value		Unit
		Min.	Max.	
Voltage supplied to 'VCC' pin	$V_{VCC}$	-0.3	20	V
Voltage supplied to 'PVCC' pin	$V_{PVCC}$	-0.3	20	
Voltage supplied to 'PWM' pin	$V_{PWM}$	-0.3	6.5	
Voltage supplied to 'BOOT' pin referenced to 'PHASE' (clamped by the TDA21101 to 10 V when PVCC > 10 V)	$V_{BOOT} - V_{PHASE}$	-0.3	10	
Voltage rating at 'PHASE' pin, DC	$V_{PHASE}$	-15	30	
Junction temperature	$T_J$		150	$^\circ\text{C}$
Storage temperature	$T_S$	-55	150	
ESD Rating; Human Body Model			4	kV
IEC climatic category; DIN EN 60068-1			55/150/56	-

## Thermal Characteristic

Parameter	Symbol	Values			Unit
		Min.	Typ.	Max.	
Thermal resistance, junction-soldering point			90		K/W
Thermal resistance, junction-ambient			125		

**Electrical Characteristic**

At Tj = 25 °C, unless otherwise specified

Parameter	Symbol	Conditions	Values			Unit
			Min.	Typ.	Max.	
<b>Supply Characteristic</b>						
Bias supply current	I <sub>VCC</sub>	f = 250 kHz, V <sub>PVCC</sub> = V <sub>VCC</sub> = 12 V		9.0	12	mA
Quiescent current	I <sub>VCCQ</sub>	1.8 V ≤ V <sub>PWM</sub> ≤ 3.0 V		4.5		mA
Power supply current	I <sub>PVCC</sub>	0.1 ≤ f ≤ 2 MHz, 5 V ≤ V <sub>PVCC</sub> ≤ 12 V	-500		500	nA
Under-voltage lockout		V <sub>VCC</sub> rising threshold	9.0	9.5	10	V
Under-voltage lockout		V <sub>VCC</sub> falling threshold	8.15	8.8	9.15	V
<b>Input Characteristic</b>						
Current in 'PWM' pin	I <sub>PWM_L</sub>	V <sub>PWM</sub> = 0.4 V		-120		μA
Current in 'PWM' pin	I <sub>PWM_H</sub>	V <sub>PWM</sub> = 4.5 V		180		
Shut down window	V <sub>IN_SHUT</sub>	t <sub>SHUT</sub> > 600 ns	1.8		3.0	V
Shut down hold-off time	t <sub>SHUT</sub>	1.8 V ≤ V <sub>PWM</sub> ≤ 3.0 V	320	450	600	ns
PWM pin open *	V <sub>PWM_O</sub>		1.8	2.0	2.2	V
PWM Low level threshold	V <sub>PWM_L</sub>		1.2	2.5		
PWM High level threshold	V <sub>PWM_H</sub>			2.5	3.9	

\* The driver IC will shut down and the High side MOSFET and the Low side MOSFET will be turned-off when the PWM input is open (e.g. PWM input disconnected or the PWM IC in a high-Z state)

At Tj = 25 °C, unless otherwise specified

<b>Dynamic Characteristic</b>						
Turn-on propagation Delay High Side	t <sub>d(ON)_HS</sub>	P <sub>PVCC</sub> = V <sub>VCC</sub> = 12 V C <sub>ISS</sub> = 3000 pF		58	70	ns
Turn-off propagation delay High Side	t <sub>d(OFF)_HS</sub>			40	50	
Rise time High Side	t <sub>r_HS</sub>			18	34	
Fall time High Side	t <sub>f_HS</sub>			18	30	
Turn-on propagation Delay Low Side	t <sub>d(ON)_LS</sub>			40	60	
Turn-off propagation delay Low Side	t <sub>d(OFF)_LS</sub>			30	40	
Rise time Low Side	t <sub>r_LS</sub>			19	32	
Fall time Low Side	t <sub>f_LS</sub>			17	25	
Turn-on propagation Delay High Side	t <sub>d(ON)_HS</sub>	P <sub>PVCC</sub> = V <sub>VCC</sub> = 12 V C <sub>ISS</sub> = 3000 pF T <sub>J</sub> = 125 °C		80		ns
Turn-off propagation delay High Side	t <sub>d(OFF)_HS</sub>			60		
Rise time High Side	t <sub>r_HS</sub>			18		
Fall time High Side	t <sub>f_HS</sub>			21		
Turn-on propagation Delay Low Side	t <sub>d(ON)_LS</sub>			50		

Turn-off propagation delay Low Side	$t_{d(OFF\_LS)}$		43		
Rise time Low Side	$t_{r\_LS}$		21		
Fall time Low Side	$t_{f\_LS}$		20		

**Operating Conditions**

At  $T_j = 25\text{ °C}$ , unless otherwise specified

Parameter	Symbol	Conditions	Values			Unit
			Min.	Typ.	Max.	
Voltage supplied to 'VCC' pins	$V_{VCC}$		10.8		13.2	V
Voltage supplied to 'PVCC' pins	$V_{PVCC}$		5		13.2	V
Input signal transition frequency	f		0.1		2	MHz
Power dissipation	$P_{TOT}$	$T_A = 25\text{ °C}, T_J = 125\text{ °C}$		0.8		W
Thermal shut down	$T_{OT}$	(Hysteresis = 50 °C)	135	150°	165	°C
Junction temperature	$T_J$		-25		125	°C

At  $T_j = 25\text{ °C}$ , unless otherwise specified

Parameter	Conditions	Values			Unit	
		Min.	Typ.	Max.		
<b>Output Characteristic High Side (HS) and Low Side (LS), ensured by design</b>						
Output Resistance and Voltage drop resp.	HS; Source *	$P_{PVCC} = V_{VCC} = 12\text{ V}$ $I_{HS\_SRC} = 2\text{ A}$		2.15		V
	HS; Sink	$V_{VCC} = 12\text{ V}, P_{PVCC} = 5\text{ V}$		1.2	1.9	Ω
	HS; Sink	$P_{PVCC} = V_{VCC} = 12\text{ V}$		0.95	1.5	
	LS; Source *	$P_{PVCC} = V_{VCC} = 12\text{ V}$ $I_{HS\_SRC} = 2\text{ A}$		2.15		V
	LS; Sink	$P_{PVCC} = V_{VCC} = 12\text{ V}$		0.7	1.0	Ω
Output Resistance and Voltage drop resp. (@ 125 °C)	HS; Source *	$P_{PVCC} = V_{VCC} = 12\text{ V}$ $I_{HS\_SRC} = 2\text{ A}, T_J = 125\text{ °C}$		1.65		V
	HS; Sink	$V_{VCC} = 12\text{ V}, P_{PVCC} = 5\text{ V}$ $T_J = 125\text{ °C}$		1.9		Ω
	HS; Sink	$P_{PVCC} = V_{VCC} = 12\text{ V}$ $T_J = 125\text{ °C}$		1.5		
	LS; Source *	$P_{PVCC} = V_{VCC} = 12\text{ V}$ $I_{HS\_SRC} = 2\text{ A}, T_J = 125\text{ °C}$		1.65		V
	LS; Sink	$P_{PVCC} = V_{VCC} = 12\text{ V}$ $T_J = 125\text{ °C}$		1.1		Ω
Peak output-current	HS; Source *	$P_{PVCC} = V_{VCC} = 12\text{ V}$ $D < 3\%$ $t_{P} / \text{Pulse} < 30\text{ ns}$	4			A
	HS; Sink		4			
	LS; Source *		4			
	LS; Sink		4			

\* The sourcing outputs of the LS and the HS terminals are bipolar and MOS transistors in parallel. The voltage drop is the voltage drop across the bipolar and MOS transistor combination; the peak output current is the combined output current the driver can deliver.

Published by  
**Infineon Technologies AG,**  
**Bereichs Kommunikation**  
**St.-Martin-Strasse 53,**  
**D-81541 München**  
© Infineon Technologies AG 1999  
**All Rights Reserved.**

**Attention please!**

The information herein is given to describe certain components and shall not be considered as warranted characteristics.

Terms of delivery and rights to technical change reserved.

We hereby disclaim any and all warranties, including but not limited to warranties of non-infringement, regarding circuits, descriptions and charts stated herein.

Infineon Technologies is an approved CECC manufacturer.

**Information**

For further information on technology, delivery terms and conditions and prices please contact your nearest Infineon Technologies Office in Germany or our Infineon Technologies Representatives worldwide (see address list).

**Warnings**

Due to technical requirements components may contain dangerous substances.  
For information on the types in question please contact your nearest Infineon Technologies Office.

Infineon Technologies Components may only be used in life-support devices or systems with the express written approval of Infineon Technologies, if a failure of such components can reasonably be expected to cause the failure of that life-support device or system, or to affect the safety or effectiveness of that device or system Life support devices or systems are intended to be implanted in the human body, or to support and/or maintain and sustain and/or protect human life. If they fail, it is reasonable to assume that the health of the user or other persons may be endangered.