

8-Bit Registers with Master Reset or Clock Enable

SN54/74LS273 SN54/74LS377

SN54/74S273 SN54/74S377

Features/Benefits

- 20-Pin SKINNYDIP® saves space
- 8-bit data path matches byte boundaries
- Ideal for microprogram instruction registers
- Ideal for microprogram interface
- Suitable for pipeline data registers
- Useful in timing, sequencing, and control circuits
- Three '273s may replace four '174s
- Three '377s may replace four '378s/Am25S07s

Description

These 8-bit registers contain eight D-type flip-flops, they feature very low I_{CC} (17 mA typical) on the low-power Schottky devices and very-high-speed operation on the Schottky devices. The '273 register is loaded on the rising edge of the clock (CK) and asyn-

Function Table '273

INPUTS		OUTPUT	
MR	CLOCK	DATA	Q
L	X	X	L
H	↑	H	H
H	↑	L	L
H	L or H or ↓	X	Q_0

Logic Symbols

8-Bit Register with Master Reset '273

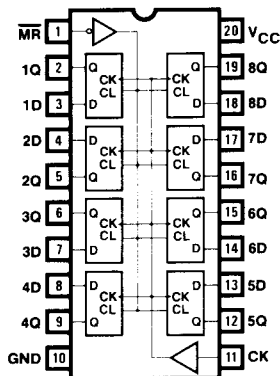

Ordering Information

PART NUMBER	PKG	TEMP	POLA-RITY	CONTROL OPTION	POWER
SN54LS273 SN74LS273	J,F,L,W N,J,L	Mil Com	Non-invert	Master Reset	LS
SN54LS377 SN74LS377	J,F,L,W N,J,L	Mil Com		Clock Enable	
SN54S273 SN74S273	J,F,L,W N,J,L	Mil Com	Non-invert	Master Reset	S
SN54S377 SN74S377	J,F,L,W N,J,L	Mil Com		Clock Enable	

chronously cleared whenever the master reset line, \overline{MR} , is low. The '377 register is loaded on the rising edge of the clock provided that the clock enable line, CK EN, is low.

All of the 8-bit devices are packaged in the popular 20-pin SKINNYDIP.

Function Table '377

INPUTS		OUTPUT	
CK EN	CLOCK	DATA	Q
H	X	X	Q_0
L	↑	H	H
L	↑	L	L
X	L or H or ↓	X	Q_0

8-Bit Register with Clock Enable '377

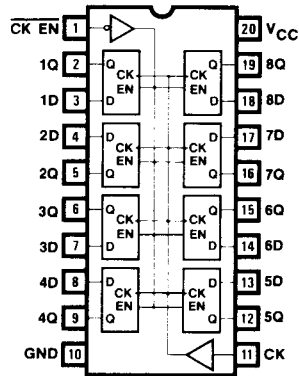

Absolute Maximum Ratings

Supply voltage V_{CC}	7 V
Input voltage	5.5 V
Off-state output voltage	5.5 V
Storage temperature range	-65° C to + 150° C

IEEE Symbols

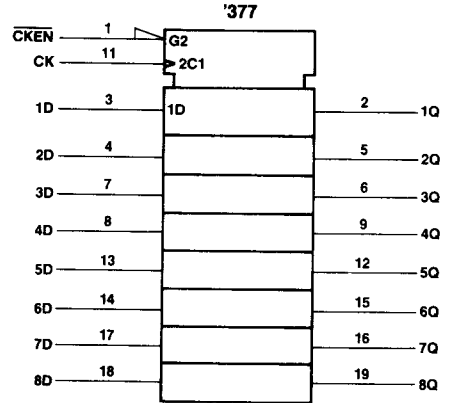
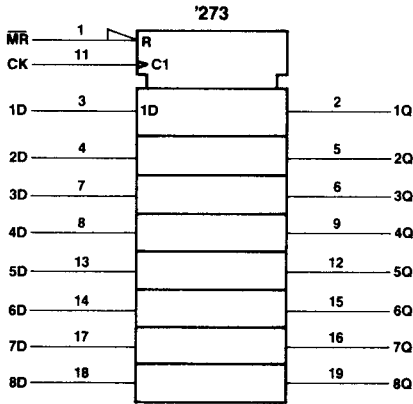

Operating Conditions

SYMBOL	PARAMETER	TEST CONDITIONS (See Interface, Test Load/Waveforms)	FIGURE	MILITARY			COMMERCIAL			UNIT	
				MIN	TYP	MAX	MIN	TYP	MAX		
V_{CC}	Supply voltage			4.5	5	5.5	4.75	5	5.25	V	
T_A	Operating free-air temperature			-55		125	0		75	°C	
t_W	Width of clock	High- t_{WH}	1	20			20			ns	
		Low- t_{WL}									
t_{WMR}	Width of Master Reset (LS273 only)	Low- t_{WMRL}	2	20			20			ns	
t_{rec}		\overline{MR} to CK (S273 only)	2	25 †			25 †			ns	
t_{su}	Setup time	Data input to CK	3	20 †			20 †			ns	
		Low $\overline{CK EN}$ to CK (LS377 only)		4	25 †			25 †			
		High $\overline{CK EN}$ to CK (LS377 only)			10 †			10 †			
t_h	Hold time	Data input	3	5 †			5 †			ns	
		Low $\overline{CK EN}$ to CK (LS377 only)		4	5 †			5 †			
		High $\overline{CK EN}$ to CK (LS377 only)			5 †			5 †			

† The arrow indicates the transition of the clock/enable input used for reference. † for the low-to-high transition. ‡ for the high-to-low transition.

Electrical Characteristics Over Operating Conditions

SYMBOL	PARAMETER	TEST CONDITIONS		MILITARY		COMMERCIAL		UNIT
				MIN	TYP	MAX	MIN	
V _{IL}	Low-level input voltage				0.7		0.8	V
V _{IH}	High-level input voltage			2		2		V
V _{IC}	Input clamp voltage	V _{CC} = MIN	I _I = -18 mA		-1.5		-1.5	V
I _{IL}	Low-level input current	V _{CC} = MAX	V _I = 0.4 V		-0.4		-0.4	mA
I _{IH}	High-level input current	V _{CC} = MAX	V _I = 2.7 V		20		20	μA
I _I	Maximum input current	V _{CC} = MAX	V _I = 7 V		0.1		0.1	mA
V _{OL}	Low-level output voltage	V _{CC} = MIN V _{IL} = MAX V _{IH} = 2 V	I _{OL} = 4 mA	0.25	0.4	0.25	0.4	V
			I _{OL} = 8 mA			0.35	0.5	
V _{OH}	High-level output voltage	V _{CC} = MIN V _{IL} = MAX V _{IH} = 2 V	I _{OH} = -400 μA	2.5	3.4	2.7	3.4	V
I _{OS}	Output short-circuit current*	V _{CC} = MAX		-20	-100	-20	-100	mA
I _{CC}	Supply current †	V _{CC} = MAX Outputs open	LS273	17	27	17	27	mA
			LS377	17	28	17	28	

* Note more than one output should be shorted at a time and duration of the short-circuit should not exceed one second

† I_{CC} is measured after first a momentary ground, and then 4.5 V is applied to clock, while the following other input conditions are held:

- (a) for the 'LS273 — 4.5 V on all data and master-reset inputs.
- (b) for the 'LS377 — ground on all data and clock-enable inputs.

Switching Characteristics V_{CC} = 5V, T_A = 25°C

SYMBOL	PARAMETER	TEST CONDITIONS (See Test Load/Waveforms)	LS273			LS377			UNIT
			MIN	TYP	MAX	MIN	TYP	MAX	
f _{MAX}	Maximum Clock frequency	C _L = 15 pF R _L = 2KΩ	30	40		35	40	MHz	
t _{PLH}	Clock to Output delay				27			27	ns
t _{PHL}					27			27	ns
t _{PHL}	Master Reset to output delay ('LS273 only)				27				ns

Absolute Maximum Ratings

Supply voltage V_{CC}	7 V
Input voltage	5.5 V
Off-state output voltage	5.5 V
Storage temperature range	-65° C to + 150° C

Operating Conditions

SYMBOL	PARAMETER	TEST CONDITIONS (See Interface, Test Load/Waveforms)	FIGURE	MILITARY			COMMERCIAL			UNIT
				MIN	TYP	MAX	MIN	TYP	MAX	
V_{CC}	Supply voltage			4.5	5	5.5	4.75	5	5.25	V
T_A	Operating free-air temperature			-55		125	0		75	°C
t_W	Width of clock	High- t_{WH}	1	7			7			ns
		Low- t_{WL}								
t_{WMR}	Width of Master Reset ('S273 only)	Low- t_{WMRL}	2	10			10			ns
t_{rec}		\overline{MR} to CK ('S273 only)	2	7 †			7 †			ns
t_{su}	Setup time	Data input to CK	3	5 †			5 †			ns
		Low $\overline{CK EN}$ to CK ('S377 only)	4	9 †			9 †			
		High $\overline{CK EN}$ to CK ('S377 only)	4	9 †			9 †			
t_h	Hold time	Data input	3	3 †			3 †			ns ns
		Low $\overline{CK EN}$ to CK ('S377 only)	4	3 †			3 †			
		High $\overline{CK EN}$ to CK ('S377 only)		0 †			0 †			

† The arrow indicates the transition of the clock/enable input used for reference. † for the low-to-high transition, ‡ for the high-to-low transition.

Electrical Characteristics Over Operating Conditions

SYMBOL	PARAMETER	TEST CONDITIONS		MILITARY			COMMERCIAL			UNIT
				MIN	TYP	MAX	MIN	TYP	MAX	
V_{IL}	Low-level input voltage					0.8			0.8	V
V_{IH}	High-level input voltage			2			2			V
V_{IC}	Input clamp voltage	$V_{CC} = \text{MIN}$	$I_I = -18 \text{ mA}$			-1.2			-1.2	V
I_{IL}	Low-level input current	$V_{CC} = \text{MAX}$	$V_I = 0.5 \text{ V}$			-250			-250	µA
I_{IH}	High-level input current	$V_{CC} = \text{MAX}$	$V_I = 2.7 \text{ V}$			50			50	µA
I_I	Maximum input current	$V_{CC} = \text{MAX}$	$V_I = 5.5 \text{ V}$			1			1	mA
V_{OL}	Low-level output voltage	$V_{CC} = \text{MIN}$ $V_{IL} = \text{MAX}$ $V_{IH} = 2 \text{ V}$	$I_{OL} = 20 \text{ mA}$			0.5			0.5	V
V_{OH}	High-level output voltage	$V_{CC} = \text{MIN}$ $V_{IL} = \text{MAX}$ $V_{IH} = 2 \text{ V}$	$I_{OH} = -1 \text{ mA}$	2.5	3.4		2.7	3.4		V
I_{OS}	Output short-circuit current*	$V_{CC} = \text{MAX}$		-40		-100	-40		-100	mA
I_{CC}	Supply current †	$V_{CC} = \text{MAX}$	'S273	150			150			mA
		Outputs open	'S377	160			160			

* Not more than one output should be shorted at a time and duration of the short-circuit should not exceed one second

Switching Characteristics $V_{CC} = 5V, T_A = 25^\circ C$

SYMBOL	PARAMETER	TEST CONDITIONS (See Test Load/Waveforms)	'S273			'S377			UNIT
			MIN	TYP	MAX	MIN	TYP	MAX	
f _{MAX}	Maximum Clock frequency	C _L = 15 pF R _L = 280Ω	75	110		75	110		MHz
t _{PLH}	Clock to Output delay			6	15		6	15	ns
t _{PHL}				9	15		9	15	ns
t _{PHL}	Master Reset to output delay (‘S273 only)			13	22				ns

CLOCK PULSE WIDTH AND CLOCK TO OUTPUT DELAYS

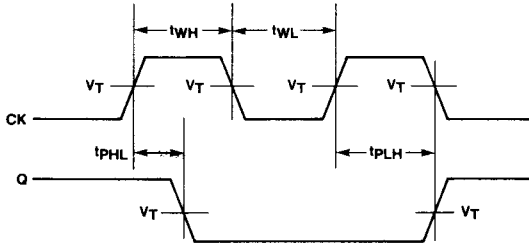

Figure 1

DATA SET-UP AND HOLD TIMES

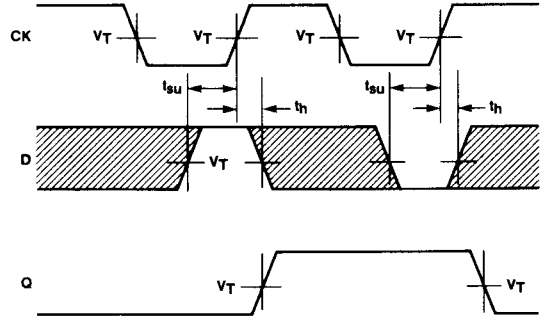

Figure 3

MASTER RESET PULSE WIDTH, MASTER RESET TO OUTPUT DELAY AND MASTER RESET TO CLOCK RECOVERY TIME FOR 'S273

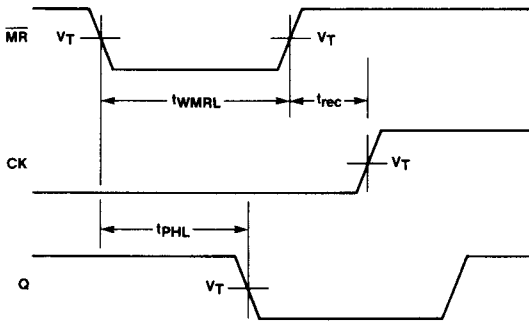

Figure 2

CLOCK ENABLE SETUP AND HOLD TIMES FOR 'S377

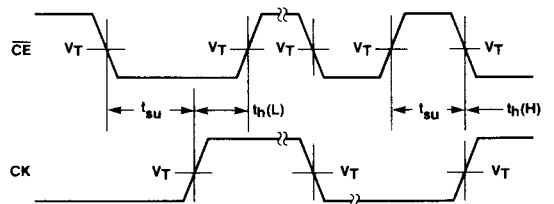
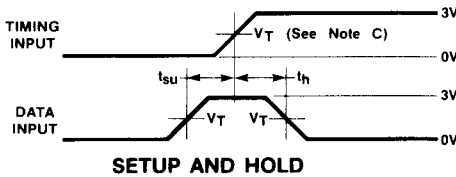
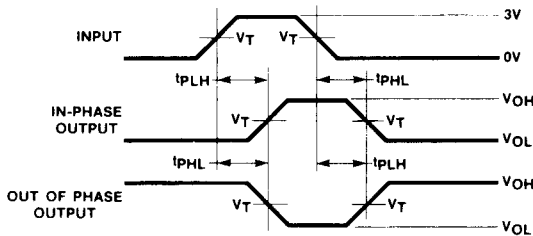

Figure 4

Test Waveforms



SETUP AND HOLD



PROPAGATION DELAY

Test Load

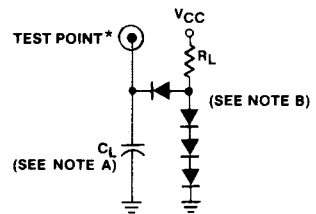

* The "TEST POINT" is driven by the output under test, and observed by instrumentation.

LOAD CIRCUIT FOR BI-STATE TOTEM-POLE OUTPUTS

- NOTES: A. C_L includes probe and jig capacitance.
- B. All diodes are 1N916 or 1N3064.
- C. For Series 54/74S, $V_T = 1.5$ V.
For Series 54/74LS, $V_T = 1.3$ V.
- D. In the examples above the phase relationships between inputs and outputs have been chosen arbitrarily.
- E. All input pulses are supplied by generators having the following characteristics: $PRR \leq 1$ MHz, $Z_{OUT} = 50\Omega$ and:
For Series 54/74S, $t_R \leq 2.5$ ns, $t_P \leq 2.5$ ns.

Die Configurations

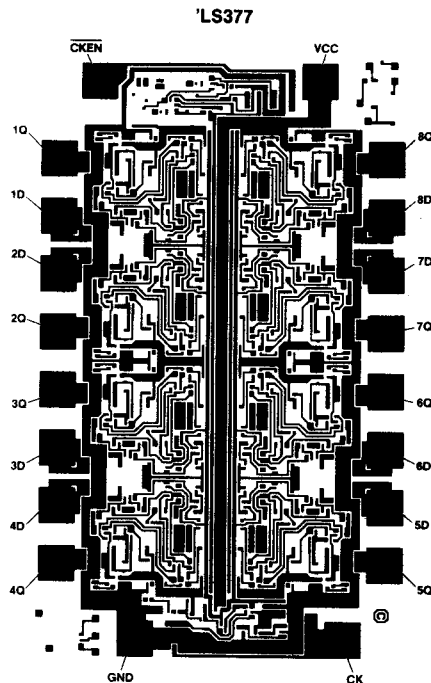
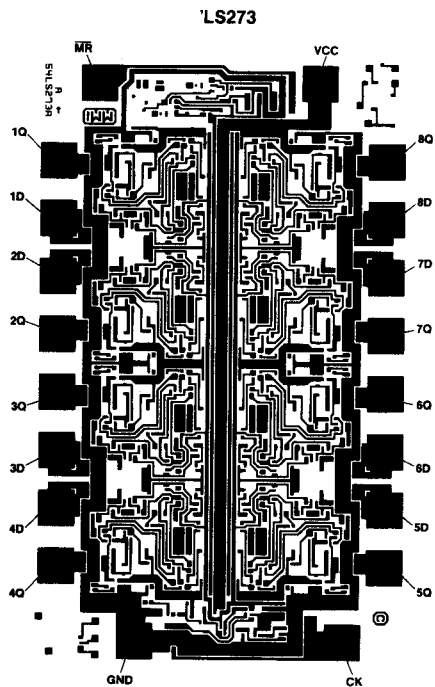

Die Size: 58x93 mil²

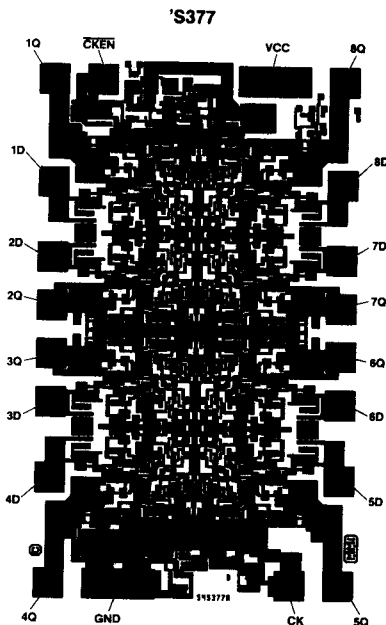
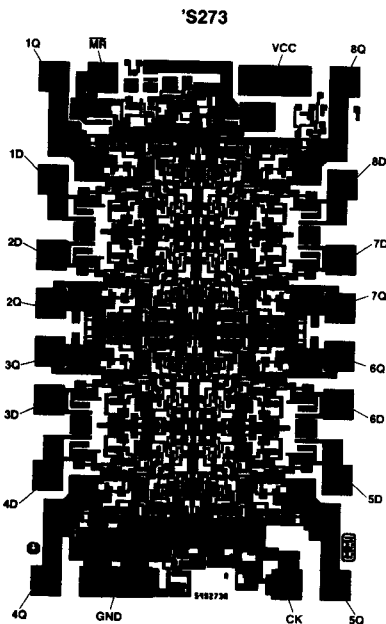

Die Size: 56x87 mil²