

# 74HC40105; 74HCT40105

## 4-bit x 16-word FIFO register

Rev. 4 — 29 January 2016

Product data sheet

## 1. General description

---

The 74HC40105; 74HCT40105 is a first-in/first-out (FIFO) "elastic" storage register that can store 16 4-bit words. It can handle input and output data at different shifting rates. This feature makes it particularly useful as a buffer between asynchronous systems. Each word position in the register is clocked by a control flip-flop, which stores a marker bit. A logic 1 signifies that the data at that position is filled and a logic 0 denotes a vacancy in that position. The control flip-flop detects the state of the preceding flip-flop and communicates its own status to the succeeding flip-flop. When a control flip-flop is in the logic 0 state and sees a logic 1 in the preceding flip-flop, it generates a clock pulse. The clock pulse transfers data from the preceding four data latches into its own four data latches and resets the preceding flip-flop to logic 0. The first and last control flip-flops have buffered outputs. All empty locations "bubble" automatically to the input end, and all valid data ripples through to the output end. As a result, the status of the first control flip-flop (data-in ready output - DIR) indicates if the FIFO is full. The status of the last flip-flop (data-out ready output - DOR) indicates whether the FIFO contains data. As the earliest data is removed from the bottom of the data stack (output end), all data entered later will automatically ripple toward the output. Inputs include clamp diodes that enable the use of current limiting resistors to interface inputs to voltages in excess of  $V_{CC}$ .

## 2. Features and benefits

---

- Independent asynchronous inputs and outputs
- Expandable in either direction
- Reset capability
- Status indicators on inputs and outputs
- 3-state outputs
- Input levels:
  - ◆ For 74HC40105: CMOS level
  - ◆ For 74HCT40105: TTL level
- 3-state outputs
- Complies with JEDEC standard JESD7A
- ESD protection:
  - ◆ HBM JESD22-A114F exceeds 2 000 V
  - ◆ MM JESD22-A115-A exceeds 200 V
- Multiple package options
- Specified from  $-40\text{ }^{\circ}\text{C}$  to  $+85\text{ }^{\circ}\text{C}$  and from  $-40\text{ }^{\circ}\text{C}$  to  $+125\text{ }^{\circ}\text{C}$

### 3. Ordering information

Table 1. Ordering information

Type number	Package			Version
	Temperature range	Name	Description	
74HC40105D	-40 °C to +125 °C	SO16	plastic small outline package; 16 leads; body width 3.9 mm	SOT109-1
74HCT40105D				
74HC40105DB	-40 °C to +125 °C	SSOP16	plastic shrink small outline package; 16 leads; body width 5.3 mm	SOT338-1
74HCT40105DB				
74HC40105PW	-40 °C to +125 °C	TSSOP16	plastic thin shrink small outline package; 16 leads; body width 4.4 mm	SOT403-1

### 4. Functional diagram

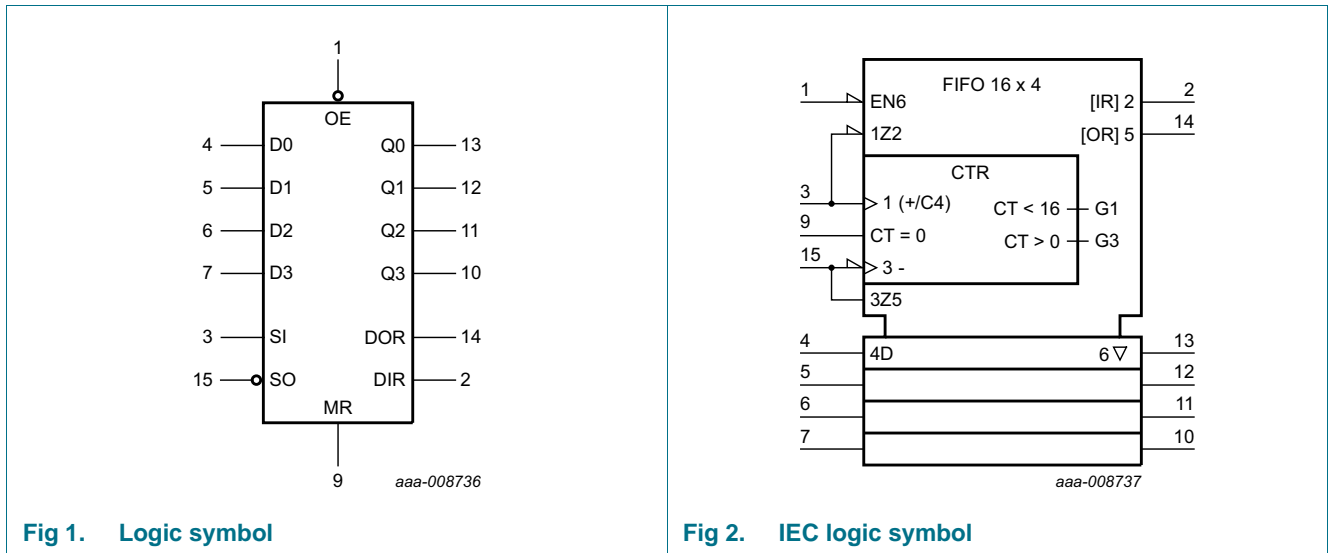

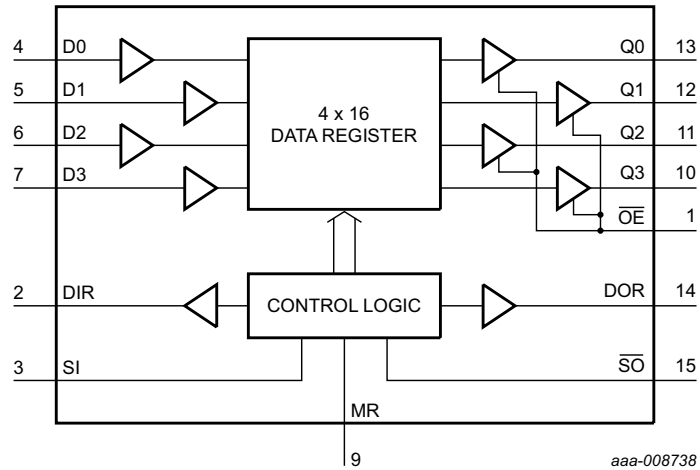

**Fig 3. Functional diagram**

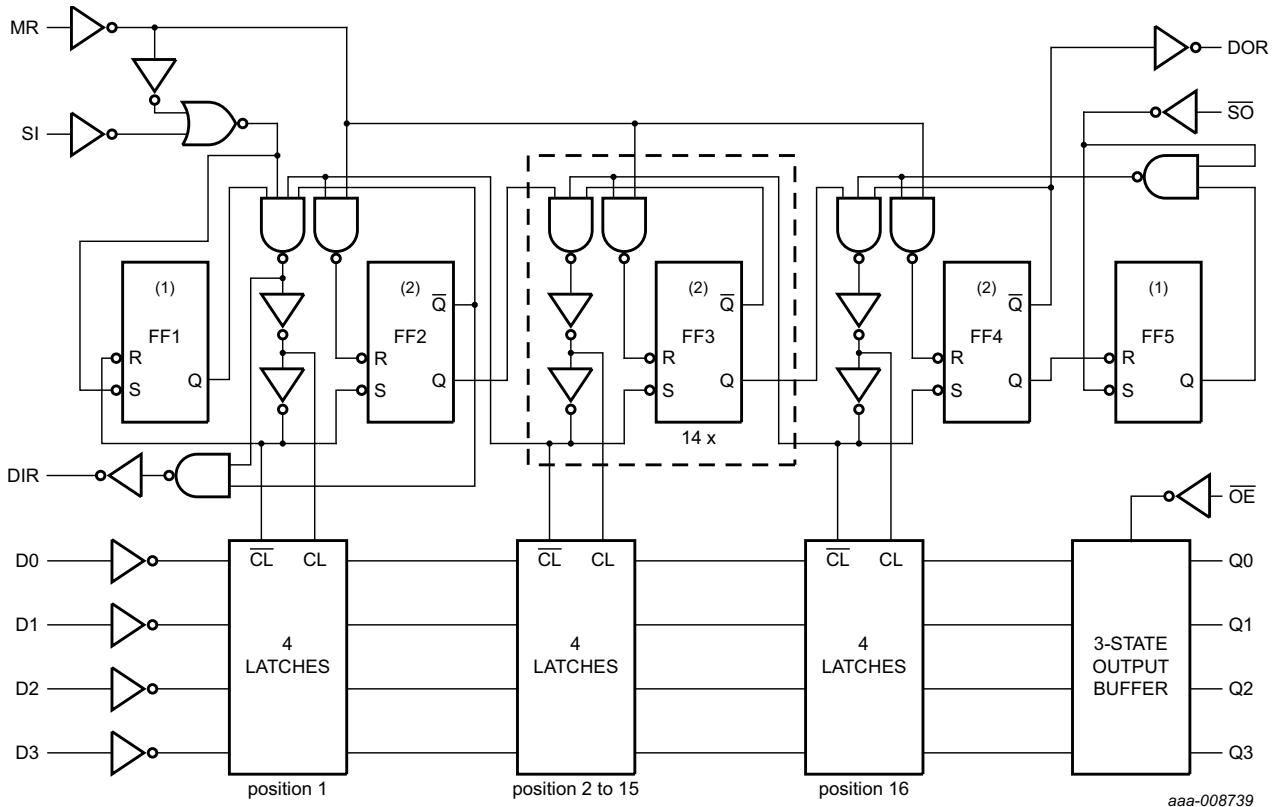

LOW on  $\bar{S}$  input of FF1 and FF5 sets Q output to HIGH independent of state on  $\bar{R}$  input.  
 LOW on  $\bar{R}$  input of FF2, FF3 and FF4 sets Q output to LOW independent of state on  $\bar{S}$  input.

**Fig 4. Logic diagram**

## 5. Pinning information

### 5.1 Pinning

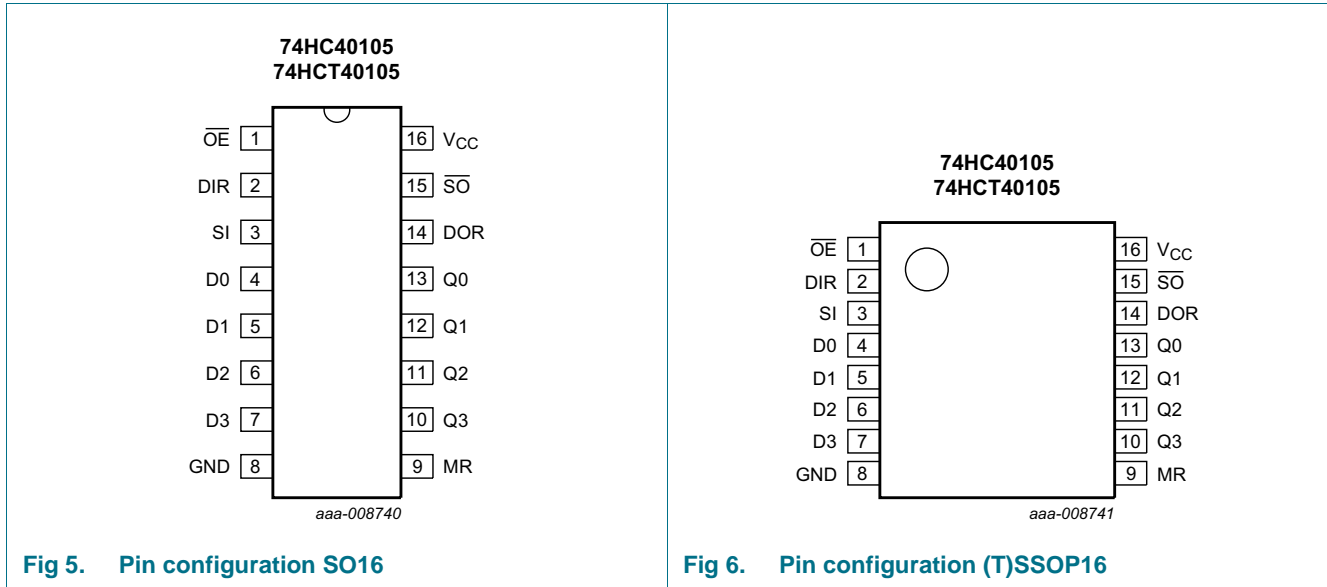

### 5.2 Pin description

**Table 2. Pin description**

Symbol	Pin	Description
$\overline{OE}$	1	output enable input (active LOW)
DIR	2	data-in-ready output
SI	3	shift-in input (LOW-to-HIGH, edge triggered)
D0 to D3	4, 5, 6, 7	parallel data input
GND	8	ground (0 V)
MR	9	asynchronous master-reset input (active HIGH)
Q0 to Q3	13, 12, 11, 10	data output
DOR	14	data-out-ready output
$\overline{SO}$	15	shift-out input (HIGH-to-LOW, edge triggered)
V <sub>CC</sub>	16	supply voltage

## 6. Functional description

### 6.1 Inputs and outputs

#### 6.1.1 Data inputs (D0 to D3)

As there is no weighting of the inputs, any input can be assigned as the MSB. The size of the FIFO memory can be reduced from the 4 x 16 configuration. For example, it can be reduced to 3 x 16, down to 1 x 16, by tying unused data input pins to  $V_{CC}$  or GND.

#### 6.1.2 Data outputs (Q0 to Q3)

As there is no weighting of the outputs, any output can be assigned as the MSB. The size of the FIFO memory can be reduced from the 4 x 16 configuration as described for data inputs. In a reduced format, the unused data outputs pins must be left open circuit.

#### 6.1.3 Master-reset (MR)

When MR is HIGH, the control functions within the FIFO are cleared, and data content is declared invalid. The data-in ready (DIR) flag is set HIGH and the data-out-ready (DOR)

flag is set LOW. The output stage remains in the state of the last word that was shifted out, or in the random state existing at power-up.

#### 6.1.4 Status flag outputs (DIR, DOR)

Two status flags, data-in-ready (DIR) and data-out-ready (DOR), indicate the status of the FIFO:

1. DIR = HIGH indicates that the input stage is empty and ready to accept valid data;
2. DIR = LOW indicates that the FIFO is full or that a previous shift-in operation is not complete (busy);
3. DOR = HIGH assures valid data is present at the outputs Q0 to Q3 (does not indicate that new data is awaiting transfer into the output stage);
4. DOR = LOW indicates that the output stage is busy or there is no valid data.

#### 6.1.5 Shift-in control (SI)

Data is loaded into the input stage on a LOW-to-HIGH transition of SI. It also triggers an automatic data transfer process (ripple through). If SI is held HIGH during reset, data is loaded at the falling edge of the MR signal.

#### 6.1.6 Shift-out control ( $\overline{SO}$ )

A HIGH-to-LOW transition of  $\overline{SO}$  causes the DOR flags to go LOW. A HIGH-to-LOW transition of  $\overline{SO}$  causes upstream data to move into the output stage, and empty locations to move towards the input stage (bubble-up).

#### 6.1.7 Output enable ( $\overline{OE}$ )

The outputs Q0 to Q3 are enabled when  $\overline{OE}$  = LOW. When  $\overline{OE}$  = HIGH the outputs are in the high impedance OFF-state.

## 6.2 Data input

Following power-up, the master-reset (MR) input is pulsed HIGH to clear the FIFO memory (see [Figure 7](#)). The data-in-ready flag (DIR = HIGH) indicates that the FIFO input stage is empty and ready to receive data. When DIR is valid (HIGH), data present at D0 to D3 can be shifted-in using the SI control input. With SI = HIGH, data is shifted into the input stage. DIR going LOW provides a busy indication. The data remains at the first location in the FIFO until DIR is set to HIGH and data moves through the FIFO to the output stage, or to the last empty location. If the FIFO is not full after the SI pulse, DIR again becomes valid (HIGH) to indicate that space is available in the FIFO. The DIR flag remains LOW if the FIFO is full (see [Figure 8](#)). To complete the shift-in process, the SI use must be made LOW. With the FIFO full, SI can be held HIGH until a shift-out ( $\overline{SO}$ ) pulse occurs. Then, following a shift-out of data, an empty location appears at the FIFO input and DIR goes HIGH to allow the next data to be shifted-in. This data remains at the first FIFO location until SI goes LOW (see [Figure 9](#)).

## 6.3 Data transfer

After data has been transferred from the input stage of the FIFO following SI = LOW, data moves through the FIFO asynchronously and is stacked at the output end of the register. Empty locations appear at the input end of the FIFO as data moves through the device.

## 6.4 Data output

The data-out-ready flag (DOR = HIGH) indicates that there is valid data at the output (Q0 to Q3). The initial master-reset at power-on (MR = HIGH) sets DOR to LOW (see [Figure 7](#)). After MR = LOW, data shifted into the FIFO moves through to the output stage causing DOR to go HIGH. As the DOR flag goes HIGH, data can be shifted-out using the  $\overline{SO}$  = HIGH, data in the output stage is shifted out. DOR going LOW provides a busy indication. When  $\overline{SO}$  is made LOW, data moves through the FIFO to fill the output stage and an empty location appears at the input stage. When the output stage is filled DOR goes HIGH, but if the last of the valid data has been shifted-out leaving the FIFO empty the DOR flag remains LOW (see [Figure 11](#)). With the FIFO empty, the last word that was shifted-out is latched at the output Q0 to Q3.

With the FIFO empty, the  $\overline{SO}$  input can be held HIGH until the SI control input is used. Following an SI pulse, data moves through the FIFO to the output stage, resulting in the DOR flag pulsing HIGH and a shift-out of data occurring. The  $\overline{SO}$  control must be made LOW before additional data can be shifted-out (see [Figure 14](#)).

## 6.5 High-speed burst mode

Assuming the shift-in/shift-out pulses are not applied until the respective status flags are valid, it follows that the status flags determine the shift-in/shift-out rates. However, without the status flags, a high-speed burst can be implemented. In this mode, pulse widths determine the burst-in/ burst-out rates of the shift-in/shift-out inputs. Burst rates of 35 MHz can be obtained. Shift pulses can be applied without regard to the status flags but shift-in pulses that would overflow the storage capacity of the FIFO are not allowed (see [Figure 12](#) and [Figure 13](#)).

## 6.6 Expanded format

With the addition of a logic gate, the FIFO is easily expanded to increase word length (see [Figure 19](#)). The basic operation and timing are identical to a single FIFO, except for an additional gate delay on the flag outputs. If during application, the following occurs:

- SI is held HIGH when the FIFO is empty, some additional logic is required to produce a composite DIR pulse (see [Figure 9](#) and [Figure 20](#)).

Due to the part-to-part spread of the ripple through time, the SI signals of FIFOA and FIFOB do not always coincide. As a result, the AND-gate does not produce a composite flag signal. The solution is given in [Figure 20](#). The “40105” is easily cascaded to increase the word capacity and no external components are needed. In the cascaded configuration, the FIFOs perform all necessary communications and timing. The minimum flag pulse widths and the flag delays determine the intercommunication speed. The data rate of cascaded devices is typically 25 MHz. Word-capacity can be expanded to and beyond 32-words x 4-bits (see [Figure 21](#)).

## 7. Limiting values

**Table 3. Limiting values**

In accordance with the Absolute Maximum Rating System (IEC 60134). Voltages are referenced to GND (ground = 0 V).

Symbol	Parameter	Conditions	Min	Max	Unit
$V_{CC}$	supply voltage		-0.5	+7	V
$I_{IK}$	input clamping current	$V_I < -0.5\text{ V}$ or $V_I > V_{CC} + 0.5\text{ V}$ <a href="#">[1]</a>	-	$\pm 20$	mA
$I_{OK}$	output clamping current	$V_O < -0.5\text{ V}$ or $V_O > V_{CC} + 0.5\text{ V}$ <a href="#">[1]</a>	-	$\pm 20$	mA
$I_O$	output current	$V_O = -0.5\text{ V}$ to $(V_{CC} + 0.5\text{ V})$	-	$\pm 25$	mA
$I_{CC}$	supply current		-	+50	mA
$I_{GND}$	ground current		-50	-	mA
$T_{stg}$	storage temperature		-65	+150	°C
$P_{tot}$	total power dissipation	SO16 package <a href="#">[2]</a>	-	500	mW
		(T)SSOP16 package <a href="#">[3]</a>	-	500	mW

[1] The input and output voltage ratings may be exceeded if the input and output current ratings are observed.

[2] For SO16 packages: above 70 °C the value of  $P_{tot}$  derates linearly with 8 mW/K.

[3] For SSOP16 and TSSOP16 packages: above 60 °C the value of  $P_{tot}$  derates linearly with 5.5 mW/K.

## 8. Recommended operating conditions

**Table 4. Recommended operating conditions**

Voltages are referenced to GND (ground = 0 V)

Symbol	Parameter	Conditions	74HC40105			74HCT40105			Unit
			Min	Typ	Max	Min	Typ	Max	
V <sub>CC</sub>	supply voltage		2.0	5.0	6.0	4.5	5.0	5.5	V
V <sub>I</sub>	input voltage		0	-	V <sub>CC</sub>	0	-	V <sub>CC</sub>	V
V <sub>O</sub>	output voltage		0	-	V <sub>CC</sub>	0	-	V <sub>CC</sub>	V
T <sub>amb</sub>	ambient temperature		-40	+25	+125	-40	+25	+125	°C
Δt/ΔV	input transition rise and fall rate	V <sub>CC</sub> = 2.0 V	-	-	625	-	-	-	ns/V
		V <sub>CC</sub> = 4.5 V	-	1.67	139	-	1.67	139	ns/V
		V <sub>CC</sub> = 6.0 V	-	-	83	-	-	-	ns/V

## 9. Static characteristics

**Table 5. Static characteristics**

At recommended operating conditions; voltages are referenced to GND (ground = 0 V).

Symbol	Parameter	Conditions	25 °C			-40 °C to +85 °C		-40 °C to +125 °C		Unit
			Min	Typ	Max	Min	Max	Min	Max	
<b>74HC40105</b>										
V <sub>IH</sub>	HIGH-level input voltage	V <sub>CC</sub> = 2.0 V	1.5	1.2	-	1.5	-	1.5	-	V
		V <sub>CC</sub> = 4.5 V	3.15	2.4	-	3.15	-	3.15	-	V
		V <sub>CC</sub> = 6.0 V	4.2	3.2	-	4.2	-	4.2	-	V
V <sub>IL</sub>	LOW-level input voltage	V <sub>CC</sub> = 2.0 V	-	0.8	0.5	-	0.5	-	0.5	V
		V <sub>CC</sub> = 4.5 V	-	2.1	1.35	-	1.35	-	1.35	V
		V <sub>CC</sub> = 6.0 V	-	2.8	1.8	-	1.8	-	1.8	V
V <sub>OH</sub>	HIGH-level output voltage	V <sub>I</sub> = V <sub>IH</sub> or V <sub>IL</sub>								
		I <sub>O</sub> = -20 μA; V <sub>CC</sub> = 2.0 V	1.9	2.0	-	1.9	-	1.9	-	V
		I <sub>O</sub> = -20 μA; V <sub>CC</sub> = 4.5 V	4.4	4.5	-	4.4	-	4.4	-	V
		I <sub>O</sub> = -20 μA; V <sub>CC</sub> = 6.0 V	5.9	6.0	-	5.9	-	5.9	-	V
		I <sub>O</sub> = -4 mA; V <sub>CC</sub> = 4.5 V	3.98	4.32	-	3.84	-	3.7	-	V
V <sub>OL</sub>	LOW-level output voltage	V <sub>I</sub> = V <sub>IH</sub> or V <sub>IL</sub>								
		I <sub>O</sub> = 20 μA; V <sub>CC</sub> = 2.0 V	-	0	0.1	-	0.1	-	0.1	V
		I <sub>O</sub> = 20 μA; V <sub>CC</sub> = 4.5 V	-	0	0.1	-	0.1	-	0.1	V
		I <sub>O</sub> = 20 μA; V <sub>CC</sub> = 6.0 V	-	0	0.1	-	0.1	-	0.1	V
		I <sub>O</sub> = 4 mA; V <sub>CC</sub> = 4.5 V	-	0.15	0.26	-	0.33	-	0.4	V
I <sub>OZ</sub>	OFF-state output current	I <sub>O</sub> = 5.2 mA; V <sub>CC</sub> = 6.0 V	-	0.15	0.26	-	0.33	-	0.4	V
			-	-	±0.5	-	±5.0	-	±10.0	μA
I <sub>I</sub>	input leakage current	V <sub>I</sub> = V <sub>CC</sub> or GND; V <sub>CC</sub> = 6.0 V	-	-	±0.1	-	±1.0	-	±1.0	μA
I <sub>OZ</sub>	OFF-state output current	V <sub>I</sub> = V <sub>IH</sub> or V <sub>IL</sub> ; V <sub>O</sub> = V <sub>CC</sub> or GND; V <sub>CC</sub> = 6.0 V	-	-	±0.5	-	±5.0	-	±10.0	μA



**Table 5. Static characteristics ...continued**

At recommended operating conditions; voltages are referenced to GND (ground = 0 V).

Symbol	Parameter	Conditions	25 °C			-40 °C to +85 °C		-40 °C to +125 °C		Unit
			Min	Typ	Max	Min	Max	Min	Max	
$I_{CC}$	supply current	$V_I = V_{CC}$ or GND; $I_O = 0$ A; $V_{CC} = 6.0$ V	-	-	8	-	80	-	160	$\mu$ A
$C_I$	input capacitance		-	3.5	-	-	-	-	-	pF
<b>74HCT40105</b>										
$V_{IH}$	HIGH-level input voltage	$V_{CC} = 4.5$ V to 5.5 V	2.0	1.6	-	2.0	-	2.0	-	V
$V_{IL}$	LOW-level input voltage	$V_{CC} = 4.5$ V to 5.5 V	-	1.2	0.8	-	0.8	-	0.8	V
$V_{OH}$	HIGH-level output voltage	$V_I = V_{IH}$ or $V_{IL}$ ; $V_{CC} = 4.5$ V								
		$I_O = -20$ $\mu$ A	4.4	4.5	-	4.4	-	4.4	-	V
		$I_O = -4$ mA	3.98	4.32	-	3.84	-	3.7	-	V
$V_{OL}$	LOW-level output voltage	$V_I = V_{IH}$ or $V_{IL}$ ; $V_{CC} = 4.5$ V								
		$I_O = 20$ $\mu$ A	-	0	0.1	-	0.1	-	0.1	V
		$I_O = 4$ mA	-	0.15	0.26	-	0.33	-	0.4	V
$I_I$	input leakage current	$V_I = V_{CC}$ or GND; $V_{CC} = 5.5$ V	-	-	$\pm 0.1$	-	$\pm 1.0$	-	$\pm 1.0$	$\mu$ A
$I_{OZ}$	OFF-state output current	$V_I = V_{IH}$ or $V_{IL}$ ; $V_O = V_{CC}$ or GND; $V_{CC} = 5.5$ V	-	-	$\pm 0.5$	-	$\pm 5.0$	-	$\pm 10$	$\mu$ A
$I_{CC}$	supply current	$V_I = V_{CC}$ or GND; $I_O = 0$ A; $V_{CC} = 5.5$ V	-	-	8	-	80	-	160	$\mu$ A
$\Delta I_{CC}$	additional supply current	$V_I = V_{CC} - 2.1$ V; other inputs at $V_{CC}$ or GND; $V_{CC} = 4.5$ V to 5.5 V; $I_O = 0$ A								
		per input pin; Dn inputs	-	30	108	-	135	-	147	$\mu$ A
		per input pin; $\overline{OE}$ input	-	75	270	-	338	-	368	$\mu$ A
		per input pin; SI input	-	40	144	-	180	-	196	$\mu$ A
		per input pin; MR input	-	150	540	-	675	-	735	$\mu$ A
		per input pin; $\overline{SO}$ input	-	40	144	-	180	-	196	$\mu$ A
$C_I$	input capacitance		-	3.5	-	-	-	-	-	pF

## 10. Dynamic characteristics

**Table 6. Dynamic characteristics**

Voltages are referenced to GND (ground = 0 V);  $C_L = 50$  pF unless otherwise specified; for test circuit, see [Figure 18](#).

Symbol	Parameter	Conditions	25 °C			-40 °C to +85 °C		-40 °C to +125 °C		Unit
			Min	Typ	Max	Min	Max	Min	Max	
<b>74HC40105</b>										
$t_{pd}$	propagation delay	MR to DIR or DOR; see <a href="#">Figure 7</a> <sup>[1]</sup>								
		$V_{CC} = 2.0$ V	-	52	175	-	220	-	265	ns
		$V_{CC} = 4.5$ V	-	19	35	-	44	-	53	ns
		$V_{CC} = 5$ V; $C_L = 15$ pF	-	16	-	-	-	-	-	ns
		$V_{CC} = 6.0$ V	-	15	30	-	37	-	45	ns
		$\overline{SO}$ to Qn; see <a href="#">Figure 10</a> <sup>[1]</sup>								
		$V_{CC} = 2.0$ V	-	116	400	-	500	-	600	ns
		$V_{CC} = 4.5$ V	-	42	80	-	100	-	120	ns
		$V_{CC} = 5$ V; $C_L = 15$ pF	-	37	-	-	-	-	-	ns
$V_{CC} = 6.0$ V	-	34	68	-	85	-	102	ns		
$t_{PHL}$	HIGH to LOW propagation delay	SI to DIR; see <a href="#">Figure 8</a> <sup>[1]</sup>								
		$V_{CC} = 2.0$ V	-	52	210	-	265	-	315	ns
		$V_{CC} = 4.5$ V	-	19	42	-	53	-	63	ns
		$V_{CC} = 5$ V; $C_L = 15$ pF	-	16	-	-	-	-	-	ns
		$V_{CC} = 6.0$ V	-	15	36	-	45	-	54	ns
		$\overline{SO}$ to DOR; see <a href="#">Figure 11</a> <sup>[1]</sup>								
		$V_{CC} = 2.0$ V	-	55	210	-	265	-	315	ns
		$V_{CC} = 4.5$ V	-	20	42	-	53	-	63	ns
		$V_{CC} = 5$ V; $C_L = 15$ pF	-	17	-	-	-	-	-	ns
$V_{CC} = 6.0$ V	-	16	36	-	45	-	54	ns		
$t_{PLH}$	LOW to HIGH propagation delay	SI to DOR; see <a href="#">Figure 14</a> <sup>[1][5]</sup>								
		$V_{CC} = 2.0$ V	-	564	2000	-	2500	-	3000	ns
		$V_{CC} = 4.5$ V	-	205	400	-	500	-	600	ns
		$V_{CC} = 6.0$ V	-	165	340	-	425	-	510	ns
		$\overline{SO}$ to DIR; see <a href="#">Figure 9</a> <sup>[1][6]</sup>								
		$V_{CC} = 2.0$ V	-	701	2500	-	3125	-	3750	ns
		$V_{CC} = 4.5$ V	-	255	500	-	625	-	750	ns
		$V_{CC} = 6.0$ V	-	204	425	-	532	-	638	ns
$t_{en}$	enable time	$\overline{OE}$ to Qn; see <a href="#">Figure 16</a> <sup>[2]</sup>								
		$V_{CC} = 2.0$ V	-	41	150	-	190	-	225	ns
		$V_{CC} = 4.5$ V	-	15	30	-	38	-	45	ns
		$V_{CC} = 6.0$ V	-	12	26	-	33	-	38	ns

**Table 6. Dynamic characteristics ...continued**

Voltages are referenced to GND (ground = 0 V);  $C_L = 50$  pF unless otherwise specified; for test circuit, see [Figure 18](#).

Symbol	Parameter	Conditions	25 °C			-40 °C to +85 °C		-40 °C to +125 °C		Unit
			Min	Typ	Max	Min	Max	Min	Max	
$t_{dis}$	disable time	$\overline{OE}$ to Qn; see <a href="#">Figure 16</a> [3]								
		$V_{CC} = 2.0$ V	-	41	140	-	175	-	210	ns
		$V_{CC} = 4.5$ V	-	15	28	-	35	-	42	ns
		$V_{CC} = 6.0$ V	-	12	24	-	30	-	36	ns
$t_t$	transition time	Qn; see <a href="#">Figure 10</a> [4]								
		$V_{CC} = 2.0$ V	-	19	75	-	95	-	110	ns
		$V_{CC} = 4.5$ V	-	7	15	-	19	-	22	ns
		$V_{CC} = 6.0$ V	-	6	13	-	16	-	19	ns
$t_w$	pulse width	SI HIGH or LOW; see <a href="#">Figure 8</a>								
		$V_{CC} = 2.0$ V	80	19	-	100	-	120	-	ns
		$V_{CC} = 4.5$ V	16	7	-	20	-	24	-	ns
		$V_{CC} = 6.0$ V	14	6	-	17	-	20	-	ns
		SO HIGH or LOW; see <a href="#">Figure 11</a>								
		$V_{CC} = 2.0$ V	120	39	-	150	-	180	-	ns
		$V_{CC} = 4.5$ V	24	14	-	30	-	36	-	ns
		$V_{CC} = 6.0$ V	20	11	-	26	-	31	-	ns
		DIR HIGH; see <a href="#">Figure 9</a>								
		$V_{CC} = 2.0$ V	12	58	180	10	225	10	270	ns
		$V_{CC} = 4.5$ V	6	21	36	5	45	5	54	ns
		$V_{CC} = 6.0$ V	5	17	31	4	38	4	46	ns
		DOR LOW; see <a href="#">Figure 14</a>								
		$V_{CC} = 2.0$ V	12	55	170	10	215	10	255	ns
		$V_{CC} = 4.5$ V	6	20	34	5	43	5	51	ns
		$V_{CC} = 6.0$ V	5	16	29	4	37	4	43	ns
MR HIGH; see <a href="#">Figure 7</a>										
$V_{CC} = 2.0$ V	80	22	-	100	-	120	-	ns		
$V_{CC} = 4.5$ V	16	8	-	20	-	24	-	ns		
$V_{CC} = 6.0$ V	14	6	-	17	-	20	-	ns		
$t_{rec}$	recovery time	MR to SI; see <a href="#">Figure 15</a>								
		$V_{CC} = 2.0$ V	50	14	-	65	-	75	-	ns
		$V_{CC} = 4.5$ V	10	5	-	13	-	15	-	ns
		$V_{CC} = 6.0$ V	9	4	-	11	-	13	-	ns
$t_{su}$	set-up time	Dn to SI; see <a href="#">Figure 17</a>								
		$V_{CC} = 2.0$ V	-5	-39	-	-5	-	-5	-	ns
		$V_{CC} = 4.5$ V	-5	-14	-	-5	-	-5	-	ns
		$V_{CC} = 6.0$ V	-5	-11	-	-5	-	-5	-	ns

**Table 6. Dynamic characteristics ...continued**

Voltages are referenced to GND (ground = 0 V);  $C_L = 50$  pF unless otherwise specified; for test circuit, see [Figure 18](#).

Symbol	Parameter	Conditions	25 °C			−40 °C to +85 °C		−40 °C to +125 °C		Unit
			Min	Typ	Max	Min	Max	Min	Max	
$t_h$	hold time	Dn to SI; see <a href="#">Figure 17</a>								
		$V_{CC} = 2.0$ V	125	44	-	155	-	190	-	ns
		$V_{CC} = 4.5$ V	25	16	-	31	-	38	-	ns
		$V_{CC} = 6.0$ V	21	13	-	26	-	32	-	ns
$f_{max}$	maximum frequency	SI, $\overline{SO}$ using flags or burst mode; see <a href="#">Figure 8</a> and <a href="#">Figure 11</a> ; see <a href="#">Figure 12</a> and <a href="#">Figure 13</a>								
		$V_{CC} = 2.0$ V	3.6	10	-	2.8	-	2.4	-	MHz
		$V_{CC} = 4.5$ V	18	30	-	14	-	12	-	MHz
		$V_{CC} = 5$ V; $C_L = 15$ pF	-	33	-	-	-	-	-	MHz
		$V_{CC} = 6.0$ V	21	36	-	16	-	14	-	MHz
		SI, $\overline{SO}$ cascaded; see <a href="#">Figure 8</a> and <a href="#">Figure 11</a>								
		$V_{CC} = 2.0$ V	3.6	10	-	2.8	-	2.4	-	MHz
		$V_{CC} = 4.5$ V	18	30	-	14	-	12	-	MHz
$V_{CC} = 6.0$ V	21	36	-	16	-	14	-	MHz		
$C_{PD}$	power dissipation capacitance	$V_I = \text{GND to } V_{CC}$	<a href="#">[7]</a>	-	134	-	-	-	-	pF

**Table 6. Dynamic characteristics ...continued**

Voltages are referenced to GND (ground = 0 V);  $C_L = 50$  pF unless otherwise specified; for test circuit, see [Figure 18](#).

Symbol	Parameter	Conditions	25 °C			-40 °C to +85 °C		-40 °C to +125 °C		Unit
			Min	Typ	Max	Min	Max	Min	Max	
<b>74HCT40105</b>										
$t_{pd}$	propagation delay	MR to DIR or DOR; see <a href="#">Figure 7</a> <sup>[1]</sup>								
		$V_{CC} = 4.5$ V	-	18	35	-	44	-	53	ns
		$V_{CC} = 5$ V; $C_L = 15$ pF	-	15	-	-	-	-	-	ns
		$\overline{SO}$ to Qn; see <a href="#">Figure 10</a> <sup>[1]</sup>								
		$V_{CC} = 4.5$ V	-	40	80	-	100	-	120	ns
		$V_{CC} = 5$ V; $C_L = 15$ pF	-	35	-	-	-	-	ns	
$t_{PHL}$	HIGH to LOW propagation delay	SI to DIR; see <a href="#">Figure 8</a> <sup>[1]</sup>								
		$V_{CC} = 4.5$ V	-	21	42	-	53	-	63	ns
		$V_{CC} = 5$ V; $C_L = 15$ pF	-	18	-	-	-	-	-	ns
		$\overline{SO}$ to DOR; see <a href="#">Figure 11</a> <sup>[1]</sup>								
		$V_{CC} = 4.5$ V	-	20	42	-	53	-	63	ns
		$V_{CC} = 5$ V; $C_L = 15$ pF	-	18	-	-	-	-	ns	
$t_{PLH}$	LOW to HIGH propagation delay	SI to DOR; see <a href="#">Figure 14</a> <sup>[1][5]</sup>								
		$V_{CC} = 4.5$ V	-	188	400	-	500	-	600	ns
		$\overline{SO}$ to DIR; see <a href="#">Figure 9</a> <sup>[1][6]</sup>								
		$V_{CC} = 4.5$ V	-	244	500	-	625	-	750	ns
$t_{en}$	enable time	$\overline{OE}$ to Qn; see <a href="#">Figure 16</a> <sup>[2]</sup>								
		$V_{CC} = 4.5$ V	-	18	35	-	44	-	53	ns
$t_{dis}$	disable time	$\overline{OE}$ to Qn; see <a href="#">Figure 16</a> <sup>[3]</sup>								
		$V_{CC} = 4.5$ V	-	15	30	-	38	-	45	ns
$t_t$	transition time	Qn; see <a href="#">Figure 10</a> <sup>[4]</sup>								
		$V_{CC} = 4.5$ V	-	7	15	-	19	-	22	ns
$t_W$	pulse width	SI HIGH or LOW; see <a href="#">Figure 8</a>								
		$V_{CC} = 4.5$ V	16	6	-	20	-	24	-	ns
		$\overline{SO}$ HIGH or LOW; see <a href="#">Figure 11</a>								
		$V_{CC} = 4.5$ V	16	7	-	20	-	24	-	ns
		DIR HIGH; see <a href="#">Figure 9</a>								
		$V_{CC} = 4.5$ V	6	20	34	5	43	5	51	ns
		DOR LOW; see <a href="#">Figure 14</a>								
		$V_{CC} = 4.5$ V	6	19	34	5	43	5	51	ns
$t_{rec}$	recovery time	MR HIGH; see <a href="#">Figure 7</a>								
		$V_{CC} = 4.5$ V	16	7	-	20	-	24	-	ns
		MR to SI; see <a href="#">Figure 15</a>								
		$V_{CC} = 4.5$ V	15	7	-	19	-	22	-	ns

**Table 6. Dynamic characteristics ...continued**

Voltages are referenced to GND (ground = 0 V);  $C_L = 50$  pF unless otherwise specified; for test circuit, see [Figure 18](#).

Symbol	Parameter	Conditions	25 °C			-40 °C to +85 °C		-40 °C to +125 °C		Unit
			Min	Typ	Max	Min	Max	Min	Max	
$t_{su}$	set-up time	Dn to SI; see <a href="#">Figure 17</a>								
		$V_{CC} = 4.5$ V	-5	-14	-	-4	-	-4	-	ns
$t_h$	hold time	Dn to SI; see <a href="#">Figure 17</a>								
		$V_{CC} = 4.5$ V	27	16	-	34	-	41	-	ns
$f_{max}$	maximum frequency	SI, $\overline{SO}$ using flags or burst mode; see <a href="#">Figure 8</a> and <a href="#">Figure 11</a> ; see <a href="#">Figure 12</a> and <a href="#">Figure 13</a>								
		$V_{CC} = 4.5$ V	-	28	-	12	-	10	-	MHz
		$V_{CC} = 5$ V; $C_L = 15$ pF	-	31	-	-	-	-	-	MHz
		SI, $\overline{SO}$ cascaded; see <a href="#">Figure 8</a> and <a href="#">Figure 11</a>								
$C_{PD}$	power dissipation capacitance	$V_I = GND$ to $V_{CC} - 1.5$ V <a href="#">[7]</a>	-	145	-	-	-	-	-	pF

- [1]  $t_{pd}$  is the same as  $t_{PLH}$  and  $t_{PHL}$ .
- [2]  $t_{en}$  is the same as  $t_{PZH}$  and  $t_{PZL}$ .
- [3]  $t_{dis}$  is the same as  $t_{PLZ}$  and  $t_{PHZ}$ .
- [4]  $t_t$  is the same as  $t_{THL}$  and  $t_{TLH}$ .
- [5] This is the ripple through delay.
- [6] This is the bubble-up delay.
- [7]  $C_{PD}$  is used to determine the dynamic power dissipation ( $P_D$  in  $\mu W$ ).  
 $P_D = C_{PD} \times V_{CC}^2 \times f_i \times N + \sum(C_L \times V_{CC}^2 \times f_o)$  where:  
 $f_i$  = input frequency in MHz;  
 $f_o$  = output frequency in MHz;  
 $C_L$  = output load capacitance in pF;  
 $V_{CC}$  = supply voltage in V;  
 $N$  = number of inputs switching;  
 $\sum(C_L \times V_{CC}^2 \times f_o)$  = sum of outputs.

## 11. Waveforms

### 11.1 Master reset applied with FIFO full

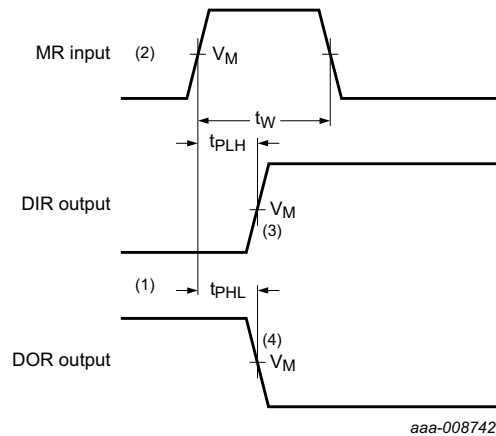

Measurement points are given in [Table 7](#).

$V_{OL}$  and  $V_{OH}$  are typical voltage output levels that occur with the output load.

- (1) DIR LOW; output ready HIGH; assume that FIFO is full
- (2) MR pulse HIGH; clears FIFO
- (3) DIR goes HIGH; flag indicates input prepared for valid data
- (4) DOR goes LOW; flag indicates FIFO empty

**Fig 7. Propagation delay MR input to DIR output, DOR output and Qn outputs and the MR pulse width.**

11.2 Shifting in sequence FIFO empty to FIFO full

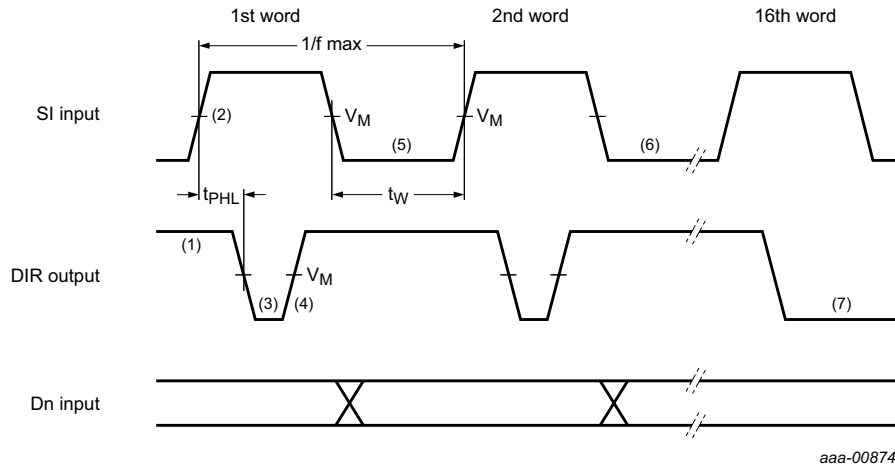

Measurement points are given in [Table 7](#).

$V_{OL}$  and  $V_{OH}$  are typical voltage output levels that occur with the output load.

- (1) DIR initially HIGH; FIFO is prepared for valid data
- (2) SI set HIGH; data loaded into input stage
- (3) DIR drops LOW; input stage “busy”
- (4) DIR goes HIGH; status flag indicates FIFO prepared for additional data
- (5) SI set LOW; data from first location “ripple through”
- (6) To load 2<sup>nd</sup> word through to 16<sup>th</sup> word into FIFO, repeat the process.
- (7) DIR remains LOW; with attempt to shift into full FIFO, no data transfer occurs.

**Fig 8. Propagation delay SI input to DIR output, the SI pulse width and the SI maximum frequency**

**Table 7. Measurement points**

Type	Input	Output		
	$V_M$	$V_M$	$V_X$	$V_Y$
74HC40105	$0.5V_{CC}$	$0.5V_{CC}$	$0.1V_{CC}$	$0.9V_{CC}$
74HCT40105	1.3 V	1.3 V	$0.1V_{CC}$	$0.9V_{CC}$



11.3 With FIFO full; SI held HIGH in anticipation of empty location

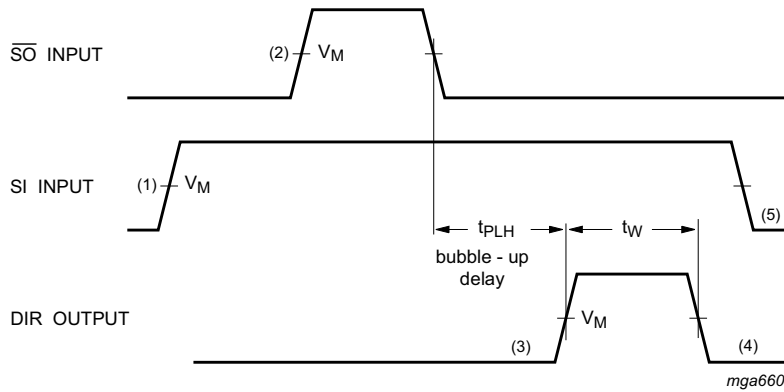

Measurement points are given in [Table 7](#).

$V_{OL}$  and  $V_{OH}$  are typical voltage output levels that occur with the output load.

- (1) FIFO is initially full, shift-in is held HIGH
- (2)  $\overline{SO}$  pulse; data in output stage is unloaded, “bubble-up” process of empty location begins
- (3) DIR HIGH; when empty location reaches input stage, flag indicates that FIFO is prepared for data input
- (4) DIR returns to LOW; data shift-in to empty location is complete, FIFO is full again
- (5) SI set LOW; necessary to complete shift-in process, DIR remains LOW, because FIFO is full

Fig 9. Bubble-up delay  $\overline{SO}$  input to DIR output, the DIR pulse width.

11.4  $\overline{SO}$  input to Qn outputs propagation delay

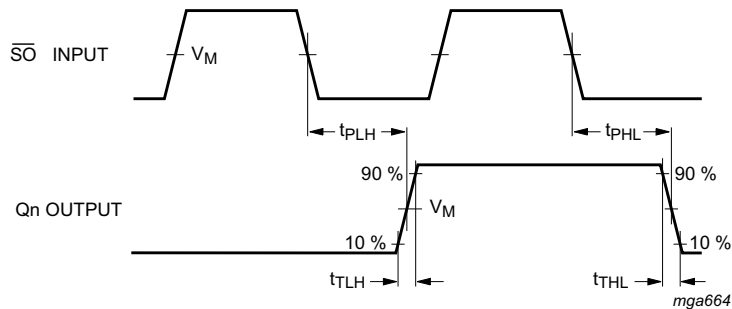

Measurement points are given in [Table 7](#).

$V_{OL}$  and  $V_{OH}$  are typical voltage output levels that occur with the output load.

Fig 10. Propagation delay  $\overline{SO}$  input to Qn outputs and the output transition time

11.5 Shifting out sequence; FIFO full to FIFO empty

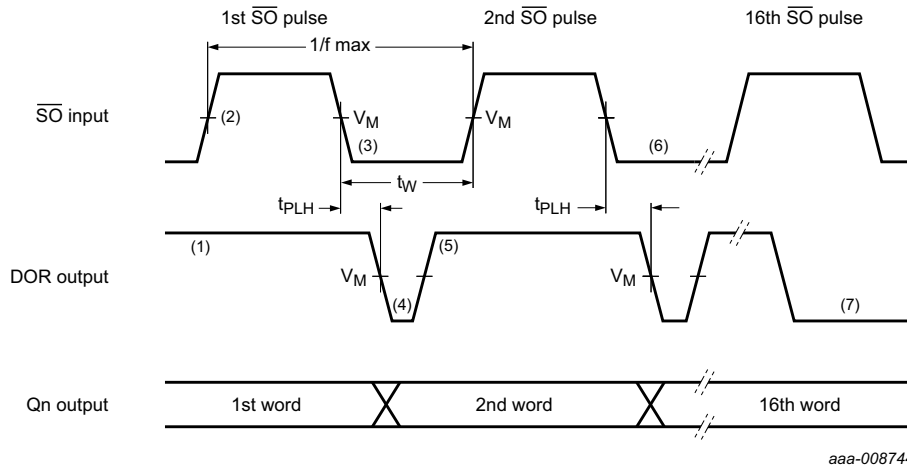

- Measurement points are given in [Table 7](#).  
 $V_{OL}$  and  $V_{OH}$  are typical voltage output levels that occur with the output load.
- (1) DOR HIGH; no data transfer in progress, valid data is present at the output stage
  - (2)  $\overline{S_O}$  set HIGH; result in DOR going LOW
  - (3)  $\overline{S_O}$  set LOW; data in the input stage is unloaded, and new data replaces it as empty location “bubbles-up” to input stage
  - (4) DOR drops LOW; output stage “busy”
  - (5) DOR goes HIGH; transfer process completed, valid data present at output after the specified propagation delay
  - (6) To unload the 3<sup>rd</sup> through the 16<sup>th</sup> word from FIFO, repeat the process
  - (7) DOR remains LOW; FIFO is empty

Fig 11. Propagation delay  $\overline{S_O}$  input to DOR output, the  $\overline{S_O}$  pulse width and the  $\overline{S_O}$  maximum frequency.

11.6 Shift-in operation; high-speed burst mode

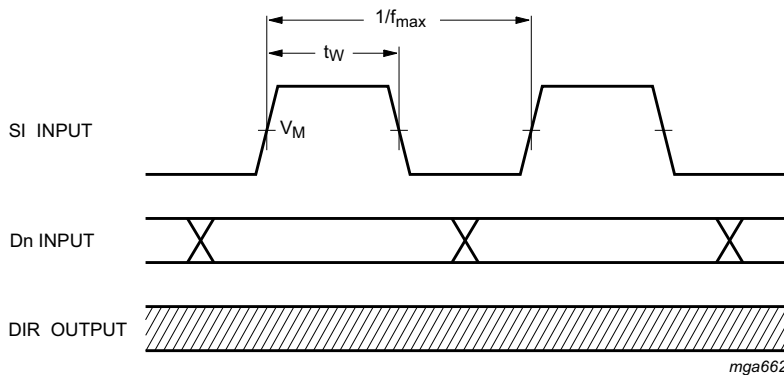

Measurement points are given in [Table 7](#).  
 $V_{OL}$  and  $V_{OH}$  are typical voltage output levels that occur with the output load.

In the high-speed mode, the minimum shift-in HIGH and shift-in LOW specifications determines the burst-in rate. The DIR status flag is a “don’t care” condition, and a shift-in pulse can be applied regardless of the flag. An SI pulse which would overflow the storage capacity of the FIFO is ignored.

Fig 12. The SI pulse width and the SI maximum frequency, in high-speed shift-in burst mode

11.7 Shift-out operation; high-speed burst mode

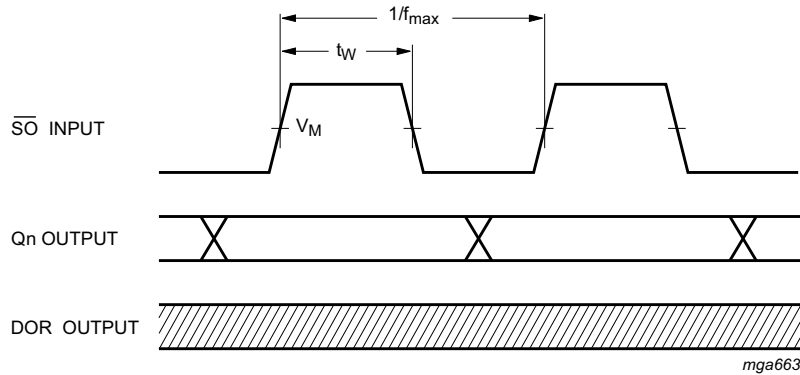

Measurement points are given in [Table 7](#).

$V_{OL}$  and  $V_{OH}$  are typical voltage output levels that occur with the output load.

In the high-speed mode, the minimum shift-out HIGH and shift-out LOW specifications determine the burst-out rate. The DOR flag is a “don't care” condition, and an  $\overline{SO}$  pulse can be applied without regard to the flag.

**Fig 13. The  $\overline{SO}$  pulse width and the  $\overline{SO}$  maximum frequency, in high-speed shift-out burst mode**

### 11.8 With FIFO empty; $\overline{S\bar{O}}$ is held HIGH in anticipation

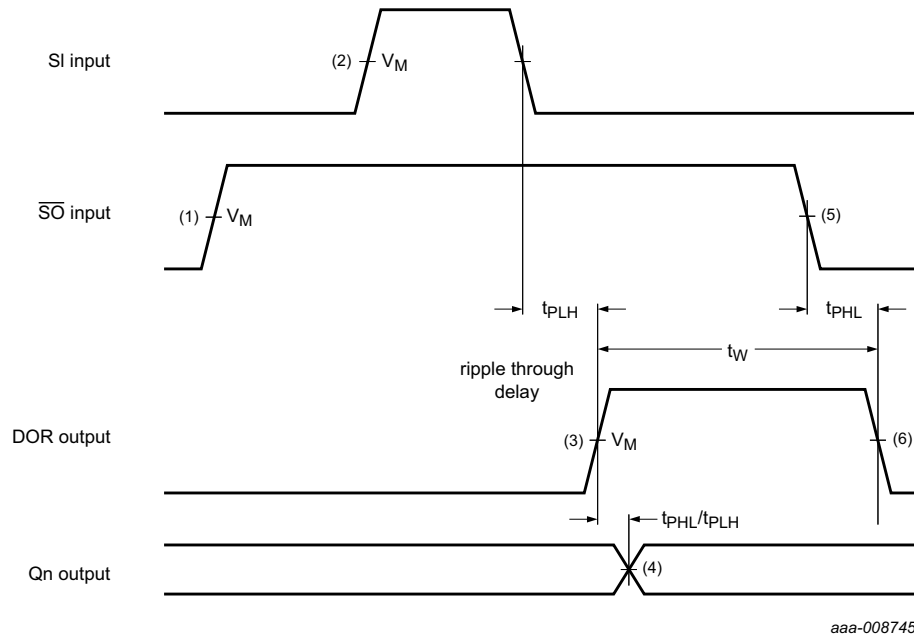

Measurement points are given in [Table 7](#).

$V_{OL}$  and  $V_{OH}$  are typical voltage output levels that occur with the output load.

- (1) FIFO is initially empty.  $\overline{S\bar{O}}$  is held HIGH.
- (2) SI pulse; loads data into FIFO and initiates ripple through process
- (3) Output transition; data arrives at output stage after the specified propagation delay between the rising and falling edge of the DOR pulse to the Qn output
- (4) DOR flag signals the arrival of valid data at the output stage
- (5)  $\overline{S\bar{O}}$  set LOW; necessary to complete shift-out process. DOR remains LOW, because FIFO is empty
- (6) DOR goes LOW; data shift-out is completed, FIFO is empty again

**Fig 14. Ripple through delay SI input to DOR output, propagation delay DOR input to Qn outputs and the DOR pulse width**

11.9 MR to SI recovery time

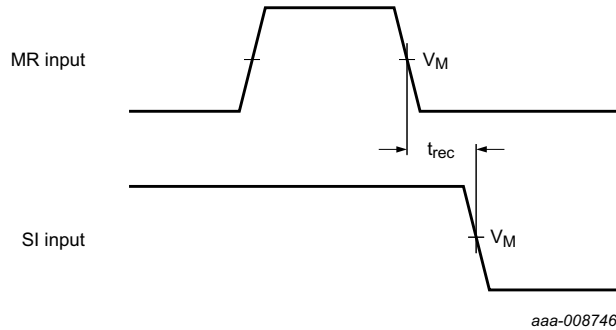

Measurement points are given in [Table 7](#).

$V_{OL}$  and  $V_{OH}$  are typical voltage output levels that occur with the output load.

Fig 15. MR to SI recovery time

11.10 Enable and disable times

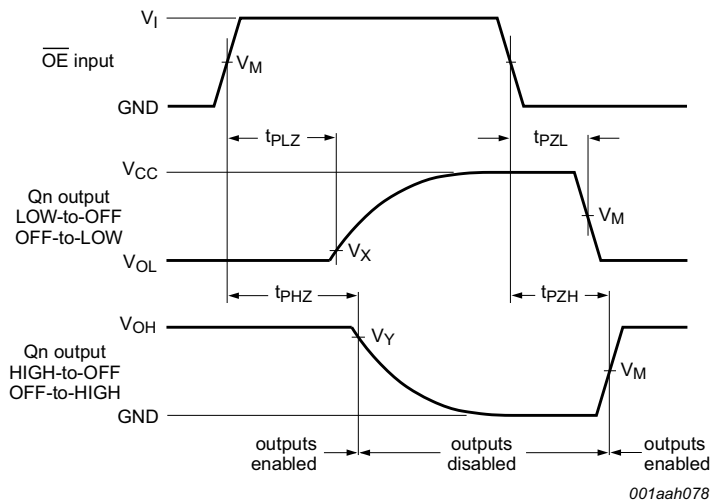

Measurement points are given in [Table 7](#).

$V_{OL}$  and  $V_{OH}$  are typical voltage output levels that occur with the output load.

Fig 16. Enable and disable times

11.11 Set-up and hold times

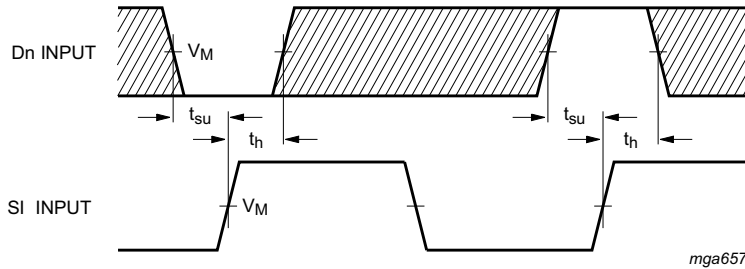

Measurement points are given in [Table 7](#).

$V_{OL}$  and  $V_{OH}$  are typical voltage output levels that occur with the output load.

The shaded areas indicate when the output is permitted to change for predictable output performance

Fig 17. Set-up and hold times

11.12 Test circuit for measuring switching times

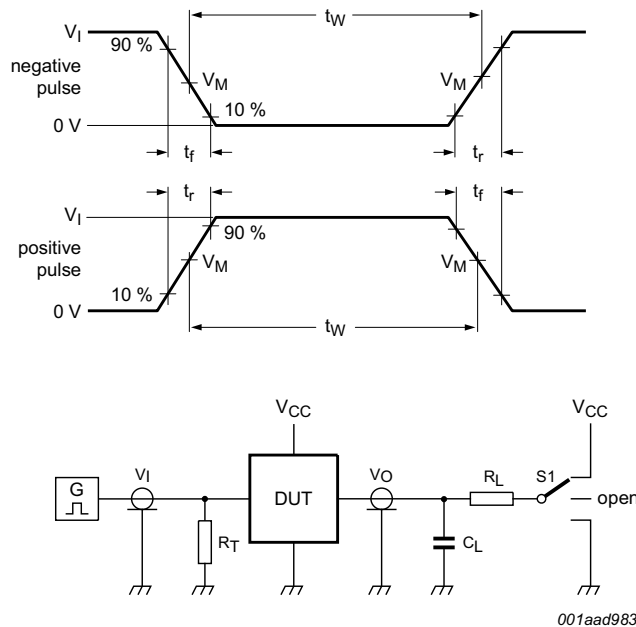

Test data is given in [Table 8](#).

Definitions test circuit:

$R_T$  = Termination resistance should be equal to output impedance  $Z_o$  of the pulse generator.

$C_L$  = Load capacitance including jig and probe capacitance.

$R_L$  = Load resistance.

S1 = Test selection switch.

Fig 18. Test circuit for measuring switching times

**Table 8. Test data**

Type	Input		Load		S1 position		
	V <sub>I</sub>	t <sub>r</sub> , t <sub>f</sub>	C <sub>L</sub>	R <sub>L</sub>	t <sub>PHL</sub> , t <sub>PLH</sub>	t <sub>PZH</sub> , t <sub>PHZ</sub>	t <sub>PZL</sub> , t <sub>PLZ</sub>
74HC40105	V <sub>CC</sub>	6 ns	15 pF, 50 pF	1 kΩ	open	GND	V <sub>CC</sub>
74HCT40105	3 V	6 ns	15 pF, 50 pF	1 kΩ	open	GND	V <sub>CC</sub>

## 12. Application information

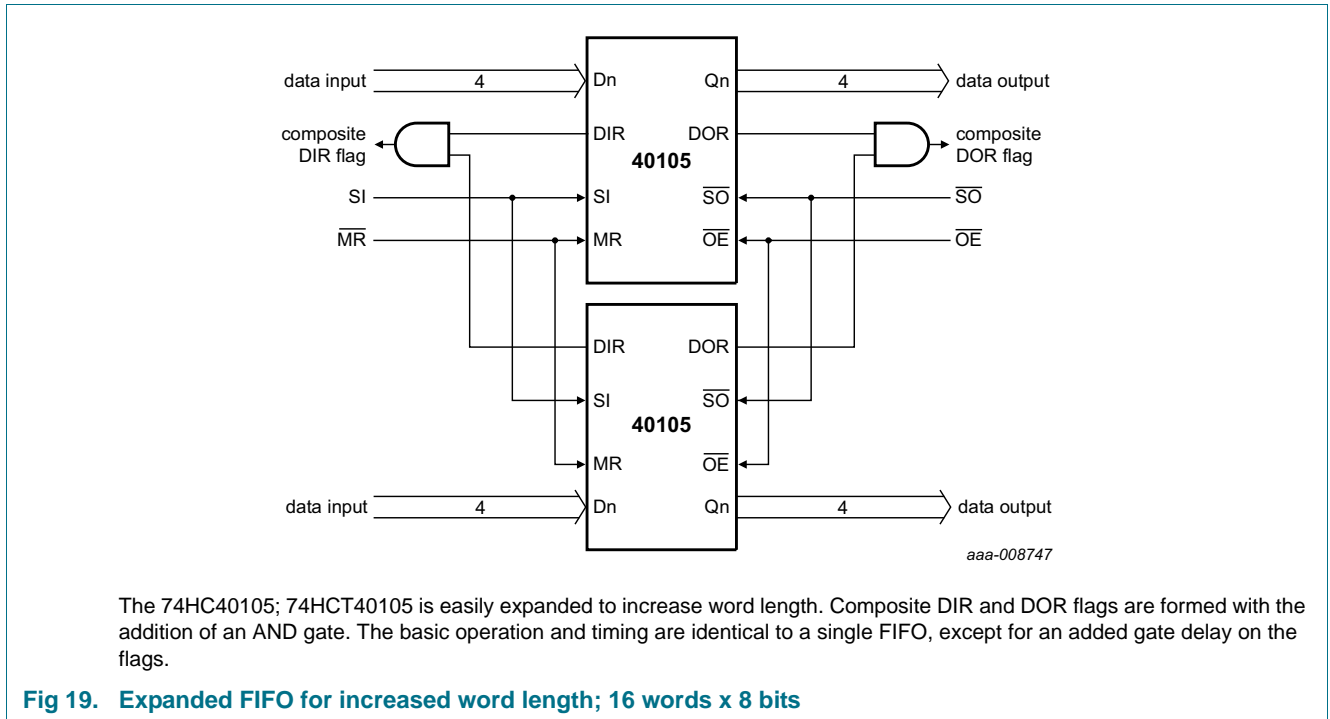

The 74HC40105; 74HCT40105 is easily expanded to increase word length. Composite DIR and DOR flags are formed with the addition of an AND gate. The basic operation and timing are identical to a single FIFO, except for an added gate delay on the flags.

**Fig 19. Expanded FIFO for increased word length; 16 words x 8 bits**

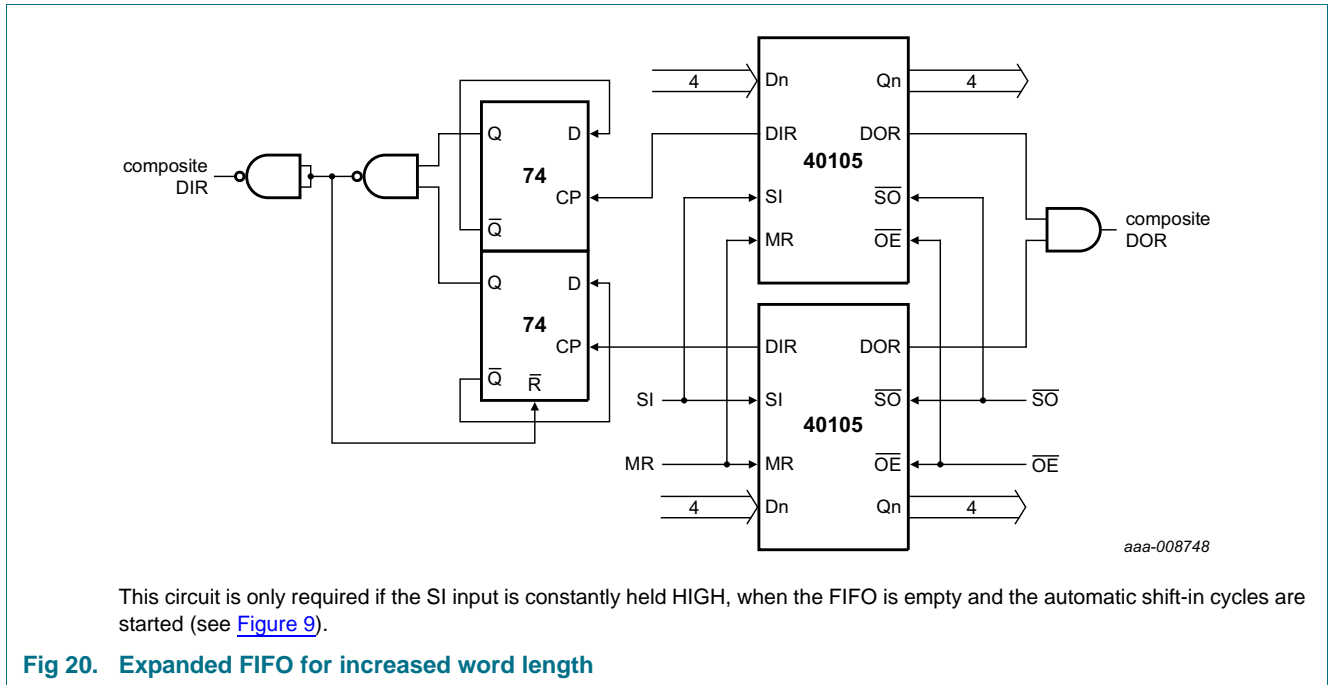

### 12.1 Expanded format

[Figure 21](#) shows two cascaded FIFOs providing a capacity of 32 words x 4 bits. [Figure 22](#) shows the signals on the nodes of both FIFOs after the application of the SI pulse, when both FIFOs are initially empty. After a ripple through delay, data arrives at the output of FIFOA. Due to  $\overline{SOA}$  being HIGH, a DORA pulse is generated. The DORA pulse width and the timing between the rising edge of DORA and QnA satisfy the requirements of SIB and DnB. After a second ripple through delay data arrives at the output of FIFOB.

[Figure 23](#) shows the signals on the nodes of both FIFOs after the application of the  $\overline{SOB}$  pulse, when both FIFOs are initially full. After a bubble-up delay, a DIRB pulse is generated, which acts as a  $\overline{SOA}$  pulse for FIFOA. One word is transferred from the output of FIFOA to the input of FIFOB. The pulse width of DORB satisfy the requirements of the  $\overline{SOA}$  pulse for FIFOA. After a second bubble-up delay, an empty space arrives at DnA, at which time DIRA goes HIGH. [Figure 24](#) shows the waveforms at all external nodes of both FIFOs during a complete shift-in and shift-out sequence.



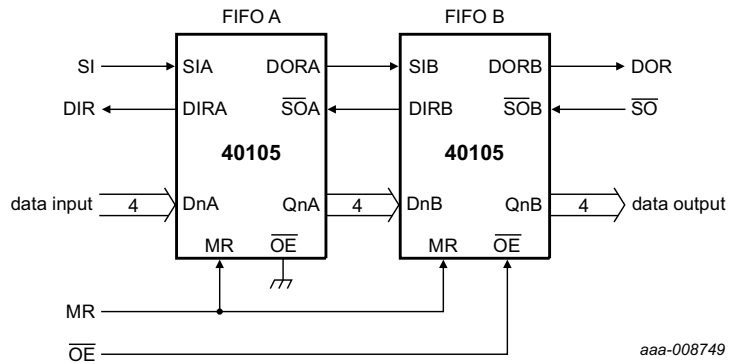

The 74HC40105; 74HCT40105 is easily cascaded to increase word capacity without external circuitry. In cascaded format, the FIFOs handle all necessary communications. [Figure 19](#) and [Figure 21](#) demonstrate the communication timing between FIFOA and FIFOB. [Figure 24](#) provides an overview of pulses and timing of two cascaded FIFOs, when shifted full and shifted empty again.

**Fig 21. Cascading for increased word capacity; 32 words x 4 bits**

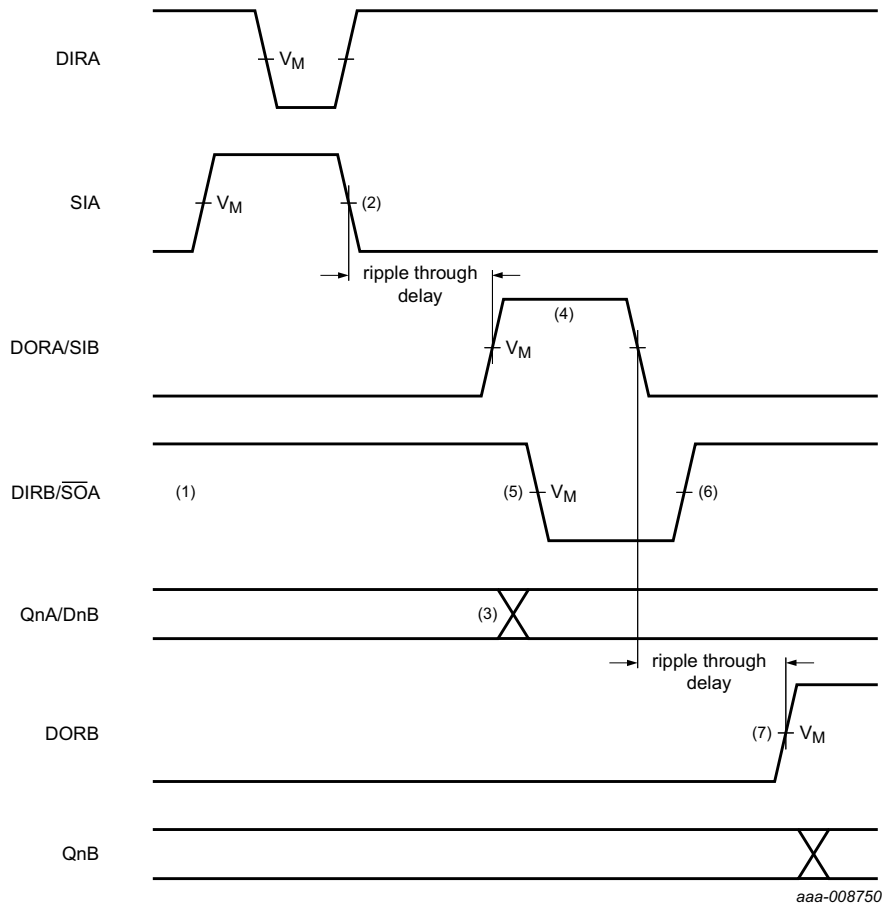

- (1) FIFOA and FIFOB are initially empty,  $\overline{SOA}$  held HIGH in anticipation of data
- (2) Load one word into FIFOA; SI pulse; applied. results in DIR pulse
- (3) Data-out A/ data-in B transition; valid data arrives at FIFOA output stage after a specified delay of the DOR flag, meeting data input set-up requirements of FIFOB.
- (4) DORA and SIB pulse HIGH; (ripple through delay after SIA LOW) data is unloaded from FIFOA as a result of the data output ready pulse, data is shifted into FIFOB
- (5) DIRB and  $\overline{SOA}$  go LOW; flag indicates that input stage of FIFOB is busy, shift-out of FIFOA is complete
- (6)  $\overline{DIRB}$  and  $\overline{SOA}$  go HIGH automatically; the input stage of FIFOB is again able to receive data, SO is held HIGH in anticipation of additional data
- (7)  $\overline{DORB}$  goes HIGH; (ripple through delay after SIB LOW) valid data is present one propagation delay later at the FIFOB output stage

**Fig 22. FIFO to FIFO communication; input timing under empty condition**

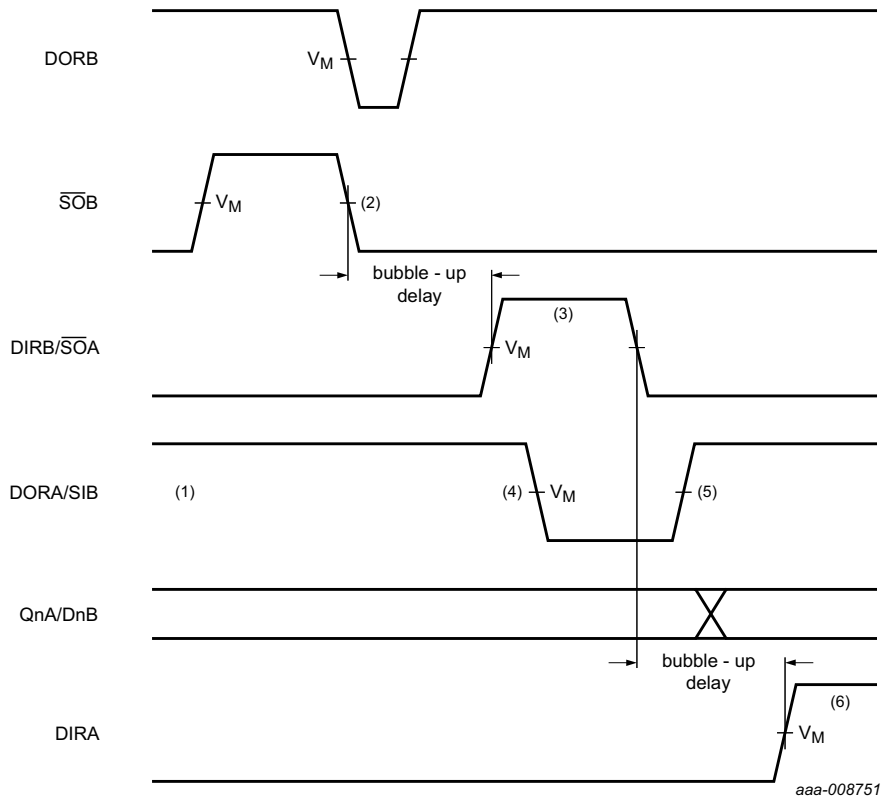

- (1) FIFOA and FIFOB initially empty, SIB held HIGH in anticipation of shifting in new data as an empty location bubbles-up
- (2) Unload one word from FIFOB;  $\overline{SO}$  pulse applied, results in DOR pulse
- (3) DIRB and SOA pulse HIGH; (bubble-up delay after SOB LOW) data is loaded into FIFOB as a result of the DIR pulse, data is shifted out of FIFOA
- (4) DORA and SIB go LOW; flag indicates that the output stage of FIFOA is busy, shift-in of FIFOB is complete
- (5) DORA and SIB go HIGH; flag indicates that valid data is again available at FIFOA output stage, SIB is held HIGH, awaiting bubble-up of empty location.
- (6) DIRA goes HIGH; (bubble-up delay after SOA LOW) an empty location is present at input stage of FIFOA

**Fig 23. FIFO to FIFO communication; output timing under full condition**

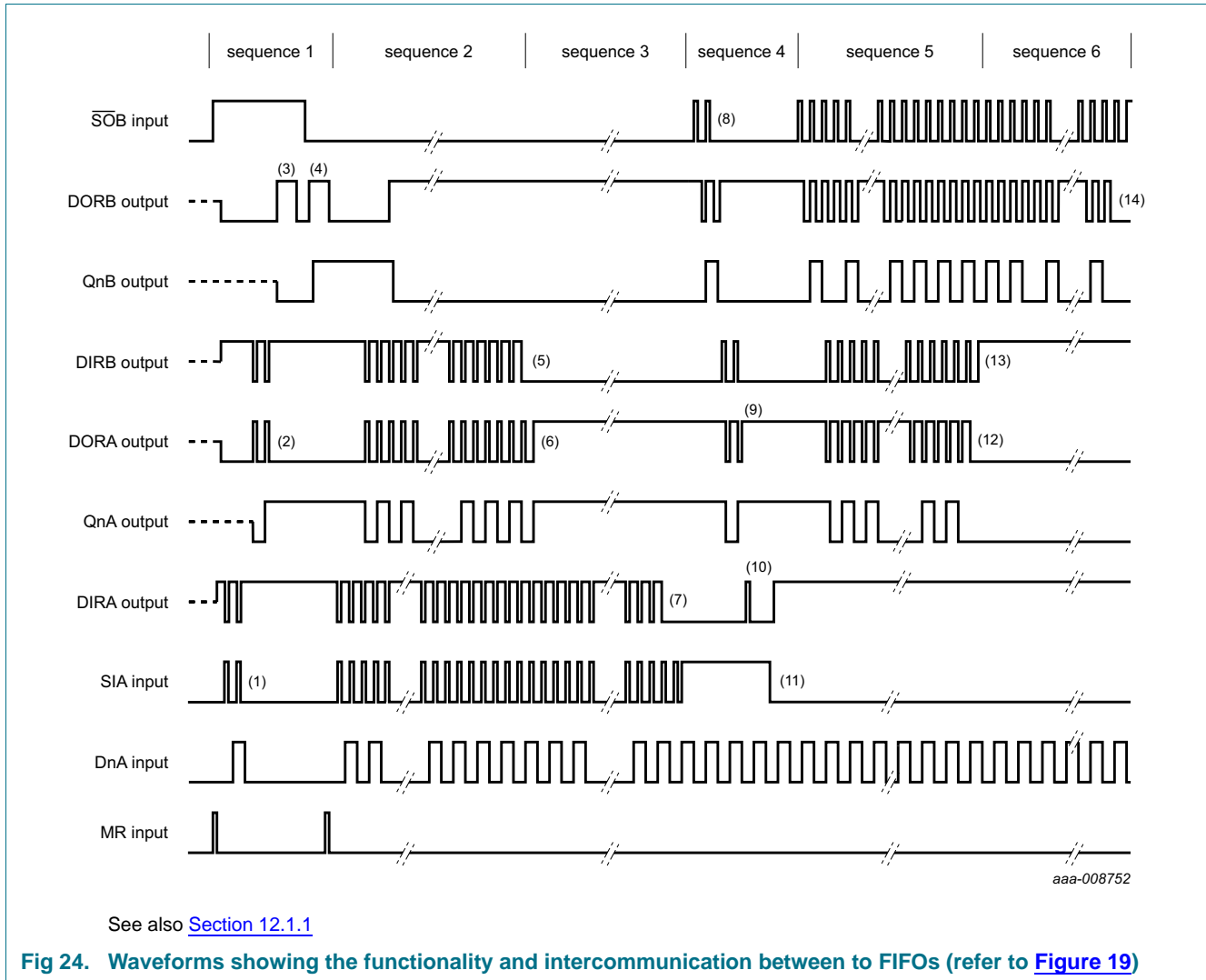

**12.1.1 Sequence 1 (both FIFOs empty, starting SHIFT-IN process)**

After an MR pulse has been applied, FIFOA and FIFOB are empty. The DOR flags of FIFOA and FIFOB go LOW due to no valid data being present at the outputs. The DIR flags are set HIGH due to the FIFOs being ready to accept data.  $\overline{SÖB}$  is held HIGH and two SIA pulses are applied (1). These pulses allow two data words to ripple through the output stage of FIFOA and the input stage of FIFOB (2). When data arrives at the output of FIFOB, a DORB pulse is generated (3). When  $\overline{SÖB}$  goes LOW, the first bit is shifted out and a second bit ripples through to the output after which DORB goes high (4).

**12.1.2 Sequence 2 (FIFOB runs full)**

After the MR pulse, a series of 16 SI pulses are applied. When 16 words are shifted in, DIRB remains LOW due to FIFOB being full (5). DORA goes LOW due to FIFOA being empty.

### 12.1.3 Sequence 3 (FIFOA runs full)

When 17 words are shifted in, DORA remains HIGH due to valid data remaining at the output of FIFOA. QnA remains HIGH, being the polarity of the 17<sup>th</sup> word (6). After the 32<sup>th</sup> SI pulse, DIR remains LOW and both FIFOs are full (7). Additional pulses have no effect.

### 12.1.4 Sequence 4 (both FIFOs full, starting SHIFT-OUT)

SIA is held HIGH and two  $\overline{\text{SOB}}$  pulses are applied (8). These pulses shift out two words and thus allow two empty locations to bubble-up to the input stage of FIFOB, and proceed to FIFOA (9). When the first empty location arrives at the input of FIFOA, a DIRA pulse is generated (10) and a new word is shifted into FIFOA. SIA is made LOW and now the second empty location reaches the input stage of FIFOA, after which DIRA remains HIGH (11).

### 12.1.5 Sequence 5 (FIFOA runs empty)

At the start of sequence 5, FIFOA contains 15 valid words due to two words being shifted out and one word being shifted in, in sequence 4. And additional series of  $\overline{\text{SOB}}$  pulses are applied. After 15  $\overline{\text{SOB}}$  pulses, all words from FIFOA are shifted in FIFOB. DORA remains LOW (12).

### 12.1.6 Sequence 6 (FIFOB runs empty)

After the next  $\overline{\text{SOB}}$  pulse, DIRB remains HIGH due to the input stage of FIFOB being empty (13). After another 15  $\overline{\text{SOB}}$  pulses, DORB remains LOW due to both FIFOS being empty (14). Additional  $\overline{\text{SOB}}$  pulses have no effect. The last word remains available at the output Qn.

13. Package outline

SO16: plastic small outline package; 16 leads; body width 3.9 mm

SOT109-1



Fig 25. Package outline SOT109-1 (SO16)

SSOP16: plastic shrink small outline package; 16 leads; body width 5.3 mm

SOT338-1



Fig 26. Package outline SOT338-1 (SO16)

TSSOP16: plastic thin shrink small outline package; 16 leads; body width 4.4 mm

SOT403-1



Fig 27. Package outline SOT403-1 (SO16)



## 14. Abbreviations

Table 9. Abbreviations

Acronym	Description
CMOS	Complementary Metal Oxide Semiconductor
ESD	ElectroStatic Discharge
HBM	Human Body Model
MM	Machine Model
TTL	Transistor-Transistor Logic
FIFO	First In First Out

## 15. Revision history

Table 10. Revision history

Document ID	Release date	Data sheet status	Change notice	Supersedes
74HC_HCT40105 v. 4	20160129	Product data sheet	-	74HC_HCT40105 v. 3
Modifications:	<ul style="list-style-type: none"> <li>Type numbers 74HC40105N and 74HCT40105N (SOT38-4) removed.</li> </ul>			
74HC_HCT40105 v. 3	20130925	Product data sheet	-	74HC_HCT40105_CNV v.2
Modifications:	<ul style="list-style-type: none"> <li>The format of this data sheet has been redesigned to comply with the new identity guidelines of NXP Semiconductors.</li> <li>Legal texts have been adapted to the new company name where appropriate.</li> </ul>			
74HC_HCT40105_CNV v.2	19980123	Product specification	-	-

## 16. Legal information

### 16.1 Data sheet status

Document status <sup>[1][2]</sup>	Product status <sup>[3]</sup>	Definition
Objective [short] data sheet	Development	This document contains data from the objective specification for product development.
Preliminary [short] data sheet	Qualification	This document contains data from the preliminary specification.
Product [short] data sheet	Production	This document contains the product specification.

[1] Please consult the most recently issued document before initiating or completing a design.

[2] The term 'short data sheet' is explained in section "Definitions".

[3] The product status of device(s) described in this document may have changed since this document was published and may differ in case of multiple devices. The latest product status information is available on the Internet at URL <http://www.nexperia.com>.

### 16.2 Definitions

**Draft** — The document is a draft version only. The content is still under internal review and subject to formal approval, which may result in modifications or additions. Nexperia does not give any representations or warranties as to the accuracy or completeness of information included herein and shall have no liability for the consequences of use of such information.

**Short data sheet** — A short data sheet is an extract from a full data sheet with the same product type number(s) and title. A short data sheet is intended for quick reference only and should not be relied upon to contain detailed and full information. For detailed and full information see the relevant full data sheet, which is available on request via the local Nexperia sales office. In case of any inconsistency or conflict with the short data sheet, the full data sheet shall prevail.

**Product specification** — The information and data provided in a Product data sheet shall define the specification of the product as agreed between Nexperia and its customer, unless Nexperia and customer have explicitly agreed otherwise in writing. In no event however, shall an agreement be valid in which the Nexperia product is deemed to offer functions and qualities beyond those described in the Product data sheet.

### 16.3 Disclaimers

**Limited warranty and liability** — Information in this document is believed to be accurate and reliable. However, Nexperia does not give any representations or warranties, expressed or implied, as to the accuracy or completeness of such information and shall have no liability for the consequences of use of such information. Nexperia takes no responsibility for the content in this document if provided by an information source outside of Nexperia.

In no event shall Nexperia be liable for any indirect, incidental, punitive, special or consequential damages (including - without limitation - lost profits, lost savings, business interruption, costs related to the removal or replacement of any products or rework charges) whether or not such damages are based on tort (including negligence), warranty, breach of contract or any other legal theory.

Notwithstanding any damages that customer might incur for any reason whatsoever, Nexperia's aggregate and cumulative liability towards customer for the products described herein shall be limited in accordance with the *Terms and conditions of commercial sale* of Nexperia.

**Right to make changes** — Nexperia reserves the right to make changes to information published in this document, including without limitation specifications and product descriptions, at any time and without notice. This document supersedes and replaces all information supplied prior to the publication hereof.

**Suitability for use** — Nexperia products are not designed, authorized or warranted to be suitable for use in life support, life-critical or safety-critical systems or equipment, nor in applications where failure or malfunction of a Nexperia product can reasonably be expected to result in personal injury, death or severe property or environmental damage. Nexperia and its suppliers accept no liability for inclusion and/or use of Nexperia products in such equipment or applications and therefore such inclusion and/or use is at the customer's own risk.

**Applications** — Applications that are described herein for any of these products are for illustrative purposes only. Nexperia makes no representation or warranty that such applications will be suitable for the specified use without further testing or modification.

Customers are responsible for the design and operation of their applications and products using Nexperia products, and Nexperia accepts no liability for any assistance with applications or customer product design. It is customer's sole responsibility to determine whether the Nexperia product is suitable and fit for the customer's applications and products planned, as well as for the planned application and use of customer's third party customer(s). Customers should provide appropriate design and operating safeguards to minimize the risks associated with their applications and products.

Nexperia does not accept any liability related to any default, damage, costs or problem which is based on any weakness or default in the customer's applications or products, or the application or use by customer's third party customer(s). Customer is responsible for doing all necessary testing for the customer's applications and products using Nexperia products in order to avoid a default of the applications and the products or of the application or use by customer's third party customer(s). Nexperia does not accept any liability in this respect.

**Limiting values** — Stress above one or more limiting values (as defined in the Absolute Maximum Ratings System of IEC 60134) will cause permanent damage to the device. Limiting values are stress ratings only and (proper) operation of the device at these or any other conditions above those given in the Recommended operating conditions section (if present) or the Characteristics sections of this document is not warranted. Constant or repeated exposure to limiting values will permanently and irreversibly affect the quality and reliability of the device.

**Terms and conditions of commercial sale** — Nexperia products are sold subject to the general terms and conditions of commercial sale, as published at <http://www.nexperia.com/profile/terms>, unless otherwise agreed in a valid written individual agreement. In case an individual agreement is concluded only the terms and conditions of the respective agreement shall apply. Nexperia hereby expressly objects to applying the customer's general terms and conditions with regard to the purchase of Nexperia products by customer.

**No offer to sell or license** — Nothing in this document may be interpreted or construed as an offer to sell products that is open for acceptance or the grant, conveyance or implication of any license under any copyrights, patents or other industrial or intellectual property rights.

**Export control** — This document as well as the item(s) described herein may be subject to export control regulations. Export might require a prior authorization from competent authorities.

**Non-automotive qualified products** — Unless this data sheet expressly states that this specific Nexperia product is automotive qualified, the product is not suitable for automotive use. It is neither qualified nor tested in accordance with automotive testing or application requirements. Nexperia accepts no liability for inclusion and/or use of non-automotive qualified products in automotive equipment or applications.

In the event that customer uses the product for design-in and use in automotive applications to automotive specifications and standards, customer (a) shall use the product without Nexperia's warranty of the product for such automotive applications, use and specifications, and (b) whenever customer uses the product for automotive applications beyond

Nexperia's specifications such use shall be solely at customer's own risk, and (c) customer fully indemnifies Nexperia for any liability, damages or failed product claims resulting from customer design and use of the product for automotive applications beyond Nexperia's standard warranty and Nexperia's product specifications.

**Translations** — A non-English (translated) version of a document is for reference only. The English version shall prevail in case of any discrepancy between the translated and English versions.

## 16.4 Trademarks

Notice: All referenced brands, product names, service names and trademarks are the property of their respective owners.

## 17. Contact information

For more information, please visit: <http://www.nexperia.com>

For sales office addresses, please send an email to: [salesaddresses@nexperia.com](mailto:salesaddresses@nexperia.com)

## 18. Contents

<b>1</b>	<b>General description</b> . . . . .	<b>1</b>	12.1.3	Sequence 3 (FIFOA runs full) . . . . .	29
<b>2</b>	<b>Features and benefits</b> . . . . .	<b>1</b>	12.1.4	Sequence 4 (both FIFOs full, starting SHIFT-OUT). . . . .	29
<b>3</b>	<b>Ordering information</b> . . . . .	<b>2</b>	12.1.5	Sequence 5 (FIFOA runs empty) . . . . .	29
<b>4</b>	<b>Functional diagram</b> . . . . .	<b>2</b>	12.1.6	Sequence 6 (FIFOB runs empty) . . . . .	29
<b>5</b>	<b>Pinning information</b> . . . . .	<b>4</b>	<b>13</b>	<b>Package outline</b> . . . . .	<b>30</b>
5.1	Pinning . . . . .	4	<b>14</b>	<b>Abbreviations</b> . . . . .	<b>33</b>
5.2	Pin description . . . . .	4	<b>15</b>	<b>Revision history</b> . . . . .	<b>33</b>
<b>6</b>	<b>Functional description</b> . . . . .	<b>5</b>	<b>16</b>	<b>Legal information</b> . . . . .	<b>34</b>
6.1	Inputs and outputs . . . . .	5	16.1	Data sheet status . . . . .	34
6.1.1	Data inputs (D0 to D3) . . . . .	5	16.2	Definitions . . . . .	34
6.1.2	Data outputs (Q0 to Q3) . . . . .	5	16.3	Disclaimers . . . . .	34
6.1.3	Master-reset (MR) . . . . .	5	16.4	Trademarks . . . . .	35
6.1.4	Status flag outputs (DIR, DOR) . . . . .	5	<b>17</b>	<b>Contact information</b> . . . . .	<b>35</b>
6.1.5	Shift-in control (SI) . . . . .	5	<b>18</b>	<b>Contents</b> . . . . .	<b>36</b>
6.1.6	Shift-out control (SO) . . . . .	5			
6.1.7	Output enable (OE) . . . . .	5			
6.2	Data input . . . . .	6			
6.3	Data transfer . . . . .	6			
6.4	Data output . . . . .	6			
6.5	High-speed burst mode . . . . .	6			
6.6	Expanded format . . . . .	7			
<b>7</b>	<b>Limiting values</b> . . . . .	<b>7</b>			
<b>8</b>	<b>Recommended operating conditions</b> . . . . .	<b>8</b>			
<b>9</b>	<b>Static characteristics</b> . . . . .	<b>8</b>			
<b>10</b>	<b>Dynamic characteristics</b> . . . . .	<b>10</b>			
<b>11</b>	<b>Waveforms</b> . . . . .	<b>15</b>			
11.1	Master reset applied with FIFO full . . . . .	15			
11.2	Shifting in sequence FIFO empty to FIFO full . . . . .	16			
11.3	With FIFO full; SI held HIGH in anticipation of empty location . . . . .	17			
11.4	SO input to Qn outputs propagation delay . . . . .	17			
11.5	Shifting out sequence; FIFO full to FIFO empty . . . . .	18			
11.6	Shift-in operation; high-speed burst mode . . . . .	18			
11.7	Shift-out operation; high-speed burst mode . . . . .	19			
11.8	With FIFO empty; SO is held HIGH in anticipation . . . . .	20			
11.9	MR to SI recovery time . . . . .	21			
11.10	Enable and disable times . . . . .	21			
11.11	Set-up and hold times . . . . .	22			
11.12	Test circuit for measuring switching times . . . . .	22			
<b>12</b>	<b>Application information</b> . . . . .	<b>23</b>			
12.1	Expanded format . . . . .	24			
12.1.1	Sequence 1 (both FIFOs empty, starting SHIFT-IN process) . . . . .	28			