



# Mag Layers USA, INC

## Specification Sheet

P/N : **GMLB-160808- Series-A-N8-RU**

### Products:

[Molded Power Chokes](#)

[Multilayer Chip Inductors](#)

[Lan Transformer](#)

[RF Passive / Antennas](#)

[Automotive](#)

### Certifications:

[ISO9001](#)

[IATF16949](#)

[ISO14001](#)

[QC080000](#)

### US Office

5406 Bolsa Ave.,  
Huntington Beach, CA 92649  
(714) 898-8377

### Contact Us

[www.maglayersusa.com](http://www.maglayersusa.com)  
[info@maglayersusa.com](mailto:info@maglayersusa.com)



## PRODUCT DIMENSION

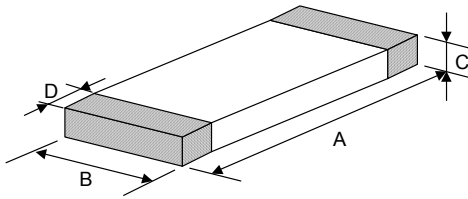

NOTE : Dimensions in mm

| PRODUCT NO.           | A                         | B                         | C                         | D                         |
|-----------------------|---------------------------|---------------------------|---------------------------|---------------------------|
| GMLB-160808<br>(0603) | 1.6±0.15<br>(0.063±0.006) | 0.8±0.15<br>(0.031±0.006) | 0.8±0.15<br>(0.031±0.006) | 0.3±0.20<br>(0.012±0.008) |

## CURRENT DERATING

In operating temperatures exceeding +85°C, derating of current is necessary for chip ferrite beads for which rated current is 1.5A or over. Please apply the derating curve shown below according to the operating temperature.

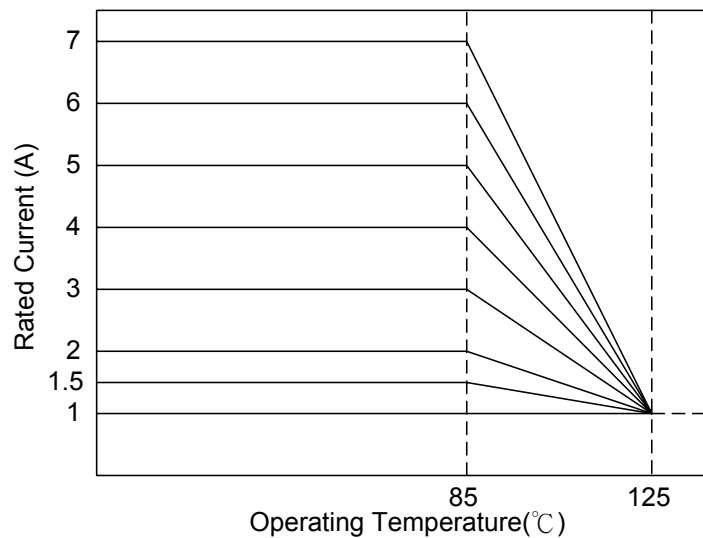

## ELECTRICAL REQUIREMENTS

| Part Number             | Impedance ( $\Omega$ )<br>at 100 MHz | R <sub>DC</sub> ( $\Omega$ )<br>Max. | I <sub>DC</sub> (mA)<br>Max. | Operating<br>Temp. Range ( $^{\circ}\text{C}$ ) |
|-------------------------|--------------------------------------|--------------------------------------|------------------------------|---|
| GMLB-160808-0030A-N8-RU | 30 $\pm$ 25%                         | 0.20                                 | 400                          | -55 ~ +125                                      |
| GMLB-160808-0040A-N8-RU | 40 $\pm$ 25%                         |                                      | 300                          |   |
| GMLB-160808-0060A-N8-RU | 60 $\pm$ 25%                         | 0.40                                 |                              |   |
| GMLB-160808-0080A-N8-RU | 80 $\pm$ 25%                         |                                      |                              |   |
| GMLB-160808-0100A-N8-RU | 100 $\pm$ 25%                        |                                      |                              |   |
| GMLB-160808-0120A-N8-RU | 120 $\pm$ 25%                        | 0.50                                 | 200                          |   |
| GMLB-160808-0180A-N8-RU | 180 $\pm$ 25%                        |                                      |                              |   |
| GMLB-160808-0220A-N8-RU | 220 $\pm$ 25%                        |                                      |                              |   |
| GMLB-160808-0240A-N8-RU | 240 $\pm$ 25%                        |                                      |                              |   |
| GMLB-160808-0300A-N8-RU | 300 $\pm$ 25%                        | 0.70                                 | 150                          |   |
| GMLB-160808-0450A-N8-RU | 450 $\pm$ 25%                        |                                      |                              |   |
| GMLB-160808-0600A-N8-RU | 600 $\pm$ 25%                        | 1.00                                 | 100                          |   |
| GMLB-160808-1000A-N8-RU | 1000 $\pm$ 25%                       |                                      |                              |   |
| GMLB-160808-1200A-N8-RU | 1200 $\pm$ 25%                       |                                      |                              |   |
| GMLB-160808-1500A-N8-RU | 1500 $\pm$ 25%                       |                                      | 200                          |   |

- Temperature rise should be less than 40 $^{\circ}\text{C}$  for P-type and less than 25 $^{\circ}\text{C}$  for other types when rated current is applied.

## MEASURING METHOD / CONDITION

- Test Instrument:

Z: Agilent 4291B Impedance Analyzer, Test Fixture: Agilent 16192

Osc. Level: 500mV

R<sub>DC</sub>: Agilent 34401A

- Test Condition:

< Unless otherwise specified >

Temperature: 15 $^{\circ}\text{C}$  to 35 $^{\circ}\text{C}$  Humidity: 25% to 85% RH

< In case of doubt >

Temperature: 25 $^{\circ}\text{C} \pm 2^{\circ}\text{C}$  Humidity: 60% to 70% RH



# TYPICAL ELECTRICAL CHARACTERISTICS (T=25°C)

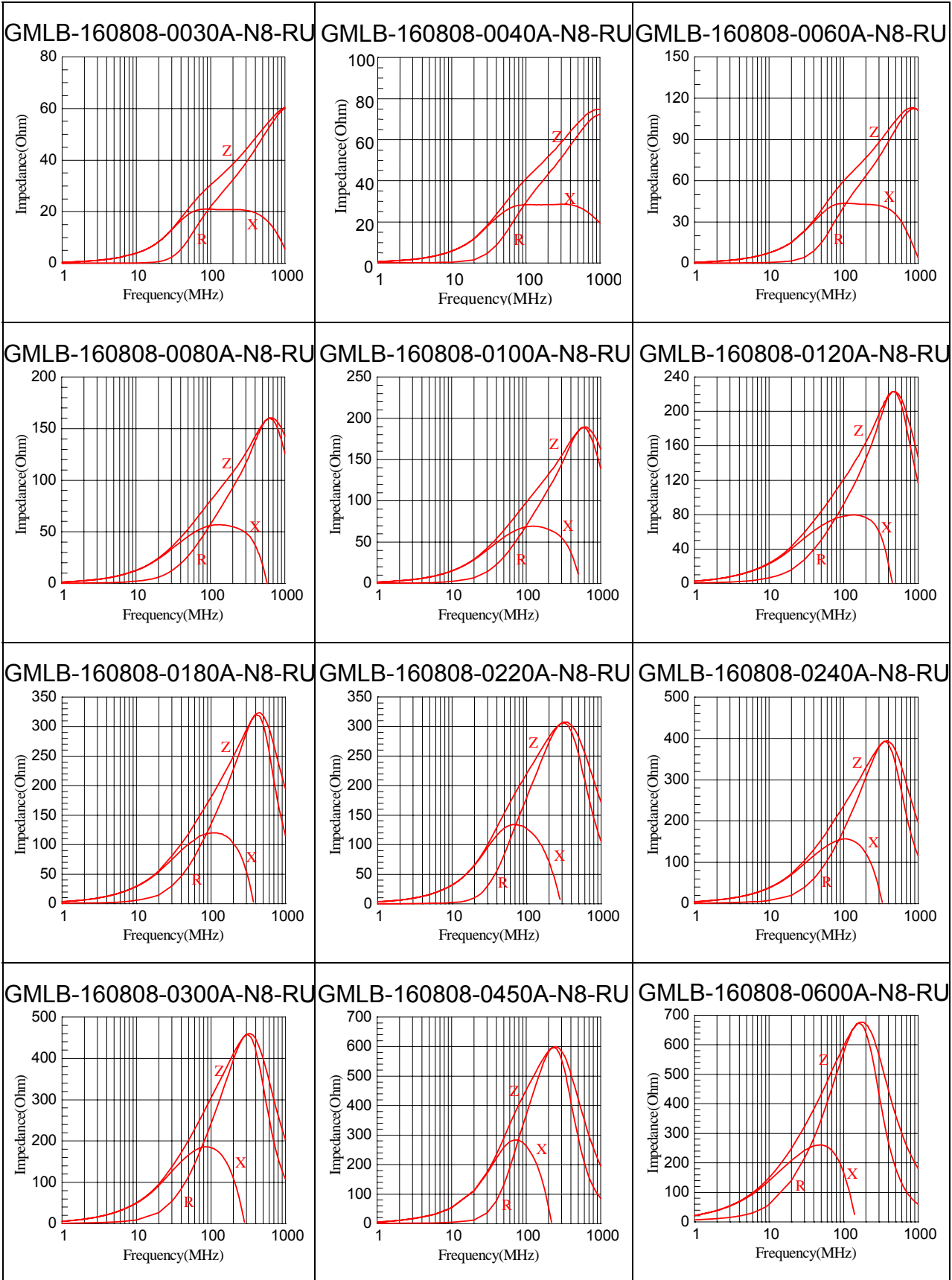

GMLB-160808-1000A-N8-RU

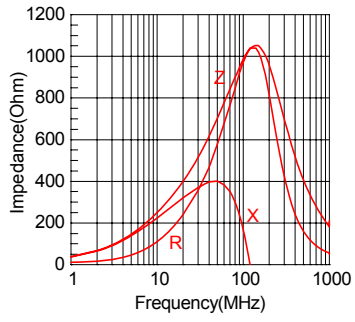

GMLB-160808-1200A-N8-RU

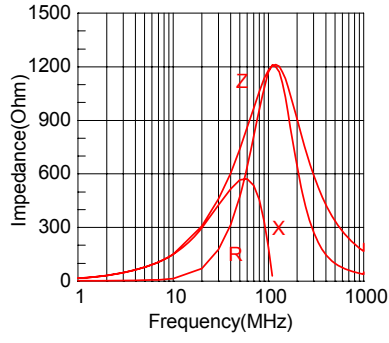

GMLB-160808-1500A-N8-RU

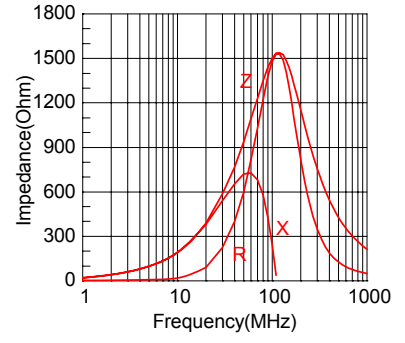

## PACKAGING

### ● Peel-off Force

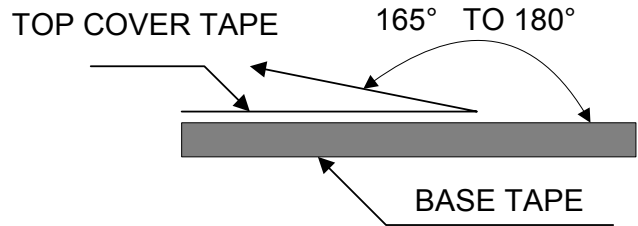
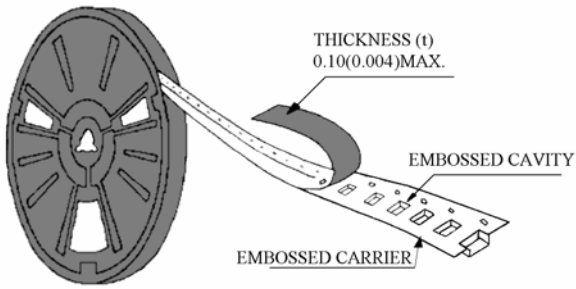

The force for peeling off cover tape is 10 grams in the arrow direction.

### ● Dimension (Unit: mm)

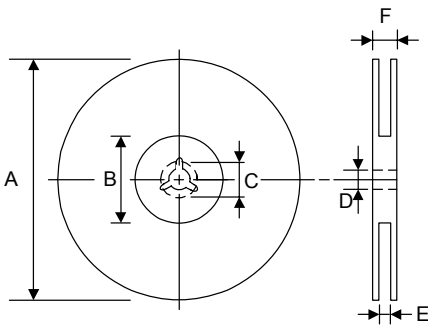

| TYPE  | A       | B             | C         | D         | E         | F       |
|-------|---------|---------------|-----------|-----------|-----------|---------|
| 8 mm  | 178±1   | 60 +0.5<br>-0 | -         | 13 ±0.2   | 9 ±0.5    | 12 ±0.5 |
| 12 mm | 178±0.3 | 60 ±0.2       | 19.3 ±0.1 | 13.5 ±0.1 | 13.6 ±0.1 | -       |

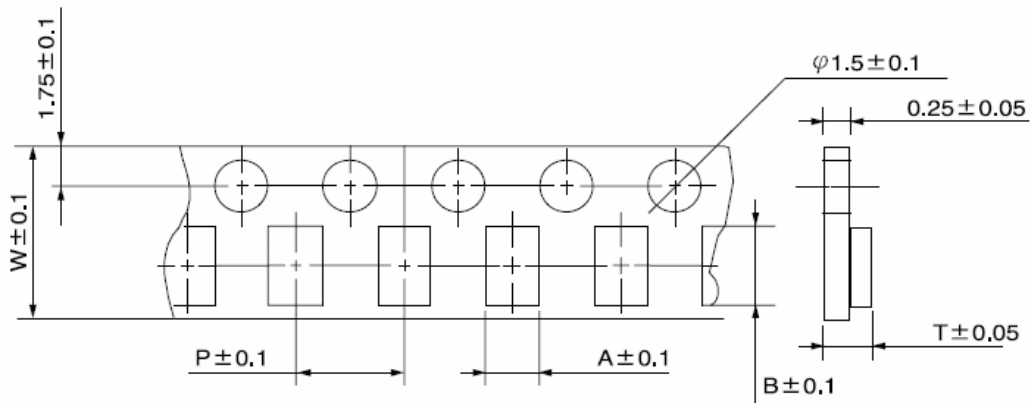

| TYPE | SIZE   | A   | B   | W | P | T               | CHIPS/REEL |
|------|--------|-----|-----|---|---|-----------------|------------|
| GMLB | 160808 | 1.1 | 1.9 | 8 | 4 | 1.1, *0.95±0.05 | 4000       |

\*: For paper reels

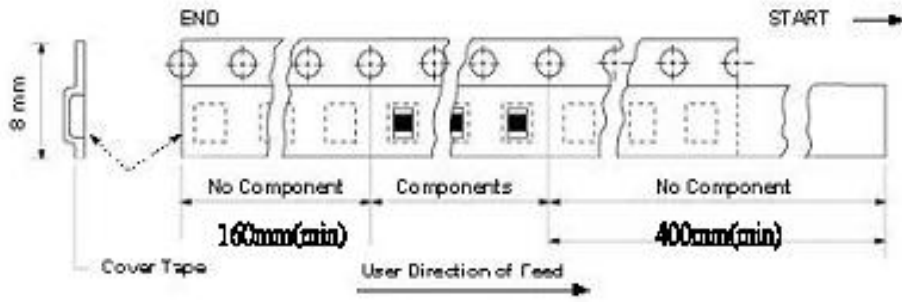

- Taping Quantity

|               |             |
|---------------|-------------|
| <b>SERIES</b> | <b>1608</b> |
| PCS/Reel      | 4000        |

- Tape Packing Case

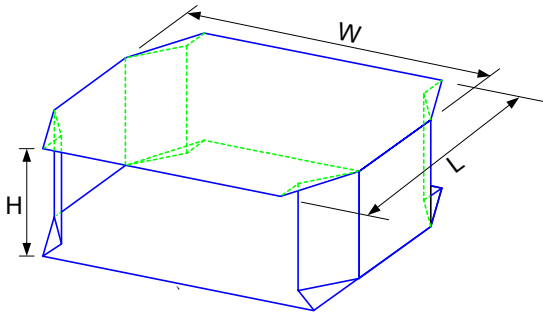

| No. of Reels | W      | L      | H       |
|--------------|--------|--------|---------|
| 2            | 18±0.5 | 18±0.5 | 2.4±0.2 |
| 3            | 18±0.5 | 18±0.5 | 3.6±0.2 |
| 4            | 18±0.5 | 18±0.5 | 4.8±0.2 |
| 5            | 18±0.5 | 18±0.5 | 6.0±0.2 |

Unit: cm

## RECOMMENDED PCB LAYOUT

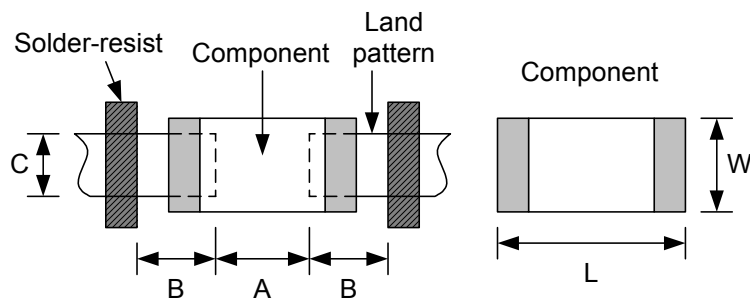

Unit: mm

| Type | 1608    |     |
|------|---------|-----|
| Size | L       | 1.6 |
|      | W       | 0.8 |
| A    | 0.6~0.8 |     |
| B    | 0.6~0.8 |     |
| C    | 0.6~0.8 |     |



## RELIABILITY TEST

| ●Mechanical Performance Test |  |   |        |            |
|------------------------------|--|---|--------|------------|
| ITEM                         | SPECIFICATION  | TEST CONDITION  |        |            |
| Solderability                | More than 90% of the terminal electrode shall be covered with fresh solder.                        | Solder:<br>Sn-3.0Ag-0.5Cu<br>Solder Temperature:<br>245 ± 5°C<br>Flux: Rosin<br>Dip Time: 3 ± 1 Seconds |        |            |
| Soldering Heat Resistance    | The chip shall not crack.<br>More than 75% of the terminal electrode shall be covered with solder. | Solder temperature : 260 ± 5°C<br>Flux: Rosin<br>Dip time: 10 ± 1 seconds                               |        |            |
| Terminal Strength            | The terminal electrode shall not be broken off nor the ferrite damaged.                            | TYPE  | W(KGF) | TIME (SEC) |
|                              |  | GMLB-160808   | 0.6    | 30 ± 5     |
| Bending Strength             | No mechanical damage.<br>The ferrite shall not be damaged.   | TYPE  | A(MM)  | P(KGF)     |
|                              |  | GMLB-160808   | 1.0    | 1.0        |

  

| ● Climatic test                      |   |   |  |  |
|--------------------------------------|---|---|--|--|
| ITEM                                 | SPECIFICATION   | TEST CONDITION  |  |  |
| Thermal Shock<br>(Temperature Cycle) | Impedance shall be within ± 20% of the initial value. | Temperature: -55°C~125°C for 30 minutes each, 100 cycles.       |  |  |
| Humidity Resistance                  |   | Temperature : 60°C<br>Humidity: 95% RH<br>Time: 1000 ± 12 Hours |  |  |
| High Temperature Resistance          |   | Temperature : 85°C±2°C<br>Time: 1000 ± 12 Hours                 |  |  |

|  |
|--|
| 1. Operating Temperature Range: -55 °C TO +125°C   |
| 2. Storage Condition: The temperature should be within -40°C~85°C and humidity should be less than 75% RH. The product should be used within 6 months from the time of delivery. |

## RECOMMENDED REFLOW SOLDERING PROFILE

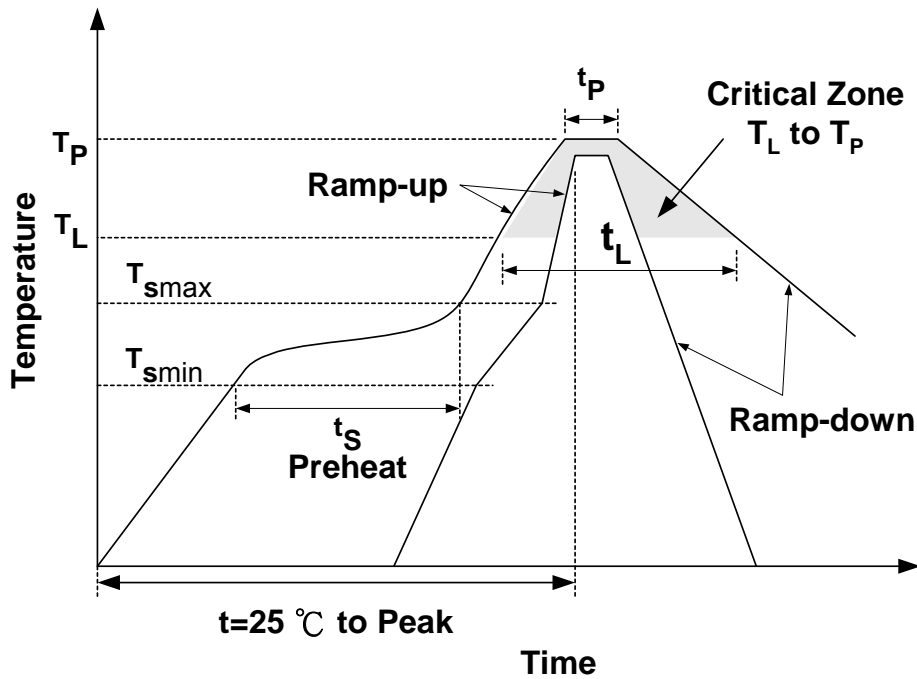

| Profile Feature                                      |                       | Sn-Pb           | Pb-Free         |
|--|-----------------------|-----------------|-----------------|
| Preheat  | $t_s$                 | 60~120 seconds  | 60~180 seconds  |
|  | $T_{smin}$            | 100°C           | 150°C           |
|  | $T_{smax}$            | 150°C           | 200°C           |
| Average ramp-up rate ( $T_{smax}$ to $T_P$ )         |                       | 3°C/second max. | 3°C/second max. |
| Time main above                                      | Temperature ( $T_L$ ) | 183°C           | 217°C           |
|  | Time ( $t_L$ )        | 60~150 seconds  | 60~150 seconds  |
| Peak temperature ( $T_P$ )                           |                       | 230°C           | 250~260°C       |
| Time within 5°C of actual peak temperature ( $t_p$ ) |                       | 10 seconds      | 10 seconds      |
| Ramp-down rate                                       |                       | 6°C/sec max.    | 6°C/sec max.    |
| Time 25°C to peak temperature                        |                       | 6 minutes max.  | 8 minutes max.  |

## NOTES

The contents of this data sheet are subject to change without notice. Please confirm the specifications and delivery conditions when placing your order.