

DSP56362

24-Bit Audio Digital Signal Processor

1 Overview

Freescale Semiconductor, Inc. designed the DSP56362 to support digital audio applications requiring digital audio compression and decompression, sound field processing, acoustic equalization, and other digital audio algorithms. The DSP56362 uses the high performance, single-clock-per-cycle DSP56300 core family of programmable CMOS digital signal processors (DSPs) combined with the audio signal processing capability of the Freescale Symphony™ DSP family, as shown in [Figure 1-1](#). This design provides a two-fold performance increase over Freescale's popular Symphony family of DSPs while retaining code compatibility. Significant architectural enhancements include a barrel shifter, 24-bit addressing, instruction cache, and direct memory access (DMA). The DSP56362 offers 100 million instructions per second (MIPS) using an internal 100 MHz clock at 3.3 V.

Contents

| | |
|---------------------------------------------------|------------|
| 1 Overview | 1-1 |
| 2 Signal/Connection Descriptions | 2-1 |
| 3 Specifications | 3-1 |
| 4 Packaging | 4-1 |
| 5 Design Considerations | 5-1 |
| 6 Ordering Information | 6-1 |
| A Power Consumption Benchmark | A-1 |
| B IBIS Model | B-1 |

This document contains information on a new product. Specifications and information herein are subject to change without notice.

© Freescale Semiconductor, Inc., 2006. All rights reserved.

Data Sheet Conventions

This data sheet uses the following conventions:

- OVERBAR** Used to indicate a signal that is active when pulled low (For example, the $\overline{\text{RESET}}$ pin is active when low.)
- “asserted” Means that a high true (active high) signal is high or that a low true (active low) signal is low
- “deasserted” Means that a high true (active high) signal is low or that a low true (active low) signal is high

| Examples: | Signal/Symbol | Logic State | Signal State | Voltage* |
|-----------|-------------------------|-------------|--------------|-------------------|
| | $\overline{\text{PIN}}$ | True | Asserted | V_{IL} / V_{OL} |
| | $\overline{\text{PIN}}$ | False | Deasserted | V_{IH} / V_{OH} |
| | PIN | True | Asserted | V_{IH} / V_{OH} |
| | PIN | False | Deasserted | V_{IL} / V_{OL} |

Note: *Values for V_{IL} , V_{OL} , V_{IH} , and V_{OH} are defined by individual product specifications.

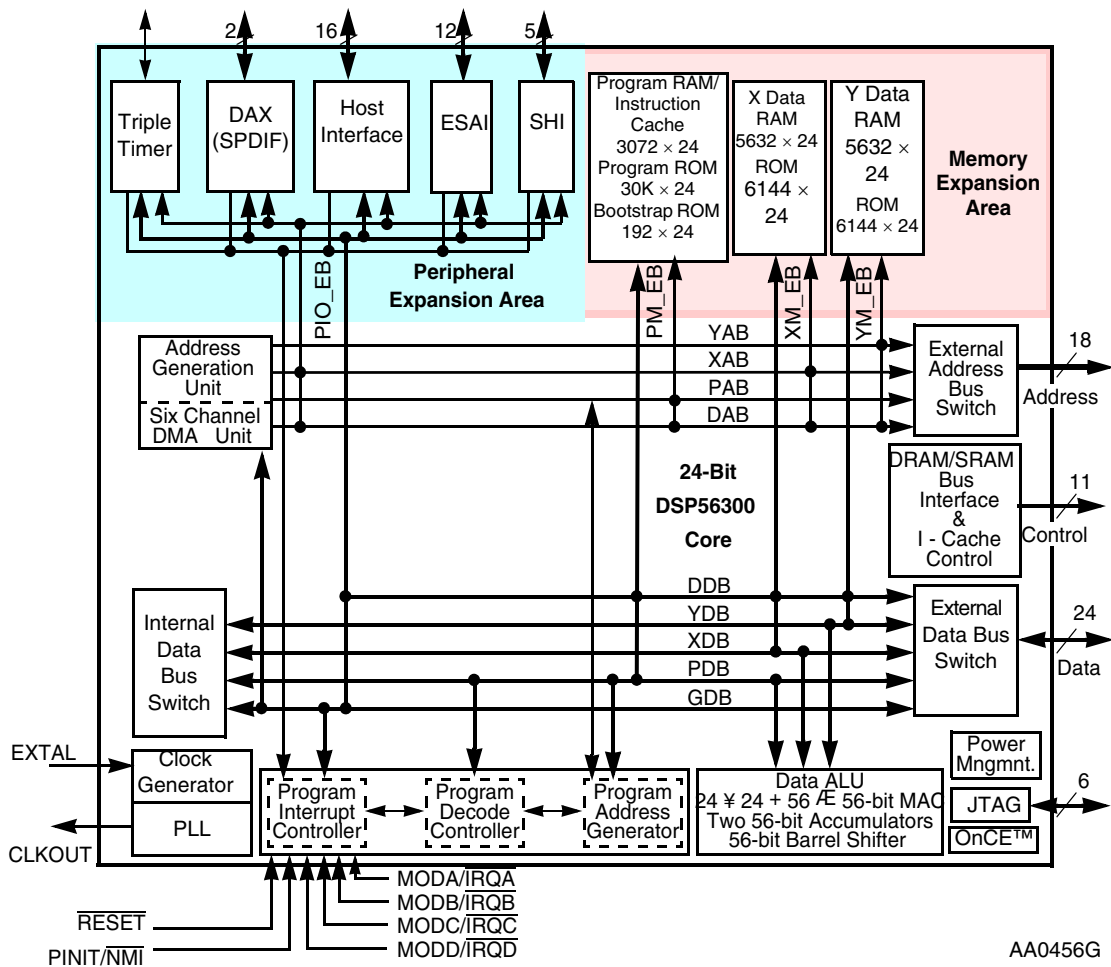

Figure 1-1 DSP56362 Block Diagram

1.1 Features

- Multimode, multichannel decoder software functionality
 - Dolby Digital and Pro Logic
 - MPEG2 5.1
 - DTS
 - Bass management
- Digital audio post-processing capabilities
 - 3D Virtual surround sound
 - Lucasfilm THX5.1
 - Soundfield processing
 - Equalization
- Digital Signal Processing Core
 - 100 MIPS with a 100 MHz clock at 3.3 V +/- 5%
 - Object code compatible with the DSP56000 core
 - Highly parallel instruction set
 - Data arithmetic logic unit (ALU)
 - Fully pipelined 24 x 24-bit parallel multiplier-accumulator (MAC)
 - 56-bit parallel barrel shifter (fast shift and normalization; bit stream generation and parsing)
 - Conditional ALU instructions
 - 24-bit or 16-bit arithmetic support under software control
 - Program control unit (PCU)
 - Position independent code (PIC) support
 - Addressing modes optimized for DSP applications (including immediate offsets)
 - On-chip instruction cache controller
 - On-chip memory-expandable hardware stack
 - Nested hardware DO loops
 - Fast auto-return interrupts
 - Direct memory access (DMA)
 - Six DMA channels supporting internal and external accesses
 - One-, two-, and three- dimensional transfers (including circular buffering)
 - End-of-block-transfer interrupts
 - Triggering from interrupt lines and all peripherals
 - Phase-locked loop (PLL)
 - Software programmable PLL-based frequency synthesizer for the core clock
 - Allows change of low-power divide factor (DF) without loss of lock
 - Output clock with skew elimination
 - Hardware debugging support

- On-Chip Emulation (OnCE¹) module
- Joint Action Test Group (JTAG) test access port (TAP)
- Address trace mode reflects internal program RAM accesses at the external port
- On-Chip Memories
 - Modified Harvard architecture allows simultaneous access to program and data memories
 - 30720 x 24-bit on-chip program ROM¹ (disabled in 16-bit compatibility mode)
 - 6144 x 24-bit on-chip X-data ROM¹
 - 6144 x 24-bit on-chip Y-data ROM¹
 - Program RAM, instruction cache, X data RAM, and Y data RAM sizes are programmable

| Instruction Cache | Switch Mode | Program RAM Size | Instruction Cache Size | X Data RAM Size | Y Data RAM Size |
|-------------------|-------------|------------------|------------------------|-----------------|-----------------|
| Disabled | Disabled | 3072 x 24-bit | 0 | 5632 x 24-bit | 5632 x 24-bit |
| Enabled | Disabled | 2048 x 24-bit | 1024 x 24-bit | 5632 x 24-bit | 5632 x 24-bit |
| Disabled | Enabled | 5120 x 24-bit | 0 | 5632 x 24-bit | 3584 x 24-bit |
| Enabled | Enabled | 4096 x 24-bit | 1024 x 24-bit | 5632 x 24-bit | 3584 x 24-bit |

- 192 x 24-bit bootstrap ROM (disabled in sixteen-bit compatibility mode)
- Off-Chip Memory Expansion
 - Data memory expansion to 256K x 24-bit word memory for P, X, and Y memory using SRAM.
 - Data memory expansion to 16M x 24-bit word memory for P, X, and Y memory using DRAM.
 - External memory expansion port(twenty-four data pins for high speed external memory access allowing for a large number of external accesses per sample)
 - Chip select logic for glueless interface to SRAMs
 - On-chip DRAM controller for glueless interface to DRAMs
- Peripheral and Support Circuits
 - Enhanced serial audio interface (ESAI) includes:
 - Six serial data lines, 4 selectable as receive or transmit and 2 transmit only.
 - Master or slave capability
 - I²S, Sony, AC97, and other audio protocol implementations
 - Serial host interface (SHI) features:
 - SPI protocol with multi-master capability
 - I²C protocol with single-master capability
 - Ten-word receive FIFO
 - Support for 8-, 16-, and 24-bit words.
 - Byte-wide parallel host interface (HDI08) with DMA support
 - DAX features one serial transmitter capable of supporting S/PDIF, IEC958, IEC1937, CP-340, and AES/EBU digital audio formats; alternate configuration supports up to two GPIO lines

1. These ROMs may be factory programmed with data or programs provided by the application developer.

- Triple timer module with single external interface or GPIO line
- On-chip peripheral registers are memory mapped in data memory space
- Reduced Power Dissipation
 - Very low-power (3.3 V) CMOS design
 - Wait and stop low-power standby modes
 - Fully-static logic, operation frequency down to 0 Hz (dc)
 - Optimized power management circuitry (instruction-dependent, peripheral-dependent, and mode-dependent)

1.2 Package

- 144-pin plastic thin quad flat pack (LQFP) surface-mount package

1.3 Documentation

Table 1-1 lists the documents that provide a complete description of the DSP56362 and are required to design properly with the part. Documentation is available from a local Freescale distributor, a Freescale semiconductor sales office, a Freescale Literature Distribution Center, or through the Freescale DSP home page on the Internet (the source for the latest information).

Table 1-1 DSP56362 Documentation

| Document Name | Description | Order Number |
|----------------------------------------|---------------------------------------------------------------------------------------------------------|--------------|
| DSP56300 Family Manual | Detailed description of the 56000-family architecture and the 24-bit core processor and instruction set | DSP56300FM |
| DSP56362 User's Manual | Detailed description of memory, peripherals, and interfaces | DSP56362UM |
| DSP56362 Product Brief | Brief description of the chip | DSP56362P |
| DSP56362 Data Sheet (this document) | Electrical and timing specifications; pin and package descriptions | DSP56362 |

NOTES

2 Signal/Connection Descriptions

2.1 Signal Groupings

The input and output signals of the DSP56362 are organized into functional groups, which are listed in [Table 2-1](#) and illustrated in [Figure 2-1](#).

The DSP56362 is operated from a 3.3 V supply; however, some of the inputs can tolerate 5 V. A special notice for this feature is added to the signal descriptions of those inputs.

Table 2-1 DSP56362 Functional Signal Groupings

| Functional Group | | Number of Signals | Detailed Description |
|---------------------------------|---------------------|-------------------|----------------------------|
| Power (V _{CC}) | | 20 | Table 2-2 |
| Ground (GND) | | 19 | Table 2-3 |
| Clock and PLL | | 4 | Table 2-4 |
| Address bus | Port A ¹ | 18 | Table 2-5 |
| Data bus | | 24 | Table 2-6 |
| Bus control | | 11 | Table 2-7 |
| Interrupt and mode control | | 5 | Table 2-8 |
| HDI08 | Port B ² | 16 | Table 2-9 |
| SHI | | 5 | Table 2-10 |
| ESAI | Port C ³ | 12 | Table 2-11 |
| Digital audio transmitter (DAX) | Port D ⁴ | 2 | Table 2-12 |
| Timer | | 1 | Table 2-13 |
| JTAG/OnCE Port | | 6 | Table 2-14 |

¹ Port A is the external memory interface port, including the external address bus, data bus, and control signals.

² Port B signals are the GPIO port signals which are multiplexed with the HDI08 signals.

³ Port C signals are the GPIO port signals which are multiplexed with the ESAI signals.

⁴ Port D signals are the GPIO port signals which are multiplexed with the DAX signals.

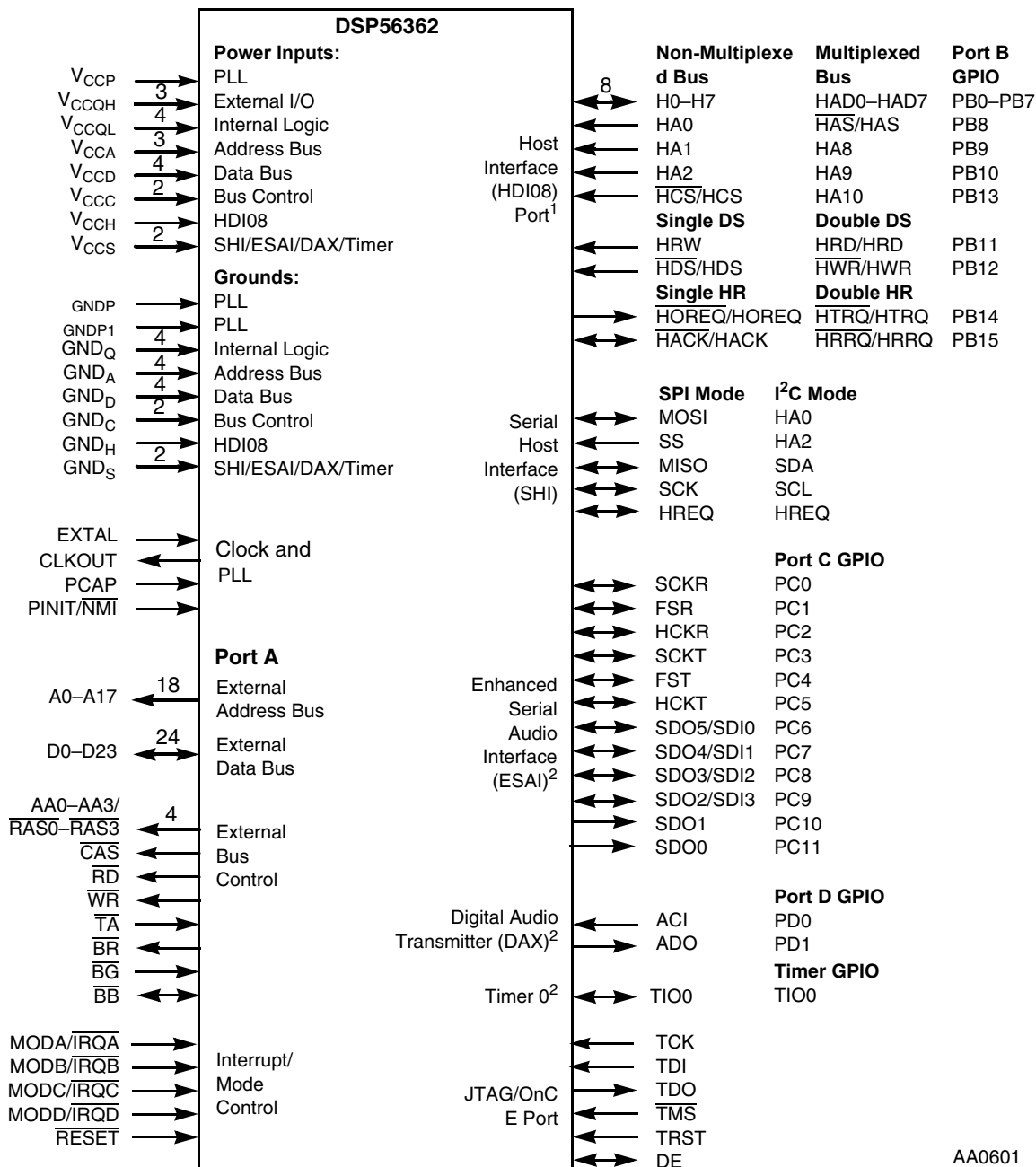

- Notes:
1. The HDI08 port supports a nonmultiplexed or a multiplexed bus, single or double data strobe (DS), and single or double host request (HR) configurations. Since each of these modes is configured independently, any combination of these modes is possible. These HDI08 signals can also be configured alternately as GPIO signals (PB0–PB15). Signals with dual designations (e.g., \overline{HAS}/HAS) have configurable polarity.
 2. The ESAI signals are multiplexed with the port C GPIO signals (PC0–PC11). The DAX signals are multiplexed with the Port D GPIO signals (PD0–PD1). The timer 0 signal can be configured alternately as the timer GPIO signal (TIO0).

Figure 2-1 Signals Identified by Functional Group

2.2 Power

Table 2-2 Power Inputs

| Power Name | Description |
|----------------|------------------------------------------------------------------------------------------------------------------------------------------------------------------------------------------------------------------------------------------------------------------------------------------|
| V_{CCP} | PLL Power — V_{CCP} is V_{CC} dedicated for PLL use. The voltage should be well-regulated and the input should be provided with an extremely low impedance path to the V_{CC} power rail. There is one V_{CCP} input. |
| V_{CCQL} (4) | Quiet Core (Low) Power — V_{CCQL} is an isolated power for the core processing logic. This input must be tied externally to all other chip power inputs. The user must provide adequate external decoupling capacitors. There are four V_{CCQ} inputs. |
| V_{CCQH} (3) | Quiet External (High) Power — V_{CCQH} is a quiet power source for I/O lines. This input must be tied externally to all other chip power inputs. The user must provide adequate decoupling capacitors. There are three V_{CCQH} inputs. |
| V_{CCA} (3) | Address Bus Power — V_{CCA} is an isolated power for sections of the address bus I/O drivers. This input must be tied externally to all other chip power inputs. The user must provide adequate external decoupling capacitors. There are three V_{CCA} inputs. |
| V_{CCD} (4) | Data Bus Power — V_{CCD} is an isolated power for sections of the data bus I/O drivers. This input must be tied externally to all other chip power inputs. The user must provide adequate external decoupling capacitors. There are four V_{CCD} inputs. |
| V_{CCC} (2) | Bus Control Power — V_{CCC} is an isolated power for the bus control I/O drivers. This input must be tied externally to all other chip power inputs. The user must provide adequate external decoupling capacitors. There are two V_{CCC} inputs. |
| V_{CCH} | Host Power — V_{CCH} is an isolated power for the HDI08 I/O drivers. This input must be tied externally to all other chip power inputs. The user must provide adequate external decoupling capacitors. There is one V_{CCH} input. |
| V_{CCS} (2) | SHI, ESAI, DAX, and Timer Power — V_{CCS} is an isolated power for the SHI, ESAI, DAX, and Timer I/O drivers. This input must be tied externally to all other chip power inputs. The user must provide adequate external decoupling capacitors. There are two V_{CCS} inputs. |

2.3 Ground

Table 2-3 Grounds

| Ground Name | Description |
|----------------------|-------------------------------------------------------------------------------------------------------------------------------------------------------------------------------------------------------------------------------------------------------------------------------------------------------------------------------------|
| GND _P | PLL Ground —GND _P is a ground dedicated for PLL use. The connection should be provided with an extremely low-impedance path to ground. V _{CCP} should be bypassed to GND _P by a 0.47 μF capacitor located as close as possible to the chip package. There is one GND _P connection. |
| GND _{P1} | PLL Ground 1 —GND _{P1} is a ground dedicated for PLL use. The connection should be provided with an extremely low-impedance path to ground. There is one GND _{P1} connection. |
| GND _Q (4) | Quiet Ground —GND _Q is an isolated ground for the internal processing logic. This connection must be tied externally to all other chip ground connections. The user must provide adequate external decoupling capacitors. There are four GND _Q connections. |
| GND _A (4) | Address Bus Ground —GND _A is an isolated ground for sections of the address bus I/O drivers. This connection must be tied externally to all other chip ground connections. The user must provide adequate external decoupling capacitors. There are four GND _A connections. |
| GND _D (4) | Data Bus Ground —GND _D is an isolated ground for sections of the data bus I/O drivers. This connection must be tied externally to all other chip ground connections. The user must provide adequate external decoupling capacitors. There are four GND _D connections. |
| GND _C (2) | Bus Control Ground —GND _C is an isolated ground for the bus control I/O drivers. This connection must be tied externally to all other chip ground connections. The user must provide adequate external decoupling capacitors. There are two GND _C connections. |
| GND _H | Host Ground —GND _H is an isolated ground for the HDI08 I/O drivers. This connection must be tied externally to all other chip ground connections. The user must provide adequate external decoupling capacitors. There is one GND _H connection. |
| GND _S (2) | SHI, ESAI, DAX, and Timer Ground —GND _S is an isolated ground for the SHI, ESAI, DAX, and Timer I/O drivers. This connection must be tied externally to all other chip ground connections. The user must provide adequate external decoupling capacitors. There are two GND _S connections. |

2.4 Clock and PLL

Table 2-4 Clock and PLL Signals

| Signal Name | Type | State during Reset | Signal Description |
|-------------|--------|--------------------|-----------------------------------------------------------------------------------------------------------------------------------------------------------------------------------------------------------------------------------------------------------------------------------------------------------------------------------------------------------------------------------|
| EXTAL | Input | Input | External Clock Input —An external clock source must be connected to EXTAL in order to supply the clock to the internal clock generator and PLL. <i>This input cannot tolerate 5V.</i> |
| CLKOUT | Output | Chip-Driven | Clock Output —CLKOUT provides an output clock synchronized to the internal core clock phase. If the PLL is enabled and both the multiplication and division factors equal one, then CLKOUT is also synchronized to EXTAL. If the PLL is disabled, the CLKOUT frequency is half the frequency of EXTAL. CLKOUT is not functional at frequencies of 100 MHz and above. |

Table 2-4 Clock and PLL Signals (continued)

| Signal Name | Type | State during Reset | Signal Description |
|-------------------------|-------|--------------------|-----------------------------------------------------------------------------------------------------------------------------------------------------------------------------------------------------------------------------------------------------------------------------------------------------------------------------------------------------------------------------------------------------------------------------------------------------------------------------------------------------------------------------------------------------------|
| PCAP | Input | Input | PLL Capacitor —PCAP is an input connecting an off-chip capacitor to the PLL filter. Connect one capacitor terminal to PCAP and the other terminal to V_{CCP} . If the PLL is not used, PCAP may be tied to V_{CC} , GND, or left floating. |
| PINIT/ \overline{NMI} | Input | Input | PLL Initial/Non maskable Interrupt —During assertion of \overline{RESET} , the value of PINIT/ \overline{NMI} is written into the PLL Enable (PEN) bit of the PLL control register, determining whether the PLL is enabled or disabled. After \overline{RESET} deassertion and during normal instruction processing, the PINIT/ \overline{NMI} Schmitt-trigger input is a negative-edge-triggered non maskable interrupt (NMI) request internally synchronized to CLKOUT. <i>PINIT/\overline{NMI} cannot tolerate 5 V.</i> |

2.5 External Memory Expansion Port (Port A)

When the DSP56362 enters a low-power standby mode (stop or wait), it releases bus mastership and tri-states the relevant port A signals: A0–A17, D0–D23, AA0/ $\overline{RAS0}$ –AA3/ $\overline{RAS3}$, \overline{RD} , \overline{WR} , \overline{BB} , \overline{CAS} .

2.5.1 External Address Bus

Table 2-5 External Address Bus Signals

| Signal Name | Type | State during Reset | Signal Description |
|-------------|--------|--------------------|-----------------------------------------------------------------------------------------------------------------------------------------------------------------------------------------------------------------------------------------------------------------------------------------------------------------|
| A0–A17 | Output | Tri-Stated | Address Bus —When the DSP is the bus master, A0–A17 are active-high outputs that specify the address for external program and data memory accesses. Otherwise, the signals are tri-stated. To minimize power dissipation, A0–A17 do not change state when external memory spaces are not being accessed. |

2.5.2 External Data Bus

Table 2-6 External Data Bus Signals

| Signal Name | Type | State during Reset | Signal Description |
|-------------|--------------|--------------------|-------------------------------------------------------------------------------------------------------------------------------------------------------------------------------------------------------------------------------|
| D0–D23 | Input/Output | Tri-Stated | Data Bus —When the DSP is the bus master, D0–D23 are active-high, bidirectional input/outputs that provide the bidirectional data bus for external program and data memory accesses. Otherwise, D0–D23 are tri-stated. |

2.5.3 External Bus Control

Table 2-7 External Bus Control Signals

| Signal Name | Type | State during Reset | Signal Description |
|---------------------------------------------------|--------|--------------------|----------------------------------------------------------------------------------------------------------------------------------------------------------------------------------------------------------------------------------------------------------------------------------------------------------------------------------------------------------------------------------------------------------------------------------------------------------------------------------------------------------------------------------------------------------------------------------------------------------------------------------------------------------------------------------------------------------------------------------------------------------------------------------------------------------------------------------------------------------------------------------------------------------------------------------------------------------------------------------------------------------------------------------------------------------------------------------------------------------------------------------------------------------------------------------------------------------------------------------------------------------------------------------------------------------------------------------------------------------------------------------------------------------------------------------------------------------------------------------------------------------------------------------------------------------------------------------------------------------------------|
| AA0-AA3/ \overline{RA} $\overline{S0}$ -RAS3 | Output | Tri-Stated | Address Attribute or Row Address Strobe —When defined as AA, these signals can be used as chip selects or additional address lines. When defined as \overline{RAS} , these signals can be used as \overline{RAS} for DRAM interface. These signals are can be tri-stated outputs with programmable polarity. |
| \overline{CAS} | Output | Tri-Stated | Column Address Strobe —When the DSP is the bus master, \overline{CAS} is an active-low output used by DRAM to strobe the column address. Otherwise, if the bus mastership enable (BME) bit in the DRAM control register is cleared, the signal is tri-stated. |
| \overline{RD} | Output | Tri-Stated | Read Enable —When the DSP is the bus master, \overline{RD} is an active-low output that is asserted to read external memory on the data bus (D0–D23). Otherwise, \overline{RD} is tri-stated. |
| \overline{WR} | Output | Tri-Stated | Write Enable —When the DSP is the bus master, \overline{WR} is an active-low output that is asserted to write external memory on the data bus (D0–D23). Otherwise, the signals are tri-stated. |
| \overline{TA} | Input | Ignored Input | <p>Transfer Acknowledge—If the DSP56362 is the bus master and there is no external bus activity, or the DSP56362 is not the bus master, the \overline{TA} input is ignored. The \overline{TA} input is a data transfer acknowledge (DTACK) function that can extend an external bus cycle indefinitely. Any number of wait states (1, 2, . . . infinity) may be added to the wait states inserted by the BCR by keeping \overline{TA} deasserted. In typical operation, \overline{TA} is deasserted at the start of a bus cycle, is asserted to enable completion of the bus cycle, and is deasserted before the next bus cycle. The current bus cycle completes one clock period after \overline{TA} is asserted synchronous to CLKOUT. The number of wait states is determined by the \overline{TA} input or by the bus control register (BCR), whichever is longer. The BCR can be used to set the minimum number of wait states in external bus cycles.</p> <p>In order to use the \overline{TA} functionality, the BCR must be programmed to at least one wait state. A zero wait state access cannot be extended by \overline{TA} deassertion, otherwise improper operation may result. \overline{TA} can operate synchronously or asynchronously, depending on the setting of the TAS bit in the operating mode register (OMR).</p> <p>\overline{TA} functionality may not be used while performing DRAM type accesses, otherwise improper operation may result.</p> |

Table 2-7 External Bus Control Signals (continued)

| Signal Name | Type | State during Reset | Signal Description |
|-----------------|--------------|---------------------|-------------------------------------------------------------------------------------------------------------------------------------------------------------------------------------------------------------------------------------------------------------------------------------------------------------------------------------------------------------------------------------------------------------------------------------------------------------------------------------------------------------------------------------------------------------------------------------------------------------------------------------------------------------------------------------------------------------------------------------------------------------------------------------------------------------------------------------------------------------------------------------------------------------------------------------------------------------------------------------------------------------------------------------------------------------------------------------------------------------------------------------------------------------------------------------------------------------------------------------------|
| \overline{BR} | Output | Output (deasserted) | <p>Bus Request—\overline{BR} is an active-low output, never tri-stated. \overline{BR} is asserted when the DSP requests bus mastership. \overline{BR} is deasserted when the DSP no longer needs the bus. \overline{BR} may be asserted or deasserted independent of whether the DSP56362 is a bus master or a bus slave. Bus “parking” allows \overline{BR} to be deasserted even though the DSP56362 is the bus master. (See the description of bus “parking” in the \overline{BB} signal description.) The bus request hold (BRH) bit in the BCR allows \overline{BR} to be asserted under software control even though the DSP does not need the bus. \overline{BR} is typically sent to an external bus arbitrator that controls the priority, parking, and tenure of each master on the same external bus. \overline{BR} is only affected by DSP requests for the external bus, never for the internal bus. During hardware reset, \overline{BR} is deasserted and the arbitration is reset to the bus slave state.</p> |
| \overline{BG} | Input | Ignored Input | <p>Bus Grant—\overline{BG} is an active-low input. \overline{BG} is asserted by an external bus arbitration circuit when the DSP56362 becomes the next bus master. When \overline{BG} is asserted, the DSP56362 must wait until \overline{BB} is deasserted before taking bus mastership. When \overline{BG} is deasserted, bus mastership is typically given up at the end of the current bus cycle. This may occur in the middle of an instruction that requires more than one external bus cycle for execution. The default mode of operation of this signal requires a setup and hold time referred to CLKOUT. But CLKOUT operation is not guaranteed from 100MHz and up, so the asynchronous bus arbitration must be used for clock frequencies 100MHz and above. The asynchronous bus arbitration is enabled by setting the ABE bit in the OMR register.</p> |
| \overline{BB} | Input/Output | Input | <p>Bus Busy—\overline{BB} is a bidirectional active-low input/output. \overline{BB} indicates that the bus is active. Only after \overline{BB} is deasserted can the pending bus master become the bus master (and then assert the signal again). The bus master may keep \overline{BB} asserted after ceasing bus activity regardless of whether \overline{BR} is asserted or deasserted. This is called “bus parking” and allows the current bus master to reuse the bus without re-arbitration until another device requires the bus. The deassertion of \overline{BB} is done by an “active pull-up” method (i.e., \overline{BB} is driven high and then released and held high by an external pull-up resistor). The default mode of operation of this signal requires a setup and hold time referred to CLKOUT. But CLKOUT operation is not guaranteed from 100MHz and up, so the asynchronous bus arbitration must be used for clock frequencies 100MHz and above. The asynchronous bus arbitration is enabled by setting the ABE bit in the OMR register. \overline{BB} requires an external pull-up resistor.</p> |

2.6 Interrupt and Mode Control

The interrupt and mode control signals select the chip’s operating mode as it comes out of hardware reset. After $\overline{\text{RESET}}$ is deasserted, these inputs are hardware interrupt request lines.

Table 2-8 Interrupt and Mode Control

| Signal Name | Type | State during Reset | Signal Description |
|--------------------------------|-------|--------------------|---------------------------------------------------------------------------------------------------------------------------------------------------------------------------------------------------------------------------------------------------------------------------------------------------------------------------------------------------------------------------------------------------------------------------------------------------------------------------------------------------------------------------------------------------------------------------------------------------------------------------------------------------------------------------------------------------------------------------------------------------------------------------------------------------------------------------------------------------------------------------------------------------------------------------------------------|
| MODA/ $\overline{\text{IRQA}}$ | Input | Input | Mode Select A/External Interrupt Request A —MODA/ $\overline{\text{IRQA}}$ is an active-low Schmitt-trigger input, internally synchronized to the DSP clock. MODA/ $\overline{\text{IRQA}}$ selects the initial chip operating mode during hardware reset and becomes a level-sensitive or negative-edge-triggered, maskable interrupt request input during normal instruction processing. MODA, MODB, MODC, and MODD select one of 16 initial chip operating modes, latched into the OMR when the $\overline{\text{RESET}}$ signal is deasserted. If $\overline{\text{IRQA}}$ is asserted synchronous to CLKOUT, multiple processors can be resynchronized using the WAIT instruction and asserting $\overline{\text{IRQA}}$ to exit the wait state. If the processor is in the stop standby state and the MODA/ $\overline{\text{IRQA}}$ pin is pulled to GND, the processor will exit the stop state. This input is 5 V tolerant. |
| MODB/ $\overline{\text{IRQB}}$ | Input | Input | Mode Select B/External Interrupt Request B —MODB/ $\overline{\text{IRQB}}$ is an active-low Schmitt-trigger input, internally synchronized to the DSP clock. MODB/ $\overline{\text{IRQB}}$ selects the initial chip operating mode during hardware reset and becomes a level-sensitive or negative-edge-triggered, maskable interrupt request input during normal instruction processing. MODA, MODB, MODC, and MODD select one of 16 initial chip operating modes, latched into OMR when the $\overline{\text{RESET}}$ signal is deasserted. If $\overline{\text{IRQB}}$ is asserted synchronous to CLKOUT, multiple processors can be re-synchronized using the WAIT instruction and asserting $\overline{\text{IRQB}}$ to exit the wait state. This input is 5 V tolerant. |
| MODC/ $\overline{\text{IRQC}}$ | Input | Input | Mode Select C/External Interrupt Request C —MODC/ $\overline{\text{IRQC}}$ is an active-low Schmitt-trigger input, internally synchronized to the DSP clock. MODC/ $\overline{\text{IRQC}}$ selects the initial chip operating mode during hardware reset and becomes a level-sensitive or negative-edge-triggered, maskable interrupt request input during normal instruction processing. MODA, MODB, MODC, and MODD select one of 16 initial chip operating modes, latched into OMR when the $\overline{\text{RESET}}$ signal is deasserted. If $\overline{\text{IRQC}}$ is asserted synchronous to CLKOUT, multiple processors can be resynchronized using the WAIT instruction and asserting $\overline{\text{IRQC}}$ to exit the wait state. This input is 5 V tolerant. |

Table 2-8 Interrupt and Mode Control (continued)

| Signal Name | Type | State during Reset | Signal Description |
|--------------------------------|-------|--------------------|---------------------------------------------------------------------------------------------------------------------------------------------------------------------------------------------------------------------------------------------------------------------------------------------------------------------------------------------------------------------------------------------------------------------------------------------------------------------------------------------------------------------------------------------------------------------------------------------------------------------------------------------------------------------------------------------------------------------------------------------------------------------------------------------------------------------------------------------------------------------------------------------------------------------|
| MODD/ $\overline{\text{IRQD}}$ | Input | Input | <p>Mode Select D/External Interrupt Request D—MODD/$\overline{\text{IRQD}}$ is an active-low Schmitt-trigger input, internally synchronized to the DSP clock. MODD/$\overline{\text{IRQD}}$ selects the initial chip operating mode during hardware reset and becomes a level-sensitive or negative-edge-triggered, maskable interrupt request input during normal instruction processing. MODA, MODB, MODC, and MODD select one of 16 initial chip operating modes, latched into OMR when the $\overline{\text{RESET}}$ signal is deasserted. If $\overline{\text{IRQD}}$ is asserted synchronous to CLKOUT, multiple processors can be resynchronized using the WAIT instruction and asserting $\overline{\text{IRQD}}$ to exit the wait state.</p> <p>This input is 5 V tolerant.</p> |
| $\overline{\text{RESET}}$ | Input | Input | <p>Reset—$\overline{\text{RESET}}$ is an active-low, Schmitt-trigger input. When asserted, the chip is placed in the reset state and the internal phase generator is reset. The Schmitt-trigger input allows a slowly rising input (such as a capacitor charging) to reset the chip reliably. If $\overline{\text{RESET}}$ is deasserted synchronous to CLKOUT, exact start-up timing is guaranteed, allowing multiple processors to start synchronously and operate together in “lock-step.” When the $\overline{\text{RESET}}$ signal is deasserted, the initial chip operating mode is latched from the MODA, MODB, MODC, and MODD inputs. The $\overline{\text{RESET}}$ signal must be asserted during power up. A stable EXTAL signal must be supplied while $\overline{\text{RESET}}$ is being asserted.</p> <p>This input is 5 V tolerant.</p> |

2.7 Host Interface (HDI08)

The HDI08 provides a fast, 8-bit, parallel data port that may be connected directly to the host bus. The HDI08 supports a variety of standard buses and can be directly connected to a number of industry standard microcomputers, microprocessors, DSPs, and DMA hardware.

2.7.1 Host Port Configuration

Signal functions associated with the HDI08 vary according to the interface operating mode as determined by the HDI08 port control register (HPCR). See **6.5.6 Host Port Control Register (HPCR)** on page Section 6-13 for detailed descriptions of this register and (See **Host Interface (HDI08)** on page Section 6-1.) for descriptions of the other HDI08 configuration registers.

Table 2-9 Host Interface

| Signal Name | Type | State during Reset | Signal Description |
|------------------------------|--------------------------------|--------------------|---------------------------------------------------------------------------------------------------------------------------------------------------------------------------------------------------------------------------------------------------------------------------------------------------------------------------------------------------------------------------------------------------------------------------------------------------------------------------------------------------------------------------------------------------------------------------------------------------------------------------------------------------------------------------------------------------------------------------------------------------------------------------------------------------------|
| H0–H7 | Input/Output | GPIO Disconnected | <p>Host Data—When the HDI08 is programmed to interface a nonmultiplexed host bus and the HI function is selected, these signals are lines 0–7 of the bidirectional, tri-state data bus.</p> <p>Host Address—When HDI08 is programmed to interface a multiplexed host bus and the HI function is selected, these signals are lines 0–7 of the address/data bidirectional, multiplexed, tri-state bus.</p> <p>Port B 0–7—When the HDI08 is configured as GPIO, these signals are individually programmable as input, output, or internally disconnected.</p> <p>The default state after reset for these signals is GPIO disconnected.</p> <p>This input is 5 V tolerant.</p> |
| HAD0–HAD7 | Input/Output | | |
| PB0–PB7 | Input, Output, or Disconnected | | |
| HA0 | Input | GPIO Disconnected | <p>Host Address Input 0—When the HDI08 is programmed to interface a nonmultiplexed host bus and the HI function is selected, this signal is line 0 of the host address input bus.</p> <p>Host Address Strobe—When HDI08 is programmed to interface a multiplexed host bus and the HI function is selected, this signal is the host address strobe (HAS) Schmitt-trigger input. The polarity of the address strobe is programmable, but is configured active-low ($\overline{\text{HAS}}$) following reset.</p> <p>Port B 8—When the HDI08 is configured as GPIO, this signal is individually programmed as input, output, or internally disconnected.</p> <p>The default state after reset for this signal is GPIO disconnected.</p> <p>This input is 5 V tolerant.</p> |
| $\overline{\text{HAS}}$ /HAS | Input | | |
| PB8 | Input, output, or disconnected | | |
| HA1 | Input | GPIO Disconnected | <p>Host Address Input 1—When the HDI08 is programmed to interface a nonmultiplexed host bus and the HI function is selected, this signal is line 1 of the host address (HA1) input bus.</p> <p>Host Address 8—When HDI08 is programmed to interface a multiplexed host bus and the HI function is selected, this signal is line 8 of the host address (HA8) input bus.</p> <p>Port B 9—When the HDI08 is configured as GPIO, this signal is individually programmed as input, output, or internally disconnected.</p> <p>The default state after reset for this signal is GPIO disconnected.</p> <p>This input is 5 V tolerant.</p> |
| HA8 | Input | | |
| PB9 | Input, Output, or Disconnected | | |

Table 2-9 Host Interface (continued)

| Signal Name | Type | State during Reset | Signal Description |
|------------------------------|--------------------------------|--------------------|--------------------------------------------------------------------------------------------------------------------------------------------------------------------------------------------------------------------------------------------------------------------------------------------------------------------------------------------------------------------------------------------------------------------------------------------------------------------------------------------------------------------------------------------------------------------------------------------------------------------------------------------------------------------------------------------------------------------------------------------------------------------------------------------------------------------------------------------------------------------------------------------------------------------------------------------------------|
| HA2 | Input | GPIO Disconnected | <p>Host Address Input 2—When the HDI08 is programmed to interface a non-multiplexed host bus and the HI function is selected, this signal is line 2 of the host address (HA2) input bus.</p> <p>Host Address 9—When HDI08 is programmed to interface a multiplexed host bus and the HI function is selected, this signal is line 9 of the host address (HA9) input bus.</p> <p>Port B 10—When the HDI08 is configured as GPIO, this signal is individually programmed as input, output, or internally disconnected.</p> <p>The default state after reset for this signal is GPIO disconnected. This input is 5 V tolerant.</p> |
| HA9 | Input | | |
| PB10 | Input, Output, or Disconnected | | |
| HRW | Input | GPIO Disconnected | <p>Host Read/Write—When HDI08 is programmed to interface a single-data-strobe host bus and the HI function is selected, this signal is the Host Read/Write (HRW) input.</p> <p>Host Read Data—When HDI08 is programmed to interface a double-data-strobe host bus and the HI function is selected, this signal is the host read data strobe (HRD) Schmitt-trigger input. The polarity of the data strobe is programmable, but is configured as active-low ($\overline{\text{HRD}}$) after reset.</p> <p>Port B 11—When the HDI08 is configured as GPIO, this signal is individually programmed as input, output, or internally disconnected.</p> <p>The default state after reset for this signal is GPIO disconnected. This input is 5 V tolerant.</p> |
| $\overline{\text{HRD}}$ /HRD | Input | | |
| PB11 | Input, Output, or Disconnected | | |
| $\overline{\text{HDS}}$ /HDS | Input | GPIO Disconnected | <p>Host Data Strobe—When HDI08 is programmed to interface a single-data-strobe host bus and the HI function is selected, this signal is the host data strobe (HDS) Schmitt-trigger input. The polarity of the data strobe is programmable, but is configured as active-low ($\overline{\text{HDS}}$) following reset.</p> <p>Host Write Data—When HDI08 is programmed to interface a double-data-strobe host bus and the HI function is selected, this signal is the host write data strobe (HWR) Schmitt-trigger input. The polarity of the data strobe is programmable, but is configured as active-low ($\overline{\text{HWR}}$) following reset.</p> <p>Port B 12—When the HDI08 is configured as GPIO, this signal is individually programmed as input, output, or internally disconnected.</p> <p>The default state after reset for this signal is GPIO disconnected. This input is 5 V tolerant.</p> |
| $\overline{\text{HWR}}$ /HWR | Input | | |
| PB12 | Input, Output, or Disconnected | | |

Table 2-9 Host Interface (continued)

| Signal Name | Type | State during Reset | Signal Description |
|-------------|--------------------------------|--------------------|---------------------------------------------------------------------------------------------------------------------------------------------------------------------------------------------------------------------------------------------------------------------------------------------------------------------------------------------------------------------------------------------------------------------------------------------------------------------------------------------------------------------------------------------------------------------------------------------------------------------------------------------------------------------------------------------------------------------------------------------------------------------|
| HCS | Input | GPIO Disconnected | <p>Host Chip Select—When HDI08 is programmed to interface a nonmultiplexed host bus and the HI function is selected, this signal is the host chip select (HCS) input. The polarity of the chip select is programmable, but is configured active-low ($\overline{\text{HCS}}$) after reset.</p> <p>Host Address 10—When HDI08 is programmed to interface a multiplexed host bus and the HI function is selected, this signal is line 10 of the host address (HA10) input bus.</p> <p>Port B 13—When the HDI08 is configured as GPIO, this signal is individually programmed as input, output, or internally disconnected.</p> <p>The default state after reset for this signal is GPIO disconnected. This input is 5 V tolerant.</p> |
| HA10 | Input | | |
| PB13 | Input, Output, or Disconnected | | |

Table 2-9 Host Interface (continued)

| Signal Name | Type | State during Reset | Signal Description |
|---------------------------------------|--------------------------------|--------------------|---------------------------------------------------------------------------------------------------------------------------------------------------------------------------------------------------------------------------------------------------------------------------------------------------------------------------------------------------------------------------------------------------------------------------------------------------------------------------------------------------------------------------------------------------------------------------------------------------------------------------------------------------------------------------------------------------------------------------------------------------------------------------------------------------------------------------------------------------------------------------------------------------------------------------------------------------------------------------------------------------------------------------------------------------------------------------|
| $\overline{\text{HOREQ}}/\text{HORE}$ | Output | GPIO Disconnected | <p>Host Request—When HDI08 is programmed to interface a single host request host bus and the HI function is selected, this signal is the host request (HOREQ) output. The polarity of the host request is programmable, but is configured as active-low ($\overline{\text{HOREQ}}$) following reset. The host request may be programmed as a driven or open-drain output.</p> <p>Transmit Host Request—When HDI08 is programmed to interface a double host request host bus and the HI function is selected, this signal is the transmit host request (HTRQ) output. The polarity of the host request is programmable, but is configured as active-low ($\overline{\text{HTRQ}}$) following reset. The host request may be programmed as a driven or open-drain output.</p> <p>Port B 14—When the HDI08 is configured as GPIO, this signal is individually programmed as input, output, or internally disconnected.</p> <p>The default state after reset for this signal is GPIO disconnected. This input is 5 V tolerant.</p> |
| $\overline{\text{HTRQ}}/\text{HTRQ}$ | Output | | |
| PB14 | Input, Output, or Disconnected | | |
| $\overline{\text{HACK}}/\text{HACK}$ | Input | GPIO Disconnected | <p>Host Acknowledge—When HDI08 is programmed to interface a single host request host bus and the HI function is selected, this signal is the host acknowledge (HACK) Schmitt-trigger input. The polarity of the host acknowledge is programmable, but is configured as active-low ($\overline{\text{HACK}}$) after reset.</p> <p>Receive Host Request—When HDI08 is programmed to interface a double host request host bus and the HI function is selected, this signal is the receive host request (HRRQ) output. The polarity of the host request is programmable, but is configured as active-low ($\overline{\text{HRRQ}}$) after reset. The host request may be programmed as a driven or open-drain output.</p> <p>Port B 15—When the HDI08 is configured as GPIO, this signal is individually programmed as input, output, or internally disconnected.</p> <p>The default state after reset for this signal is GPIO disconnected. This input is 5 V tolerant.</p> |
| $\overline{\text{HRRQ}}/\text{HRRQ}$ | Output | | |
| PB15 | Input, Output, or Disconnected | | |

2.8 Serial Host Interface

The SHI has five I/O signals that can be configured to allow the SHI to operate in either SPI or I²C mode.

Table 2-10 Serial Host Interface Signals

| Signal Name | Signal Type | State during Reset | Signal Description |
|-------------|----------------------------|--------------------|---------------------------------------------------------------------------------------------------------------------------------------------------------------------------------------------------------------------------------------------------------------------------------------------------------------------------------------------------------------------------------------------------------------------------------------------------------------------------------------------------------------------------------------------------------------------------------------------------------------------------------------------------------------------------------------------------------------------------------------------------------------------------------------------------------------------------------------------------------------------------------------------------------------------------------------------------------------------------------|
| SCK | Input or Output | Tri-Stated | <p>SPI Serial Clock—The SCK signal is an output when the SPI is configured as a master and a Schmitt-trigger input when the SPI is configured as a slave. When the SPI is configured as a master, the SCK signal is derived from the internal SHI clock generator. When the SPI is configured as a slave, the SCK signal is an input, and the clock signal from the external master synchronizes the data transfer. The SCK signal is ignored by the SPI if it is defined as a slave and the slave select (\overline{SS}) signal is not asserted. In both the master and slave SPI devices, data is shifted on one edge of the SCK signal and is sampled on the opposite edge where data is stable. Edge polarity is determined by the SPI transfer protocol.</p> |
| SCL | Input or Output | Tri-Stated | <p>I²C Serial Clock—SCL carries the clock for I²C bus transactions in the I²C mode. SCL is a Schmitt-trigger input when configured as a slave and an open-drain output when configured as a master. SCL should be connected to V_{CC} through a pull-up resistor.</p> <p>This signal is tri-stated during hardware, software, and individual reset. Thus, there is no need for an external pull-up in this state.</p> <p>This input is 5 V tolerant.</p> |
| MISO | Input or Output | Tri-Stated | <p>SPI Master-In-Slave-Out—When the SPI is configured as a master, MISO is the master data input line. The MISO signal is used in conjunction with the MOSI signal for transmitting and receiving serial data. This signal is a Schmitt-trigger input when configured for the SPI Master mode, an output when configured for the SPI Slave mode, and tri-stated if configured for the SPI Slave mode when \overline{SS} is deasserted. An external pull-up resistor is not required for SPI operation.</p> |
| SDA | Input or Open-Drain Output | Tri-Stated | <p>I²C Data and Acknowledge—In I²C mode, SDA is a Schmitt-trigger input when receiving and an open-drain output when transmitting. SDA should be connected to V_{CC} through a pull-up resistor. SDA carries the data for I²C transactions. The data in SDA must be stable during the high period of SCL. The data in SDA is only allowed to change when SCL is low. When the bus is free, SDA is high. The SDA line is only allowed to change during the time SCL is high in the case of start and stop events. A high-to-low transition of the SDA line while SCL is high is a unique situation, and is defined as the start event. A low-to-high transition of SDA while SCL is high is a unique situation defined as the stop event.</p> <p>This signal is tri-stated during hardware, software, and individual reset. Thus, there is no need for an external pull-up in this state.</p> <p>This input is 5 V tolerant.</p> |

Table 2-10 Serial Host Interface Signals (continued)

| Signal Name | Signal Type | State during Reset | Signal Description |
|-------------------|-----------------|--------------------|---------------------------------------------------------------------------------------------------------------------------------------------------------------------------------------------------------------------------------------------------------------------------------------------------------------------------------------------------------------------------------------------------------------------------------------------------------------------------------------------------------------------------------------------------------------------------------------------------------------------------------------------------------------------------------------------------------------------------------------------------------------------------------------------------------------------------------------------------------------------------------------------------------------------------------------------------------------------------------------|
| MOSI | Input or Output | Tri-Stated | <p>SPI Master-Out-Slave-In—When the SPI is configured as a master, MOSI is the master data output line. The MOSI signal is used in conjunction with the MISO signal for transmitting and receiving serial data. MOSI is the slave data input line when the SPI is configured as a slave. This signal is a Schmitt-trigger input when configured for the SPI Slave mode.</p> |
| HA0 | Input | Tri-Stated | <p>I²C Slave Address 0—This signal uses a Schmitt-trigger input when configured for the I²C mode. When configured for I²C slave mode, the HA0 signal is used to form the slave device address. HA0 is ignored when configured for the I²C master mode.</p> <p>This signal is tri-stated during hardware, software, and individual reset. Thus, there is no need for an external pull-up in this state.</p> <p>This input is 5 V tolerant.</p> |
| \overline{SS} | Input | Tri-Stated | <p>SPI Slave Select—This signal is an active low Schmitt-trigger input when configured for the SPI mode. When configured for the SPI Slave mode, this signal is used to enable the SPI slave for transfer. When configured for the SPI master mode, this signal should be kept deasserted (pulled high). If it is asserted while configured as SPI master, a bus error condition is flagged. If \overline{SS} is deasserted, the SHI ignores SCK clocks and keeps the MISO output signal in the high-impedance state.</p> |
| HA2 | Input | Tri-Stated | <p>I²C Slave Address 2—This signal uses a Schmitt-trigger input when configured for the I²C mode. When configured for the I²C Slave mode, the HA2 signal is used to form the slave device address. HA2 is ignored in the I²C master mode.</p> <p>This signal is tri-stated during hardware, software, and individual reset. Thus, there is no need for an external pull-up in this state.</p> <p>This input is 5 V tolerant.</p> |
| \overline{HREQ} | Input or Output | Tri-Stated | <p>Host Request—This signal is an active low Schmitt-trigger input when configured for the master mode but an active low output when configured for the slave mode.</p> <p>When configured for the slave mode, \overline{HREQ} is asserted to indicate that the SHI is ready for the next data word transfer and deasserted at the first clock pulse of the new data word transfer. When configured for the master mode, \overline{HREQ} is an input. When asserted by the external slave device, it will trigger the start of the data word transfer by the master. After finishing the data word transfer, the master will await the next assertion of \overline{HREQ} to proceed to the next transfer.</p> <p>This signal is tri-stated during hardware, software, personal reset, or when the HREQ1–HREQ0 bits in the HCSR are cleared. There is no need for external pull-up in this state.</p> <p>This input is 5 V tolerant.</p> |

2.9 Enhanced Serial Audio Interface

Table 2-11 Enhanced Serial Audio Interface Signals

| Signal Name | Signal Type | State during Reset | Signal Description |
|-------------|--------------------------------|--------------------|------------------------------------------------------------------------------------------------------------------------------------------------------------------------------------------------------------------------------------------------------------------------------------------------------------------------------------------------------------------------------------------------------------------------------------------------------------------------------------------------------------------------------------------------------------------------------------------------------------------------------------------------------------------------------------------------------------------------------------------------------------------------------------------------------------------------------------------------------------------------------------------------------------------------------------------------------------------------------------------------------------------------------------------------------------------------------------------------------------------------------------------------------------------------------------------------|
| HCKR | Input or Output | GPIO Disconnected | <p>High Frequency Clock for Receiver—When programmed as an input, this signal provides a high frequency clock source for the ESAI receiver as an alternate to the DSP core clock. When programmed as an output, this signal can serve as a high-frequency sample clock (e.g., for external digital to analog converters [DACs]) or as an additional system clock.</p> <p>Port C 2—When the ESAI is configured as GPIO, this signal is individually programmable as input, output, or internally disconnected. The default state after reset is GPIO disconnected. This input is 5 V tolerant.</p> |
| PC2 | Input, Output, or Disconnected | GPIO Disconnected | |
| HCKT | Input or Output | GPIO Disconnected | <p>High Frequency Clock for Transmitter—When programmed as an input, this signal provides a high frequency clock source for the ESAI transmitter as an alternate to the DSP core clock. When programmed as an output, this signal can serve as a high frequency sample clock (e.g., for external DACs) or as an additional system clock.</p> <p>Port C 5—When the ESAI is configured as GPIO, this signal is individually programmable as input, output, or internally disconnected. The default state after reset is GPIO disconnected. This input is 5 V tolerant.</p> |
| PC5 | Input, Output, or Disconnected | GPIO Disconnected | |
| FSR | Input or Output | GPIO Disconnected | <p>Frame Sync for Receiver—This is the receiver frame sync input/output signal. In the asynchronous mode (SYN=0), the FSR pin operates as the frame sync input or output used by all the enabled receivers. In the synchronous mode (SYN=1), it operates as either the serial flag 1 pin (TEBE=0), or as the transmitter external buffer enable control (TEBE=1, RFSD=1).</p> <p>When this pin is configured as serial flag pin, its direction is determined by the RFSD bit in the RCCR register. When configured as the output flag OF1, this pin will reflect the value of the OF1 bit in the SAICR register, and the data in the OF1 bit will show up at the pin synchronized to the frame sync in normal mode or the slot in network mode. When configured as the input flag IF1, the data value at the pin will be stored in the IF1 bit in the SAISR register, synchronized by the frame sync in normal mode or the slot in network mode.</p> <p>Port C 1—When the ESAI is configured as GPIO, this signal is individually programmable as input, output, or internally disconnected. The default state after reset is GPIO disconnected. This input is 5 V tolerant.</p> |
| PC1 | Input, Output, or Disconnected | GPIO Disconnected | |

Table 2-11 Enhanced Serial Audio Interface Signals (continued)

| Signal Name | Signal Type | State during Reset | Signal Description |
|-------------|--------------------------------|--------------------|-----------------------------------------------------------------------------------------------------------------------------------------------------------------------------------------------------------------------------------------------------------------------------------------------------------------------------------------------------------------------------------------------------------------------------------------------------------------------------------------------------------------------------------------------------------------------------------------------------------------------------------------------------------------------------------------------------------------------------------------------------------------------------------------------------------------------------------------------------------------------------------------------------------------------------------------------------------------------------------------------------------------------------------------------------------------------------------|
| FST | Input or Output | GPIO Disconnected | <p>Frame Sync for Transmitter—This is the transmitter frame sync input/output signal. For synchronous mode, this signal is the frame sync for both transmitters and receivers. For asynchronous mode, FST is the frame sync for the transmitters only. The direction is determined by the transmitter frame sync direction (TFSD) bit in the ESAI transmit clock control register (TCCR).</p> <p>Port C 4—When the ESAI is configured as GPIO, this signal is individually programmable as input, output, or internally disconnected. The default state after reset is GPIO disconnected. This input is 5 V tolerant.</p> |
| PC4 | Input, Output, or Disconnected | | |
| SCKR | Input or Output | GPIO Disconnected | <p>Receiver Serial Clock—SCKR provides the receiver serial bit clock for the ESAI. The SCKR operates as a clock input or output used by all the enabled receivers in the asynchronous mode (SYN=0), or as serial flag 0 pin in the synchronous mode (SYN=1).</p> <p>When this pin is configured as serial flag pin, its direction is determined by the RCKD bit in the RCCR register. When configured as the output flag OF0, this pin will reflect the value of the OF0 bit in the SAICR register, and the data in the OF0 bit will show up at the pin synchronized to the frame sync in normal mode or the slot in network mode. When configured as the input flag IF0, the data value at the pin will be stored in the IF0 bit in the SAISR register, synchronized by the frame sync in normal mode or the slot in network mode.</p> <p>Port C 0—When the ESAI is configured as GPIO, this signal is individually programmable as input, output, or internally disconnected. The default state after reset is GPIO disconnected. This input is 5 V tolerant.</p> |
| PC0 | Input, Output, or Disconnected | | |
| SCKT | Input or Output | GPIO Disconnected | <p>Transmitter Serial Clock—This signal provides the serial bit rate clock for the ESAI. SCKT is a clock input or output used by all enabled transmitters and receivers in synchronous mode, or by all enabled transmitters in asynchronous mode.</p> <p>Port C 3—When the ESAI is configured as GPIO, this signal is individually programmable as input, output, or internally disconnected. The default state after reset is GPIO disconnected. This input is 5 V tolerant.</p> |
| PC3 | Input, Output, or Disconnected | | |
| SDO5 | Output | GPIO Disconnected | <p>Serial Data Output 5—When programmed as a transmitter, SDO5 is used to transmit data from the TX5 serial transmit shift register.</p> <p>Serial Data Input 0—When programmed as a receiver, SDI0 is used to receive serial data into the RX0 serial receive shift register.</p> <p>Port C 6—When the ESAI is configured as GPIO, this signal is individually programmable as input, output, or internally disconnected. The default state after reset is GPIO disconnected. This input is 5 V tolerant.</p> |
| SDI0 | Input | | |
| PC6 | Input, Output, or Disconnected | | |

Table 2-11 Enhanced Serial Audio Interface Signals (continued)

| Signal Name | Signal Type | State during Reset | Signal Description |
|---------------------|---------------------------------------------------|--------------------|-------------------------------------------------------------------------------------------------------------------------------------------------------------------------------------------------------------------------------------------------------------------------------------------------------------------------------------------------------------------------------------------------------------------------------------------------------------------------------------------------------------------------------------|
| SDO4 SDI1 PC7 | Output Input Input, Output, or Disconnected | GPIO Disconnected | <p>Serial Data Output 4—When programmed as a transmitter, SDO4 is used to transmit data from the TX4 serial transmit shift register.</p> <p>Serial Data Input 1—When programmed as a receiver, SDI1 is used to receive serial data into the RX1 serial receive shift register.</p> <p>Port C 7—When the ESAI is configured as GPIO, this signal is individually programmable as input, output, or internally disconnected. The default state after reset is GPIO disconnected. This input is 5 V tolerant.</p> |
| SDO3 SDI2 PC8 | Output Input Input, Output, or Disconnected | GPIO Disconnected | <p>Serial Data Output 3—When programmed as a transmitter, SDO3 is used to transmit data from the TX3 serial transmit shift register.</p> <p>Serial Data Input 2—When programmed as a receiver, SDI2 is used to receive serial data into the RX2 serial receive shift register.</p> <p>Port C 8—When the ESAI is configured as GPIO, this signal is individually programmable as input, output, or internally disconnected. The default state after reset is GPIO disconnected. This input is 5 V tolerant.</p> |
| SDO2 SDI3 PC9 | Output Input Input, Output, or Disconnected | GPIO Disconnected | <p>Serial Data Output 2—When programmed as a transmitter, SDO2 is used to transmit data from the TX2 serial transmit shift register.</p> <p>Serial Data Input 3—When programmed as a receiver, SDI3 is used to receive serial data into the RX3 serial receive shift register.</p> <p>Port C 9—When the ESAI is configured as GPIO, this signal is individually programmable as input, output, or internally disconnected. The default state after reset is GPIO disconnected. This input is 5 V tolerant.</p> |
| SDO1 PC10 | Output Input, Output, or Disconnected | GPIO Disconnected | <p>Serial Data Output 1—SDO1 is used to transmit data from the TX1 serial transmit shift register.</p> <p>Port C 10—When the ESAI is configured as GPIO, this signal is individually programmable as input, output, or internally disconnected. The default state after reset is GPIO disconnected. This input is 5 V tolerant.</p> |
| SDO0 PC11 | Output Input, Output, or Disconnected | GPIO Disconnected | <p>Serial Data Output 0—SDO0 is used to transmit data from the TX0 serial transmit shift register.</p> <p>Port C 11—When the ESAI is configured as GPIO, this signal is individually programmable as input, output, or internally disconnected. The default state after reset is GPIO disconnected. This input is 5 V tolerant.</p> |

2.10 Digital Audio Interface (DAX)

Table 2-12 Digital Audio Interface (DAX) Signals

| Signal Name | Type | State During Reset | Signal Description |
|-------------|--------------------------------|--------------------|-------------------------------------------------------------------------------------------------------------------------------------------------------------------------------------------------------------------------------------------------------------------------------------------------------------------------------------------------------------------------------------------------------------------------------------------------------------------------------------------------------------------------------------------------------------------------------|
| ACI | Input | Disconnected | <p>Audio Clock Input—This is the DAX clock input. When programmed to use an external clock, this input supplies the DAX clock. The external clock frequency must be 256, 384, or 512 times the audio sampling frequency ($256 \times F_s$, $384 \times F_s$ or $512 \times F_s$, respectively).</p> <p>Port D 0—When the DAX is configured as GPIO, this signal is individually programmable as input, output, or internally disconnected. The default state after reset is GPIO disconnected. This input is 5 V tolerant.</p> |
| PD0 | Input, Output, or Disconnected | Disconnected | |
| ADO | Output | Disconnected | <p>Digital Audio Data Output—This signal is an audio and non-audio output in the form of AES/EBU, CP340 and IEC958 data in a biphasic mark format.</p> <p>Port D 1—When the DAX is configured as GPIO, this signal is individually programmable as input, output, or internally disconnected. The default state after reset is GPIO disconnected. This input is 5 V tolerant.</p> |
| PD1 | Input, Output, or Disconnected | Disconnected | |

2.11 Timer

Table 2-13 Timer Signal

| Signal Name | Type | State During Reset | Signal Description |
|-------------|-----------------|--------------------|----------------------------------------------------------------------------------------------------------------------------------------------------------------------------------------------------------------------------------------------------------------------------------------------------------------------------------------------------------------------------------------------------------------------------------------------------------------------------------------------------------------------------------------------------------------------------------------------------------------------------------------------------------------------------------------------------------------------------------------|
| TIO0 | Input or Output | Input | <p>Timer 0 Schmitt-Trigger Input/Output—When timer 0 functions as an external event counter or in measurement mode, TIO0 is used as input. When timer 0 functions in watchdog, timer, or pulse modulation mode, TIO0 is used as output.</p> <p>The default mode after reset is GPIO input. This can be changed to output or configured as a timer input/output through the timer 0 control/status register (TCSR0). If TIO0 is not being used, it is recommended to either define it as GPIO output immediately at the beginning of operation or leave it defined as GPIO input but connected it to Vcc through a pull-up resistor in order to ensure a stable logic level at the input.</p> <p>This input is 5 V tolerant.</p> |

2.12 JTAG/OnCE Interface

Table 2-14 JTAG/OnCE™ Interface

| Signal Name | Type | State During Reset | Signal Description |
|--------------------------|--------------|--------------------|----------------------------------------------------------------------------------------------------------------------------------------------------------------------------------------------------------------------------------------------------------------------------------------------------------------------------------------------------------------------------------------------------------------------------------------------------------------------------------------------------------------------------------------------------------------------------------------------------------------------------------------------------------------------------------------------------------------------------------------------------------------------------------------------------------------------------------------------------------------------------------------------------------------------------------------------------------------------------------------------------------------------------------------------------------------------------------------------------------------------------------------------------------------------------------------------------------------------------------------------------------------------------------------------------------------------------------------------------------------------|
| TCK | Input | Input | <p>Test Clock—TCK is a test clock input signal used to synchronize the JTAG test logic. It has an internal pull-up resistor.</p> <p>This input is 5 V tolerant.</p> |
| TDI | Input | Input | <p>Test Data Input—TDI is a test data serial input signal used for test instructions and data. TDI is sampled on the rising edge of TCK and has an internal pull-up resistor.</p> <p>This input is 5 V tolerant.</p> |
| TDO | Output | Tri-Stated | <p>Test Data Output—TDO is a test data serial output signal used for test instructions and data. TDO can be tri-stated and is actively driven in the shift-IR and shift-DR controller states. TDO changes on the falling edge of TCK.</p> |
| TMS | Input | Input | <p>Test Mode Select—TMS is an input signal used to sequence the test controller's state machine. TMS is sampled on the rising edge of TCK and has an internal pull-up resistor.</p> <p>This input is 5 V tolerant.</p> |
| $\overline{\text{TRST}}$ | Input | Input | <p>Test Reset—$\overline{\text{TRST}}$ is an active-low Schmitt-trigger input signal used to asynchronously initialize the test controller. $\overline{\text{TRST}}$ has an internal pull-up resistor.</p> <p>The use of $\overline{\text{TRST}}$ is not recommended for new designs. It is recommended to leave $\overline{\text{TRST}}$ disconnected.</p> <p>This input is 5 V tolerant.</p> |
| $\overline{\text{DE}}$ | Input/Output | Input | <p>Debug Event—$\overline{\text{DE}}$ is an open-drain, bidirectional, active-low signal providing, as an input, a means of entering the debug mode of operation from an external command controller, and, as an output, a means of acknowledging that the chip has entered the debug mode. This signal, when asserted as an input, causes the DSP56300 core to finish the current instruction being executed, save the instruction pipeline information, enter the debug mode, and wait for commands to be entered from the debug serial input line. This signal is asserted as an output for three clock cycles when the chip enters the debug mode as a result of a debug request or as a result of meeting a breakpoint condition. The $\overline{\text{DE}}$ has an internal pull-up resistor.</p> <p>This is not a standard part of the JTAG TAP controller. The signal connects directly to the OnCE module to initiate debug mode directly or to provide a direct external indication that the chip has entered the debug mode. All other interface with the OnCE module must occur through the JTAG port.</p> <p>The use of $\overline{\text{DE}}$ is not recommended for new designs. It is recommended to leave $\overline{\text{DE}}$ disconnected.</p> <p>This input is not 5 V tolerant.</p> |

3 Specifications

3.1 Introduction

The DSP56362 is fabricated in high density CMOS with Transistor-Transistor Logic (TTL) compatible inputs and outputs. The DSP56362 specifications are preliminary and are from design simulations, and may not be fully tested or guaranteed. Finalized specifications will be published after full characterization and device qualifications are complete.

3.2 Maximum Ratings

CAUTION

This device contains circuitry protecting against damage due to high static voltage or electrical fields. However, normal precautions should be taken to avoid exceeding maximum voltage ratings. Reliability of operation is enhanced if unused inputs are pulled to an appropriate logic voltage level (e.g., either GND or V_{CC}). The suggested value for a pullup or pulldown resistor is 10 k Ω .

NOTE

In the calculation of timing requirements, adding a maximum value of one specification to a minimum value of another specification does not yield a reasonable sum. A maximum specification is calculated using a worst case variation of process parameter values in one direction. The minimum specification is calculated using the worst case for the same parameters in the opposite direction. Therefore, a “maximum” value for a specification will never occur in the same device that has a “minimum” value for another specification; adding a maximum to a minimum represents a condition that can never exist.

Table 3-1 Maximum Ratings

| Rating ¹ | Symbol | Value ^{1, 2} | Unit |
|-----------------------------------------------------------------|-----------|-----------------------------|------|
| Supply Voltage | V_{CC} | -0.3 to +4.0 | V |
| All input voltages excluding “5 V tolerant” inputs ³ | V_{IN} | GND -0.3 to $V_{CC} + 0.3$ | V |
| All “5 V tolerant” input voltages ³ | V_{IN5} | GND -0.3 to $V_{CC} + 3.95$ | V |
| Current drain per pin excluding V_{CC} and GND | I | 10 | mA |

Thermal Characteristics

Table 3-1 Maximum Ratings (continued)

| Rating ¹ | Symbol | Value ^{1, 2} | Unit |
|-----------------------------|-----------|-----------------------|------|
| Operating temperature range | T_J | -40 to +105 | °C |
| Storage temperature | T_{STG} | -55 to +125 | °C |

¹ GND = 0 V, $V_{CC} = 3.3 \text{ V} \pm .16 \text{ V}$, $T_J = 0^\circ\text{C}$ to $+100^\circ\text{C}$, $C_L = 50 \text{ pF}$

² Absolute maximum ratings are stress ratings only, and functional operation at the maximum is not guaranteed. Stress beyond the maximum rating may affect device reliability or cause permanent damage to the device.

³ **CAUTION:** All “5 V Tolerant” input voltages must not be more than 3.95 V greater than the supply voltage; this restriction applies to “power on”, as well as during normal operation. In any case, the input voltages cannot be more than 5.75 V. “5 V Tolerant” inputs are inputs that tolerate 5 V.

3.3 Thermal Characteristics

Table 3-2 Thermal Characteristics

| Characteristic | Symbol | LQFP Value | Unit |
|-----------------------------------------------------|----------------------------------|------------|------|
| Junction-to-ambient thermal resistance ¹ | $R_{\theta JA}$ or θ_{JA} | 45.3 | °C/W |
| Junction-to-case thermal resistance ² | $R_{\theta JC}$ or θ_{JC} | 10.1 | °C/W |
| Thermal characterization parameter | Ψ_{JT} | 5.5 | °C/W |

¹ Junction-to-ambient thermal resistance is based on measurements on a horizontal single-sided printed circuit board per SEMI G38-87 in natural convection. (SEMI is Semiconductor Equipment and Materials International, 805 East Middlefield Rd., Mountain View, CA 94043, (415) 964-5111.

Measurements were done with parts mounted on thermal test boards conforming to specification EIA/JESD51-3.

² Junction-to-case thermal resistance is based on measurements using a cold plate per SEMI G30-88, with the exception that the cold plate temperature is used for the case temperature.

3.4 DC Electrical Characteristics

Table 3-3 DC Electrical Characteristics¹

| Characteristics | Symbol | Min | Typ | Max | Unit |
|---------------------------------------------------------------------------------------------------------------------------------------------------------------|-----------|----------------------------|-----|-----------------------------|------|
| Supply voltage | V_{CC} | 3.14 | 3.3 | 3.46 | V |
| Input high voltage | | | | | V |
| • D(0:23), \overline{BG} , \overline{BB} , \overline{TA} , \overline{DE} , and $\overline{PINIT}/\overline{NMI}$ | V_{IH} | 2.0 | — | V_{CC} | |
| • $\overline{MOD^2}/\overline{IRQ^2}$, \overline{RESET} , and TCK/TDI/TMS/ TRST/ESAI/Timer/HDI08/ SHI(SPI mode) pins | V_{IHP} | 2.0 | — | $V_{CC} + 3.95$ | |
| • SHI(I2C mode) pins • EXTAL ³ | V_{IHX} | 1.5 $0.8 \times V_{CC}$ | — | $V_{CC} + 3.95$ V_{CC} | |
| Input low voltage | | | | | V |
| • D(0:23), \overline{BG} , \overline{BB} , \overline{TA} , $\overline{MOD^2}/\overline{IRQ^2}$, \overline{RESET} , $\overline{PINIT}/\overline{NMI}$ | V_{IL} | -0.3 | — | 0.8 | |
| • All JTAG/ESAI/Timer/HDI08/ SHI(SPI mode) pins | V_{ILP} | -0.3 | — | 0.8 | |
| • SHI(I2C mode) pins | | -0.3 | — | $0.3 \times V_{CC}$ | |
| • EXTAL ³ | V_{ILX} | -0.3 | — | $0.2 \times V_{CC}$ | |

Table 3-3 DC Electrical Characteristics¹ (continued)

| Characteristics | Symbol | Min | Typ | Max | Unit |
|-----------------------------------------------------------------------------------------------------------------------------------------------------------------|-------------------------------------|------------------------|-------------------|------------------|---------|
| Input leakage current | I_{IN} | -10 | — | 10 | μA |
| High impedance (off-state) input current (@ 2.4 V / 0.4 V) | I_{TSI} | -10 | — | 10 | μA |
| Output high voltage • TTL ($I_{OH} = -0.4 \mu A$) ^{4, 5} • CMOS ($I_{OH} = -10 \mu A$) ⁴ | V_{OH} | 2.4 $V_{CC} - 0.01$ | — — | — | V |
| Output low voltage • TTL ($I_{OL} = 3.0 \mu A$, open-drain pins $I_{OL} = 6.7 \mu A$) ^{4, 5} • CMOS ($I_{OL} = 10 \mu A$) ⁴ | V_{OL} | — | — | 0.4 0.01 | V |
| Internal supply current ⁶ (Operating frequency 100MHz for current measurements) • In Normal mode • In Wait mode • In Stop mode ⁷ | I_{CCI} I_{CCW} I_{CCS} | — — — | 127 7.5 100 | 181 11 150 | μA |
| PLL supply current | | — | 1 | 2.5 | μA |
| Input capacitance ⁴ | C_{IN} | — | — | 10 | pF |

¹ $V_{CC} = 3.3 V \pm 5\% V$; $T_J = 0^\circ C$ to $+100^\circ C$, $C_L = 50 pF$

² Refers to MODA/ \overline{IRQA} , MODB/ \overline{IRQB} , MODC/ \overline{IRQC} , and MODD/ \overline{IRQD} pins.

³ Driving EXTAL to the low V_{IHx} or the high V_{ILx} value may cause additional power consumption (DC current). To minimize power consumption, the minimum V_{IHx} should be no lower than $0.9 V_{CC}$ and the maximum V_{ILx} should be no higher than $0.1 V_{CC}$.

⁴ Periodically sampled and not 100% tested.

⁵ This characteristic does not apply to PCAP.

⁶ [Section 5.3, "Power Consumption Considerations"](#) provides a formula to compute the estimated current requirements in Normal mode. In order to obtain these results, all inputs must be terminated (i.e., not allowed to float). Measurements are based on synthetic intensive DSP benchmarks. The power consumption numbers in this specification are 90% of the measured results of this benchmark. This reflects typical DSP applications. Typical internal supply current is measured with $V_{CC} = 3.3 V$ at $T_J = 100^\circ C$. Maximum internal supply current is measured with $V_{CC} = 3.46 V$ at $T_J = 100^\circ C$.

⁷ In order to obtain these results, all inputs, which are not disconnected at Stop mode, must be terminated (i.e., not allowed to float).

3.5 AC Electrical Characteristics

The timing waveforms shown in the AC electrical characteristics section are tested with a V_{IL} maximum of 0.3 V and a V_{IH} minimum of 2.4 V for all pins except EXTAL, which is tested using the input levels shown in Note 6 of the previous table. AC timing specifications, which are referenced to a device input signal, are measured in production with respect to the 50% point of the respective input signal's transition. DSP56362 output levels are measured with the production test machine V_{OL} and V_{OH} reference levels set at 0.4 V and 2.4 V, respectively.

NOTE

Although the minimum value for the frequency of EXTAL is 0 MHz, the device AC test conditions are 15 MHz and rated speed.

3.6 Internal Clocks

Table 3-4 Internal Clocks, CLKOUT

| Characteristics | Symbol | Expression ^{1, 2} | | |
|---------------------------------------------------------------------------------------------------------------------------------------------------------------------------------------------------------------------------|-----------|-----------------------------------------------------------------------------------------------|-----------------------------------|-----------------------------------------------------------------------------------------------|
| | | Min | Typ | Max |
| Internal operation frequency and CLKOUT with PLL enabled | f | — | $(E_f \times MF)/(PDF \times DF)$ | — |
| Internal operation frequency and CLKOUT with PLL disabled | f | — | $E_f/2$ | — |
| Internal clock and CLKOUT high period <ul style="list-style-type: none"> • With PLL disabled • With PLL enabled and $MF \leq 4$ • With PLL enabled and $MF > 4$ | T_H | — $0.49 \times ET_C \times PDF \times DF/MF$ $0.47 \times ET_C \times PDF \times DF/MF$ | ET_C — — | — $0.51 \times ET_C \times PDF \times DF/MF$ $0.53 \times ET_C \times PDF \times DF/MF$ |
| Internal clock and CLKOUT low period <ul style="list-style-type: none"> • With PLL disabled • With PLL enabled and $MF \leq 4$ • With PLL enabled and $MF > 4$ | T_L | — $0.49 \times ET_C \times PDF \times DF/MF$ $0.47 \times ET_C \times PDF \times DF/MF$ | ET_C — — | — $0.51 \times ET_C \times PDF \times DF/MF$ $0.53 \times ET_C \times PDF \times DF/MF$ |
| Internal clock and CLKOUT cycle time with PLL enabled | T_C | — | $ET_C \times PDF \times DF/MF$ | — |
| Internal clock and CLKOUT cycle time with PLL disabled | T_C | — | $2 \times ET_C$ | — |
| Instruction cycle time | I_{CYC} | — | T_C | — |

¹ DF = Division Factor
 Ef = External frequency
 ET_C = External clock cycle
 MF = Multiplication Factor
 PDF = Predivision Factor
 T_C = internal clock cycle

² See the PLL and Clock Generation section in the *DSP56300 Family Manual* for a detailed discussion of the PLL.

3.7 EXTERNAL CLOCK OPERATION

The DSP56362 system clock is an externally supplied square wave voltage source connected to EXTAL (Figure 3-1)

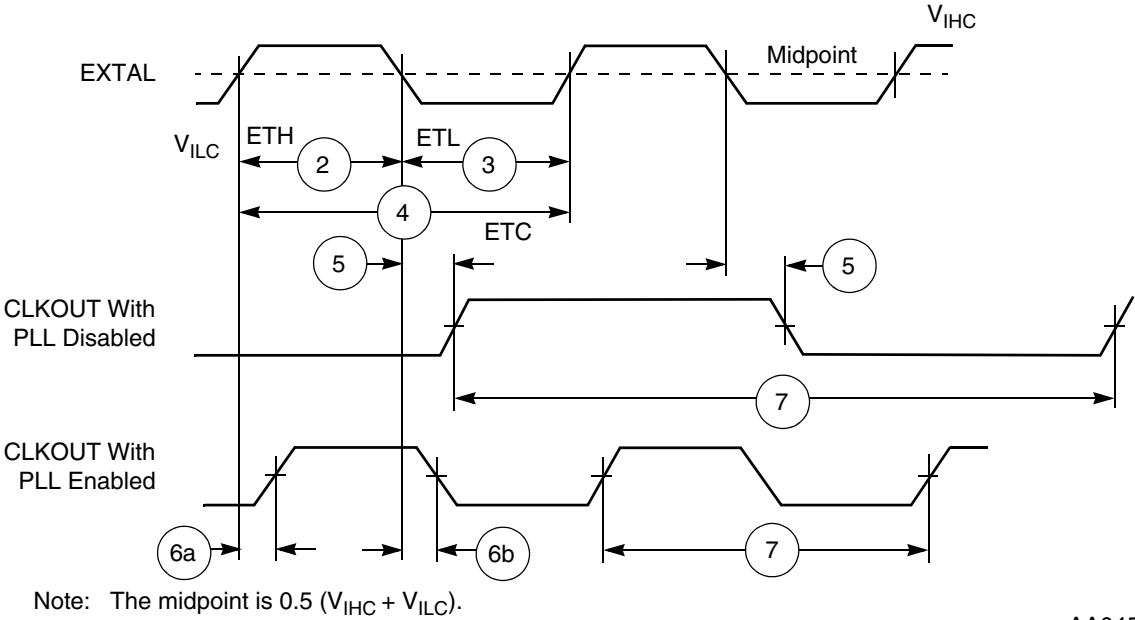

AA0459

Figure 3-1 External Clock Timing

Table 3-5 Clock Operation 100 and 120 MHz Values

| No. | Characteristics | Symbol | 100 MHz | | 120 MHz | |
|-----|-----------------------------------------------------------------------------------------------------------------------------------------------------------|--------|----------------------|---------------------------|--------------------|---------------------------|
| | | | Min | Max | Min | Max |
| 1 | Frequency of EXTAL (EXTAL Pin Frequency) The rise and fall time of this external clock should be 3 ns maximum. | E_f | 0 | 100.0 | 0 | 120.0 |
| 2 | EXTAL input high ^{1, 2} • With PLL disabled (46.7%–53.3% duty cycle) ³ • With PLL enabled (42.5%–57.5% duty cycle) ³ | ET_H | 4.67 ns 4.25 ns | ∞ 157.0 μ s | 0.00 ns 0.00 ns | ∞ 157.0 μ s |
| 3 | EXTAL input low ^{1, 2} • With PLL disabled (46.7%–53.3% duty cycle) ³ • With PLL enabled (42.5%–57.5% duty cycle) ³ | ET_L | 4.67 ns 4.25 ns | ∞ 157.0 μ s | 4.67 ns 4.25 ns | — 1570.00 |
| 4 | EXTAL cycle time ² • With PLL disabled • With PLL enabled | ET_C | 10.00 ns 10.00 ns | ∞ 273.1 μ s | 8.33 ns 8.33 ns | — 273.1 μ s |
| 5 | CLKOUT change from EXTAL fall with PLL disabled | | 4.3 ns | 11.0 ns | | |

Table 3-5 Clock Operation (continued) 100 and 120 MHz Values

| No. | Characteristics | Symbol | 100 MHz | | 120 MHz | |
|-----|-----------------------------------------------------------------------------------------------------------------------------------------------------------------------------------------------------------|-----------|---------|---------|---------|---------|
| | | | Min | Max | Min | Max |
| 6 | CLKOUT rising edge from EXTAL rising edge with PLL enabled (MF = 1, PDF = 1, Ef > 15 MHz) ^{4, 5} | | 0.0 ns | 1.8 ns | | |
| | CLKOUT falling edge from EXTAL rising edge with PLL enabled (MF = 2 or 4, PDF = 1, Ef > 15 MHz) ^{4, 5} | | 0.0 ns | 1.8 ns | | |
| | CLKOUT falling edge from EXTAL falling edge with PLL enabled (MF ≤ 4, PDF ≠ 1, Ef / PDF > 15 MHz) ^{4, 5} | | 0.0 ns | 1.8 ns | | |
| 7 | Instruction cycle time = $I_{CYC} = T_C^6$ See Table 3-5 (46.7%–53.3% duty cycle) <ul style="list-style-type: none"> • With PLL disabled • With PLL enabled | I_{CYC} | 0.00 ns | ∞ | | |
| | | | 0.00 ns | 8.53 μs | | 8.53 μs |

¹ Measured at 50% of the input transition.

² The maximum value for PLL enabled is given for minimum V_{CO} and maximum MF.

³ The indicated duty cycle is for the specified maximum frequency for which a part is rated. The minimum clock high or low time required for correction operation, however, remains the same at lower operating frequencies; therefore, when a lower clock frequency is used, the signal symmetry may vary from the specified duty cycle as long as the minimum high time and low time requirements are met.

⁴ Periodically sampled and not 100% tested.

⁵ The skew is not guaranteed for any other MF value.

⁶ The maximum value for PLL enabled is given for minimum V_{CO} and maximum DF.

3.8 Phase Lock Loop (PLL) Characteristics

Table 3-6 PLL Characteristics

| Characteristics | 100 MHz | | Unit |
|--------------------------------------------------------------------------------------------------------------------------------------------------------------------|------------------------------|-------------------------------|----------|
| | Min | Max | |
| V_{CO} frequency when PLL enabled ($MF \times E_f \times 2/PDF$) | 30 | 200 | MHz |
| PLL external capacitor (PCAP pin to V_{CCP}) (C_{PCAP}) ¹ <ul style="list-style-type: none"> • @ MF ≤ 4 • @ MF > 4 | (MF × 580) – 100 MF × 830 | (MF × 780) – 140 MF × 1470 | pF pF |
| Note: | | | |

¹ C_{PCAP} is the value of the PLL capacitor (connected between the PCAP pin and V_{CCP}). The recommended value in pF for C_{PCAP} can be computed from one of the following equations:

(680 × MF) – 120, for MF ≤ 4, or

1100 × MF, for MF > 4

3.9 Reset, Stop, Mode Select, and Interrupt Timing

Table 3-7 Reset, Stop, Mode Select, and Interrupt Timing 100 and 120 MHz Values¹

| No | Characteristics | Expression ² | 100 MHz | | 120 MHz | | Unit |
|---------------------------|---------------------------------------------------------------------------------------------------------------------------------------------------------------------------------------------------------------------------------------------------|-----------------------------------------------|-------------------------|-------|---------|-------|---------------|
| | | | Min | Max | Min | Max | |
| 8 | Delay from $\overline{\text{RESET}}$ assertion to all pins at reset value ³ | — | — | 26.0 | | 26.0 | ns |
| 9 | Required $\overline{\text{RESET}}$ duration ⁴ | | | | | | |
| | • Power on, external clock generator, PLL disabled | $50 \times ET_C$ | 500.0 | — | 416.7 | — | ns |
| | • Power on, external clock generator, PLL enabled | $1000 \times ET_C$ | 10.0 | — | 8.3 | — | μs |
| | • Power on, internal oscillator | $75000 \times ET_C$ | 750 | — | 625 | — | μs |
| | • During STOP, XTAL disabled (PCTL Bit 16 = 0) | $75000 \times ET_C$ | 750 | — | 625 | — | μs |
| | • During STOP, XTAL enabled (PCTL Bit 16 = 1) | $2.5 \times T_C$ | 25.0 | — | 20.8 | — | ns |
| • During normal operation | $2.5 \times T_C$ | 25.0 | — | 20.8 | — | ns | |
| 10 | Delay from asynchronous $\overline{\text{RESET}}$ deassertion to first external address output (internal reset deassertion) ⁵ | | | | | | |
| | | • Minimum | $3.25 \times T_C + 2.0$ | 34.5 | — | 29.1 | ns |
| | • Maximum | $20.25 T_C + 7.50$ | — | 211.5 | | 176.2 | ns |
| 11 | Synchronous reset setup time from $\overline{\text{RESET}}$ deassertion to CLKOUT Transition 1 | | | | | | |
| | | • Minimum | T_C | 5.9 | — | | ns |
| | • Maximum | | — | 10.0 | | | ns |
| 12 | Synchronous reset deasserted, delay time from the CLKOUT Transition 1 to the first external address output | | | | | | |
| | | • Minimum | $3.25 \times T_C + 2.0$ | 33.5 | — | | ns |
| | • Maximum | $20.25 T_C + 7.5$ | — | 207.5 | | | ns |
| 13 | Mode select setup time | | 30.0 | — | 30.0 | | ns |
| 14 | Mode select hold time | | 0.0 | — | 0.0 | | ns |
| 15 | Minimum edge-triggered interrupt request assertion width | | 6.6 | — | 5.5 | | ns |
| 16 | Minimum edge-triggered interrupt request deassertion width | | 6.6 | — | 5.5 | | ns |
| 17 | Delay from $\overline{\text{IRQA}}$, $\overline{\text{IRQB}}$, $\overline{\text{IRQC}}$, $\overline{\text{IRQD}}$, $\overline{\text{NMI}}$ assertion to external memory access address out valid | | | | | | |
| | | • Caused by first interrupt instruction fetch | $4.25 \times T_C + 2.0$ | 44.5 | — | 37.4 | ns |
| | • Caused by first interrupt instruction execution | $7.25 \times T_C + 2.0$ | 74.5 | — | 62.4 | ns | |
| 18 | Delay from $\overline{\text{IRQA}}$, $\overline{\text{IRQB}}$, $\overline{\text{IRQC}}$, $\overline{\text{IRQD}}$, $\overline{\text{NMI}}$ assertion to general-purpose transfer output valid caused by first interrupt instruction execution | $10 \times T_C + 5.0$ | 105.0 | — | 88.3 | | ns |

Table 3-7 Reset, Stop, Mode Select, and Interrupt Timing 100 and 120 MHz Values¹ (continued)

| No | Characteristics | Expression ² | 100 MHz | | 120 MHz | | Unit |
|----|---------------------------------------------------------------------------------------------------------------------------------------------------------------------------------------------------------------------------------------------------------------------------------------------------------------------------------------------------------------------------------------------------------------------------------------------------------------|-----------------------------------------------------------|----------|-------------------|---------|--------|------|
| | | | Min | Max | Min | Max | |
| 19 | Delay from address output valid caused by first interrupt instruction execute to interrupt request deassertion for level sensitive fast interrupts ⁶ | $(3.75 + WS) \times T_C - 10.94$ | — | Note ⁷ | — | Note 7 | ns |
| 20 | Delay from \overline{RD} assertion to interrupt request deassertion for level sensitive fast interrupts ⁶ | $(3.25 + WS) \times T_C - 10.94$ | — | Note 7 | — | Note 7 | |
| 21 | Delay from \overline{WR} assertion to interrupt request deassertion for level sensitive fast interrupts ^{6, 8} <ul style="list-style-type: none"> • DRAM for all WS • SRAM WS = 1 • SRAM WS = 2, 3 • SRAM WS ≥ 4 | $(WS + 3.5) \times T_C - 10.94$ | — | Note 7 | — | Note 7 | ns |
| | | $(WS + 3.5) \times T_C - 10.94$ | — | Note 7 | — | Note 7 | ns |
| | | $1.75 \times T_C - 4.0$ | — | Note 7 | — | Note 7 | ns |
| | | $2.75 \times T_C - 4.0$ | — | Note 7 | — | Note 7 | ns |
| 22 | Synchronous interrupt setup time from \overline{IRQA} , \overline{IRQB} , \overline{IRQC} , \overline{IRQD} , NMI assertion to the CLKOUT Transition 2 | $0.6 \times T_C - 0.1$ | 5.9 | | 4.9 | — | ns |
| 23 | Synchronous interrupt delay time from the CLKOUT Transition 2 to the first external address output valid caused by the first instruction fetch after coming out of Wait Processing state <ul style="list-style-type: none"> • Minimum • Maximum | $9.25 \times T_C + 1.0$ | 93.5 | — | 78.1 | — | ns |
| | | $24.75 \times T_C + 5.0$ | — | 252.5 | — | 211.2 | ns |
| 24 | Duration for \overline{IRQA} assertion to recover from Stop state | $0.6 \times T_C - 0.1$ | 5.9 | — | 4.9 | — | ns |
| 25 | Delay from \overline{IRQA} assertion to fetch of first instruction (when exiting Stop) ^{9, 3} <ul style="list-style-type: none"> • PLL is not active during Stop (PCTL Bit 17 = 0) and Stop delay is enabled (OMR Bit 6 = 0) • PLL is not active during Stop (PCTL Bit 17 = 0) and Stop delay is not enabled (OMR Bit 6 = 1) • PLL is active during Stop (PCTL Bit 17 = 1) (Implies No Stop Delay) | $PLC \times ET_C \times PDF + (128K - PLC/2) \times T_C$ | 1.3 | 13.6 | — | — | ms |
| | | $PLC \times ET_C \times PDF + (23.75 \pm 0.5) \times T_C$ | 232.5 ns | 12.3 ms | — | — | |
| | | $(8.25 \pm 0.5) \times T_C$ | 77.5 | 87.5 | 64.6 | 72.9 | ns |
| 26 | Duration of level sensitive \overline{IRQA} assertion to ensure interrupt service (when exiting Stop) ^{9, 3} <ul style="list-style-type: none"> • PLL is not active during Stop (PCTL Bit 17 = 0) and Stop delay is enabled (OMR Bit 6 = 0) • PLL is not active during Stop (PCTL Bit 17 = 0) and Stop delay is not enabled (OMR Bit 6 = 1) • PLL is active during Stop (PCTL Bit 17 = 1) (implies no Stop delay) | $PLC \times ET_C \times PDF + (128K - PLC/2) \times T_C$ | 13.6 | — | | | ms |
| | | $PLC \times ET_C \times PDF + (20.5 \pm 0.5) \times T_C$ | 12.3 | — | | | ms |
| | | $5.5 \times T_C$ | 55.0 | — | 45.8 | — | ns |

Table 3-7 Reset, Stop, Mode Select, and Interrupt Timing 100 and 120 MHz Values¹ (continued)

| No | Characteristics | Expression ² | 100 MHz | | 120 MHz | | Unit |
|----|--------------------------------------------------------------------------------------------------------------------------------------------------------------------------------|-------------------------|---------|-------|---------|-------|------|
| | | | Min | Max | Min | Max | |
| 27 | Interrupt Requests Rate | | | | | | |
| | • HI08, ESAI, SHI, Timer | $12T_C$ | — | 120.0 | — | 100.0 | ns |
| | • DMA | $8T_C$ | — | 80.0 | — | 66.7 | ns |
| | • \overline{IRQ} , \overline{NMI} (edge trigger) | $8T_C$ | — | 80.0 | — | 66.7 | ns |
| | • \overline{IRQ} , \overline{NMI} (level trigger) | $12T_C$ | — | 120.0 | — | 100.0 | ns |
| 28 | DMA Requests Rate | | | | | | |
| | • Data read from HI08, ESAI, SHI | $6T_C$ | — | 60.0 | — | 50.0 | ns |
| | • Data write to HI08, ESAI, SHI | $7T_C$ | — | 70.0 | — | 58.0 | ns |
| | • Timer | $2T_C$ | — | 20.0 | — | 16.7 | ns |
| | • \overline{IRQ} , \overline{NMI} (edge trigger) | $3T_C$ | — | 30.0 | — | 25.0 | ns |
| 29 | Delay from \overline{IRQA} , \overline{IRQB} , \overline{IRQC} , \overline{IRQD} , \overline{NMI} assertion to external memory (DMA source) access address out valid | $4.25 \times T_C + 2.0$ | 44.0 | — | 37.4 | — | ns |

¹ $V_{CC} = 3.3 \text{ V} \pm 0.16 \text{ V}$; $T_J = 0^\circ\text{C}$ to $+100^\circ\text{C}$, $C_L = 50 \text{ pF}$

² Use expression to compute maximum value.

³ Periodically sampled and not 100% tested.

⁴ For an external clock generator, \overline{RESET} duration is measured during the time in which \overline{RESET} is asserted, V_{CC} is valid, and the EXTAL input is active and valid. For internal oscillator, \overline{RESET} duration is measured during the time in which \overline{RESET} is asserted and V_{CC} is valid. The specified timing reflects the crystal oscillator stabilization time after power-up. This number is affected both by the specifications of the crystal and other components connected to the oscillator and reflects worst case conditions. When the V_{CC} is valid, but the other “required \overline{RESET} duration” conditions (as specified above) have not been yet met, the device circuitry will be in an uninitialized state that can result in significant power consumption and heat-up. Designs should minimize this state to the shortest possible duration.

⁵ If PLL does not lose lock.

⁶ When using fast interrupts and \overline{IRQA} , \overline{IRQB} , \overline{IRQC} , and \overline{IRQD} are defined as level-sensitive, timings 19 through 21 apply to prevent multiple interrupt service. To avoid these timing restrictions, the deasserted Edge-triggered mode is recommended when using fast interrupts. Long interrupts are recommended when using Level-sensitive mode.

⁷ These values depend on the number of wait states (WS) selected.

⁸ WS = number of wait states (measured in clock cycles, number of T_C).

⁹ This timing depends on several settings: For PLL disable, using internal oscillator (PLL Control Register (PCTL) Bit 16 = 0) and oscillator disabled during Stop (PCTL Bit 17 = 0), a stabilization delay is required to assure the oscillator is stable before executing programs. In that case, resetting the Stop delay (OMR Bit 6 = 0) will provide the proper delay. While it is possible to set OMR Bit 6 = 1, it is not recommended and these specifications do not guarantee timings for that case.

For PLL disable, using internal oscillator (PCTL Bit 16 = 0) and oscillator enabled during Stop (PCTL Bit 17=1), no stabilization delay is required and recovery time will be minimal (OMR Bit 6 setting is ignored).

For PLL disable, using external clock (PCTL Bit 16 = 1), no stabilization delay is required and recovery time will be defined by the PCTL Bit 17 and OMR Bit 6 settings.

For PLL enable, if PCTL Bit 17 is 0, the PLL is shutdown during Stop. Recovering from Stop requires the PLL to get locked. The PLL lock procedure duration, PLL Lock Cycles (PLC), may be in the range of 0 to 1000 cycles. This procedure occurs in parallel with the stop delay counter, and stop recovery will end when the last of these two events occurs. The stop delay counter completes count or PLL lock procedure completion. PLC value for PLL disable is 0.

The maximum value for ET_C is 4096 (maximum MF) divided by the desired internal frequency (i.e., for 100 MHz it is $4096/100 \text{ MHz} = 40.96\mu\text{s}$). During the stabilization period, T_C , T_H , and T_L will not be constant, and their width may vary, so timing may vary as well.

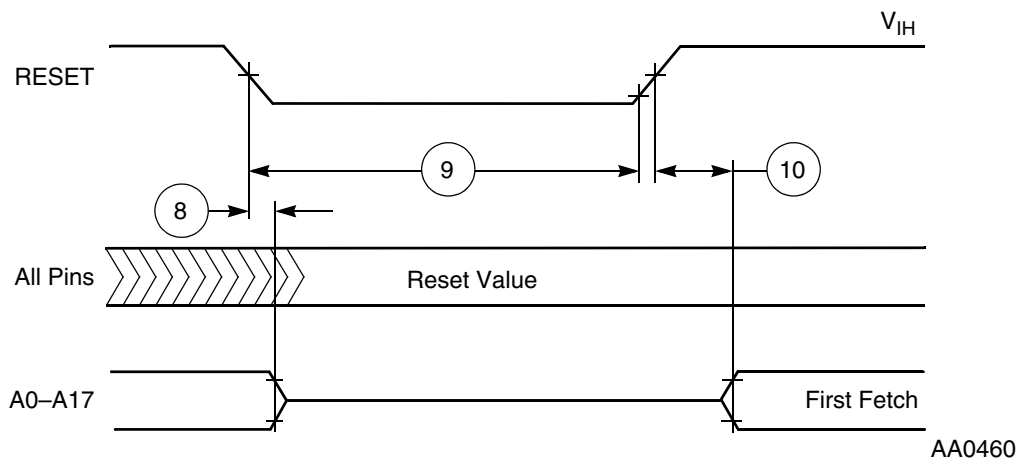

Figure 3-2 Reset Timing

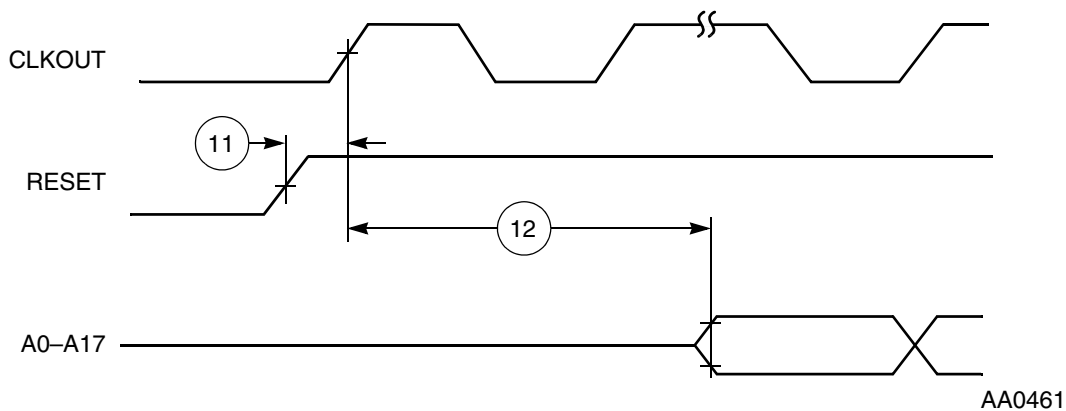
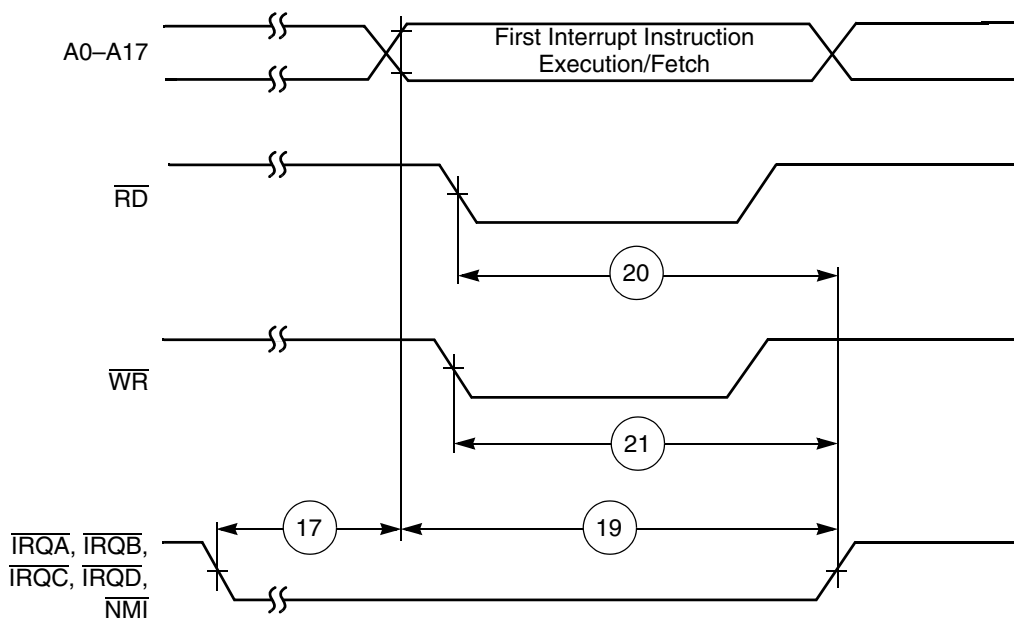
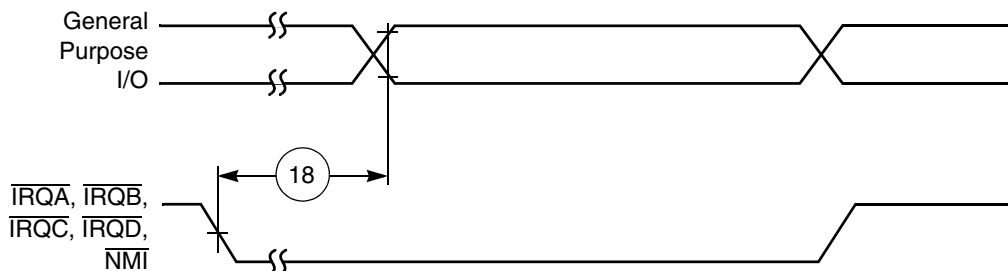

Figure 3-3 Synchronous Reset Timing



a) First Interrupt Instruction Execution



b) General Purpose I/O

AA0462

Figure 3-4 External Fast Interrupt Timing

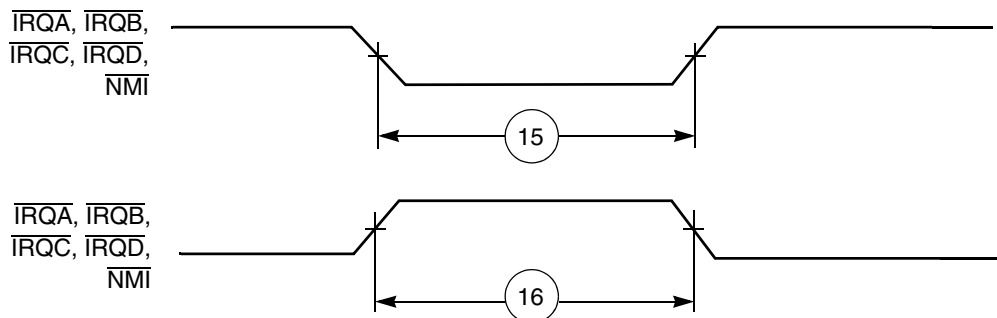

AA0463

Figure 3-5 External Interrupt Timing (Negative Edge-Triggered)

Reset, Stop, Mode Select, and Interrupt Timing

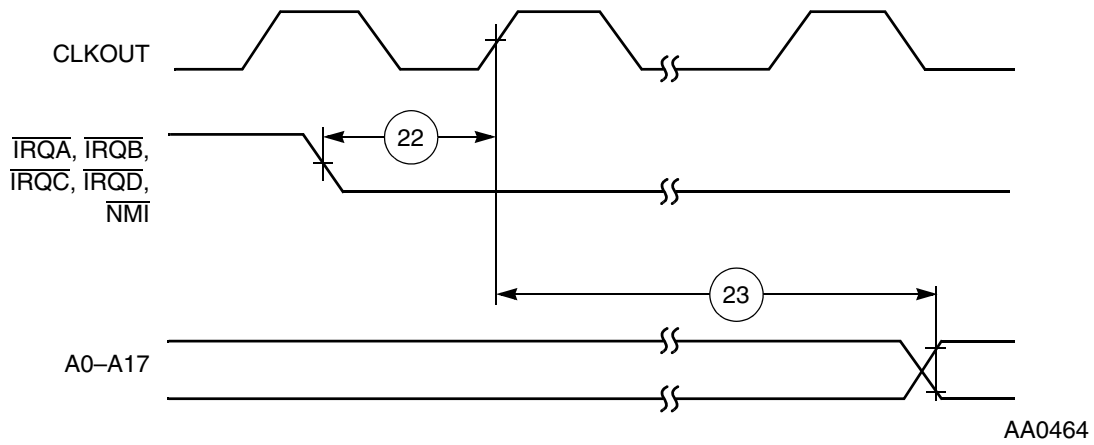

Figure 3-6 Synchronous Interrupt from Wait State Timing

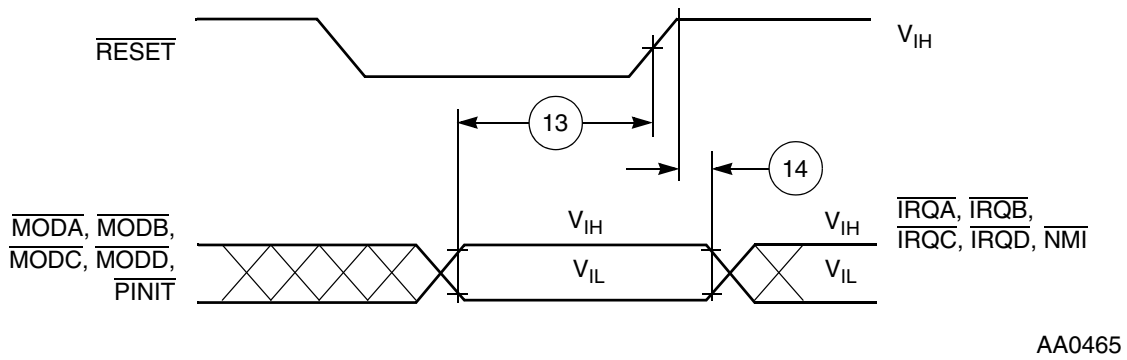

Figure 3-7 Operating Mode Select Timing

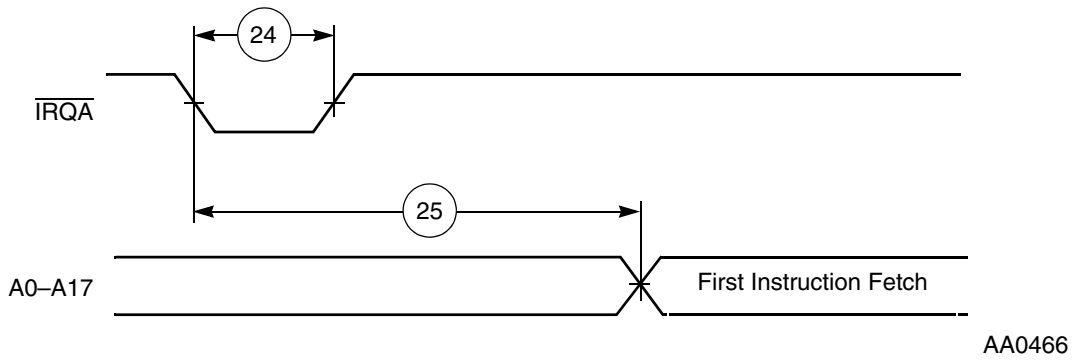

Figure 3-8 Recovery from Stop State Using $\overline{\text{IRQA}}$

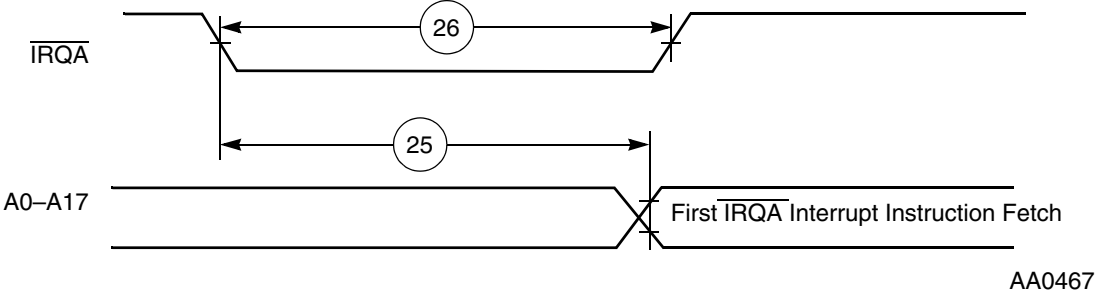

Figure 3-9 Recovery from Stop State Using $\overline{\text{IRQA}}$ Interrupt Service

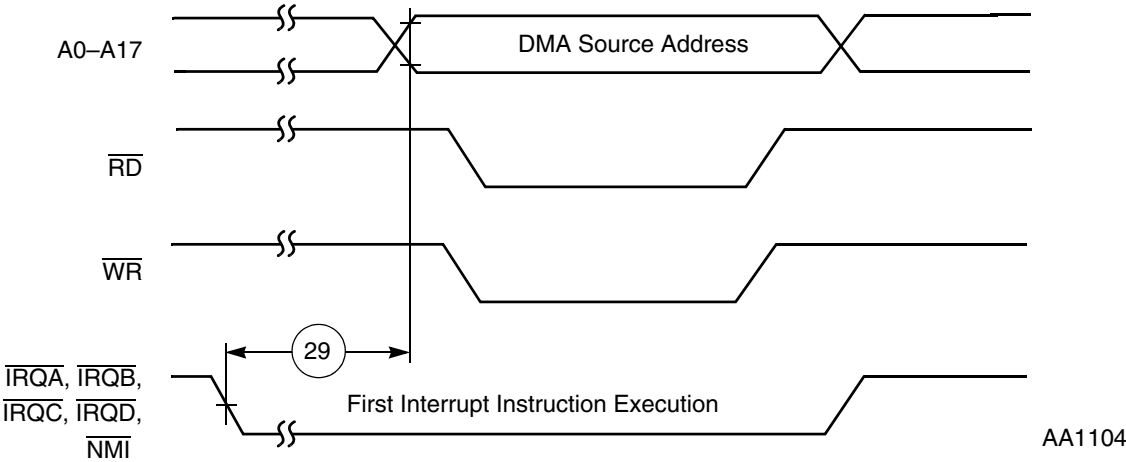

Figure 3-10 External Memory Access (DMA Source) Timing

3.10 External Memory Expansion Port (Port A)

3.10.1 SRAM Timing

Table 3-8 SRAM Read and Write Accesses 100 and 120 MHz¹

| No. | Characteristics | Symbol | Expression ² | 100 MHz | | 120 MHz | | Unit |
|-----|---------------------------------------------------------|------------------|--------------------------------------------------------------------|---------|-----|---------|-----|------|
| | | | | Min | Max | Min | Max | |
| 100 | Address valid and AA assertion pulse width ³ | t_{RC}, t_{WC} | $(WS + 1) \times T_C - 4.0$ [1 ≤ WS ≤ 3] | 16.0 | — | 12.0 | — | ns |
| | | | $(WS + 2) \times T_C - 4.0$ [4 ≤ WS ≤ 7] | 56.0 | — | 46.0 | — | ns |
| | | | $(WS + 3) \times T_C - 4.0$ [WS ≥ 8] | 106.0 | — | 87.0 | — | ns |
| 101 | Address and AA valid to \overline{WR} assertion | t_{AS} | 100 MHz: $0.25 \times T_C - 2.0$ [WS = 1] | 0.5 | — | 0.1 | — | ns |
| | | | $1.25 \times T_C - 2.0$ [WS ≥ 4] | 10.5 | — | 8.4 | — | ns |
| 102 | \overline{WR} assertion pulse width | t_{WP} | 100 MHz: $1.5 \times T_C - 4.0$ [WS = 1] | 11.0 | — | 8.5 | — | ns |
| | | | All frequencies: $WS \times T_C - 4.0$ [2 ≤ WS ≤ 3] | 16.0 | — | 12.7 | — | ns |
| | | | $(WS - 0.5) \times T_C - 4.0$ [WS ≥ 4] | 31.0 | --- | 25.2 | — | |
| 103 | \overline{WR} deassertion to address not valid | t_{WR} | 100 MHz: $0.25 \times T_C - 2.0$ [1 ≤ WS ≤ 3] | 0.5 | — | 0.1 | — | ns |
| | | | $1.25 \times T_C - 2.0$ [4 ≤ WS ≤ 7] | 10.5 | — | 8.4 | — | |
| | | | $2.25 \times T_C - 2.0$ [WS ≥ 8] | 20.5 | — | 16.7 | — | |
| | | | All frequencies: $1.25 \times T_C - 4.0$ [4 ≤ WS ≤ 7] | 8.5 | — | 6.4 | — | |
| | | | $2.25 \times T_C - 4.0$ [WS ≥ 8] | 18.5 | — | 14.7 | — | |

Table 3-8 SRAM Read and Write Accesses 100 and 120 MHz¹ (continued)

| No. | Characteristics | Symbol | Expression ² | 100 MHz | | 120 MHz | | Unit |
|-----|-----------------------------------------------------------------|-------------------|---------------------------------------------------------------|---------|------|---------|------|------|
| | | | | Min | Max | Min | Max | |
| 104 | Address and AA valid to input data valid | t_{AA}, t_{AC} | 100 MHz: $(WS + 0.75) \times T_C - 7.0$ [WS ≥ 1] | — | 10.5 | | 7.6 | ns |
| 105 | \overline{RD} assertion to input data valid | t_{OE} | 100 MHz: $(WS + 0.25) \times T_C - 7.0$ [WS ≥ 1] | — | 5.5 | — | 3.4 | ns |
| 106 | \overline{RD} deassertion to data not valid (data hold time) | t_{OHZ} | | 0.0 | — | 0.0 | — | ns |
| 107 | Address valid to \overline{WR} deassertion ³ | t_{AW} | $(WS + 0.75) \times T_C - 4.0$ [WS ≥ 1] | 13.5 | — | 10.6 | — | ns |
| 108 | Data valid to \overline{WR} deassertion (data setup time) | $t_{DS} (t_{DW})$ | 100 MHz: $(WS - 0.25) \times T_C - 3.0$ [WS ≥ 1] | 4.5 | — | 3.2 | — | ns |
| 109 | Data hold time from \overline{WR} deassertion | t_{DH} | 100 MHz: $0.25 \times T_C - 2.0$ [1 ≤ WS ≤ 3] | 0.5 | — | 0.1 | — | ns |
| | | | $1.25 \times T_C - 2.0$ [4 ≤ WS ≤ 7] | 10.5 | — | 8.4 | — | |
| | | | $2.25 \times T_C - 2.0$ [WS ≥ 8] | 20.5 | — | 16.7 | — | |
| 110 | \overline{WR} assertion to data active ⁴ | | $0.75 \times T_C - 3.7$ [WS = 1] | — | — | 2.5 | — | ns |
| | | | $0.25 \times T_C - 3.7$ [2 ≤ WS ≤ 3] | — | — | 0.0 | — | |
| | | | $-0.25 \times T_C - 3.7$ [WS ≥ 4] | — | — | 0.0 | — | |
| 111 | \overline{WR} deassertion to data high impedance ⁴ | | $0.25 \times T_C + 0.2$ [1 ≤ WS ≤ 3] | — | — | — | 2.3 | ns |
| | | | $1.25 \times T_C + 0.2$ [4 ≤ WS ≤ 7] | — | — | — | 10.6 | |
| | | | $2.25 \times T_C + 0.2$ [WS ≥ 8] | — | — | — | 18.9 | |

Table 3-8 SRAM Read and Write Accesses 100 and 120 MHz¹ (continued)

| No. | Characteristics | Symbol | Expression ² | 100 MHz | | 120 MHz | | Unit |
|-----|--------------------------------------------------------------------------|--------|------------------------------------------------------------|---------|-----|---------|-----|------|
| | | | | Min | Max | Min | Max | |
| 112 | Previous \overline{RD} deassertion to data active (write) ⁴ | | $1.25 \times T_C - 4.0$ [1 ≤ WS ≤ 3] | — | — | 6.4 | — | ns |
| | | | $2.25 \times T_C - 4.0$ [4 ≤ WS ≤ 7] | — | — | 14.7 | — | |
| | | | $3.25 \times T_C - 4.0$ [WS ≥ 8] | — | — | 23.1 | — | |
| 113 | \overline{RD} deassertion time | | 100 MHz: $0.75 \times T_C - 4.0$ [1 ≤ WS ≤ 3] | 3.5 | — | 2.2 | — | ns |
| | | | $1.75 \times T_C - 4.0$ [4 ≤ WS ≤ 7] | 13.5 | — | 10.6 | — | |
| | | | $2.75 \times T_C - 4.0$ [WS ≥ 8] | 23.5 | — | 18.9 | — | |
| 114 | \overline{WR} deassertion time | | 100 MHz: $0.5 \times T_C - 4.0$ [WS = 1] | 1.0 | — | 0.2 | — | ns |
| | | | $T_C - 2.0$ [2 ≤ WS ≤ 3] | 6.0 | — | 6.3 | — | |
| | | | $2.5 \times T_C - 4.0$ [4 ≤ WS ≤ 7] | 21.0 | — | 16.8 | — | |
| | | | $3.5 \times T_C - 4.0$ [WS ≥ 8] | 31.0 | — | 25.2 | — | |
| 115 | Address valid to \overline{RD} assertion | | 100 MHz: $0.5 \times T_C - 4.0$ | 1.0 | — | 0.2 | — | ns |
| 116 | \overline{RD} assertion pulse width | | 100 MHz: $(WS + 0.25) \times T_C - 4.0$ | 8.5 | — | 6.4 | — | ns |
| 117 | \overline{RD} deassertion to address not valid | | 100 MHz: $0.25 \times T_C - 2.0$ [1 ≤ WS ≤ 3] | 0.5 | — | 0.1 | — | ns |
| | | | $1.25 \times T_C - 2.0$ [4 ≤ WS ≤ 7] | 10.5 | — | 8.4 | — | |
| | | | $2.25 \times T_C - 2.0$ [WS ≥ 8] | 20.5 | — | 16.7 | — | |

Table 3-8 SRAM Read and Write Accesses 100 and 120 MHz¹ (continued)

| No. | Characteristics | Symbol | Expression ² | 100 MHz | | 120 MHz | | Unit |
|-----|------------------------------------------------------------------------------------------|--------|-------------------------|---------|-----|---------|-----|------|
| | | | | Min | Max | Min | Max | |
| 118 | \overline{TA} setup before \overline{RD} or \overline{WR} deassertion ⁵ | | $0.25 \times T_C + 2.0$ | 4.5 | — | 4.1 | — | ns |
| 119 | \overline{TA} hold after \overline{RD} or \overline{WR} deassertion | | | 0 | — | 0.0 | — | ns |

¹ All timings for 100 MHz are measured from 0.5 Vcc to .05 Vcc

² WS is the number of wait states specified in the BCR.

³ Timings 100, 107 are guaranteed by design, not tested.

⁴ Timing 110, 111, and 112, are not specified for 100 MHz.

⁵ In the case of \overline{TA} negation: timing 118 is relative to the deassertion edge of \overline{RD} or \overline{WR} were \overline{TA} to remain active.

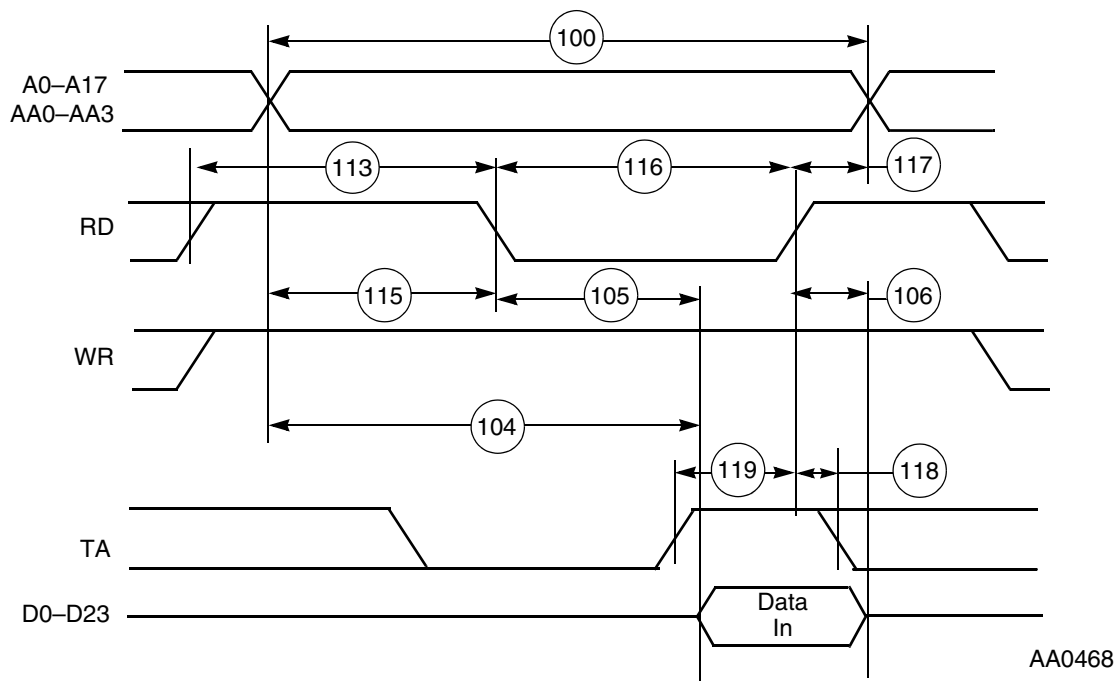

Figure 3-11 SRAM Read Access

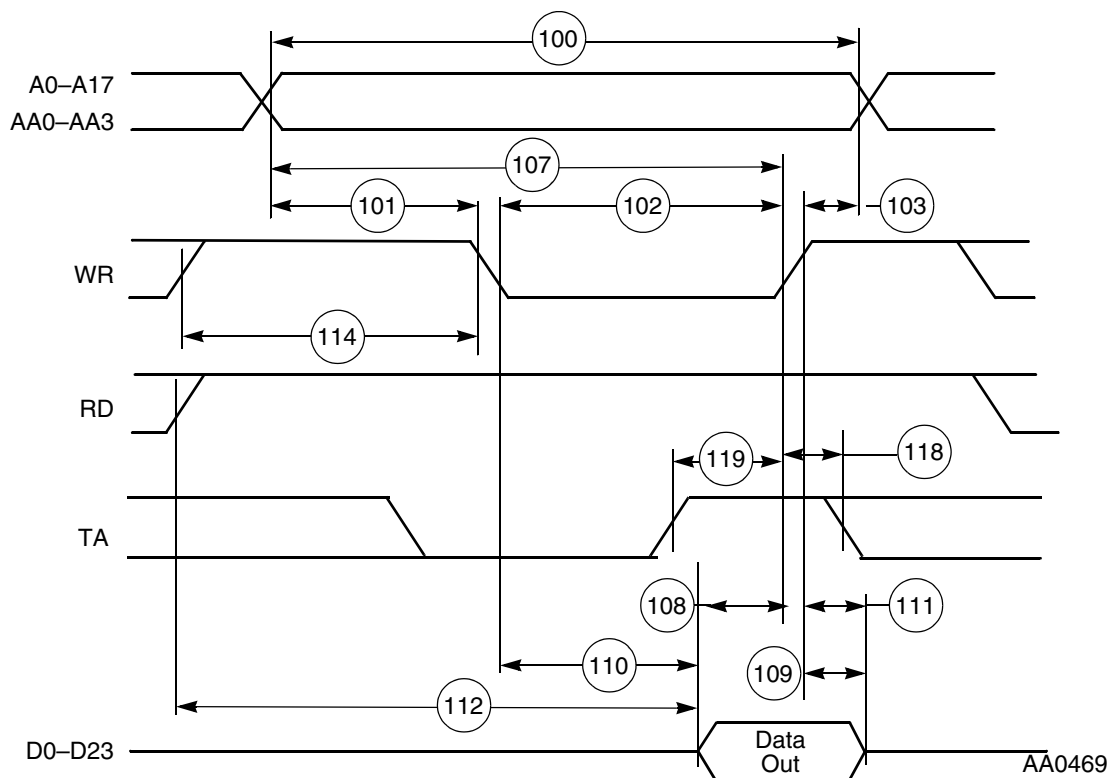
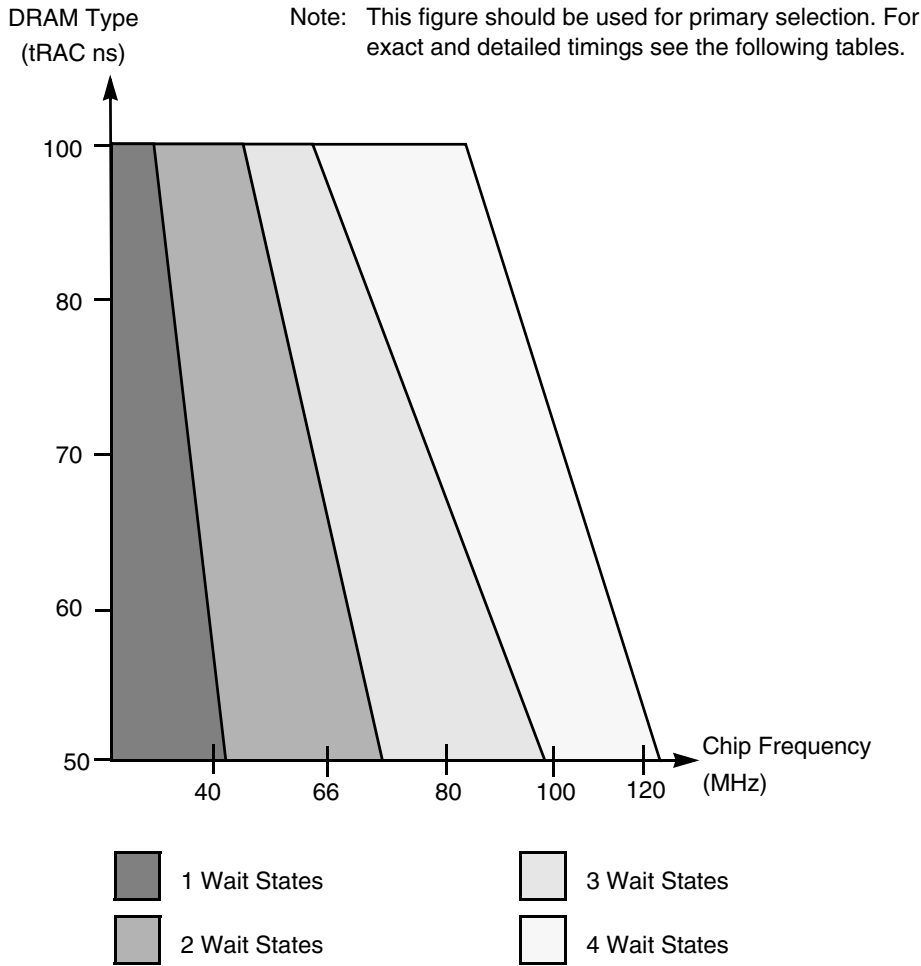

Figure 3-12 SRAM Write Access

3.10.2 DRAM Timing

The selection guides provided in [Figure 3-13](#) and [Figure 3-16](#) should be used for primary selection only. Final selection should be based on the timing provided in the following tables. As an example, the selection guide suggests that 4 wait states must be used for 100 MHz operation when using Page Mode DRAM. However, by using the information in the appropriate table, a designer may choose to evaluate whether fewer wait states might be used by determining which timing prevents operation at 100 MHz, running the chip at a slightly lower frequency (e.g., 95 MHz), using faster DRAM (if it becomes available), and control factors such as capacitive and resistive load to improve overall system performance.



AA0472

Figure 3-13 DRAM Page Mode Wait States Selection Guide

Table 3-9 DRAM Page Mode Timings, One Wait State (Low-Power Applications)^{1, 2, 3}

| No. | Characteristics | Symbol | Expression | 20 MHz ⁴ | | 30 MHz ⁴ | | Unit |
|-----|-------------------------------------------------------------------------|------------|-------------------------|---------------------|------|---------------------|------|------|
| | | | | Min | Max | Min | Max | |
| 131 | Page mode cycle time for two consecutive accesses of the same direction | t_{PC} | $2 \times T_C$ | 100.0 | — | 66.7 | — | ns |
| | Page mode cycle time for mixed (read and write) accesses. | | $1.25 \times T_C$ | 62.5 | — | 41.7 | — | |
| 132 | \overline{CAS} assertion to data valid (read) | t_{CAC} | $T_C - 7.5$ | — | 42.5 | — | 25.8 | ns |
| 133 | Column address valid to data valid (read) | t_{AA} | $1.5 \times T_C - 7.5$ | — | 67.5 | — | 42.5 | ns |
| 134 | \overline{CAS} deassertion to data not valid (read hold time) | t_{OFF} | | 0.0 | — | 0.0 | — | ns |
| 135 | Last \overline{CAS} assertion to \overline{RAS} deassertion | t_{RSH} | $0.75 \times T_C - 4.0$ | 33.5 | — | 21.0 | — | ns |
| 136 | Previous \overline{CAS} deassertion to \overline{RAS} deassertion | t_{RHCP} | $2 \times T_C - 4.0$ | 96.0 | — | 62.7 | — | ns |

Table 3-9 DRAM Page Mode Timings, One Wait State (Low-Power Applications)^{1, 2, 3} (continued)

| No. | Characteristics | Symbol | Expression | 20 MHz ⁴ | | 30 MHz ⁴ | | Unit |
|-----|----------------------------------------------------------------------------------------------------------------------------------------------------------------------------------------------------------------------------------------------|------------------|----------------------------------------------------------------------------------------------------------|---------------------------------|------------------|---------------------------------|------------------|------|
| | | | | Min | Max | Min | Max | |
| 137 | $\overline{\text{CAS}}$ assertion pulse width | t_{CAS} | $0.75 \times T_C - 4.0$ | 33.5 | — | 21.0 | — | ns |
| 138 | Last $\overline{\text{CAS}}$ deassertion to $\overline{\text{RAS}}$ deassertion ⁵ <ul style="list-style-type: none"> • BRW[1:0] = 00 • BRW[1:0] = 01 • BRW[1:0] = 10 • BRW[1:0] = 11 | t_{CRP} | $1.75 \times T_C - 6.0$ $3.25 \times T_C - 6.0$ $4.25 \times T_C - 6.0$ $6.25 \times T_C - 6.0$ | 81.5 156.5 206.5 306.5 | — — — — | 52.3 102.2 135.5 202.1 | — — — — | ns |
| 139 | $\overline{\text{CAS}}$ deassertion pulse width | t_{CP} | $0.5 \times T_C - 4.0$ | 21.0 | — | 12.7 | — | ns |
| 140 | Column address valid to $\overline{\text{CAS}}$ assertion | t_{ASC} | $0.5 \times T_C - 4.0$ | 21.0 | — | 12.7 | — | ns |
| 141 | $\overline{\text{CAS}}$ assertion to column address not valid | t_{CAH} | $0.75 \times T_C - 4.0$ | 33.5 | — | 21.0 | — | ns |
| 142 | Last column address valid to $\overline{\text{RAS}}$ deassertion | t_{RAL} | $2 \times T_C - 4.0$ | 96.0 | — | 62.7 | — | ns |
| 143 | $\overline{\text{WR}}$ deassertion to $\overline{\text{CAS}}$ assertion | t_{RCS} | $0.75 \times T_C - 3.8$ | 33.7 | — | 21.2 | — | ns |
| 144 | $\overline{\text{CAS}}$ deassertion to $\overline{\text{WR}}$ assertion | t_{RCH} | $0.25 \times T_C - 3.7$ | 8.8 | — | 4.6 | — | ns |
| 145 | $\overline{\text{CAS}}$ assertion to $\overline{\text{WR}}$ deassertion | t_{WCH} | $0.5 \times T_C - 4.2$ | 20.8 | — | 12.5 | — | ns |
| 146 | $\overline{\text{WR}}$ assertion pulse width | t_{WP} | $1.5 \times T_C - 4.5$ | 70.5 | — | 45.5 | — | ns |
| 147 | Last $\overline{\text{WR}}$ assertion to $\overline{\text{RAS}}$ deassertion | t_{RWL} | $1.75 \times T_C - 4.3$ | 83.2 | — | 54.0 | — | ns |
| 148 | $\overline{\text{WR}}$ assertion to $\overline{\text{CAS}}$ deassertion | t_{CWL} | $1.75 \times T_C - 4.3$ | 83.2 | — | 54.0 | — | ns |
| 149 | Data valid to $\overline{\text{CAS}}$ assertion (Write) | t_{DS} | $0.25 \times T_C - 4.0$ | 8.5 | — | 4.3 | — | ns |
| 150 | $\overline{\text{CAS}}$ assertion to data not valid (write) | t_{DH} | $0.75 \times T_C - 4.0$ | 33.5 | — | 21.0 | — | ns |
| 151 | $\overline{\text{WR}}$ assertion to $\overline{\text{CAS}}$ assertion | t_{WCS} | $T_C - 4.3$ | 45.7 | — | 29.0 | — | ns |
| 152 | Last $\overline{\text{RD}}$ assertion to $\overline{\text{RAS}}$ deassertion | t_{ROH} | $1.5 \times T_C - 4.0$ | 71.0 | — | 46.0 | — | ns |
| 153 | $\overline{\text{RD}}$ assertion to data valid | t_{GA} | $T_C - 7.5$ | — | 42.5 | — | 25.8 | ns |
| 154 | $\overline{\text{RD}}$ deassertion to data not valid ⁶ | t_{GZ} | | 0.0 | — | 0.0 | — | ns |
| 155 | $\overline{\text{WR}}$ assertion to data active | | $0.75 \times T_C - 0.3$ | 37.2 | — | 24.7 | — | ns |
| 156 | $\overline{\text{WR}}$ deassertion to data high impedance | | $0.25 \times T_C$ | — | 12.5 | — | 8.3 | ns |

¹ The number of wait states for Page mode access is specified in the DCR.

² The refresh period is specified in the DCR.

³ All the timings are calculated for the worst case. Some of the timings are better for specific cases (e.g., t_{PC} equals $2 \times T_C$ for read-after-read or write-after-write sequences).

⁴ Reduced DSP clock speed allows use of Page Mode DRAM with one Wait state. See [Figure 3-13](#).

⁵ BRW[1:0] (DRAM control register bits) defines the number of wait states that should be inserted in each DRAM out-of-page access.

⁶ $\overline{\text{RD}}$ deassertion will always occur after $\overline{\text{CAS}}$ deassertion; therefore, the restricted timing is t_{OFF} and not t_{GZ} .

Table 3-10 DRAM Page Mode Timings, Two Wait States^{1, 2, 3, 4}

| No. | Characteristics | Symbol | Expression | 80 MHz | | Unit |
|-----|--------------------------------------------------------------------------------------------------------------------------------------------------------------------------------------------------------------------------------|------------|-------------------------|--------|------|------|
| | | | | Min | Max | |
| 131 | Page mode cycle time for two consecutive accesses of the same direction ⁵ | t_{PC} | $3 \times T_C$ | 37.5 | — | ns |
| | Page mode cycle time for mixed (read and write) accesses. ⁵ | | $2.75 \times T_C$ | 34.4 | — | |
| 132 | \overline{CAS} assertion to data valid (read) | t_{CAC} | $1.5 \times T_C - 6.5$ | — | 12.3 | ns |
| 133 | Column address valid to data valid (read) | t_{AA} | $2.5 \times T_C - 6.5$ | — | 24.8 | ns |
| 134 | \overline{CAS} deassertion to data not valid (read hold time) | t_{OFF} | | 0.0 | — | ns |
| 135 | Last \overline{CAS} assertion to \overline{RAS} deassertion | t_{RSH} | $1.75 \times T_C - 4.0$ | 17.9 | — | ns |
| 136 | Previous \overline{CAS} deassertion to \overline{RAS} deassertion | t_{RHCP} | $3.25 \times T_C - 4.0$ | 36.6 | — | ns |
| 137 | \overline{CAS} assertion pulse width | t_{CAS} | $1.5 \times T_C - 4.0$ | 14.8 | — | ns |
| 138 | Last \overline{CAS} deassertion to \overline{RAS} deassertion ⁶ <ul style="list-style-type: none"> • BRW[1:0] = 00 • BRW[1:0] = 01 • BRW[1:0] = 10 • BRW[1:0] = 11 | t_{CRP} | $2.0 \times T_C - 6.0$ | 19.0 | — | ns |
| | | | $3.5 \times T_C - 6.0$ | 37.8 | — | |
| | | | $4.5 \times T_C - 6.0$ | 50.3 | — | |
| | | | $6.5 \times T_C - 6.0$ | 75.3 | — | |
| 139 | \overline{CAS} deassertion pulse width | t_{CP} | $1.25 \times T_C - 4.0$ | 11.6 | — | ns |
| 140 | Column address valid to \overline{CAS} assertion | t_{ASC} | $T_C - 4.0$ | 8.5 | — | ns |
| 141 | \overline{CAS} assertion to column address not valid | t_{CAH} | $1.75 \times T_C - 4.0$ | 17.9 | — | ns |
| 142 | Last column address valid to \overline{RAS} deassertion | t_{RAL} | $3 \times T_C - 4.0$ | 33.5 | — | ns |
| 143 | \overline{WR} deassertion to \overline{CAS} assertion | t_{RCS} | $1.25 \times T_C - 3.8$ | 11.8 | — | ns |
| 144 | \overline{CAS} deassertion to \overline{WR} assertion | t_{RCH} | $0.5 \times T_C - 3.7$ | 2.6 | — | ns |
| 145 | \overline{CAS} assertion to \overline{WR} deassertion | t_{WCH} | $1.5 \times T_C - 4.2$ | 14.6 | — | ns |
| 146 | \overline{WR} assertion pulse width | t_{WP} | $2.5 \times T_C - 4.5$ | 26.8 | — | ns |
| 147 | Last \overline{WR} assertion to \overline{RAS} deassertion | t_{RWL} | $2.75 \times T_C - 4.3$ | 30.1 | — | ns |
| 148 | \overline{WR} assertion to \overline{CAS} deassertion | t_{CWL} | $2.5 \times T_C - 4.3$ | 27.0 | — | ns |
| 149 | Data valid to \overline{CAS} assertion (write) | t_{DS} | $0.25 \times T_C - 3.0$ | 0.1 | — | ns |
| 150 | \overline{CAS} assertion to data not valid (write) | t_{DH} | $1.75 \times T_C - 4.0$ | 17.9 | — | ns |
| 151 | \overline{WR} assertion to \overline{CAS} assertion | t_{WCS} | $T_C - 4.3$ | 8.2 | — | ns |
| 152 | Last \overline{RD} assertion to \overline{RAS} deassertion | t_{ROH} | $2.5 \times T_C - 4.0$ | 27.3 | — | ns |

Table 3-10 DRAM Page Mode Timings, Two Wait States^{1, 2, 3, 4} (continued)

| No. | Characteristics | Symbol | Expression | 80 MHz | | Unit |
|-----|------------------------------------------------------------|----------|-------------------------|--------|------|------|
| | | | | Min | Max | |
| 153 | \overline{RD} assertion to data valid | t_{GA} | $1.75 \times T_C - 6.5$ | — | 15.4 | ns |
| 154 | \overline{RD} deassertion to data not valid ⁷ | t_{GZ} | | 0.0 | — | ns |
| 155 | \overline{WR} assertion to data active | | $0.75 \times T_C - 0.3$ | 9.1 | — | ns |
| 156 | \overline{WR} deassertion to data high impedance | | $0.25 \times T_C$ | — | 3.1 | ns |

- ¹ The number of wait states for Page mode access is specified in the DCR.
- ² The refresh period is specified in the DCR.
- ³ The asynchronous delays specified in the expressions are valid for DSP56362.
- ⁴ All the timings are calculated for the worst case. Some of the timings are better for specific cases (e.g., t_{PC} equals $3 \times T_C$ for read-after-read or write-after-write sequences).
- ⁵ There are not any fast enough DRAMs to fit to two wait states Page mode @ 100MHz. See [Figure 3-13](#).
- ⁶ BRW[1:0] (DRAM Control Register bits) defines the number of wait states that should be inserted in each DRAM out-of-page access.
- ⁷ \overline{RD} deassertion will always occur after \overline{CAS} deassertion; therefore, the restricted timing is t_{OFF} and not t_{GZ} .

Table 3-11 DRAM Page Mode Timings, Three Wait States^{1, 2, 3, 4}

| No. | Characteristics | Symbol | Expression | 100 MHz | | Unit |
|-----|------------------------------------------------------------------------------------------------------------------------------------------------------------------------------------------------------------------------------|------------|-----------------------------------------|---------|------|------|
| | | | | Min | Max | |
| 131 | Page mode cycle time for two consecutive accesses of the same direction | t_{PC} | $4 \times T_C$ | 40.0 | — | ns |
| | Page mode cycle time for mixed (read and write) accesses. | | $3.5 \times T_C$ | 35.0 | — | |
| 132 | \overline{CAS} assertion to data valid (read) | t_{CAC} | 100 MHz: $2 \times T_C - 7.0$ | — | 13.0 | ns |
| 133 | Column address valid to data valid (read) | t_{AA} | 100 MHz: $3 \times T_C - 7.0$ | — | 23.0 | ns |
| 134 | \overline{CAS} deassertion to data not valid (read hold time) | t_{OFF} | | 0.0 | — | ns |
| 135 | Last \overline{CAS} assertion to \overline{RAS} deassertion | t_{RSH} | $2.5 \times T_C - 4.0$ | 21.0 | — | ns |
| 136 | Previous \overline{CAS} deassertion to \overline{RAS} deassertion | t_{RHCP} | $4.5 \times T_C - 4.0$ | 41.0 | — | ns |
| 137 | \overline{CAS} assertion pulse width | t_{CAS} | $2 \times T_C - 4.0$ | 16.0 | — | ns |
| 138 | Last \overline{CAS} deassertion to \overline{RAS} assertion ⁵ <ul style="list-style-type: none"> • BRW[1:0] = 00 • BRW[1:0] = 01 • BRW[1:0] = 10 • BRW[1:0] = 11 | t_{CRP} | $2.25 \times T_C - 6.0$ | — | — | ns |
| | | | $3.75 \times T_C - 6.0$ | — | — | |
| | | | $4.75 \times T_C - 6.0$ | 41.5 | — | |
| | | | $6.75 \times T_C - 6.0$ | 61.5 | — | |
| | | | | | | |

Table 3-11 DRAM Page Mode Timings, Three Wait States^{1, 2, 3, 4} (continued)

| No. | Characteristics | Symbol | Expression | 100 MHz | | Unit |
|-----|------------------------------------------------------------------------------|------------------|-----------------------------------------------------|---------|------|------|
| | | | | Min | Max | |
| 139 | $\overline{\text{CAS}}$ deassertion pulse width | t_{CP} | $1.5 \times T_{\text{C}} - 4.0$ | 11.0 | — | ns |
| 140 | Column address valid to $\overline{\text{CAS}}$ assertion | t_{ASC} | $T_{\text{C}} - 4.0$ | 6.0 | — | ns |
| 141 | $\overline{\text{CAS}}$ assertion to column address not valid | t_{CAH} | $2.5 \times T_{\text{C}} - 4.0$ | 21.0 | — | ns |
| 142 | Last column address valid to $\overline{\text{RAS}}$ deassertion | t_{RAL} | $4 \times T_{\text{C}} - 4.0$ | 36.0 | — | ns |
| 143 | $\overline{\text{WR}}$ deassertion to $\overline{\text{CAS}}$ assertion | t_{RCS} | 100 MHz: $1.25 \times T_{\text{C}} - 4.0$ | 8.5 | | ns |
| 144 | $\overline{\text{CAS}}$ deassertion to $\overline{\text{WR}}$ assertion | t_{RCH} | 100 MHz: $0.75 \times T_{\text{C}} - 4.0$ | 3.5 | | ns |
| 145 | $\overline{\text{CAS}}$ assertion to $\overline{\text{WR}}$ deassertion | t_{WCH} | $2.25 \times T_{\text{C}} - 4.2$ | 18.3 | — | ns |
| 146 | $\overline{\text{WR}}$ assertion pulse width | t_{WP} | $3.5 \times T_{\text{C}} - 4.5$ | 30.5 | — | ns |
| 147 | Last $\overline{\text{WR}}$ assertion to $\overline{\text{RAS}}$ deassertion | t_{RWL} | $3.75 \times T_{\text{C}} - 4.3$ | 33.2 | — | ns |
| 148 | $\overline{\text{WR}}$ assertion to $\overline{\text{CAS}}$ deassertion | t_{CWL} | $3.25 \times T_{\text{C}} - 4.3$ | 28.2 | — | ns |
| 149 | Data valid to $\overline{\text{CAS}}$ assertion (write) | t_{DS} | $0.5 \times T_{\text{C}} - 4.0$ | 1.0 | — | ns |
| 150 | $\overline{\text{CAS}}$ assertion to data not valid (write) | t_{DH} | $2.5 \times T_{\text{C}} - 4.0$ | 21.0 | — | ns |
| 151 | $\overline{\text{WR}}$ assertion to $\overline{\text{CAS}}$ assertion | t_{WCS} | $1.25 \times T_{\text{C}} - 4.3$ | 8.2 | — | ns |
| 152 | Last $\overline{\text{RD}}$ assertion to $\overline{\text{RAS}}$ deassertion | t_{ROH} | $3.5 \times T_{\text{C}} - 4.0$ | 31.0 | — | ns |
| 153 | $\overline{\text{RD}}$ assertion to data valid | t_{GA} | 100 MHz: $2.5 \times T_{\text{C}} - 7.0$ | — | 18.0 | ns |
| 154 | $\overline{\text{RD}}$ deassertion to data not valid ⁶ | t_{GZ} | | 0.0 | — | ns |
| 155 | $\overline{\text{WR}}$ assertion to data active | | $0.75 \times T_{\text{C}} - 0.3$ | 7.2 | — | ns |
| 156 | $\overline{\text{WR}}$ deassertion to data high impedance | | $0.25 \times T_{\text{C}}$ | — | 2.5 | ns |

¹ The number of wait states for Page mode access is specified in the DCR.

² The refresh period is specified in the DCR.

³ The asynchronous delays specified in the expressions are valid for DSP56362.

⁴ All the timings are calculated for the worst case. Some of the timings are better for specific cases (e.g., t_{PC} equals $4 \times T_{\text{C}}$ for read-after-read or write-after-write sequences).

⁵ BRW[1:0] (DRAM control register bits) defines the number of wait states that should be inserted in each DRAM out-of-page-access.

⁶ $\overline{\text{RD}}$ deassertion will always occur after $\overline{\text{CAS}}$ deassertion; therefore, the restricted timing is t_{OFF} and not t_{GZ} .

Table 3-12 DRAM Page Mode Timings, Four Wait States 100 and 120MHz^{1, 2, 3, 4}

| No. | Characteristics | Symbol | Expression | 100 MHz | | 120 MHz | | Unit |
|-----|--------------------------------------------------------------------------------------------------------------------------------------------------|------------|--------------------------------------------|---------|------|---------|------|------|
| | | | | Min | Max | Min | Max | |
| 131 | Page mode cycle time for two consecutive accesses of the same direction | t_{PC} | $5 \times T_C$ | 50.0 | — | 41.7 | | ns |
| | Page mode cycle time for mixed (read and write) accesses. | | $4.5 \times T_C$ | 45.0 | — | 37.5 | | |
| 132 | \overline{CAS} assertion to data valid (read) | t_{CAC} | 100 MHz: $2.75 \times T_C - 7.0$ | — | 20.5 | — | 15.9 | ns |
| 133 | Column address valid to data valid (read) | t_{AA} | 100 MHz: $3.75 \times T_C - 7.0$ | — | 30.5 | — | 24.2 | ns |
| 134 | \overline{CAS} deassertion to data not valid (read hold time) | t_{OFF} | | 0.0 | — | 0.0 | — | ns |
| 135 | Last \overline{CAS} assertion to \overline{RAS} deassertion | t_{RSH} | $3.5 \times T_C - 4.0$ | 31.0 | — | 25.2 | — | ns |
| 136 | Previous \overline{CAS} deassertion to \overline{RAS} deassertion | t_{RHCP} | $6 \times T_C - 4.0$ | 56.0 | — | 46.0 | — | ns |
| 137 | \overline{CAS} assertion pulse width | t_{CAS} | $2.5 \times T_C - 4.0$ | 21.0 | — | 16.8 | — | ns |
| 138 | Last \overline{CAS} deassertion to \overline{RAS} assertion ⁵ BRW[1:0] = 00 BRW[1:0] = 01 BRW[1:0] = 10 BRW[1:0] = 11 | t_{CRP} | $2.75 \times T_C - 6.0$ | — | — | — | — | ns |
| | | | $4.25 \times T_C - 6.0$ | — | — | — | — | |
| | | | $5.25 \times T_C - 6.0$ | 46.5 | — | 37.7 | — | |
| | | | $7.25 \times T_C - 6.0$ | 66.5 | — | 54.4 | — | |
| 139 | \overline{CAS} deassertion pulse width | t_{CP} | $2 \times T_C - 4.0$ | 16.0 | — | 12.7 | — | ns |
| 140 | Column address valid to \overline{CAS} assertion | t_{ASC} | $T_C - 4.0$ | 6.0 | — | 4.3 | — | ns |
| 141 | \overline{CAS} assertion to column address not valid | t_{CAH} | $3.5 \times T_C - 4.0$ | 31.0 | — | 25.2 | — | ns |
| 142 | Last column address valid to \overline{RAS} deassertion | t_{RAL} | $5 \times T_C - 4.0$ | 46.0 | — | 37.7 | — | ns |
| 143 | \overline{WR} deassertion to \overline{CAS} assertion | t_{RCS} | 100 MHz: $1.25 \times T_C - 4.0$ | 8.5 | — | 6.4 | — | ns |
| 144 | \overline{CAS} deassertion to \overline{WR} assertion | t_{RCH} | 100 MHz: $1.25 \times T_C - 4.0$ | 8.5 | — | 6.4 | — | ns |
| 145 | \overline{CAS} assertion to \overline{WR} deassertion | t_{WCH} | $3.25 \times T_C - 4.2$ | 28.3 | — | 22.9 | — | ns |
| 146 | \overline{WR} assertion pulse width | t_{WP} | $4.5 \times T_C - 4.5$ | 40.5 | — | 33.0 | — | ns |
| 147 | Last \overline{WR} assertion to \overline{RAS} deassertion | t_{RWL} | $4.75 \times T_C - 4.3$ | 43.2 | — | 35.3 | — | ns |
| 148 | \overline{WR} assertion to \overline{CAS} deassertion | t_{CWL} | $3.75 \times T_C - 4.3$ | 33.2 | — | 26.9 | — | ns |

Table 3-12 DRAM Page Mode Timings, Four Wait States 100 and 120MHz^{1, 2, 3, 4} (continued)

| No. | Characteristics | Symbol | Expression | 100 MHz | | 120 MHz | | Unit |
|-----|------------------------------------------------------------------------------|------------------|-----------------------------------------------------|---------|------|---------|------|------|
| | | | | Min | Max | Min | Max | |
| 149 | Data valid to $\overline{\text{CAS}}$ assertion (write) | t_{DS} | $0.5 \times T_{\text{C}} - 4.0$ | 1.0 | — | 0.2 | — | ns |
| 150 | $\overline{\text{CAS}}$ assertion to data not valid (write) | t_{DH} | $3.5 \times T_{\text{C}} - 4.0$ | 31.0 | — | 25.2 | — | ns |
| 151 | $\overline{\text{WR}}$ assertion to $\overline{\text{CAS}}$ assertion | t_{WCS} | $1.25 \times T_{\text{C}} - 4.3$ | 8.2 | — | 6.1 | — | ns |
| 152 | Last $\overline{\text{RD}}$ assertion to $\overline{\text{RAS}}$ deassertion | t_{ROH} | $4.5 \times T_{\text{C}} - 4.0$ | 41.0 | — | 33.5 | — | ns |
| 153 | $\overline{\text{RD}}$ assertion to data valid | t_{GA} | 100 MHz: $3.25 \times T_{\text{C}} - 7.0$ | — | 25.5 | — | 20.1 | ns |
| 154 | $\overline{\text{RD}}$ deassertion to data not valid ⁶ | t_{GZ} | | 0.0 | — | 0.0 | — | ns |
| 155 | $\overline{\text{WR}}$ assertion to data active | | $0.75 \times T_{\text{C}} - 0.3$ | 7.2 | — | 5.9 | | ns |
| 156 | $\overline{\text{WR}}$ deassertion to data high impedance | | $0.25 \times T_{\text{C}}$ | — | 2.5 | — | 2.1 | ns |

¹ The number of wait states for Page mode access is specified in the DCR.

² The refresh period is specified in the DCR.

³ The asynchronous delays specified in the expressions are valid for DSP56362.

⁴ All the timings are calculated for the worst case. Some of the timings are better for specific cases (e.g., t_{PC} equals $3 \times T_{\text{C}}$ for read-after-read or write-after-write sequences).

⁵ BRW[1:0] (DRAM control register bits) defines the number of wait states that should be inserted in each DRAM out-of-page access.

⁶ $\overline{\text{RD}}$ deassertion will always occur after $\overline{\text{CAS}}$ deassertion; therefore, the restricted timing is t_{OFF} and not t_{GZ} .

External Memory Expansion Port (Port A)

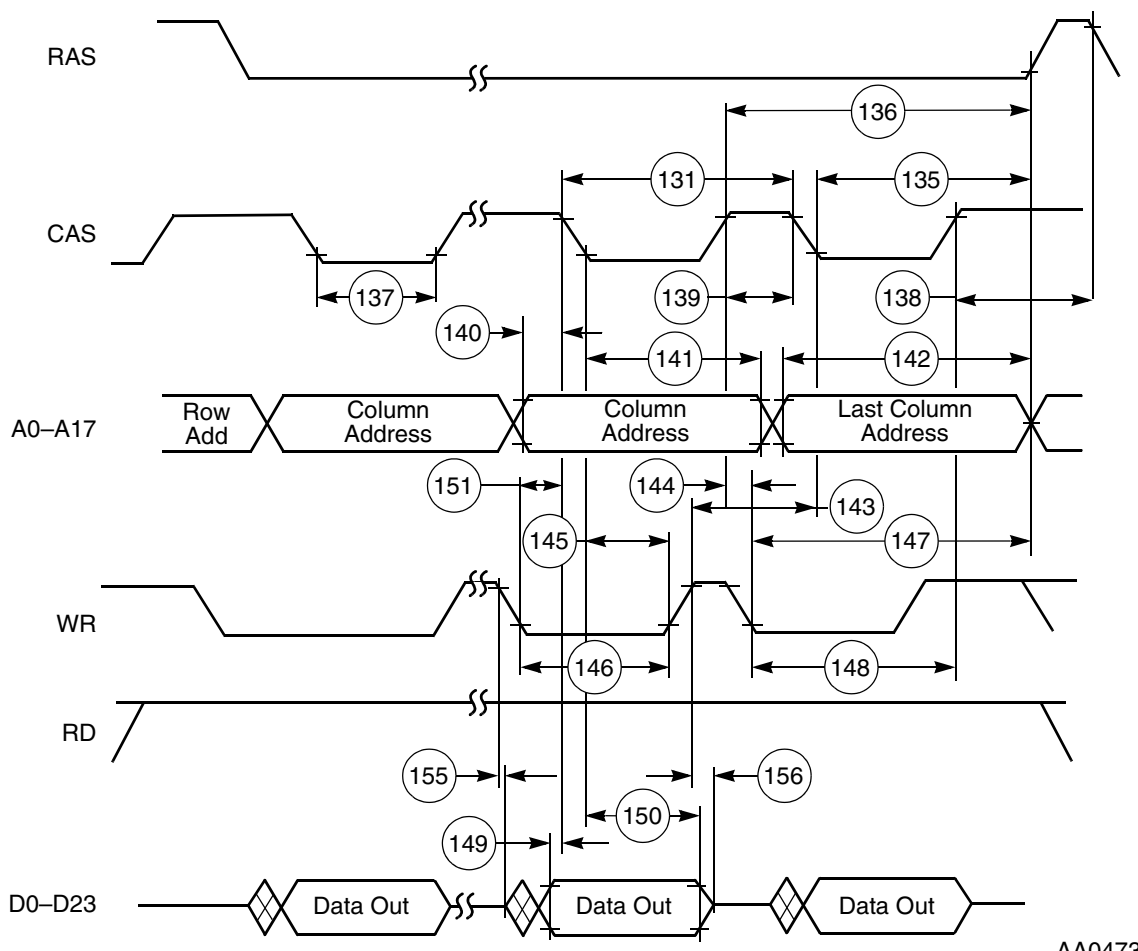

Figure 3-14 DRAM Page Mode Write Accesses

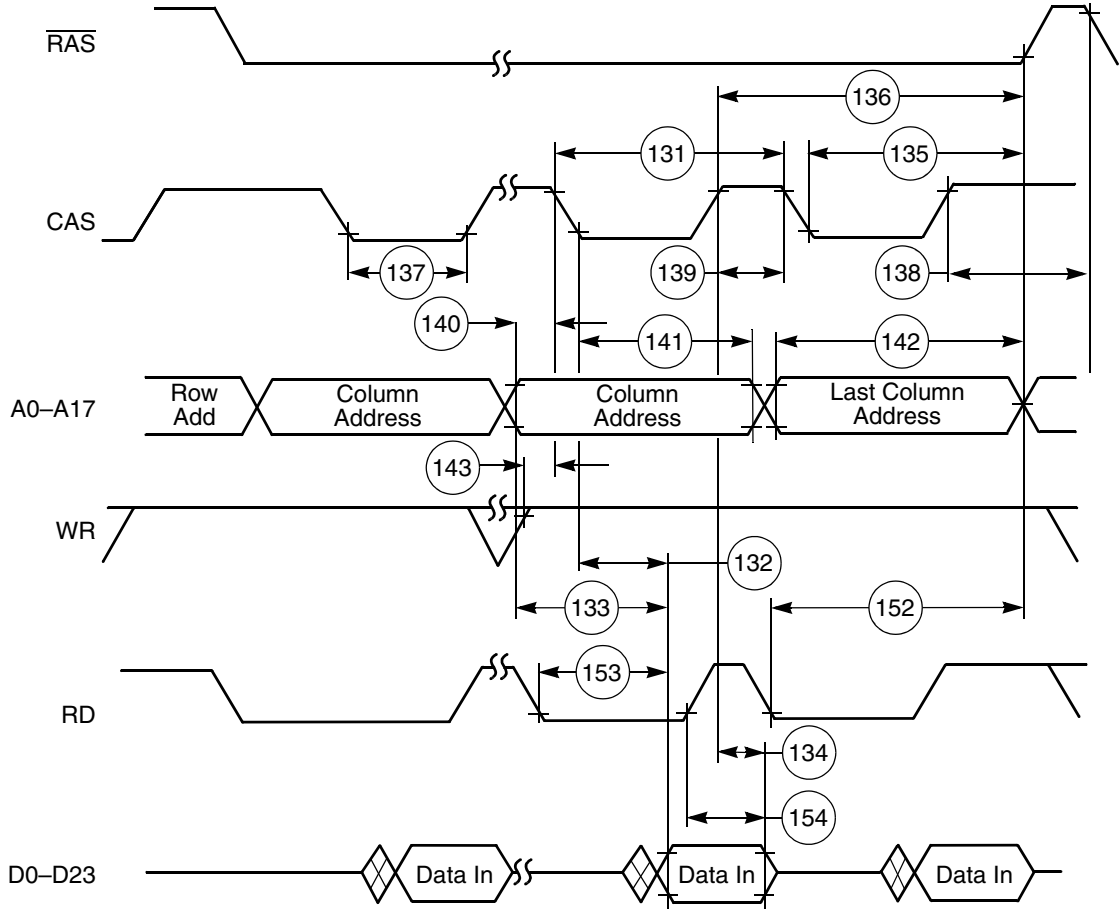

Figure 3-15 DRAM Page Mode Read Accesses

External Memory Expansion Port (Port A)

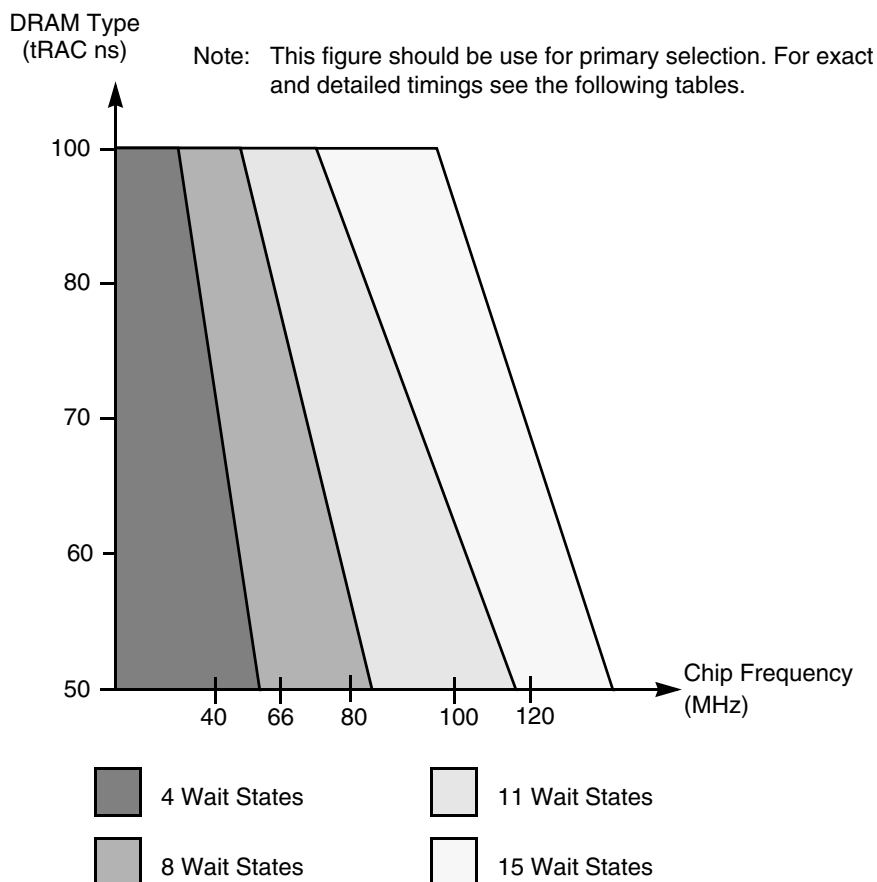

Figure 3-16 DRAM Out-of-Page Wait States Selection Guide

Table 3-13 DRAM Out-of-Page and Refresh Timings, Four Wait States^{1, 2}

| No. | Characteristics ³ | Symbol | Expression | 20 MHz ⁴ | | 30 MHz ⁴ | | Unit |
|-----|--------------------------------------------------------------------------|------------------|-----------------------------|---------------------|-------|---------------------|------|------|
| | | | | Min | Max | Min | Max | |
| 157 | Random read or write cycle time | t _{RC} | 5 × T _C | 250.0 | — | 166.7 | — | ns |
| 158 | $\overline{\text{RAS}}$ assertion to data valid (read) | t _{RAC} | 2.75 × T _C - 7.5 | — | 130.0 | — | 84.2 | ns |
| 159 | $\overline{\text{CAS}}$ assertion to data valid (read) | t _{CAC} | 1.25 × T _C - 7.5 | — | 55.0 | — | 34.2 | ns |
| 160 | Column address valid to data valid (read) | t _{AA} | 1.5 × T _C - 7.5 | — | 67.5 | — | 42.5 | ns |
| 161 | $\overline{\text{CAS}}$ deassertion to data not valid (read hold time) | t _{OFF} | | 0.0 | — | 0.0 | — | ns |
| 162 | $\overline{\text{RAS}}$ deassertion to $\overline{\text{RAS}}$ assertion | t _{RP} | 1.75 × T _C - 4.0 | 83.5 | — | 54.3 | — | ns |
| 163 | $\overline{\text{RAS}}$ assertion pulse width | t _{RAS} | 3.25 × T _C - 4.0 | 158.5 | — | 104.3 | — | ns |
| 164 | $\overline{\text{CAS}}$ assertion to $\overline{\text{RAS}}$ deassertion | t _{RSH} | 1.75 × T _C - 4.0 | 83.5 | — | 54.3 | — | ns |

Table 3-13 DRAM Out-of-Page and Refresh Timings, Four Wait States^{1, 2} (continued)

| No. | Characteristics ³ | Symbol | Expression | 20 MHz ⁴ | | 30 MHz ⁴ | | Unit |
|-----|------------------------------------------------------------------------------------|------------------|-------------------------|---------------------|------|---------------------|------|------|
| | | | | Min | Max | Min | Max | |
| 165 | $\overline{\text{RAS}}$ assertion to $\overline{\text{CAS}}$ deassertion | t_{CSH} | $2.75 \times T_C - 4.0$ | 133.5 | — | 87.7 | — | ns |
| 166 | $\overline{\text{CAS}}$ assertion pulse width | t_{CAS} | $1.25 \times T_C - 4.0$ | 58.5 | — | 37.7 | — | ns |
| 167 | $\overline{\text{RAS}}$ assertion to $\overline{\text{CAS}}$ assertion | t_{RCD} | $1.5 \times T_C \pm 2$ | 73.0 | 77.0 | 48.0 | 52.0 | ns |
| 168 | $\overline{\text{RAS}}$ assertion to column address valid | t_{RAD} | $1.25 \times T_C \pm 2$ | 60.5 | 64.5 | 39.7 | 43.7 | ns |
| 169 | $\overline{\text{CAS}}$ deassertion to $\overline{\text{RAS}}$ assertion | t_{CRP} | $2.25 \times T_C - 4.0$ | 108.5 | — | 71.0 | — | ns |
| 170 | $\overline{\text{CAS}}$ deassertion pulse width | t_{CP} | $1.75 \times T_C - 4.0$ | 83.5 | — | 54.3 | — | ns |
| 171 | Row address valid to $\overline{\text{RAS}}$ assertion | t_{ASR} | $1.75 \times T_C - 4.0$ | 83.5 | — | 54.3 | — | ns |
| 172 | $\overline{\text{RAS}}$ assertion to row address not valid | t_{RAH} | $1.25 \times T_C - 4.0$ | 58.5 | — | 37.7 | — | ns |
| 173 | Column address valid to $\overline{\text{CAS}}$ assertion | t_{ASC} | $0.25 \times T_C - 4.0$ | 8.5 | — | 4.3 | — | ns |
| 174 | $\overline{\text{CAS}}$ assertion to column address not valid | t_{CAH} | $1.75 \times T_C - 4.0$ | 83.5 | — | 54.3 | — | ns |
| 175 | $\overline{\text{RAS}}$ assertion to column address not valid | t_{AR} | $3.25 \times T_C - 4.0$ | 158.5 | — | 104.3 | — | ns |
| 176 | Column address valid to $\overline{\text{RAS}}$ deassertion | t_{RAL} | $2 \times T_C - 4.0$ | 96.0 | — | 62.7 | — | ns |
| 177 | $\overline{\text{WR}}$ deassertion to $\overline{\text{CAS}}$ assertion | t_{RCS} | $1.5 \times T_C - 3.8$ | 71.2 | — | 46.2 | — | ns |
| 178 | $\overline{\text{CAS}}$ deassertion to $\overline{\text{WR}}$ assertion | t_{RCH} | $0.75 \times T_C - 3.7$ | 33.8 | — | 21.3 | — | ns |
| 179 | $\overline{\text{RAS}}$ deassertion to $\overline{\text{WR}}$ assertion | t_{RRH} | $0.25 \times T_C - 3.7$ | 8.8 | — | 4.6 | — | ns |
| 180 | $\overline{\text{CAS}}$ assertion to $\overline{\text{WR}}$ deassertion | t_{WCH} | $1.5 \times T_C - 4.2$ | 70.8 | — | 45.8 | — | ns |
| 181 | $\overline{\text{RAS}}$ assertion to $\overline{\text{WR}}$ deassertion | t_{WCR} | $3 \times T_C - 4.2$ | 145.8 | — | 95.8 | — | ns |
| 182 | $\overline{\text{WR}}$ assertion pulse width | t_{WP} | $4.5 \times T_C - 4.5$ | 220.5 | — | 145.5 | — | ns |
| 183 | $\overline{\text{WR}}$ assertion to $\overline{\text{RAS}}$ deassertion | t_{RWL} | $4.75 \times T_C - 4.3$ | 233.2 | — | 154.0 | — | ns |
| 184 | $\overline{\text{WR}}$ assertion to $\overline{\text{CAS}}$ deassertion | t_{CWL} | $4.25 \times T_C - 4.3$ | 208.2 | — | 137.4 | — | ns |
| 185 | Data valid to $\overline{\text{CAS}}$ assertion (write) | t_{DS} | $2.25 \times T_C - 4.0$ | 108.5 | — | 71.0 | — | ns |
| 186 | $\overline{\text{CAS}}$ assertion to data not valid (write) | t_{DH} | $1.75 \times T_C - 4.0$ | 83.5 | — | 54.3 | — | ns |
| 187 | $\overline{\text{RAS}}$ assertion to data not valid (write) | t_{DHR} | $3.25 \times T_C - 4.0$ | 158.5 | — | 104.3 | — | ns |
| 188 | $\overline{\text{WR}}$ assertion to $\overline{\text{CAS}}$ assertion | t_{WCS} | $3 \times T_C - 4.3$ | 145.7 | — | 95.7 | — | ns |
| 189 | $\overline{\text{CAS}}$ assertion to $\overline{\text{RAS}}$ assertion (refresh) | t_{CSR} | $0.5 \times T_C - 4.0$ | 21.0 | — | 12.7 | — | ns |
| 190 | $\overline{\text{RAS}}$ deassertion to $\overline{\text{CAS}}$ assertion (refresh) | t_{RPC} | $1.25 \times T_C - 4.0$ | 58.5 | — | 37.7 | — | ns |

Table 3-13 DRAM Out-of-Page and Refresh Timings, Four Wait States^{1, 2} (continued)

| No. | Characteristics ³ | Symbol | Expression | 20 MHz ⁴ | | 30 MHz ⁴ | | Unit |
|-----|------------------------------------------------------------|-----------|-------------------------|---------------------|-------|---------------------|-------|------|
| | | | | Min | Max | Min | Max | |
| 191 | \overline{RD} assertion to \overline{RAS} deassertion | t_{ROH} | $4.5 \times T_C - 4.0$ | 221.0 | — | 146.0 | — | ns |
| 192 | \overline{RD} assertion to data valid | t_{GA} | $4 \times T_C - 7.5$ | — | 192.5 | — | 125.8 | ns |
| 193 | \overline{RD} deassertion to data not valid ³ | t_{GZ} | | 0.0 | — | 0.0 | — | ns |
| 194 | \overline{WR} assertion to data active | | $0.75 \times T_C - 0.3$ | 37.2 | — | 24.7 | — | ns |
| 195 | \overline{WR} deassertion to data high impedance | | $0.25 \times T_C$ | — | 12.5 | — | 8.3 | ns |

¹ The number of wait states for out of page access is specified in the DCR.

² The refresh period is specified in the DCR.

³ \overline{RD} deassertion will always occur after \overline{CAS} deassertion; therefore, the restricted timing is t_{OFF} and not t_{GZ} .

⁴ Reduced DSP clock speed allows use of DRAM out-of-page access with four Wait states. See [Figure 3-16](#).

Table 3-14 DRAM Out-of-Page and Refresh Timings, Eight Wait States^{1, 2}

| No. | Characteristics ³ | Symbol | Expression ⁴ | 80 MHz | | Unit |
|-----|-----------------------------------------------------------------|-----------|-------------------------|--------|------|------|
| | | | | Min | Max | |
| 157 | Random read or write cycle time | t_{RC} | $9 \times T_C$ | 112.5 | — | ns |
| 158 | \overline{RAS} assertion to data valid (read) | t_{RAC} | $4.75 \times T_C - 6.5$ | | 52.9 | ns |
| 159 | \overline{CAS} assertion to data valid (read) | t_{CAC} | $2.25 \times T_C - 6.5$ | — | 21.6 | ns |
| 160 | Column address valid to data valid (read) | t_{AA} | $3 \times T_C - 6.5$ | — | 31.0 | ns |
| 161 | \overline{CAS} deassertion to data not valid (read hold time) | t_{OFF} | | 0.0 | — | ns |
| 162 | \overline{RAS} deassertion to \overline{RAS} assertion | t_{RP} | $3.25 \times T_C - 4.0$ | 36.6 | — | ns |
| 163 | \overline{RAS} assertion pulse width | t_{RAS} | $5.75 \times T_C - 4.0$ | 67.9 | — | ns |
| 164 | \overline{CAS} assertion to \overline{RAS} deassertion | t_{RSH} | $3.25 \times T_C - 4.0$ | 36.6 | — | ns |
| 165 | \overline{RAS} assertion to \overline{CAS} deassertion | t_{CSH} | $4.75 \times T_C - 4.0$ | 55.4 | — | ns |
| 166 | \overline{CAS} assertion pulse width | t_{CAS} | $2.25 \times T_C - 4.0$ | 24.1 | — | ns |
| 167 | \overline{RAS} assertion to \overline{CAS} assertion | t_{RCD} | $2.5 \times T_C \pm 2$ | 29.3 | 33.3 | ns |
| 168 | \overline{RAS} assertion to column address valid | t_{RAD} | $1.75 \times T_C \pm 2$ | 19.9 | 23.9 | ns |
| 169 | \overline{CAS} deassertion to \overline{RAS} assertion | t_{CRP} | $4.25 \times T_C - 4.0$ | 49.1 | — | ns |
| 170 | \overline{CAS} deassertion pulse width | t_{CP} | $2.75 \times T_C - 4.0$ | 30.4 | — | ns |
| 171 | Row address valid to \overline{RAS} assertion | t_{ASR} | $3.25 \times T_C - 4.0$ | 36.6 | — | ns |

Table 3-14 DRAM Out-of-Page and Refresh Timings, Eight Wait States^{1,2} (continued)

| No. | Characteristics ³ | Symbol | Expression ⁴ | 80 MHz | | Unit |
|-----|--------------------------------------------------------------------------------------|------------------|-------------------------|--------|------|------|
| | | | | Min | Max | |
| 172 | $\overline{\text{RAS}}$ assertion to row address not valid | t_{RAH} | $1.75 \times T_C - 4.0$ | 17.9 | — | ns |
| 173 | Column address valid to $\overline{\text{CAS}}$ assertion | t_{ASC} | $0.75 \times T_C - 4.0$ | 5.4 | — | ns |
| 174 | $\overline{\text{CAS}}$ assertion to column address not valid | t_{CAH} | $3.25 \times T_C - 4.0$ | 36.6 | — | ns |
| 175 | $\overline{\text{RAS}}$ assertion to column address not valid | t_{AR} | $5.75 \times T_C - 4.0$ | 67.9 | — | ns |
| 176 | Column address valid to $\overline{\text{RAS}}$ deassertion | t_{RAL} | $4 \times T_C - 4.0$ | 46.0 | — | ns |
| 177 | $\overline{\text{WR}}$ deassertion to $\overline{\text{CAS}}$ assertion | t_{RCS} | $2 \times T_C - 3.8$ | 21.2 | — | ns |
| 178 | $\overline{\text{CAS}}$ deassertion to $\overline{\text{WR}}$ ⁵ assertion | t_{RCH} | $1.25 \times T_C - 3.7$ | 11.9 | — | ns |
| 179 | $\overline{\text{RAS}}$ deassertion to $\overline{\text{WR}}$ ⁵ assertion | t_{RRH} | $0.25 \times T_C - 3.0$ | 0.1 | — | ns |
| 180 | $\overline{\text{CAS}}$ assertion to $\overline{\text{WR}}$ deassertion | t_{WCH} | $3 \times T_C - 4.2$ | 33.3 | — | ns |
| 181 | $\overline{\text{RAS}}$ assertion to $\overline{\text{WR}}$ deassertion | t_{WCR} | $5.5 \times T_C - 4.2$ | 64.6 | — | ns |
| 182 | $\overline{\text{WR}}$ assertion pulse width | t_{WP} | $8.5 \times T_C - 4.5$ | 101.8 | — | ns |
| 183 | $\overline{\text{WR}}$ assertion to $\overline{\text{RAS}}$ deassertion | t_{RWL} | $8.75 \times T_C - 4.3$ | 105.1 | — | ns |
| 184 | $\overline{\text{WR}}$ assertion to $\overline{\text{CAS}}$ deassertion | t_{CWL} | $7.75 \times T_C - 4.3$ | 92.6 | — | ns |
| 185 | Data valid to $\overline{\text{CAS}}$ assertion (write) | t_{DS} | $4.75 \times T_C - 4.0$ | 55.4 | — | ns |
| 186 | $\overline{\text{CAS}}$ assertion to data not valid (write) | t_{DH} | $3.25 \times T_C - 4.0$ | 36.6 | — | ns |
| 187 | $\overline{\text{RAS}}$ assertion to data not valid (write) | t_{DHR} | $5.75 \times T_C - 4.0$ | 67.9 | — | ns |
| 188 | $\overline{\text{WR}}$ assertion to $\overline{\text{CAS}}$ assertion | t_{WCS} | $5.5 \times T_C - 4.3$ | 64.5 | — | ns |
| 189 | $\overline{\text{CAS}}$ assertion to $\overline{\text{RAS}}$ assertion (refresh) | t_{CSR} | $1.5 \times T_C - 4.0$ | 14.8 | — | ns |
| 190 | $\overline{\text{RAS}}$ deassertion to $\overline{\text{CAS}}$ assertion (refresh) | t_{RPC} | $1.75 \times T_C - 4.0$ | 17.9 | — | ns |
| 191 | $\overline{\text{RD}}$ assertion to $\overline{\text{RAS}}$ deassertion | t_{ROH} | $8.5 \times T_C - 4.0$ | 102.3 | — | ns |
| 192 | $\overline{\text{RD}}$ assertion to data valid | t_{GA} | $7.5 \times T_C - 6.5$ | — | 87.3 | ns |
| 193 | $\overline{\text{RD}}$ deassertion to data not valid ³ | t_{GZ} | 0.0 | 0.0 | — | ns |
| 194 | $\overline{\text{WR}}$ assertion to data active | | $0.75 \times T_C - 0.3$ | 9.1 | — | ns |
| 195 | $\overline{\text{WR}}$ deassertion to data high impedance | | $0.25 \times T_C$ | — | 3.1 | ns |

¹ The number of wait states for out-of-page access is specified in the DCR.

² The refresh period is specified in the DCR.

³ $\overline{\text{RD}}$ deassertion will always occur after $\overline{\text{CAS}}$ deassertion; therefore, the restricted timing is t_{OFF} and not t_{GZ} .

⁴ The asynchronous delays specified in the expressions are valid for DSP56362.

⁵ Either t_{RCH} or t_{RRH} must be satisfied for read cycles.

Table 3-15 DRAM Out-of-Page and Refresh Timings, Eleven Wait States^{1, 2}

| No. | Characteristics ³ | Symbol | Expression ⁴ | 100 MHz | | Unit |
|-----|-----------------------------------------------------------------|-----------|---------------------------|---------|------|------|
| | | | | Min | Max | |
| 157 | Random read or write cycle time | t_{RC} | $12 \times T_C$ | 120.0 | — | ns |
| 158 | \overline{RAS} assertion to data valid (read) | t_{RAC} | $6.25 \times T_C - 7.0$ | — | 55.5 | ns |
| 159 | \overline{CAS} assertion to data valid (read) | t_{CAC} | $3.75 \times T_C - 7.0$ | — | 30.5 | ns |
| 160 | Column address valid to data valid (read) | t_{AA} | $4.5 \times T_C - 7.0$ | — | 38.0 | ns |
| 161 | \overline{CAS} deassertion to data not valid (read hold time) | t_{OFF} | | 0.0 | — | ns |
| 162 | \overline{RAS} deassertion to \overline{RAS} assertion | t_{RP} | $4.25 \times T_C - 4.0$ | 38.5 | — | ns |
| 163 | \overline{RAS} assertion pulse width | t_{RAS} | $7.75 \times T_C - 4.0$ | 73.5 | — | ns |
| 164 | \overline{CAS} assertion to \overline{RAS} deassertion | t_{RSH} | $5.25 \times T_C - 4.0$ | 48.5 | — | ns |
| 165 | \overline{RAS} assertion to \overline{CAS} deassertion | t_{CSH} | $6.25 \times T_C - 4.0$ | 58.5 | — | ns |
| 166 | \overline{CAS} assertion pulse width | t_{CAS} | $3.75 \times T_C - 4.0$ | 33.5 | — | ns |
| 167 | \overline{RAS} assertion to \overline{CAS} assertion | t_{RCD} | $2.5 \times T_C \pm 4.0$ | 21.0 | 29.0 | ns |
| 168 | \overline{RAS} assertion to column address valid | t_{RAD} | $1.75 \times T_C \pm 4.0$ | 13.5 | 21.5 | ns |
| 169 | \overline{CAS} deassertion to \overline{RAS} assertion | t_{CRP} | $5.75 \times T_C - 4.0$ | 53.5 | — | ns |
| 170 | \overline{CAS} deassertion pulse width | t_{CP} | $4.25 \times T_C - 4.0$ | 38.5 | — | ns |
| 171 | Row address valid to \overline{RAS} assertion | t_{ASR} | $4.25 \times T_C - 4.0$ | 38.5 | — | ns |
| 172 | \overline{RAS} assertion to row address not valid | t_{RAH} | $1.75 \times T_C - 4.0$ | 13.5 | — | ns |
| 173 | Column address valid to \overline{CAS} assertion | t_{ASC} | $0.75 \times T_C - 4.0$ | 3.5 | — | ns |
| 174 | \overline{CAS} assertion to column address not valid | t_{CAH} | $5.25 \times T_C - 4.0$ | 48.5 | — | ns |
| 175 | \overline{RAS} assertion to column address not valid | t_{AR} | $7.75 \times T_C - 4.0$ | 73.5 | — | ns |
| 176 | Column address valid to \overline{RAS} deassertion | t_{RAL} | $6 \times T_C - 4.0$ | 56.0 | — | ns |
| 177 | \overline{WR} deassertion to \overline{CAS} assertion | t_{RCS} | $3.0 \times T_C - 4.0$ | 26.0 | — | ns |
| 178 | \overline{CAS} deassertion to \overline{WR}^5 assertion | t_{RCH} | $1.75 \times T_C - 4.0$ | 13.5 | — | ns |
| 179 | \overline{RAS} deassertion to \overline{WR}^5 assertion | | $0.25 \times T_C - 3.0$ | — | — | ns |
| | | | $0.25 \times T_C - 2.0$ | 0.5 | — | |
| 180 | \overline{CAS} assertion to \overline{WR} deassertion | t_{WCH} | $5 \times T_C - 4.2$ | 45.8 | — | ns |
| 181 | \overline{RAS} assertion to \overline{WR} deassertion | t_{WCR} | $7.5 \times T_C - 4.2$ | 70.8 | — | ns |

Table 3-15 DRAM Out-of-Page and Refresh Timings, Eleven Wait States^{1, 2} (continued)

| No. | Characteristics ³ | Symbol | Expression ⁴ | 100 MHz | | Unit |
|-----|----------------------------------------------------------------------|-----------|--------------------------|---------|------|------|
| | | | | Min | Max | |
| 182 | \overline{WR} assertion pulse width | t_{WP} | $11.5 \times T_C - 4.5$ | 110.5 | — | ns |
| 183 | \overline{WR} assertion to \overline{RAS} deassertion | t_{RWL} | $11.75 \times T_C - 4.3$ | 113.2 | — | ns |
| 184 | \overline{WR} assertion to \overline{CAS} deassertion | t_{CWL} | $10.25 \times T_C - 4.3$ | 103.2 | — | ns |
| 185 | Data valid to \overline{CAS} assertion (write) | t_{DS} | $5.75 \times T_C - 4.0$ | 53.5 | — | ns |
| 186 | \overline{CAS} assertion to data not valid (write) | t_{DH} | $5.25 \times T_C - 4.0$ | 48.5 | — | ns |
| 187 | \overline{RAS} assertion to data not valid (write) | t_{DHR} | $7.75 \times T_C - 4.0$ | 73.5 | — | ns |
| 188 | \overline{WR} assertion to \overline{CAS} assertion | t_{WCS} | $6.5 \times T_C - 4.3$ | 60.7 | — | ns |
| 189 | \overline{CAS} assertion to \overline{RAS} assertion (refresh) | t_{CSR} | $1.5 \times T_C - 4.0$ | 11.0 | — | ns |
| 190 | \overline{RAS} deassertion to \overline{CAS} assertion (refresh) | t_{RPC} | $2.75 \times T_C - 4.0$ | 23.5 | — | ns |
| 191 | \overline{RD} assertion to \overline{RAS} deassertion | t_{ROH} | $11.5 \times T_C - 4.0$ | 111.0 | — | ns |
| 192 | \overline{RD} assertion to data valid | t_{GA} | $10 \times T_C - 7.0$ | | 93.0 | ns |
| 193 | \overline{RD} deassertion to data not valid ³ | t_{GZ} | | 0.0 | — | ns |
| 194 | \overline{WR} assertion to data active | | $0.75 \times T_C - 0.3$ | 7.2 | — | ns |
| 195 | \overline{WR} deassertion to data high impedance | | $0.25 \times T_C$ | — | 2.5 | ns |

¹ The number of wait states for out-of-page access is specified in the DCR.

² The refresh period is specified in the DCR.

³ \overline{RD} deassertion will always occur after \overline{CAS} deassertion; therefore, the restricted timing is t_{OFF} and not t_{GZ} .

⁴ The asynchronous delays specified in the expressions are valid for DSP56362.

⁵ Either t_{RCH} or t_{RRH} must be satisfied for read cycles.

Table 3-16 DRAM Out-of-Page and Refresh Timings, Fifteen Wait States 100 and 120MHz^{1, 2}

| No. | Characteristics ³ | Symbol | Expression | 100 MHz | | 120 MHz | | Unit |
|-----|-------------------------------------------------|-----------|-------------------------|---------|------|---------|------|------|
| | | | | Min | Max | Min | Max | |
| 157 | Random read or write cycle time | t_{RC} | $16 \times T_C$ | 160.0 | — | 133.3 | — | ns |
| 158 | \overline{RAS} assertion to data valid (read) | t_{RAC} | $8.25 \times T_C - 5.7$ | — | 76.8 | — | 63.0 | ns |
| 159 | \overline{CAS} assertion to data valid (read) | t_{CAC} | $4.75 \times T_C - 5.7$ | — | 41.8 | — | 33.9 | ns |
| 160 | Column address valid to data valid (read) | t_{AA} | $5.5 \times T_C - 5.7$ | — | 49.3 | | 40.1 | ns |

Table 3-16 DRAM Out-of-Page and Refresh Timings, Fifteen Wait States 100 and 120MHz^{1, 2} (continued)

| No. | Characteristics ³ | Symbol | Expression | 100 MHz | | 120 MHz | | Unit |
|-----|---------------------------------------------------------------------------|------------------|--------------------------|---------|------|---------|------|------|
| | | | | Min | Max | Min | Max | |
| 161 | $\overline{\text{CAS}}$ deassertion to data not valid (read hold time) | t_{OFF} | 0.0 | 0.0 | — | 0.0 | — | ns |
| 162 | $\overline{\text{RAS}}$ deassertion to $\overline{\text{RAS}}$ assertion | t_{RP} | $6.25 \times T_C - 4.0$ | 58.5 | — | 48.1 | — | ns |
| 163 | $\overline{\text{RAS}}$ assertion pulse width | t_{RAS} | $9.75 \times T_C - 4.0$ | 93.5 | — | 77.2 | — | ns |
| 164 | $\overline{\text{CAS}}$ assertion to $\overline{\text{RAS}}$ deassertion | t_{RSH} | $6.25 \times T_C - 4.0$ | 58.5 | — | 48.1 | — | ns |
| 165 | $\overline{\text{RAS}}$ assertion to $\overline{\text{CAS}}$ deassertion | t_{CSH} | $8.25 \times T_C - 4.0$ | 78.5 | — | 64.7 | — | ns |
| 166 | $\overline{\text{CAS}}$ assertion pulse width | t_{CAS} | $4.75 \times T_C - 4.0$ | 43.5 | — | 35.6 | — | ns |
| 167 | $\overline{\text{RAS}}$ assertion to $\overline{\text{CAS}}$ assertion | t_{RCD} | $3.5 \times T_C \pm 2$ | 33.0 | 37.0 | 27.2 | 31.2 | ns |
| 168 | $\overline{\text{RAS}}$ assertion to column address valid | t_{RAD} | $2.75 \times T_C \pm 2$ | 25.5 | 29.5 | 20.9 | 24.9 | ns |
| 169 | $\overline{\text{CAS}}$ deassertion to $\overline{\text{RAS}}$ assertion | t_{CRP} | $7.75 \times T_C - 4.0$ | 73.5 | — | 60.6 | — | ns |
| 170 | $\overline{\text{CAS}}$ deassertion pulse width | t_{CP} | $6.25 \times T_C - 4.0$ | 58.5 | — | 48.1 | — | ns |
| 171 | Row address valid to $\overline{\text{RAS}}$ assertion | t_{ASR} | $6.25 \times T_C - 4.0$ | 58.5 | — | 48.1 | — | ns |
| 172 | $\overline{\text{RAS}}$ assertion to row address not valid | t_{RAH} | $2.75 \times T_C - 4.0$ | 23.5 | — | 18.9 | — | ns |
| 173 | Column address valid to $\overline{\text{CAS}}$ assertion | t_{ASC} | $0.75 \times T_C - 4.0$ | 3.5 | — | 2.2 | — | ns |
| 174 | $\overline{\text{CAS}}$ assertion to column address not valid | t_{CAH} | $6.25 \times T_C - 4.0$ | 58.5 | — | 48.1 | — | ns |
| 175 | $\overline{\text{RAS}}$ assertion to column address not valid | t_{AR} | $9.75 \times T_C - 4.0$ | 93.5 | — | 77.2 | — | ns |
| 176 | Column address valid to $\overline{\text{RAS}}$ deassertion | t_{RAL} | $7 \times T_C - 4.0$ | 66.0 | — | 54.3 | — | ns |
| 177 | $\overline{\text{WR}}$ deassertion to $\overline{\text{CAS}}$ assertion | t_{RCS} | $5 \times T_C - 3.8$ | 46.2 | — | 37.9 | — | ns |
| 178 | $\overline{\text{CAS}}$ deassertion to $\overline{\text{WR}}^4$ assertion | t_{RCH} | $1.75 \times T_C - 3.7$ | 13.8 | — | 10.9 | — | ns |
| 179 | $\overline{\text{RAS}}$ deassertion to $\overline{\text{WR}}^4$ assertion | t_{RRH} | $0.25 \times T_C - 2.0$ | 0.5 | — | 0.1 | — | ns |
| 180 | $\overline{\text{CAS}}$ assertion to $\overline{\text{WR}}$ deassertion | t_{WCH} | $6 \times T_C - 4.2$ | 55.8 | — | 45.8 | — | ns |
| 181 | $\overline{\text{RAS}}$ assertion to $\overline{\text{WR}}$ deassertion | t_{WCR} | $9.5 \times T_C - 4.2$ | 90.8 | — | 75.0 | — | ns |
| 182 | $\overline{\text{WR}}$ assertion pulse width | t_{WP} | $15.5 \times T_C - 4.5$ | 150.5 | — | 124.7 | — | ns |
| 183 | $\overline{\text{WR}}$ assertion to $\overline{\text{RAS}}$ deassertion | t_{RWL} | $15.75 \times T_C - 4.3$ | 153.2 | — | 126.9 | — | ns |
| 184 | $\overline{\text{WR}}$ assertion to $\overline{\text{CAS}}$ deassertion | t_{CWL} | $14.25 \times T_C - 4.3$ | 138.2 | — | 114.4 | — | ns |
| 185 | Data valid to $\overline{\text{CAS}}$ assertion (write) | t_{DS} | $8.75 \times T_C - 4.0$ | 83.5 | — | 68.9 | — | ns |

Table 3-16 DRAM Out-of-Page and Refresh Timings, Fifteen Wait States 100 and 120MHz^{1, 2} (continued)

| No. | Characteristics ³ | Symbol | Expression | 100 MHz | | 120 MHz | | Unit |
|-----|------------------------------------------------------------------------------------|------------------|----------------------------------|---------|-------|---------|-------|------|
| | | | | Min | Max | Min | Max | |
| 186 | $\overline{\text{CAS}}$ assertion to data not valid (write) | t_{DH} | $6.25 \times T_{\text{C}} - 4.0$ | 58.5 | — | 48.1 | — | ns |
| 187 | $\overline{\text{RAS}}$ assertion to data not valid (write) | t_{DHR} | $9.75 \times T_{\text{C}} - 4.0$ | 93.5 | — | 77.2 | — | ns |
| 188 | $\overline{\text{WR}}$ assertion to $\overline{\text{CAS}}$ assertion | t_{WCS} | $9.5 \times T_{\text{C}} - 4.3$ | 90.7 | — | 74.9 | — | ns |
| 189 | $\overline{\text{CAS}}$ assertion to $\overline{\text{RAS}}$ assertion (refresh) | t_{CSR} | $1.5 \times T_{\text{C}} - 4.0$ | 11.0 | — | 8.5 | — | ns |
| 190 | $\overline{\text{RAS}}$ deassertion to $\overline{\text{CAS}}$ assertion (refresh) | t_{RPC} | $4.75 \times T_{\text{C}} - 4.0$ | 43.5 | — | 35.6 | — | ns |
| 191 | $\overline{\text{RD}}$ assertion to $\overline{\text{RAS}}$ deassertion | t_{ROH} | $15.5 \times T_{\text{C}} - 4.0$ | 151.0 | — | 125.2 | — | ns |
| 192 | $\overline{\text{RD}}$ assertion to data valid | t_{GA} | $14 \times T_{\text{C}} - 5.7$ | — | 134.3 | — | 111.0 | ns |
| 193 | $\overline{\text{RD}}$ deassertion to data not valid ³ | t_{GZ} | | 0.0 | — | 0.0 | — | ns |
| 194 | $\overline{\text{WR}}$ assertion to data active | | $0.75 \times T_{\text{C}} - 0.3$ | 7.2 | — | 5.9 | — | ns |
| 195 | $\overline{\text{WR}}$ deassertion to data high impedance | | $0.25 \times T_{\text{C}}$ | — | 2.5 | — | 2.1 | ns |

¹ The number of wait states for out-of-page access is specified in the DCR.

² The refresh period is specified in the DCR.

³ $\overline{\text{RD}}$ deassertion will always occur after $\overline{\text{CAS}}$ deassertion; therefore, the restricted timing is t_{OFF} and not t_{GZ} .

⁴ Either t_{RCH} or t_{RRH} must be satisfied for read cycles.

External Memory Expansion Port (Port A)

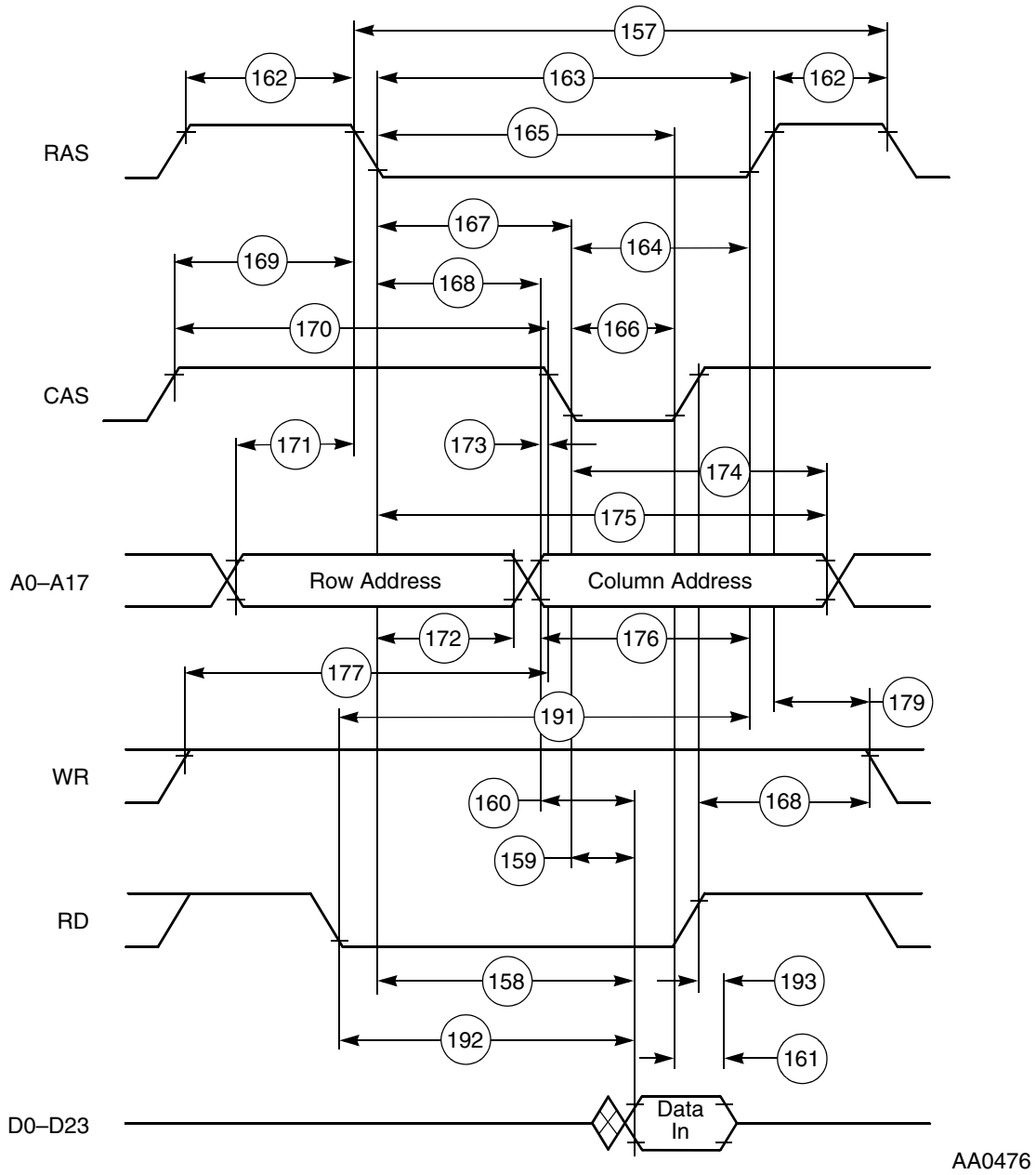

Figure 3-17 DRAM Out-of-Page Read Access

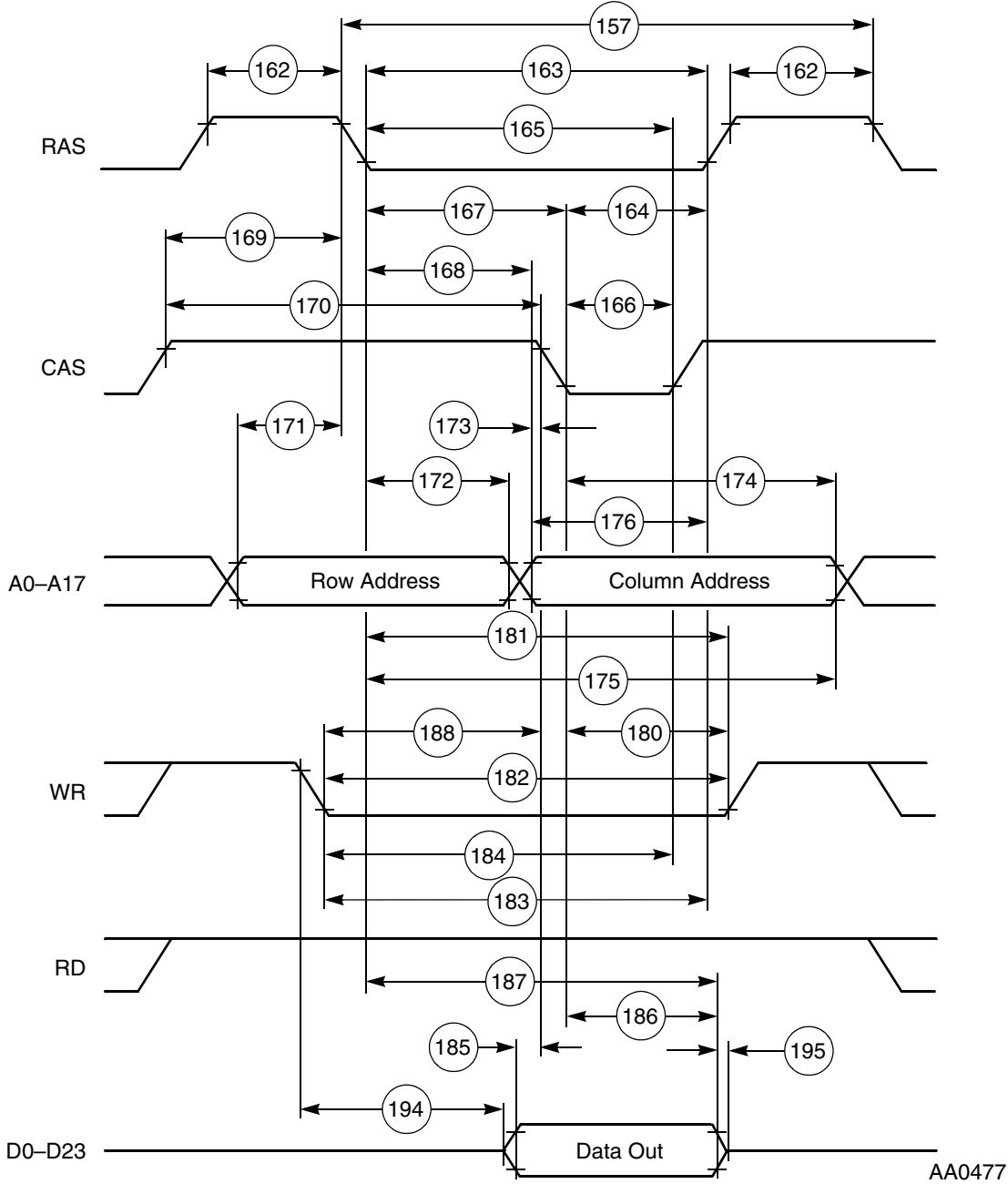

Figure 3-18 DRAM Out-of-Page Write Access

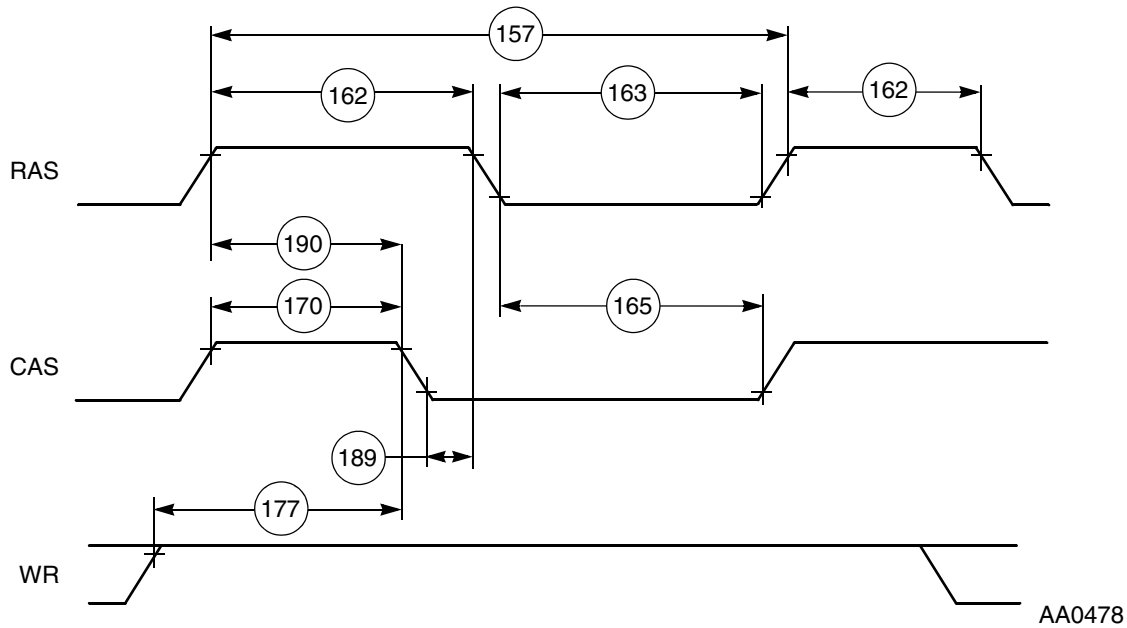

Figure 3-19 DRAM Refresh Access

3.10.3 Synchronous Timings (SRAM)

Table 3-17 External Bus Synchronous Timings (SRAM Access)¹

| No. | Characteristics | Expression ^{2, 3} | 100 MHz | | Unit |
|-----|-----------------------------------------------------|----------------------------|---------|------|------|
| | | | Min | Max | |
| 198 | CLKOUT high to address, and AA valid ⁴ | $0.25 \times T_C + 4.0$ | — | 6.5 | ns |
| 199 | CLKOUT high to address, and AA invalid ⁴ | $0.25 \times T_C$ | 2.5 | — | ns |
| 200 | \overline{TA} valid to CLKOUT high (setup time) | | 4.0 | — | ns |
| 201 | CLKOUT high to \overline{TA} invalid (hold time) | | 0.0 | — | ns |
| 202 | CLKOUT high to data out active | $0.25 \times T_C$ | 2.5 | — | ns |
| 203 | CLKOUT high to data out valid | $0.25 \times T_C + 4.0$ | 3.3 | 6.5 | ns |
| 204 | CLKOUT high to data out invalid | $0.25 \times T_C$ | 2.5 | — | ns |
| 205 | CLKOUT high to data out high impedance | $0.25 \times T_C$ | — | 2.5 | ns |
| 206 | Data in valid to CLKOUT high (setup) | | 4.0 | — | ns |
| 207 | CLKOUT high to data in invalid (hold) | | 0.0 | — | ns |
| 208 | CLKOUT high to \overline{RD} assertion | $0.75 \times T_C + 4.0$ | 8.2 | 11.5 | ns |

Table 3-17 External Bus Synchronous Timings (SRAM Access)¹ (continued)

| No. | Characteristics | Expression ^{2, 3} | 100 MHz | | Unit |
|-----|-------------------------------------------------------|------------------------------------------------------|---------|-----|------|
| | | | Min | Max | |
| 209 | CLKOUT high to \overline{RD} deassertion | | 0.0 | 4.0 | ns |
| 210 | CLKOUT high to \overline{WR} assertion ⁵ | $0.5 \times T_C + 4.3$ [WS = 1 or WS \geq 4] | 6.3 | 9.3 | ns |
| | | All frequencies: [2 \leq WS \leq 3] | 1.3 | 4.3 | |
| 211 | CLKOUT high to \overline{WR} deassertion | | 0.0 | 3.8 | ns |

¹ External bus synchronous timings should be used only for reference to the clock and *not* for relative timings.

² WS is the number of wait states specified in the BCR.

³ The asynchronous delays specified in the expressions are valid for DSP56362.

⁴ T198 and T199 are valid for Address Trace mode if the ATE bit in the OMR is set. Use the status of \overline{BR} (See T212) to determine whether the access referenced by A0–A23 is internal or external, when this mode is enabled

⁵ If WS > 1, \overline{WR} assertion refers to the next rising edge of CLKOUT.

External Memory Expansion Port (Port A)

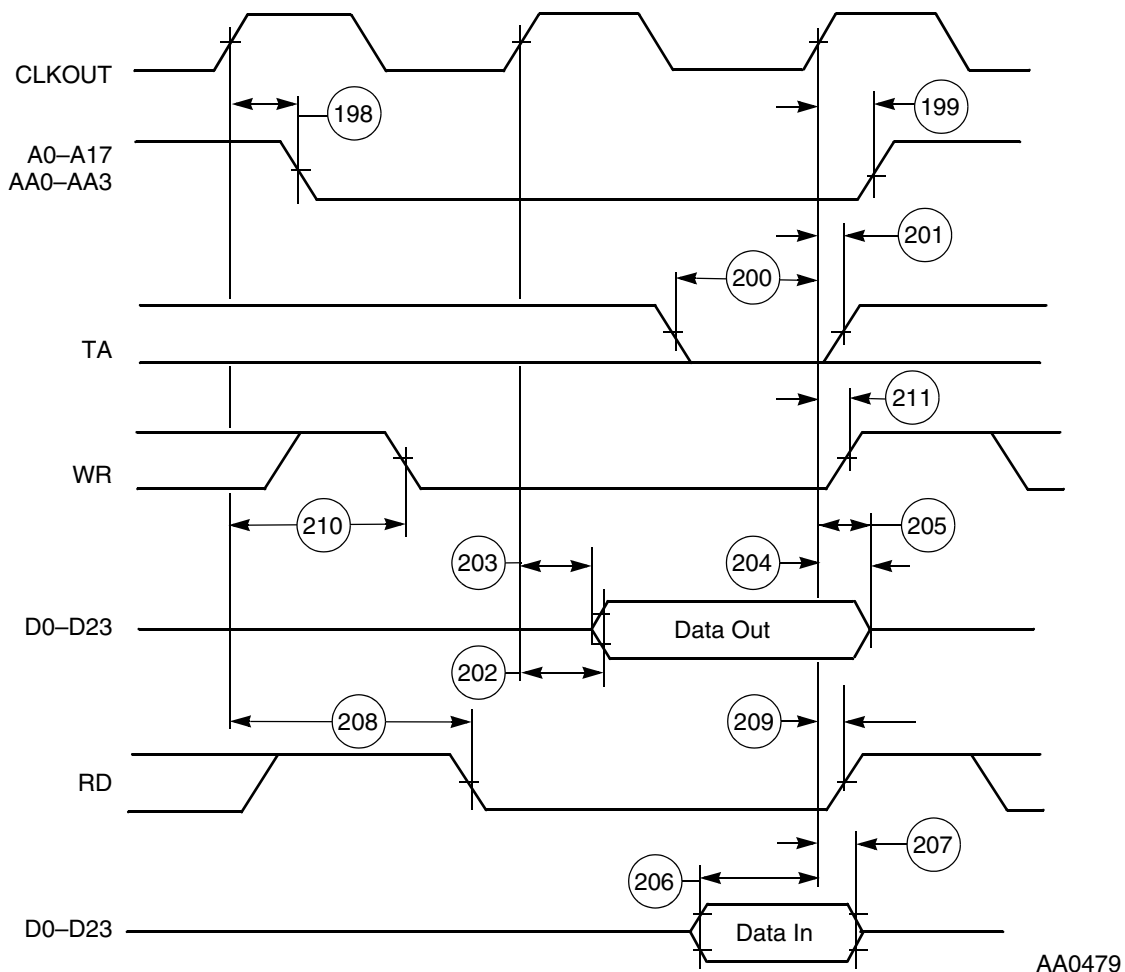

Figure 3-20 Synchronous Bus Timings SRAM 1 WS (BCR Controlled)

AA0479

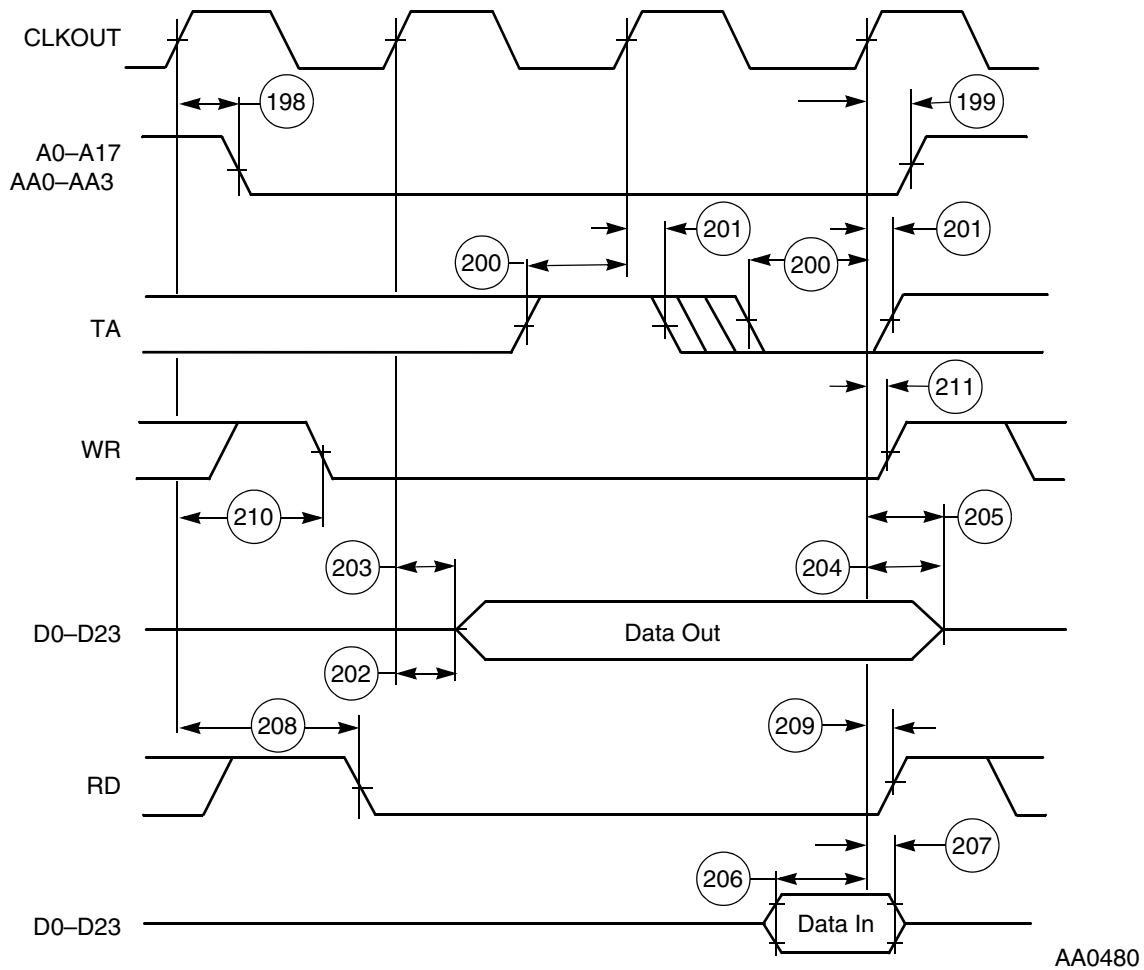

Figure 3-21 Synchronous Bus Timings SRAM 2 WS (\overline{TA} Controlled)

3.10.4 Arbitration Timings

Table 3-18 Arbitration Bus Timings¹

| No. | Characteristics | Expression | 100 MHz | | Unit |
|-----|-------------------------------------------------------------------|------------|---------|-----|------|
| | | | Min | Max | |
| 212 | CLKOUT high to \overline{BR} assertion/deassertion ² | | 1.0 | 4.0 | ns |
| 213 | \overline{BG} asserted/deasserted to CLKOUT high (setup) | | 4.0 | — | ns |
| 214 | CLKOUT high to \overline{BG} deasserted/asserted (hold) | | 0.0 | — | ns |
| 215 | \overline{BB} deassertion to CLKOUT high (input setup) | | 4.0 | — | ns |
| 216 | CLKOUT high to \overline{BB} assertion (input hold) | | 0.0 | — | ns |
| 217 | CLKOUT high to \overline{BB} assertion (output) | | 1.0 | 4.0 | ns |

Table 3-18 Arbitration Bus Timings¹ (continued)

| No. | Characteristics | Expression | 100 MHz | | Unit |
|-----|-----------------------------------------------------------------|-------------------------|---------|-----|------|
| | | | Min | Max | |
| 218 | CLKOUT high to \overline{BB} deassertion (output) | | 1.0 | 4.0 | ns |
| 219 | \overline{BB} high to \overline{BB} high impedance (output) | | — | 4.5 | ns |
| 220 | CLKOUT high to address and controls active | $0.25 \times T_C$ | 2.5 | — | ns |
| 221 | CLKOUT high to address and controls high impedance | $0.25 \times T_C$ | — | 2.5 | ns |
| 222 | CLKOUT high to AA active | $0.25 \times T_C$ | 2.5 | — | ns |
| 223 | CLKOUT high to AA deassertion | $0.25 \times T_C + 4.0$ | 3.2 | 6.5 | ns |
| 224 | CLKOUT high to AA high impedance | $0.75 \times T_C$ | — | 7.5 | ns |

¹ The asynchronous delays specified in the expressions are valid for DSP56362.

² T212 is valid for Address Trace mode when the ATE bit in the OMR is set. \overline{BR} is deasserted for internal accesses and asserted for external accesses.

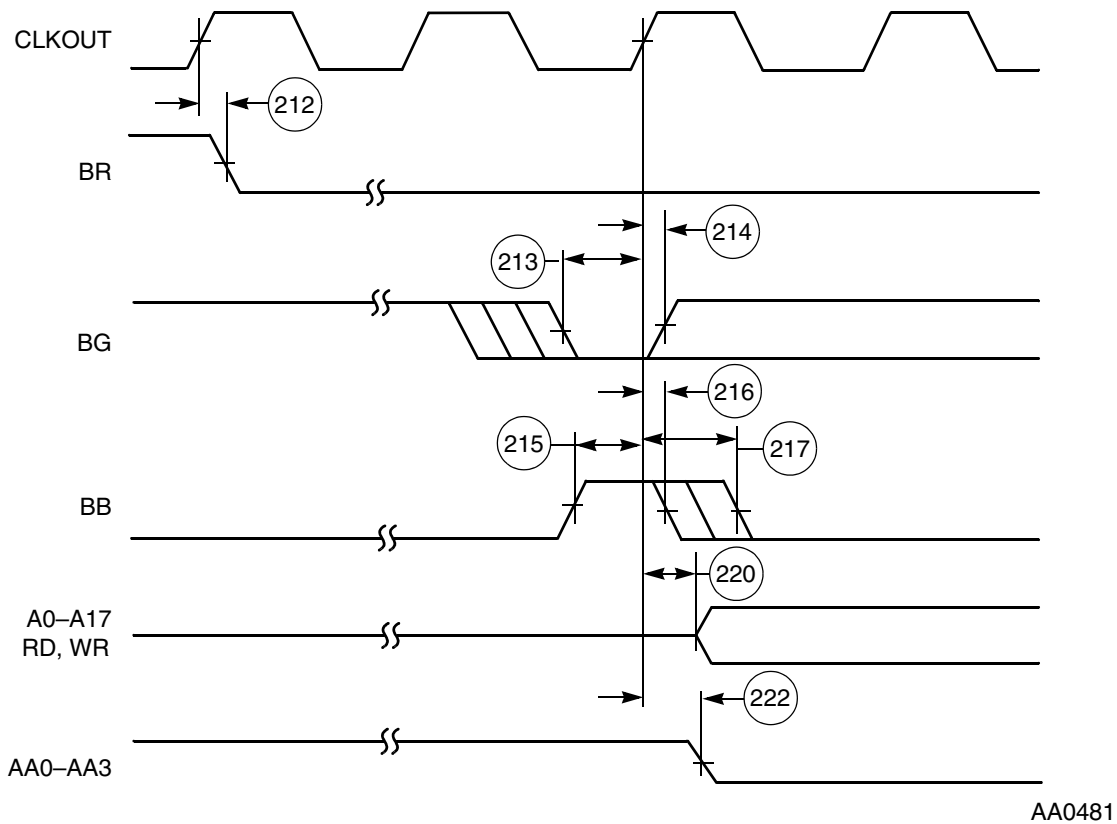
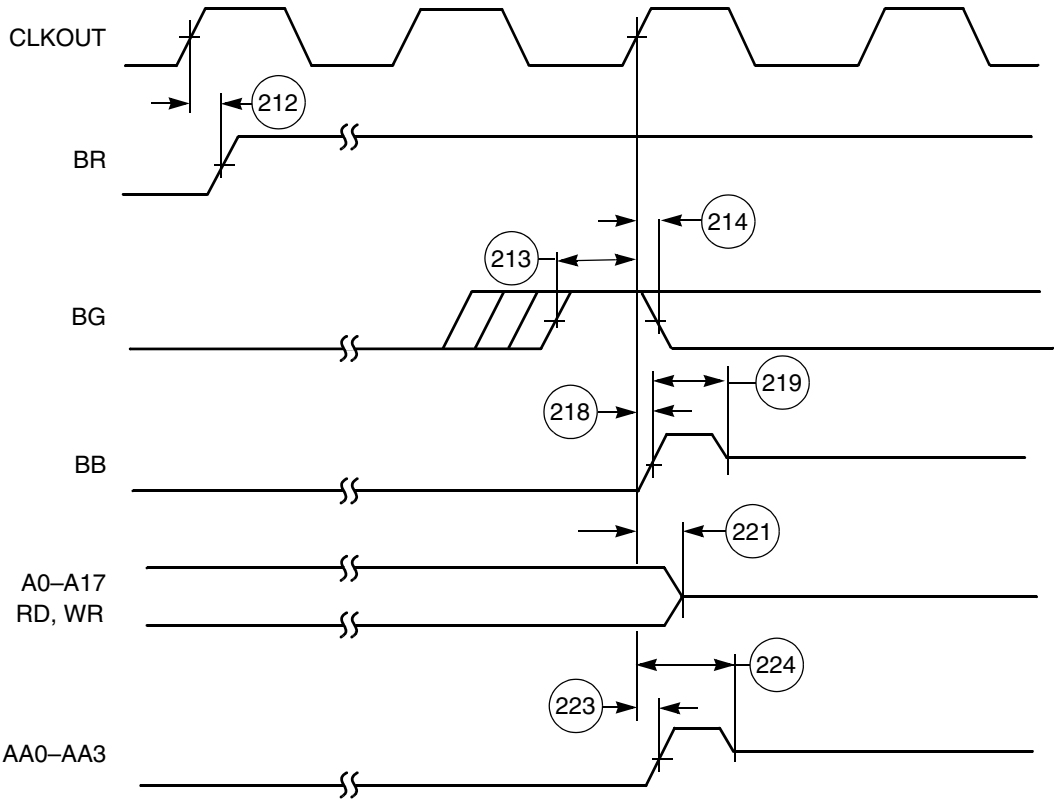

Figure 3-22 Bus Acquisition Timings



AA0482

Figure 3-23 Bus Release Timings Case 1 (BRT Bit in OMR Cleared)

External Memory Expansion Port (Port A)

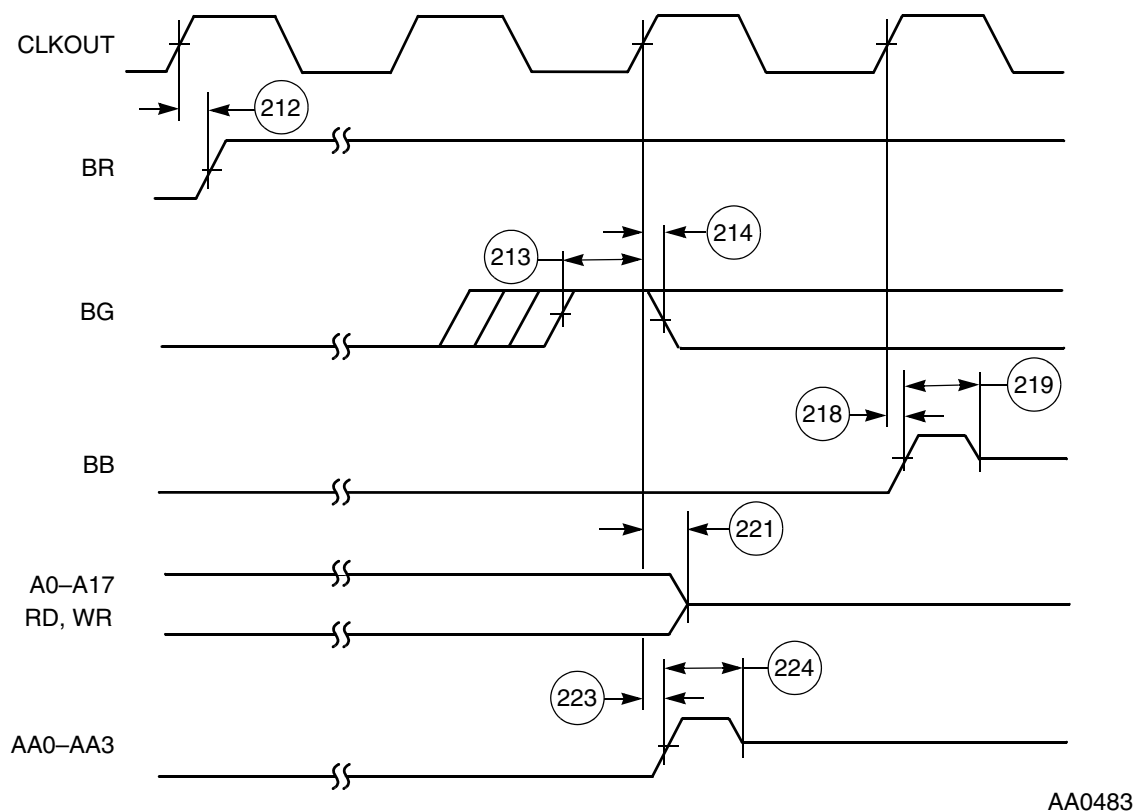

Figure 3-24 Bus Release Timings Case 2 (BRT Bit in OMR Set)

Table 3-19 Asynchronous Bus Arbitration timing

| No. | Characteristics | Expression | 100 MHz | | Unit |
|-----|---------------------------------------------|-----------------|---------|-----|------|
| | | | Min | Max | |
| 250 | BB assertion window from BG input negation. | $2.5 * T_c + 5$ | — | 20 | ns |
| 251 | Delay from BB assertion to BG assertion | $2 * T_c + 5$ | 20 | — | ns |

Notes:

1. Bit 13 in the OMR register must be set to enter Asynchronous Arbitration mode
2. At 100 MHz it is recommended to use Asynchronous Arbitration mode.
3. If Asynchronous Arbitration mode is active, none of the timings in [Table 3-19](#) is required.
4. In order to guarantee timings 250, and 251, it is recommended to assert BG inputs to different 56300 devices (on the same bus) in a non overlap manner as shown in [Figure 3-25](#).

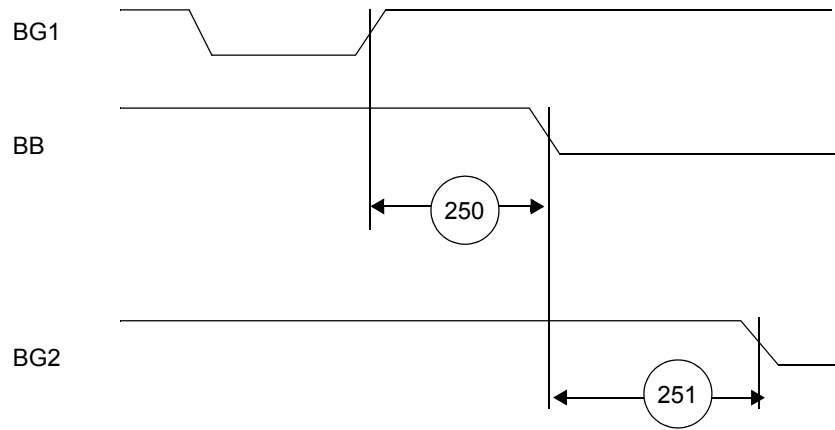

Figure 3-25 Asynchronous Bus Arbitration Timing

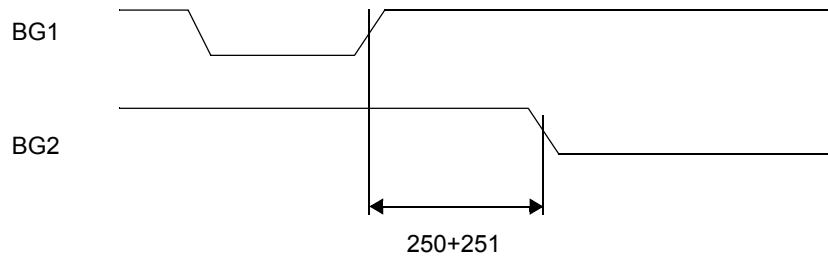

Figure 3-26 Asynchronous Bus Arbitration Timing

Background explanation for Asynchronous Bus Arbitration:

The asynchronous bus arbitration is enabled by internal synchronization circuits on \overline{BG} , and \overline{BB} inputs. These synchronization circuits add delay from the external signal until it is exposed to internal logic. As a result of this delay, a 56300 part may assume mastership and assert \overline{BB} , for some time after \overline{BG} is negated. This is the reason for timing 250.

Once \overline{BB} is asserted, there is a synchronization delay from \overline{BB} assertion to the time this assertion is exposed to other 56300 components which are potential masters on the same bus. If \overline{BG} input is asserted before that time, a situation of \overline{BG} asserted, and \overline{BB} negated, may cause another 56300 component to assume mastership at the same time. Therefore some non-overlap period between one \overline{BG} input active to another \overline{BG} input active, is required. Timing 251 ensures that such a situation is avoided.

3.11 Parallel Host Interface (HDI08) Timing

Table 3-20 Host Interface (HDI08) Timing^{1, 2}

| No. | Characteristics ³ | Expression | 100 MHz | | Unit |
|-----|------------------------------------------------------------------------------------------------------------------------------------------------------------------------------------------------------------------------------------------------------------------|------------------------|---------|------|------|
| | | | Min | Max | |
| 317 | Read data strobe assertion width ⁴ $\overline{\text{HACK}}$ read assertion width | $T_C + 9.9$ | 19.9 | — | ns |
| 318 | Read data strobe deassertion width ⁴ $\overline{\text{HACK}}$ read deassertion width | — | 9.9 | — | ns |
| 319 | Read data strobe deassertion width ⁴ after “Last Data Register” reads ^{5, 6} , or between two consecutive CVR, ICR, or ISR reads ⁷ $\overline{\text{HACK}}$ deassertion width after “Last Data Register” reads ^{5, 6} | $2.5 \times T_C + 6.6$ | 31.6 | — | ns |
| 320 | Write data strobe assertion width ⁸ $\overline{\text{HACK}}$ write assertion width | — | 13.2 | — | ns |
| 321 | Write data strobe deassertion width ⁸ $\overline{\text{HACK}}$ write deassertion width after ICR, CVR and “Last Data Register” writes ⁵ | $2.5 \times T_C + 6.6$ | 31.6 | — | ns |
| | after IVR writes, or after TXH:TXM writes (with HBE=0), or after TXL:TXM writes (with HBE=1) | | 16.5 | — | |
| 322 | $\overline{\text{HAS}}$ assertion width | — | 9.9 | — | ns |
| 323 | $\overline{\text{HAS}}$ deassertion to data strobe assertion ⁹ | — | 0.0 | — | ns |
| 324 | Host data input setup time before write data strobe deassertion ⁸ Host data input setup time before $\overline{\text{HACK}}$ write deassertion | — | 9.9 | — | ns |
| 325 | Host data input hold time after write data strobe deassertion ⁸ Host data input hold time after $\overline{\text{HACK}}$ write deassertion | — | 3.3 | — | ns |
| 326 | Read data strobe assertion to output data active from high impedance ⁴ $\overline{\text{HACK}}$ read assertion to output data active from high impedance | — | 3.3 | — | ns |
| 327 | Read data strobe assertion to output data valid ⁴ $\overline{\text{HACK}}$ read assertion to output data valid | — | — | 24.2 | ns |
| 328 | Read data strobe deassertion to output data high impedance ⁴ $\overline{\text{HACK}}$ read deassertion to output data high impedance | — | — | 9.9 | ns |
| 329 | Output data hold time after read data strobe deassertion ⁴ Output data hold time after $\overline{\text{HACK}}$ read deassertion | — | 3.3 | — | ns |
| 330 | $\overline{\text{HCS}}$ assertion to read data strobe deassertion ⁴ | $T_C + 9.9$ | 19.9 | — | ns |
| 331 | $\overline{\text{HCS}}$ assertion to write data strobe deassertion ⁸ | — | 9.9 | — | ns |
| 332 | $\overline{\text{HCS}}$ assertion to output data valid | — | — | 19.1 | ns |

Table 3-20 Host Interface (HDI08) Timing^{1, 2} (continued)

| No. | Characteristics ³ | Expression | 100 MHz | | Unit |
|-----|-------------------------------------------------------------------------------------------------------------------------------------------------------------------------------------------------------------------------------------------------------|--------------------------------------------------|---------------------|-------------|------|
| | | | Min | Max | |
| 333 | $\overline{\text{HCS}}$ hold time after data strobe deassertion ⁹ | — | 0.0 | — | ns |
| 334 | Address (AD7–AD0) setup time before $\overline{\text{HAS}}$ deassertion (HMUX=1) | — | 4.7 | — | ns |
| 335 | Address (AD7–AD0) hold time after $\overline{\text{HAS}}$ deassertion (HMUX=1) | — | 3.3 | — | ns |
| 336 | A10–A8 (HMUX=1), A2–A0 (HMUX=0), $\text{HR}/\overline{\text{W}}$ setup time before data strobe assertion ⁹ <ul style="list-style-type: none"> • Read • Write | — | 0 4.7 | — — | ns |
| 337 | A10–A8 (HMUX=1), A2–A0 (HMUX=0), $\text{HR}/\overline{\text{W}}$ hold time after data strobe deassertion ⁹ | — | 3.3 | — | ns |
| 338 | Delay from read data strobe deassertion to host request assertion for “Last Data Register” read ^{4, 5, 10} | T_C | 10 | — | ns |
| 339 | Delay from write data strobe deassertion to host request assertion for “Last Data Register” write ^{5, 8, 10} | $2 \times T_C$ | 20 | — | ns |
| 340 | Delay from data strobe assertion to host request deassertion for “Last Data Register” read or write ($\text{HROD} = 0$) ^{5, 9, 10} | — | — | 19.1 | ns |
| 341 | Delay from data strobe assertion to host request deassertion for “Last Data Register” read or write ($\text{HROD} = 1$, open drain Host Request) ^{5, 9, 10, 11} | — | — | 300.0 | ns |
| 342 | Delay from DMA $\overline{\text{HACK}}$ deassertion to HOREQ assertion <ul style="list-style-type: none"> • For “Last Data Register” read⁵ • For “Last Data Register” write⁵ • For other cases | $2 \times T_C + 19.1$ $1.5 \times T_C + 19.1$ | 39.1 34.1 0.0 | — — — | ns |
| 343 | Delay from DMA $\overline{\text{HACK}}$ assertion to HOREQ deassertion <ul style="list-style-type: none"> • $\text{HROD} = 0$⁵ | — | — | 20.2 | ns |
| 344 | Delay from DMA $\overline{\text{HACK}}$ assertion to HOREQ deassertion for “Last Data Register” read or write <ul style="list-style-type: none"> • $\text{HROD} = 1$, open drain Host Request^{5, 11} | — | — | 300.0 | ns |

¹ See **Host Port Usage Considerations** in the DSP56362 User Design Manual.

² In the timing diagrams below, the controls pins are drawn as active low. The pin polarity is programmable.

³ $V_{CC} = 3.3 \text{ V} \pm 0.16 \text{ V}$; $T_J = 0^\circ\text{C}$ to $+100^\circ\text{C}$, $C_L = 50 \text{ pF}$

⁴ The read data strobe is HRD in the dual data strobe mode and HDS in the single data strobe mode.

⁵ The “last data register” is the register at address \$7, which is the last location to be read or written in data transfers. This is RXL/TXL in the little endian mode ($\text{HBE} = 0$), or RXH/TXH in the big endian mode ($\text{HBE} = 1$).

⁶ This timing is applicable only if a read from the “last data register” is followed by a read from the RXL, RXM, or RXH registers without first polling RXDF or HREQ bits, or waiting for the assertion of the HOREQ signal.

⁷ This timing is applicable only if two consecutive reads from one of these registers are executed.

Parallel Host Interface (HDI08) Timing

- ⁸ The write data strobe is HWR in the dual data strobe mode and HDS in the single data strobe mode.
- ⁹ The data strobe is host read (HRD) or host write (HWR) in the dual data strobe mode and host data strobe (HDS) in the single data strobe mode.
- ¹⁰ The host request is HOREQ in the single host request mode and HRRQ and HTRQ in the double host request mode.
- ¹¹ In this calculation, the host request signal is pulled up by a 4.7 k Ω resistor in the open-drain mode.

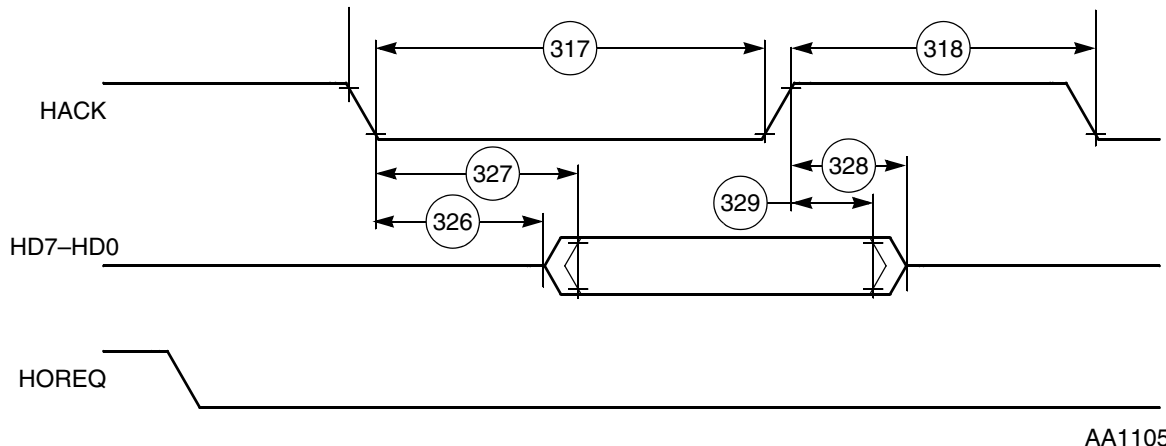

AA1105

Figure 3-27 Host Interrupt Vector Register (IVR) Read Timing Diagram

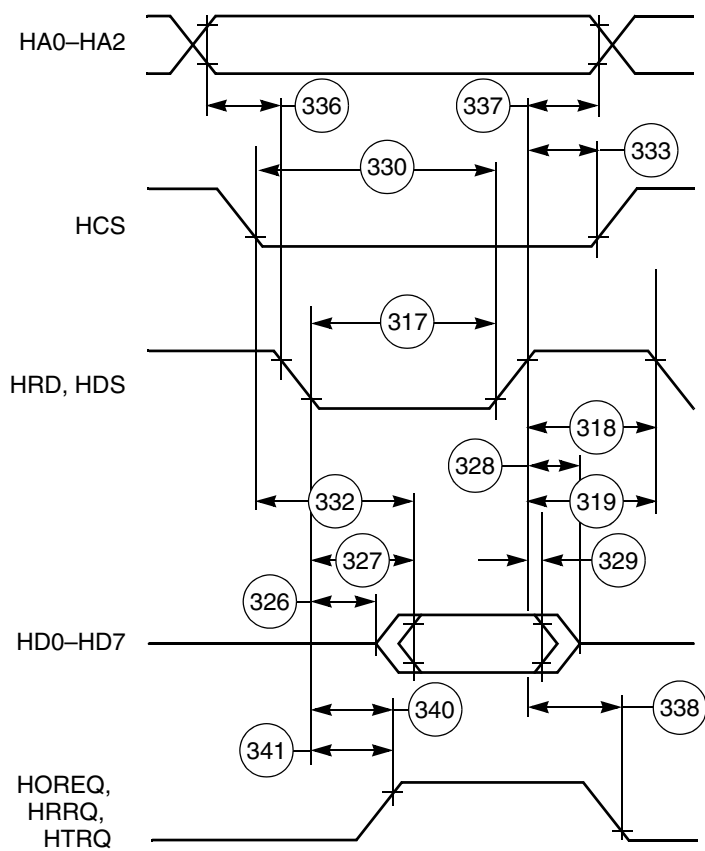

AA0484

Figure 3-28 Read Timing Diagram, Non-Multiplexed Bus

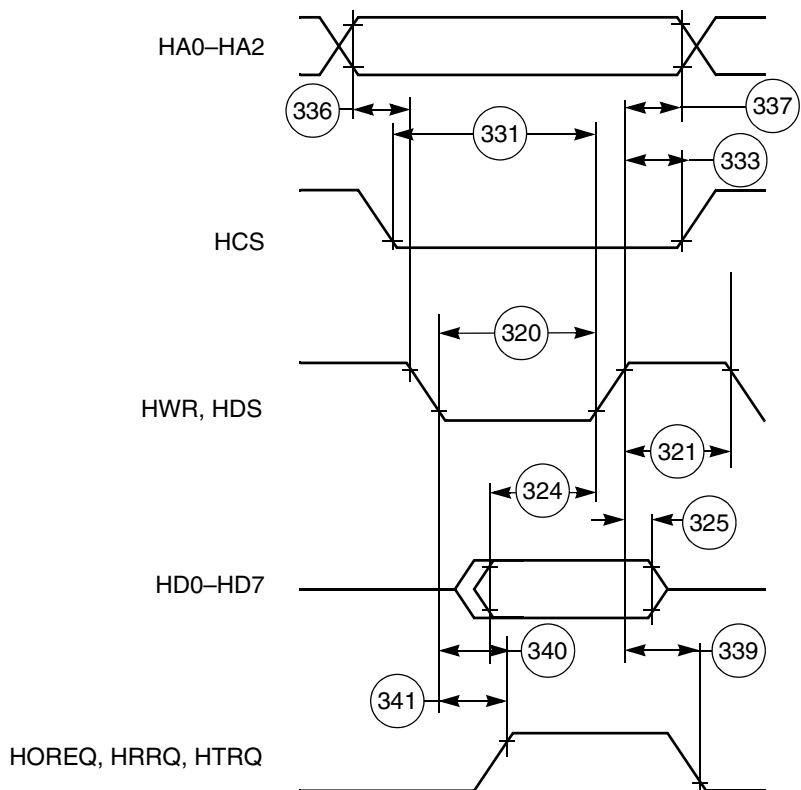

AA0485

Figure 3-29 Write Timing Diagram, Non-Multiplexed Bus

Parallel Host Interface (HDI08) Timing

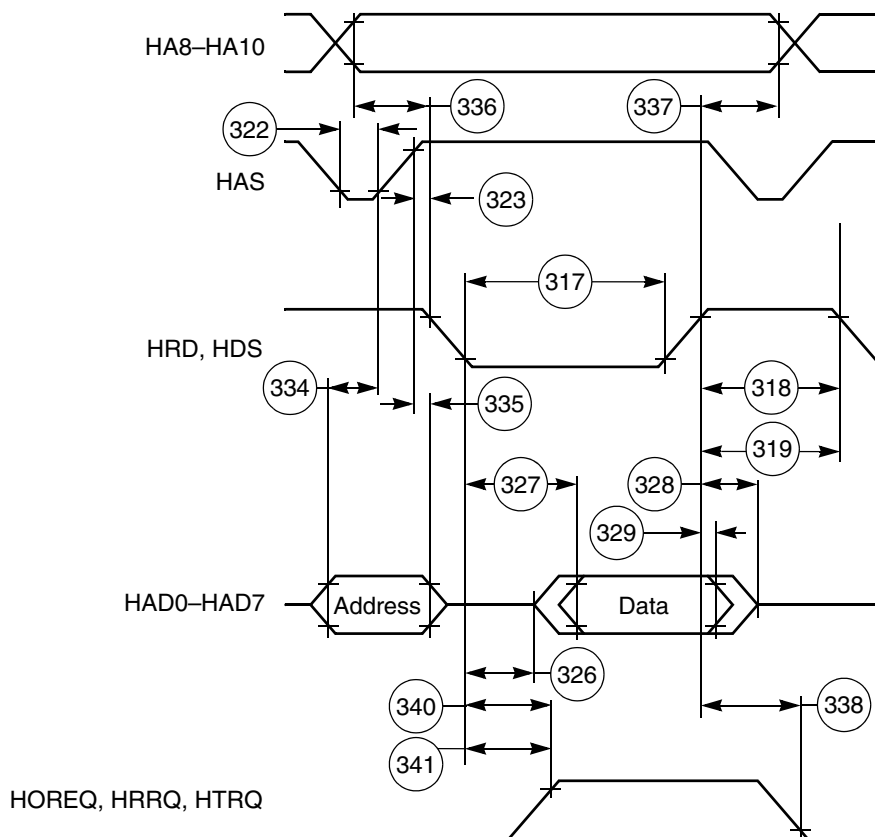

AA0486

Figure 3-30 Read Timing Diagram, Multiplexed Bus

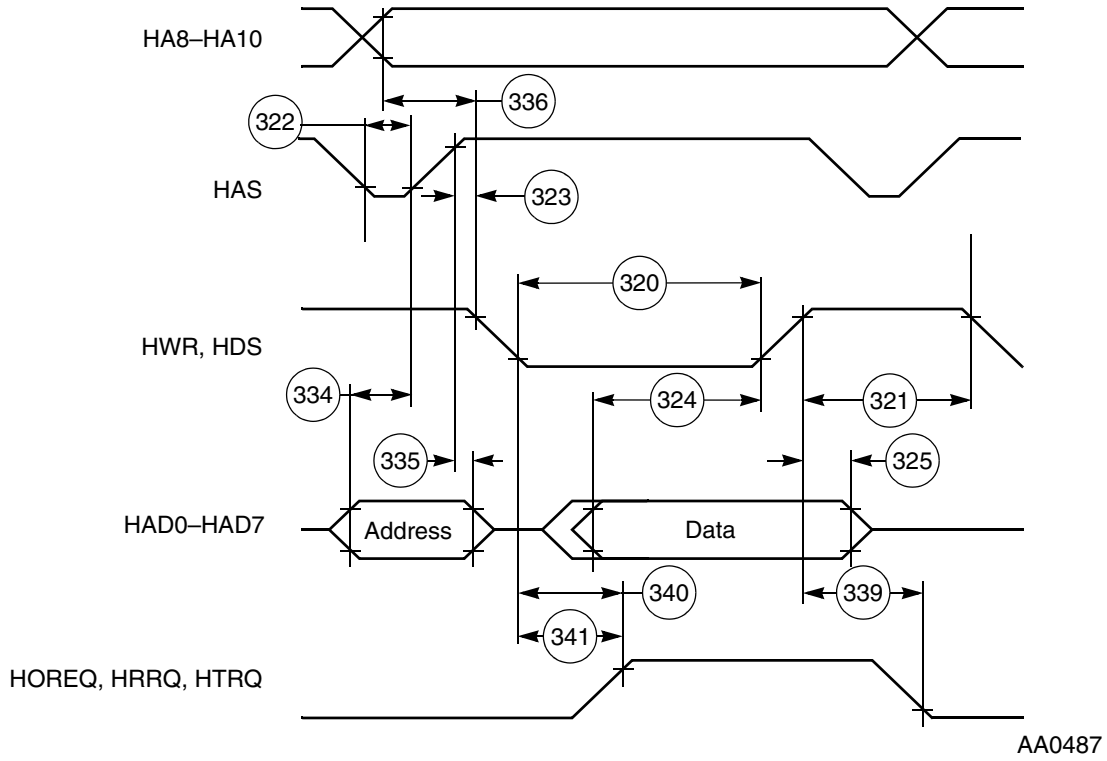

Figure 3-31 Write Timing Diagram, Multiplexed Bus

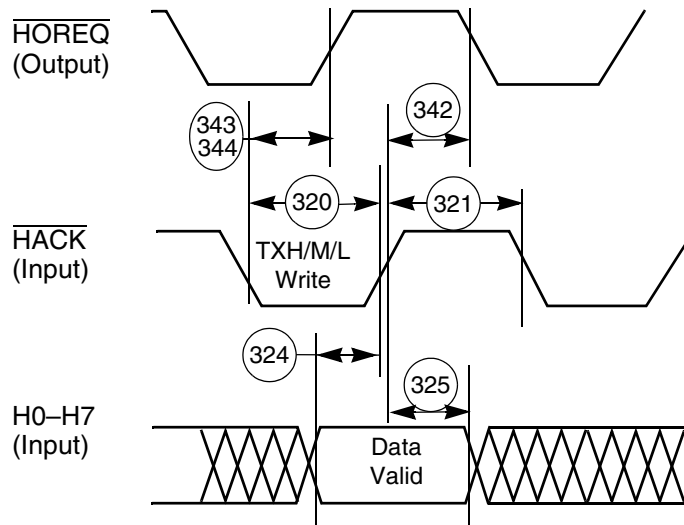

Figure 3-32 Host DMA Write Timing Diagram

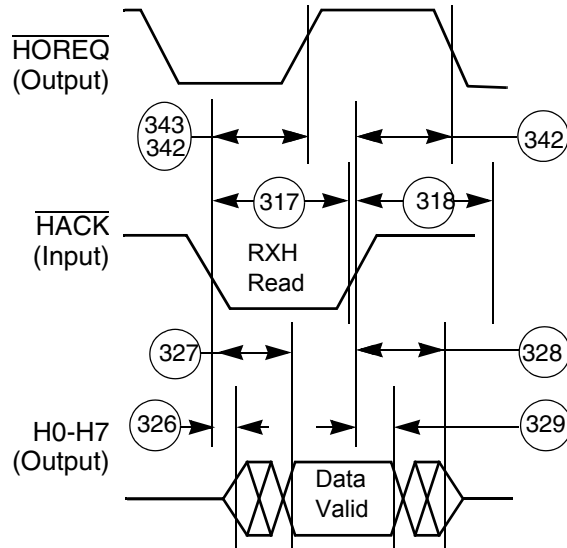

Figure 3-33 Host DMA Read Timing Diagram

3.12 Serial Host Interface SPI Protocol Timing

Table 3-21 Serial Host Interface SPI Protocol Timing

| No. | Characteristics | Mode | Filter Mode | Expression | 100MHz | | Unit |
|-----|------------------------------------------------|--------|----------------------------|-------------------------------------------------------------------------------------------|-------------------|----------------|------|
| | | | | | Min | Max | |
| 140 | Tolerable spike width on clock or data in | — | Bypassed Narrow Wide | — | — | 0 50 100 | ns |
| 141 | Minimum serial clock cycle = $t_{SPICC}(\min)$ | Master | Bypassed Narrow Wide | $6 \times T_C + 46$ $6 \times T_C + 152$ $6 \times T_C + 223$ | 106 212 283 | — — — | ns |
| 142 | Serial clock high period | Master | Bypassed Narrow Wide | $0.5 \times t_{SPICC} - 10$ $0.5 \times t_{SPICC} - 10$ $0.5 \times t_{SPICC} - 10$ | 43 96 131 | — — — | ns |
| | | Slave | Bypassed Narrow Wide | $2.5 \times T_C + 12$ $2.5 \times T_C + 102$ $2.5 \times T_C + 189$ | 37 127 214 | — — — | |
| 143 | Serial clock low period | Master | Bypassed Narrow Wide | $0.5 \times t_{SPICC} - 10$ $0.5 \times t_{SPICC} - 10$ $0.5 \times t_{SPICC} - 10$ | 43 96 131 | — — — | ns |
| | | Slave | Bypassed Narrow Wide | $2.5 \times T_C + 12$ $2.5 \times T_C + 102$ $2.5 \times T_C + 189$ | 37 127 214 | — — — | |

Table 3-21 Serial Host Interface SPI Protocol Timing (continued)

| No. | Characteristics | Mode | Filter Mode | Expression | 100MHz | | Unit |
|-----|------------------------------------------------------------------------------|------------------|-------------|-------------------------------|--------|------|------|
| | | | | | Min | Max | |
| 144 | Serial clock rise/fall time | Master | — | — | — | 10 | ns |
| | | Slave | — | — | — | 2000 | |
| 146 | \overline{SS} assertion to first SCK edge CPHA = 0 | Slave | Bypassed | $3.5 \times T_C + 15$ | 50 | — | ns |
| | | | Narrow | 0 | 0 | — | |
| | | | Wide | 0 | 0 | — | |
| | CPHA = 1 | Slave | Bypassed | 10 | 10 | — | |
| | | | Narrow | 0 | 0 | — | |
| | | | Wide | 0 | 0 | — | |
| 147 | Last SCK edge to \overline{SS} not asserted | slave | Bypassed | 12 | 12 | — | ns |
| | | | Narrow | 102 | 102 | — | |
| | | | Wide | 189 | 189 | — | |
| 148 | Data input valid to SCK edge (data input set-up time) | Master/ Slave | Bypassed | 0 | 0 | — | ns |
| | | | Narrow | $\text{MAX}\{(20 - T_C), 0\}$ | 10 | — | |
| | | | Wide | $\text{MAX}\{(40 - T_C), 0\}$ | 30 | — | |
| 149 | SCK last sampling edge to data input not valid | Master/ Slave | Bypassed | $2.5 \times T_C + 10$ | 35 | — | ns |
| | | | Narrow | $2.5 \times T_C + 30$ | 55 | — | |
| | | | Wide | $2.5 \times T_C + 50$ | 75 | — | |
| 150 | \overline{SS} assertion to data out active | Slave | — | 2 | 2 | — | ns |
| 151 | \overline{SS} deassertion to data high impedance | Slave | — | 9 | — | 9 | ns |
| 152 | SCK edge to data out valid (data out delay time) | Master/ Slave | Bypassed | $2 \times T_C + 33$ | — | 53 | ns |
| | | | Narrow | $2 \times T_C + 123$ | — | 143 | |
| | | | Wide | $2 \times T_C + 210$ | — | 230 | |
| 153 | SCK edge to data out not valid (data out hold time) | Master/ Slave | Bypassed | $T_C + 5$ | 15 | — | ns |
| | | | Narrow | $T_C + 55$ | 65 | — | |
| | | | Wide | $T_C + 106$ | 116 | — | |
| 154 | \overline{SS} assertion to data out valid (CPHA = 0) | Slave | — | $T_C + 33$ | — | 43 | ns |
| 157 | First SCK sampling edge to \overline{HREQ} output deassertion | Slave | Bypassed | $2.5 \times T_C + 30$ | — | 55 | ns |
| | | | Narrow | $2.5 \times T_C + 120$ | — | 145 | |
| | | | Wide | $2.5 \times T_C + 217$ | — | 242 | |
| 158 | Last SCK sampling edge to \overline{HREQ} output not deasserted (CPHA = 1) | Slave | Bypassed | $2.5 \times T_C + 30$ | 55 | — | ns |
| | | | Narrow | $2.5 \times T_C + 80$ | 105 | — | |
| | | | Wide | $2.5 \times T_C + 136$ | 161 | — | |

Table 3-21 Serial Host Interface SPI Protocol Timing (continued)

| No. | Characteristics | Mode | Filter Mode | Expression | 100MHz | | Unit |
|-----|-----------------------------------------------------------------------------------------------------------|--------|-------------|----------------------------------------------|--------|-----|------|
| | | | | | Min | Max | |
| 159 | \overline{SS} deassertion to \overline{HREQ} output not deasserted (CPHA = 0) | Slave | — | $2.5 \times T_C + 30$ | 55 | — | ns |
| 160 | \overline{SS} deassertion pulse width (CPHA = 0) | Slave | — | $T_C + 6$ | 16 | — | ns |
| 161 | \overline{HREQ} in assertion to first SCK edge | Master | Bypassed | $0.5 \times t_{SPICC} + 2.5 \times T_C + 43$ | 121 | — | ns |
| | | | Narrow | $0.5 \times t_{SPICC} + 2.5 \times T_C + 43$ | 174 | — | |
| | | | Wide | $0.5 \times t_{SPICC} + 2.5 \times T_C + 43$ | 209 | — | |
| 162 | \overline{HREQ} in deassertion to last SCK sampling edge (\overline{HREQ} in set-up time) (CPHA = 1) | Master | — | 0 | 0 | — | ns |
| 163 | First SCK edge to \overline{HREQ} in not asserted (\overline{HREQ} in hold time) | Master | — | 0 | 0 | — | ns |

Note: Periodically sampled, not 100% tested

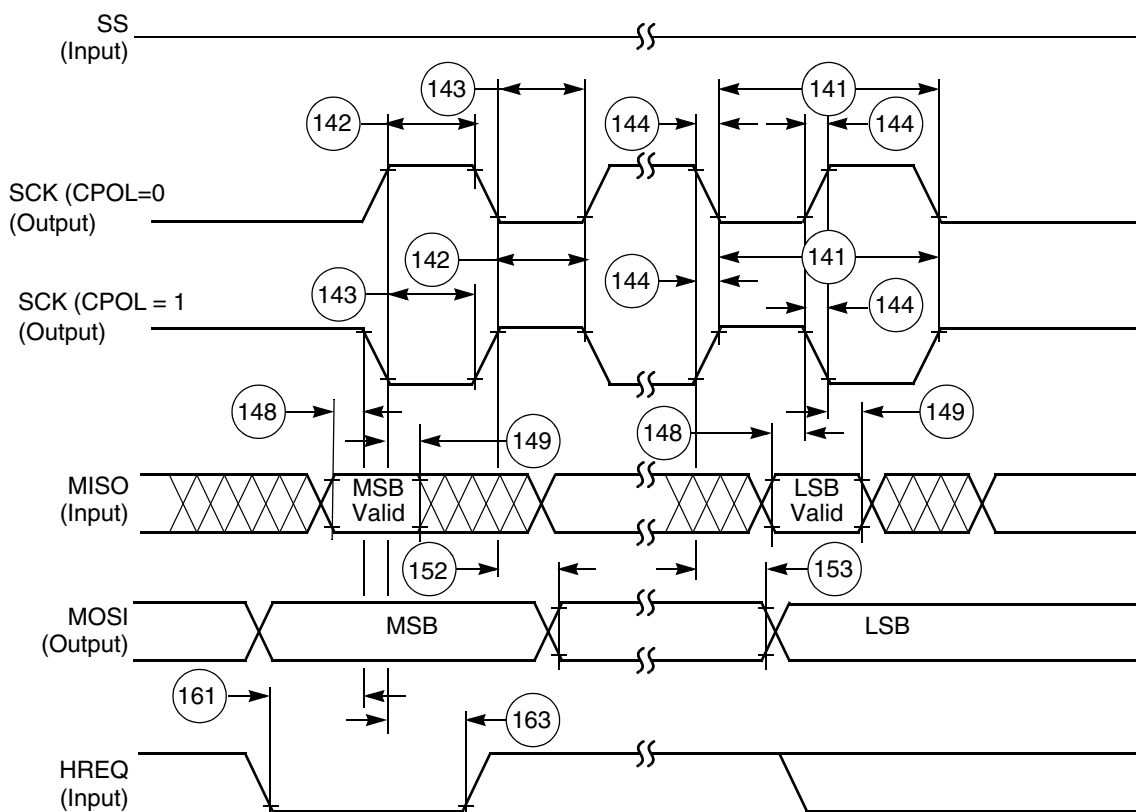

AA0271

Figure 3-34 SPI Master Timing (CPHA = 0)

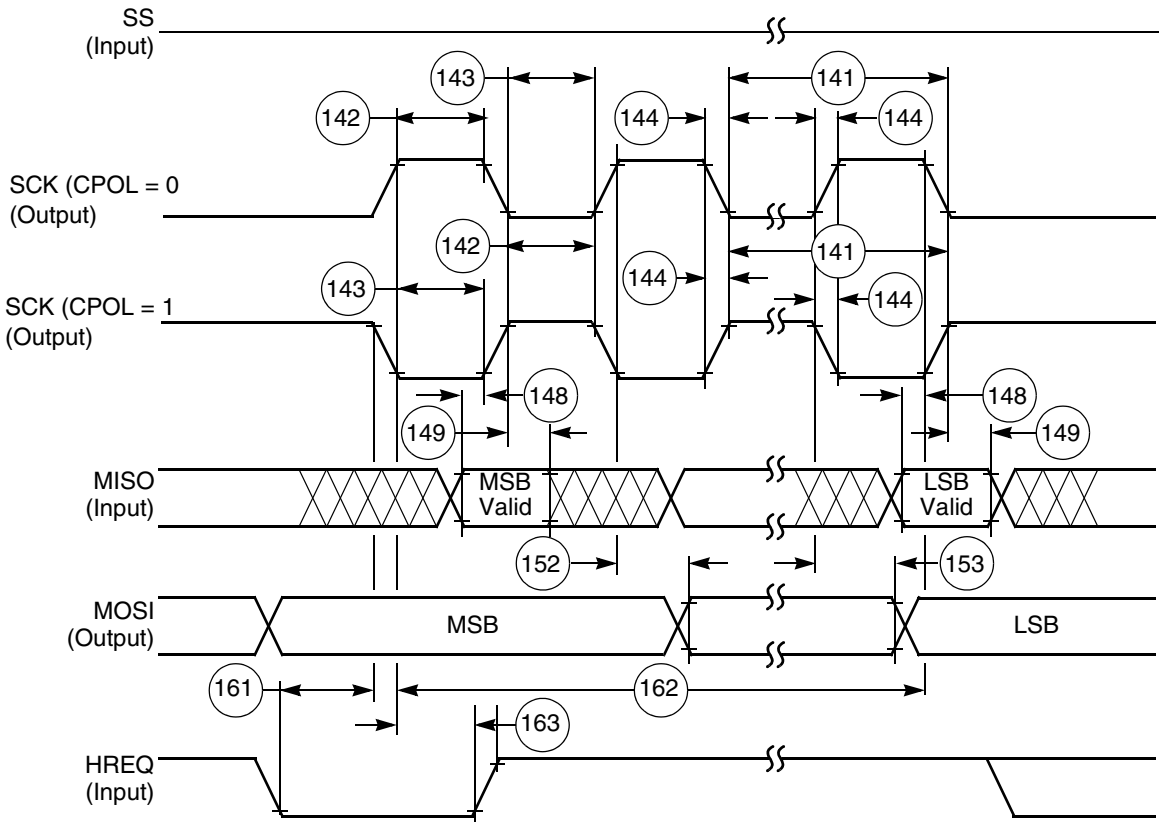

AA0272

Figure 3-35 SPI Slave Timing (CPHA = 0)

Serial Host Interface SPI Protocol Timing

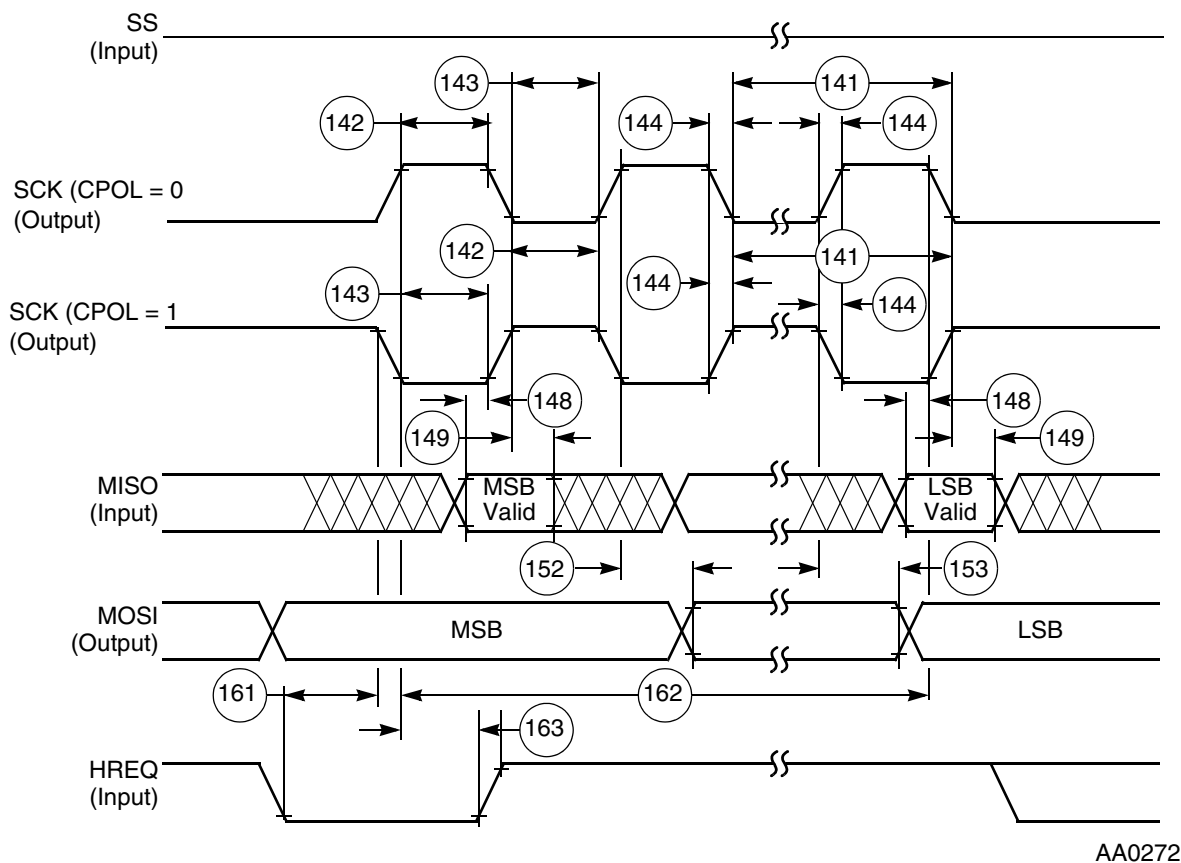

AA0272

Figure 3-36 SPI Master Timing (CPHA = 1)

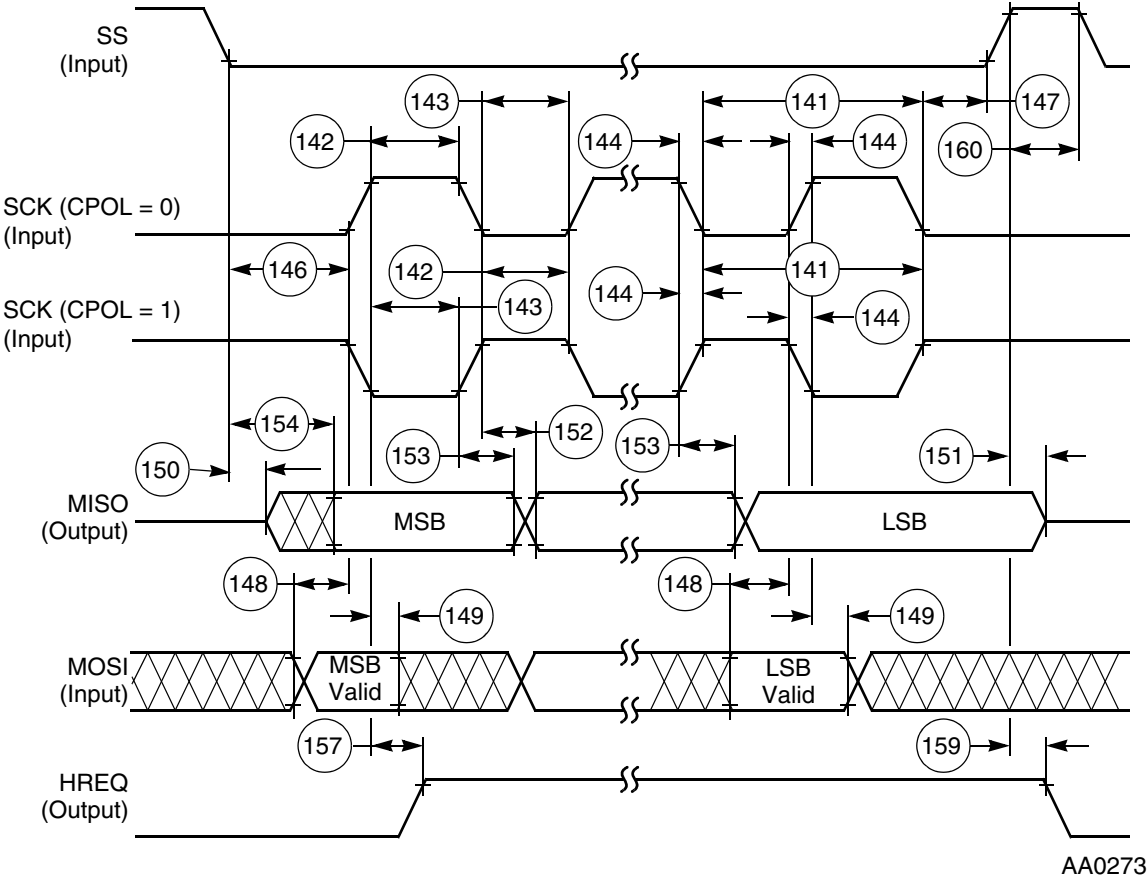
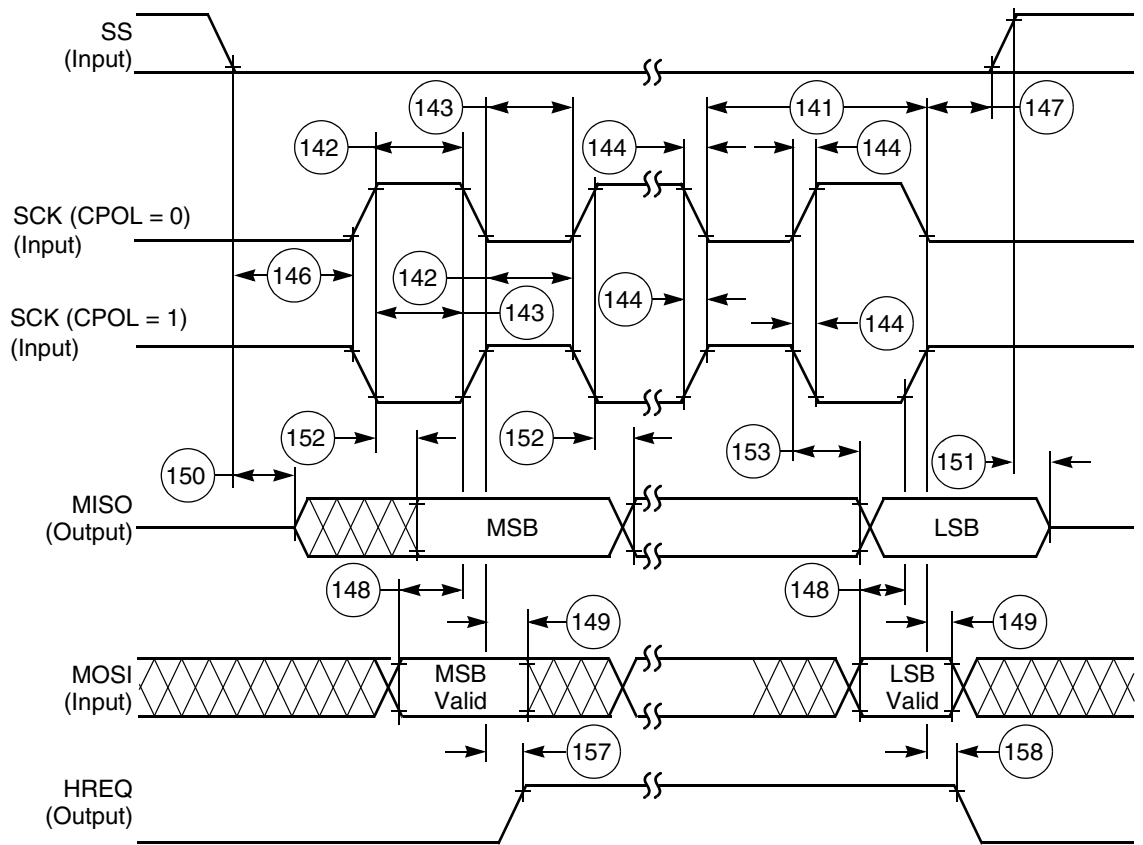

Figure 3-37 SPI Slave Timing (CPHA = 0)

AA0273



AA0274

Figure 3-38 SPI Slave Timing (CPHA = 1)

3.13 Serial Host Interface (SHI) I²C Protocol Timing

 Table 3-22 SHI I²C Protocol Timing

| Standard I ² C* | | | | | | | |
|----------------------------|-------------------------------------------------------------------------------------------------------------------------------------------------|------------------------------------------------------------------------------------------------------------|----------------------|------------------|---------------------------|------------------|------|
| No. | Characteristics | Symbol/ Expression | Standard | | Fast-Mode | | Unit |
| | | | Min | Max | Min | Max | |
| | Tolerable spike width on SCL or SDA Filters bypassed Narrow filters enabled Wide filters enabled | — | — | 0 50 100 | — | 0 50 100 | ns |
| 171 | SCL clock frequency | F _{SCL} | — | 100 | — | 400 | kHz |
| 172 | Bus free time | T _{BUF} | 4.7 | — | 1.3 | — | μs |
| 173 | Start condition set-up time | T _{SU;STA} | 4.7 | — | 0.6 | — | μs |
| 174 | Start condition hold time | T _{HD;STA} | 4.0 | — | 0.6 | — | μs |
| 175 | SCL low period | T _{LOW} | 4.7 | — | 1.3 | — | μs |
| 176 | SCL high period | T _{HIGH} | 4.0 | — | 1.3 | — | μs |
| 177 | SCL and SDA rise time | T _R | — | 1000 | 20 + 0.1 × C _b | 300 | ns |
| 178 | SCL and SDA fall time | T _F | — | 300 | 20 + 0.1 × C _b | 300 | ns |
| 179 | Data set-up time | T _{SU;DAT} | 250 | — | 100 | — | ns |
| 180 | Data hold time | T _{HD;DAT} | 0.0 | — | 0.0 | 0.9 | μs |
| 181 | Stop condition set-up time | T _{SU;STO} | 4.0 | — | 0.6 | — | μs |
| 182 | Capacitive load for each line | C _b | — | 400 | — | 400 | pF |
| 183 | DSP clock frequency Filters bypassed Narrow filters enabled Wide filters enabled | F _{DSP} | 10.6 11.8 13.1 | — | 28.5 39.7 61.0 | — | MHz |
| 184 | $\overline{\text{HREQ}}$ in deassertion to last SCL edge (HREQ in set-up time) | t _{SU;RQI} | 0.0 | — | 0.0 | — | ns |
| 186 | First SCL sampling edge to $\overline{\text{HREQ}}$ output deassertion Filters bypassed Narrow filters enabled Wide filters enabled | T _{NG;RQO} 2 × T _C + 30 2 × T _C + 120 2 × T _C + 208 | — — — | 50 140 228 | — — — | 50 140 228 | ns |

Table 3-22 SHI I²C Protocol Timing (continued)

| Standard I ² C* | | | | | | | |
|----------------------------|---------------------------------------------|-------------------------------------|----------|-----|-----------|-----|------|
| No. | Characteristics | Symbol/ Expression | Standard | | Fast-Mode | | Unit |
| | | | Min | Max | Min | Max | |
| 187 | Last SCL edge to HREQ output not deasserted | T _{AS;RQO} | | | | | ns |
| | Filters bypassed | 2 × T _C + 30 | 50 | — | 50 | — | |
| | Narrow filters enabled | 2 × T _C + 80 | 100 | — | 100 | — | |
| | Wide filters enabled | 2 × T _C + 135 | 155 | — | 155 | — | |
| 188 | HREQ in assertion to first SCL edge | T _{AS;RQI} | | | | | ns |
| | Filters bypassed | 0.5 × T _{I²CCP} | 4327 | — | 927 | — | |
| | Narrow filters enabled | — | 4282 | — | 882 | — | |
| | Wide filters enabled | 0.5 × T _C - 21 | 4238 | — | 838 | — | |

Note: R_P (min) = 1.5 k³/₄

3.13.1 Programming the Serial Clock

The programmed serial clock cycle, T_{I²CCP}, is specified by the value of the HDM[5:0] and HRS bits of the HCKR (SHI clock control register).

The expression for T_{I²CCP} is

$$T_{I^2CCP} = [T_C \times 2 \times (HDM[7:0] + 1) \times (7 \times (1 - HRS) + 1)]$$

where:

HRS is the prescaler rate select bit.

When HRS is cleared, the fixed divide-by-eight prescaler is operational.

When HRS is set, the prescaler is bypassed.

HDM[7:0] are the divider modulus select bits.

A divide ratio from 1 to 64 (HDM[5:0] = 0 to \$3F) may be selected.

In I²C mode, the user may select a value for the programmed serial clock cycle from

$$6 \times T_C \text{ (if HDM[5:0] = \$02 and HRS = 1)}$$

to

$$4096 \times T_C \text{ (if HDM[7:0] = \$FF and HRS = 0)}$$

The programmed serial clock cycle (T_{I²CCP}), SCL rise time (T_R), and the filters selected should be chosen in order to achieve the desired SCL frequency, as shown in [Table 3-23](#)

Table 3-23 SCL Serial Clock Cycle generated as Master

| | |
|------------------------|-------------------------------------------------|
| Filters bypassed | $T_{I^2C_{CCP}} + 2.5 \times T_C + 45ns + T_R$ |
| Narrow filters enabled | $T_{I^2C_{CCP}} + 2.5 \times T_C + 135ns + T_R$ |
| Wide filters enabled | $T_{I^2C_{CCP}} + 2.5 \times T_C + 223ns + T_R$ |

EXAMPLE:

For DSP clock frequency of 100 MHz (i.e. $T_C = 10ns$), operating in a standard-mode I²C environment ($F_{SCL} = 100$ KHz (i.e. $T_{SCL} = 10\mu s$), $T_R = 1000ns$), with filters bypassed

$$T_{I^2C_{CCP}} = 10\mu s - 2.5 \times 10ns - 45ns - 1000ns = 8930ns$$

Choosing HRS = 0 gives

$$HDM[7:0] = 8930ns / (2 \times 10ns \times 8) - 1 = 55.8$$

Thus the HDM[7:0] value should be programmed to \$38 (=56).

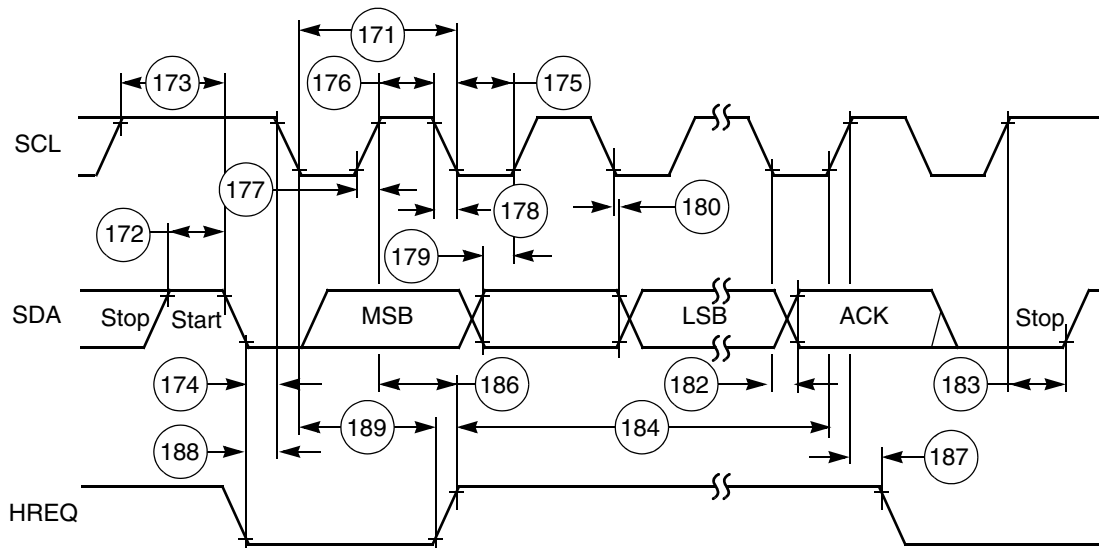

AA0275

Figure 3-39 I²C Timing

3.14 Enhanced Serial Audio Interface Timing

Table 3-24 Enhanced Serial Audio Interface Timing

| No. | Characteristics ^{1, 2, 3} | Symbol | Expression | 100 MHz | | Condition ⁴ | Unit |
|-----|----------------------------------------------------------------------|-------------|-------------------------------------------------------------------------------|------------------|--------|------------------------|------|
| | | | | Min | Max | | |
| 430 | Clock cycle ⁵ | t_{SSICC} | $4 \times T_C$ RXC: $3 \times T_C$ TXC: MAX [$3 \times T_C; t_{454}$] | 40.0 30 40 | — — | i ck x ck x ck | ns |
| 431 | Clock high period • For internal clock • For external clock | — | $2 \times T_C - 10.0$ $1.5 \times T_C$ | 10.0 15.0 | — — | | ns |
| 432 | Clock low period • For internal clock • For external clock | — | $2 \times T_C - 10.0$ $1.5 \times T_C$ | 10.0 15.0 | — — | | ns |
| 433 | RXC rising edge to FSR out (bl) high | — | — | — | 37.0 | x ck | ns |
| | | | | — | 22.0 | i ck a | |
| 434 | RXC rising edge to FSR out (bl) low | — | — | — | 37.0 | x ck | ns |
| | | | | — | 22.0 | i ck a | |
| 435 | RXC rising edge to FSR out (wr) high ⁶ | — | — | — | 39.0 | x ck | ns |
| | | | | — | 24.0 | i ck a | |
| 436 | RXC rising edge to FSR out (wr) low ⁶ | — | — | — | 39.0 | x ck | ns |
| | | | | — | 24.0 | i ck a | |
| 437 | RXC rising edge to FSR out (wl) high | — | — | — | 36.0 | x ck | ns |
| | | | | — | 21.0 | i ck a | |
| 438 | RXC rising edge to FSR out (wl) low | — | — | — | 37.0 | x ck | ns |
| | | | | — | 22.0 | i ck a | |
| 439 | Data in setup time before RXC (TXC in synchronous mode) falling edge | — | — | 0.0 19.0 | — — | x ck i ck | ns |
| 440 | Data in hold time after RXC falling edge | — | — | 5.0 | — | x ck | ns |
| | | | | 3.0 | — | i ck | |
| 441 | FSR input (bl, wr) high before RXC falling edge ⁶ | — | — | 23.0 | — | x ck | ns |
| | | | | 1.0 | — | i ck a | |
| 442 | FSR input (wl) high before RXC falling edge | — | — | 1.0 | — | x ck | ns |
| | | | | 23.0 | — | i ck a | |

Table 3-24 Enhanced Serial Audio Interface Timing (continued)

| No. | Characteristics ^{1, 2, 3} | Symbol | Expression | 100 MHz | | Condition ⁴ | Unit |
|-----|----------------------------------------------------------------------|--------|----------------------------|-------------|--------------|------------------------|------|
| | | | | Min | Max | | |
| 443 | FSR input hold time after RXC falling edge | — | — | 3.0 0.0 | — — | x ck i ck a | ns |
| 444 | Flags input setup before RXC falling edge | — | — | 0.0 19.0 | — — | x ck i ck s | ns |
| 445 | Flags input hold time after RXC falling edge | — | — | 6.0 0.0 | — — | x ck i ck s | ns |
| 446 | TXC rising edge to FST out (bl) high | — | — | — — | 29.0 15.0 | x ck i ck | ns |
| 447 | TXC rising edge to FST out (bl) low | — | — | — — | 31.0 17.0 | x ck i ck | ns |
| 448 | TXC rising edge to FST out (wr) high ⁶ | — | — | — — | 31.0 17.0 | x ck i ck | ns |
| 449 | TXC rising edge to FST out (wr) low ⁶ | — | — | — — | 33.0 19.0 | x ck i ck | ns |
| 450 | TXC rising edge to FST out (wl) high | — | — | — — | 30.0 16.0 | x ck i ck | ns |
| 451 | TXC rising edge to FST out (wl) low | — | — | — — | 31.0 17.0 | x ck i ck | ns |
| 452 | TXC rising edge to data out enable from high impedance | — | — | — — | 31.0 17.0 | x ck i ck | ns |
| 453 | TXC rising edge to transmitter drive enable assertion | — | — | — — | 34.0 20.0 | x ck i ck | ns |
| 454 | TXC rising edge to data out valid | — | $23 + 0.5 \times T_C$ 21.0 | — — | 28.0 21.0 | x ck i ck | ns |
| 455 | TXC rising edge to data out high impedance ⁷ | — | — | — — | 31.0 16.0 | x ck i ck | ns |
| 456 | TXC rising edge to transmitter drive enable deassertion ⁷ | — | — | — — | 34.0 20.0 | x ck i ck | ns |
| 457 | FST input (bl, wr) setup time before TXC falling edge ⁶ | — | — | 2.0 21.0 | — — | x ck i ck | ns |

Table 3-24 Enhanced Serial Audio Interface Timing (continued)

| No. | Characteristics ^{1, 2, 3} | Symbol | Expression | 100 MHz | | Condition ⁴ | Unit |
|-----|-------------------------------------------------------|--------|------------|-------------|--------------|------------------------|------|
| | | | | Min | Max | | |
| 458 | FST input (wl) to data out enable from high impedance | — | — | — | 27.0 | — | ns |
| 459 | FST input (wl) to transmitter drive enable assertion | — | — | — | 31.0 | — | ns |
| 460 | FST input (wl) setup time before TXC falling edge | — | — | 2.0 21.0 | — — | x ck i ck | ns |
| 461 | FST input hold time after TXC falling edge | — | — | 4.0 0.0 | — — | x ck i ck | ns |
| 462 | Flag output valid after TXC rising edge | — | — | — — | 32.0 18.0 | x ck i ck | ns |
| 463 | HCKR/HCKT clock cycle | — | — | 40.0 | — | | ns |
| 464 | HCKT input rising edge to TXC output | — | — | — | 27.5 | | ns |
| 465 | HCKR input rising edge to RXC output | — | — | — | 27.5 | | ns |

¹ V_{CC} = 3.3 V ± 0.16 V; T_J = 0°C to +100°C, C_L = 50 pF

² i ck = internal clock

x ck = external clock

i ck a = internal clock, asynchronous mode (asynchronous implies that TXC and RXC are two different clocks)

i ck s = internal clock, synchronous mode (synchronous implies that TXC and RXC are the same clock)

³ bl = bit length

wl = word length

wr = word length relative

⁴ TXC(SCKT pin) = transmit clock

RXC(SCKR pin) = receive clock

FST(FST pin) = transmit frame sync

FSR(FSR pin) = receive frame sync

HCKT(HCKT pin) = transmit high frequency clock

HCKR(HCKR pin) = receive high frequency clock

⁵ For the internal clock, the clock cycle at the pin is defined by l_{cy}c and the ESAI control registers.

⁶ The word-relative frame sync signal waveform relative to the clock operates in the same manner as the bit-length frame sync signal waveform, but spreads from one serial clock before first bit clock (same as bit length frame sync signal), until the one before last bit clock of the first word in frame.

⁷ Periodically sampled and not 100% tested.

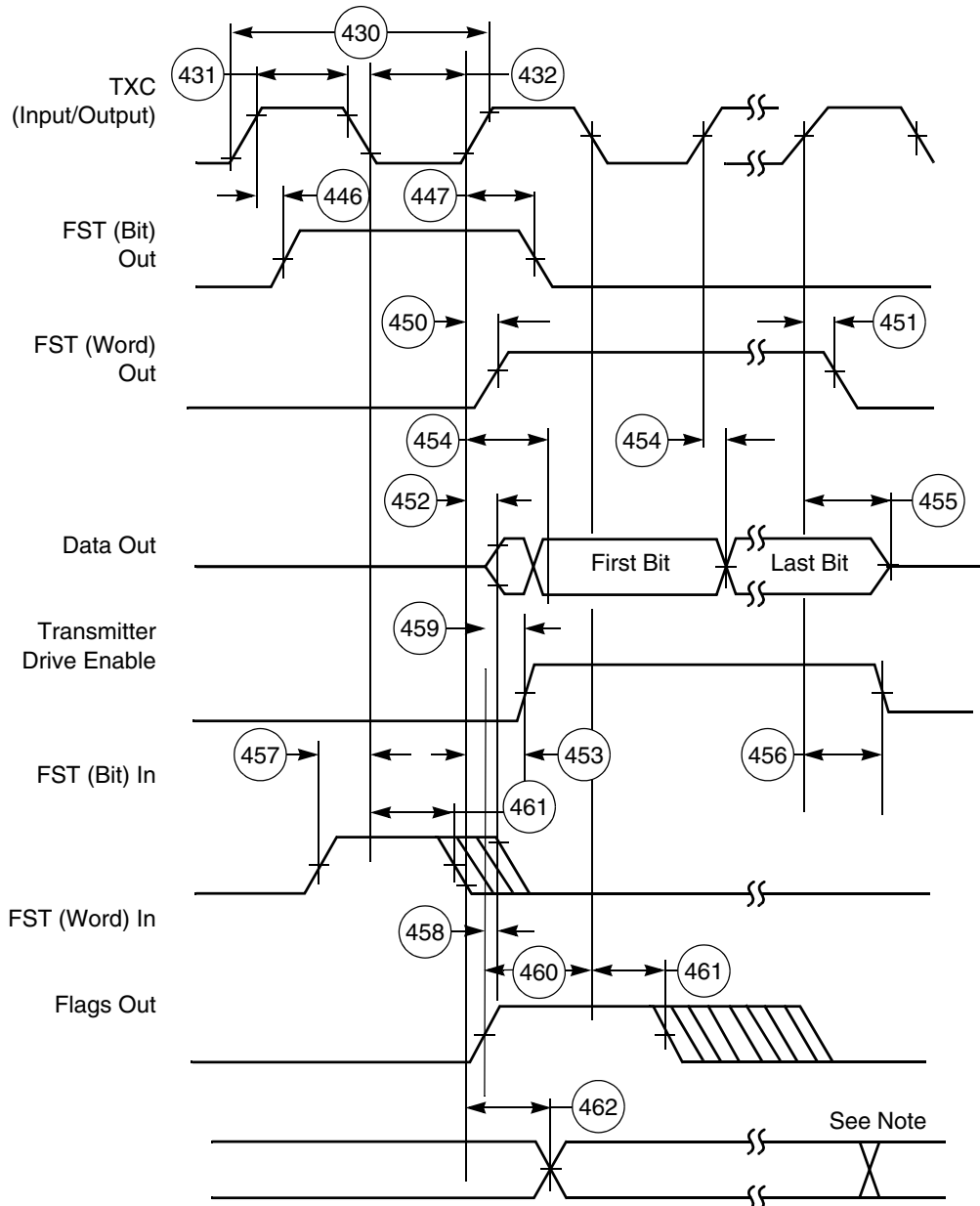

Note: In network mode, output flag transitions can occur at the start of each time slot within the frame. In normal mode, the output flag state is asserted for the entire frame period.

AA0490

Figure 3-40 ESAI Transmitter Timing

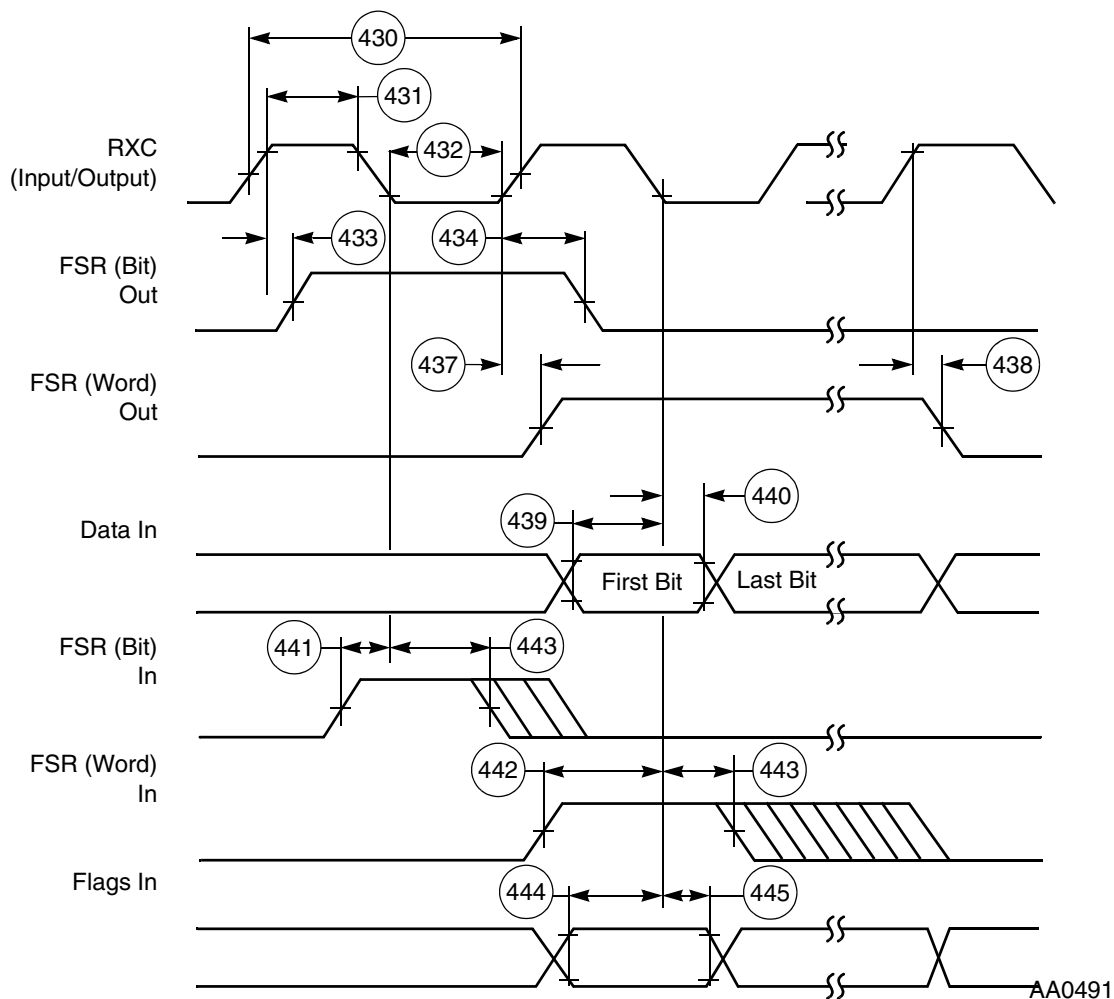

Figure 3-41 ESAI Receiver Timing

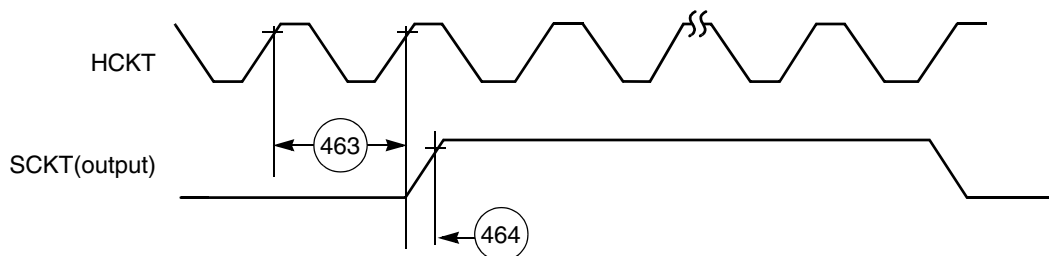

Figure 3-42 ESAI HCKT Timing

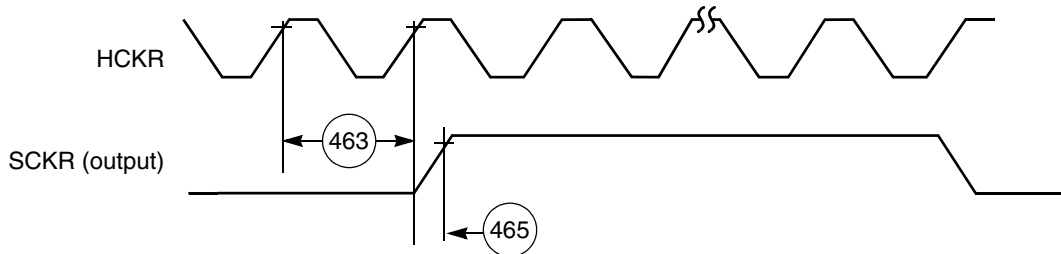

Figure 3-43 ESAI HCKR Timing

3.15 Digital Audio Transmitter Timing

Table 3-25 Digital Audio Transmitter Timing

| No. | Characteristic | Expression | 100 MHz | | Unit |
|-----|------------------------------|------------------|---------|-----|------|
| | | | Min | Max | |
| | ACI frequency ¹ | — | — | 50 | MHz |
| 220 | ACI period | $2 \times T_C$ | 20 | — | ns |
| 221 | ACI high duration | $0.5 \times T_C$ | 5 | — | ns |
| 222 | ACI low duration | $0.5 \times T_C$ | 5 | — | ns |
| 223 | ACI rising edge to ADO valid | $1.5 \times T_C$ | — | 15 | ns |

¹ In order to assure proper operation of the DAX, the ACI frequency should be less than 1/2 of the DSP56362 internal clock frequency. For example, if the DSP56362 is running at 100 MHz internally, the ACI frequency should be less than 50 MHz.

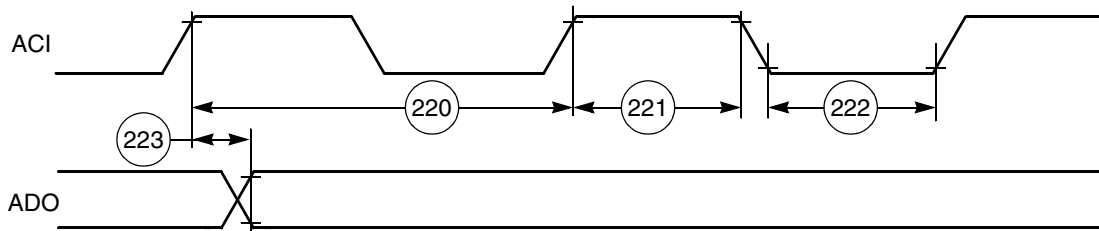

AA1280

Figure 3-44 Digital Audio Transmitter Timing

3.16 Timer Timing

Table 3-26 Timer Timing¹

| No. | Characteristics | Expression | 100 MHz | | Unit |
|-----|------------------------------------------------------------------------------------------------------------------------------------------------------|---------------------------------------------------|----------|-----------|------|
| | | | Min | Max | |
| 480 | TIO Low | $2 \times T_C + 2.0$ | 22.0 | — | ns |
| 481 | TIO High | $2 \times T_C + 2.0$ | 22.0 | — | ns |
| 482 | Timer setup time from TIO (Input) assertion to CLKOUT rising edge | | 9.0 | 10.0 | ns |
| 483 | Synchronous timer delay time from CLKOUT rising edge to the external memory access address out valid caused by first interrupt instruction execution | $10.25 \times T_C + 1.0$ | 103.5 | — | ns |
| 484 | CLKOUT rising edge to TIO (Output) assertion | | | | ns |
| | <ul style="list-style-type: none"> • Minimum • Maximum | $0.5 \times T_C + 3.5$ $0.5 \times T_C + 19.8$ | 8.5 — | — 24.8 | |
| 485 | CLKOUT rising edge to TIO (Output) deassertion | | | | ns |
| | <ul style="list-style-type: none"> • Minimum • Maximum | $0.5 \times T_C + 3.5$ $0.5 \times T_C + 19.0$ | 8.5 — | — 24.8 | |

¹ $V_{CC} = 3.3 \text{ V} \pm 0.16 \text{ V}$; $T_J = 0^\circ\text{C}$ to $+100^\circ\text{C}$, $C_L = 50 \text{ pF}$

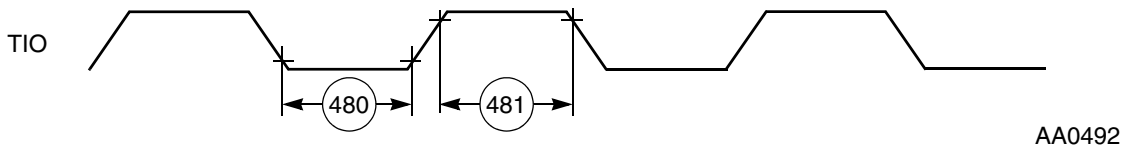

Figure 3-45 TIO Timer Event Input Restrictions

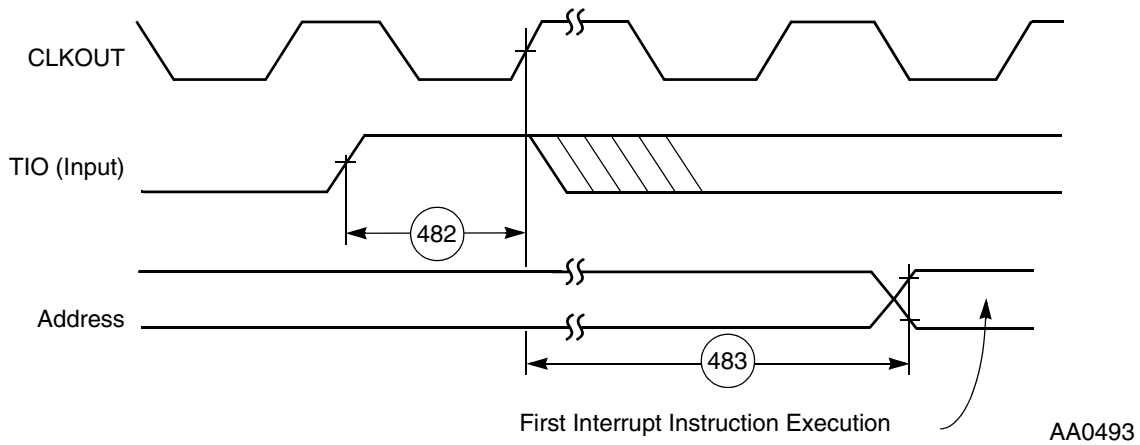

Figure 3-46 Timer Interrupt Generation

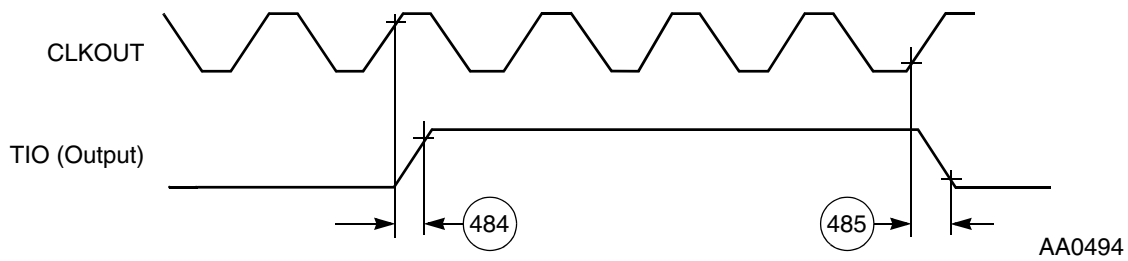

Figure 3-47 External Pulse Generation

3.17 GPIO Timing

Table 3-27 GPIO Timing¹

| No. | Characteristics | Expression | 100 MHz | | Unit |
|-----|--------------------------------------------------------|-------------------|---------|------|------|
| | | | Min | Max | |
| 490 | CLKOUT edge to GPIO out valid (GPIO out delay time) | | — | 31.0 | ns |
| 491 | CLKOUT edge to GPIO out not valid (GPIO out hold time) | | 3.0 | — | ns |
| 492 | GPIO In valid to CLKOUT edge (GPIO in set-up time) | | 12.0 | — | ns |
| 493 | CLKOUT edge to GPIO in not valid (GPIO in hold time) | | 0.0 | — | ns |
| 494 | Fetch to CLKOUT edge before GPIO change | $6.75 \times T_C$ | 67.5 | — | ns |
| 495 | GPIO out rise time | — | — | 13 | ns |
| 496 | GPIO out fall time | — | — | 13 | ns |

¹ $V_{CC} = 3.3 \text{ V} \pm 0.16 \text{ V}$; $T_J = 0^\circ\text{C to } +100^\circ\text{C}$, $C_L = 50 \text{ pF}$

JTAG Timing

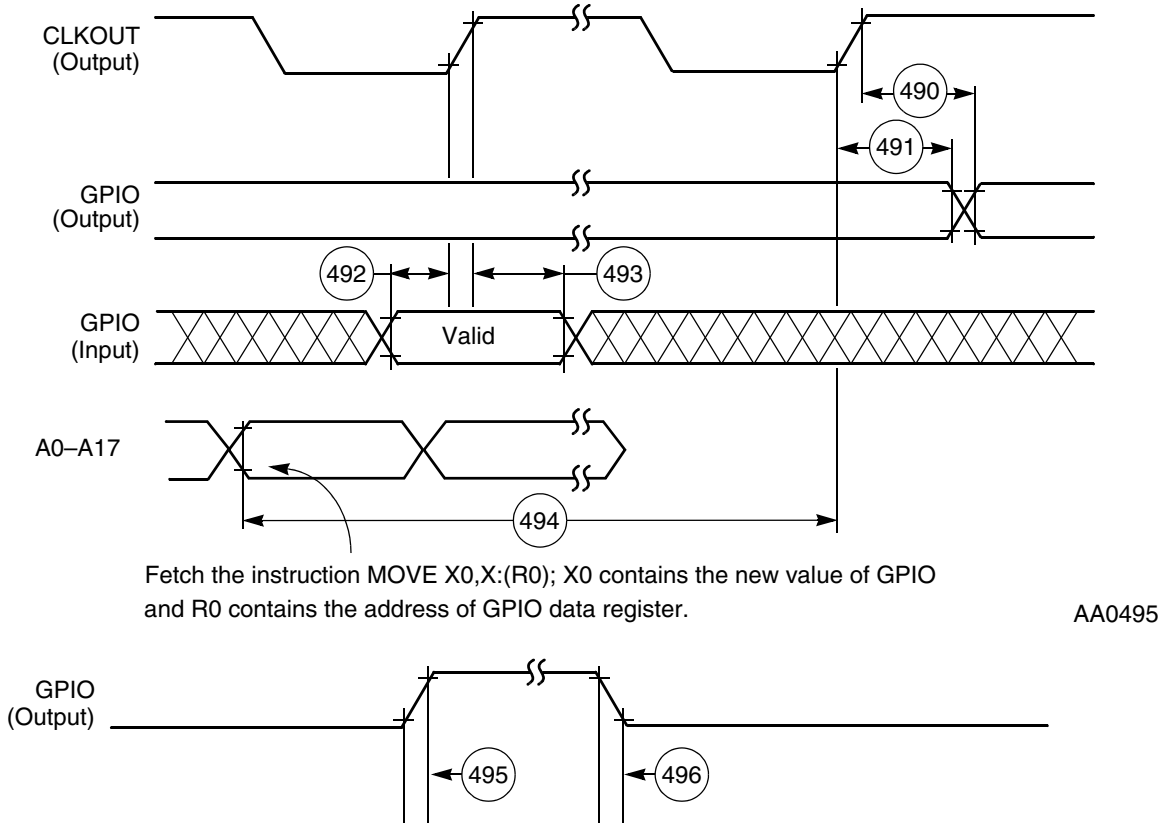

Figure 3-48 GPIO Timing

3.18 JTAG Timing

Table 3-28 JTAG Timing^{1, 2}

| No. | Characteristics | All Frequencies | | Unit |
|-----|-------------------------------------------------------------------|-----------------|------|------|
| | | Min | Max | |
| 500 | TCK frequency of operation ($1/(T_C \times 3)$; maximum 22 MHz) | 0.0 | 22.0 | MHz |
| 501 | TCK cycle time in Crystal mode | 45.0 | — | ns |
| 502 | TCK clock pulse width measured at 1.5 V | 20.0 | — | ns |
| 503 | TCK rise and fall times | 0.0 | 3.0 | ns |
| 504 | Boundary scan input data setup time | 5.0 | — | ns |
| 505 | Boundary scan input data hold time | 24.0 | — | ns |
| 506 | TCK low to output data valid | 0.0 | 40.0 | ns |
| 507 | TCK low to output high impedance | 0.0 | 40.0 | ns |

Table 3-28 JTAG Timing^{1, 2} (continued)

| No. | Characteristics | All Frequencies | | Unit |
|-----|------------------------------------------------|-----------------|------|------|
| | | Min | Max | |
| 508 | TMS, TDI data setup time | 5.0 | — | ns |
| 509 | TMS, TDI data hold time | 25.0 | — | ns |
| 510 | TCK low to TDO data valid | 0.0 | 44.0 | ns |
| 511 | TCK low to TDO high impedance | 0.0 | 44.0 | ns |
| 512 | $\overline{\text{TRST}}$ assert time | 100.0 | — | ns |
| 513 | $\overline{\text{TRST}}$ setup time to TCK low | 40.0 | — | ns |

¹ $V_{CC} = 3.3 \text{ V} \pm 0.16\text{V}$; $T_J = 0^\circ\text{C}$ to $+100^\circ\text{C}$, $C_L = 50 \text{ pF}$

² All timings apply to OnCE module data transfers because it uses the JTAG port as an interface.

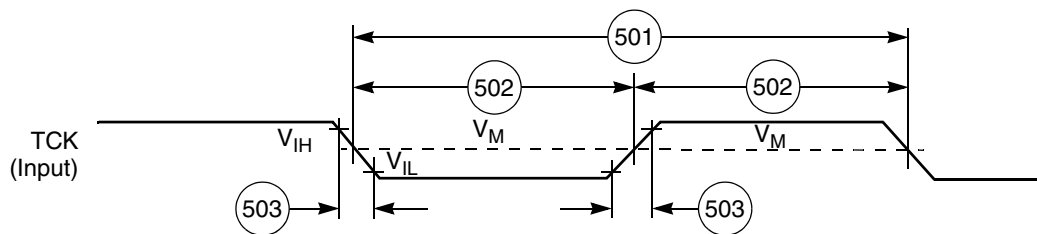

AA0496

Figure 3-49 Test Clock Input Timing Diagram

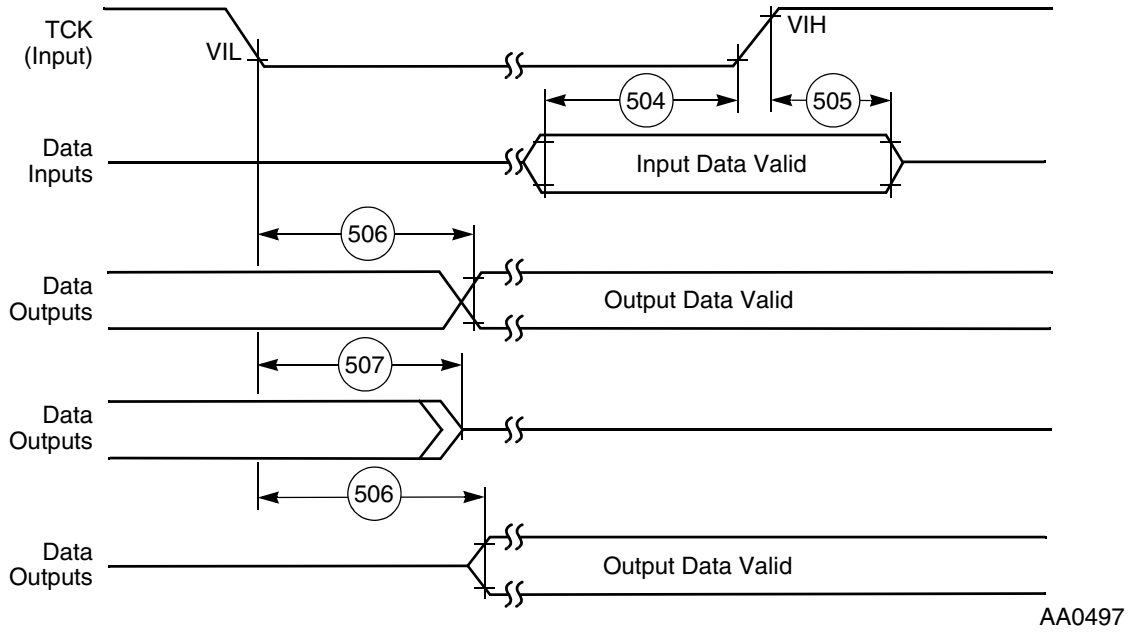

Figure 3-50 Boundary Scan (JTAG) Timing Diagram

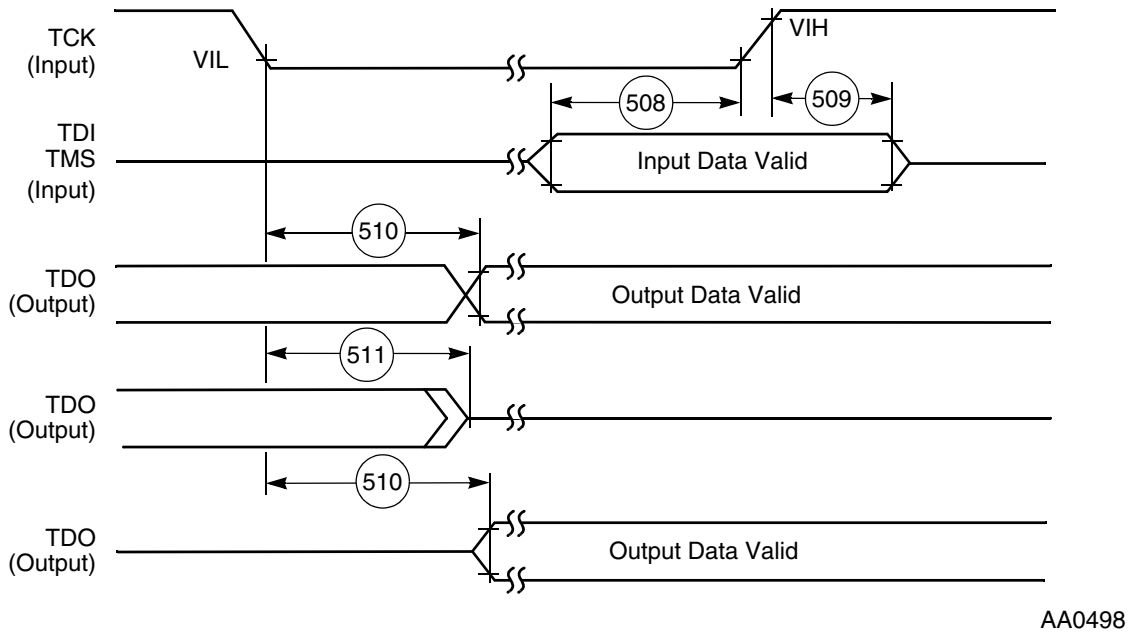
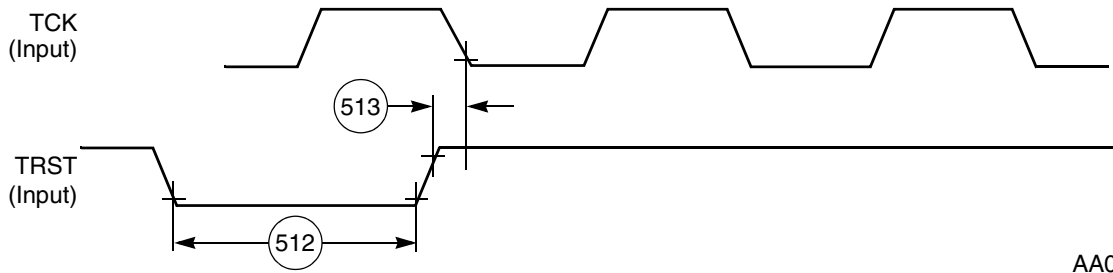

Figure 3-51 Test Access Port Timing Diagram



AA0499

Figure 3-52 $\overline{\text{TRST}}$ Timing Diagram

3.19 OnCE Module Timing

Table 3-29 OnCE Module Timing¹

| No. | Characteristics | Expression | 100 MHz | | Unit |
|-----|--------------------------------------------------------------------------------|--------------------------------------|---------|------|------|
| | | | Min | Max | |
| 500 | TCK frequency of operation | $1/(T_C \times 3)$, max 22.0 MHz | 0.0 | 22.0 | MHz |
| 514 | $\overline{\text{DE}}$ assertion time in order to enter Debug mode | $1.5 \times T_C + 10.0$ | 25.0 | — | ns |
| 515 | Response time when DSP56362 is executing NOP instructions from internal memory | $5.5 \times T_C + 30.0$ | — | 85.0 | ns |
| 516 | Debug acknowledge assertion time | $3 \times T_C + 10.0$ | 40.0 | — | ns |

¹ $V_{CC} = 3.3 \text{ V} \pm 0.16 \text{ V}$; $T_J = 0^\circ\text{C}$ to $+100^\circ\text{C}$, $C_L = 50 \text{ pF}$

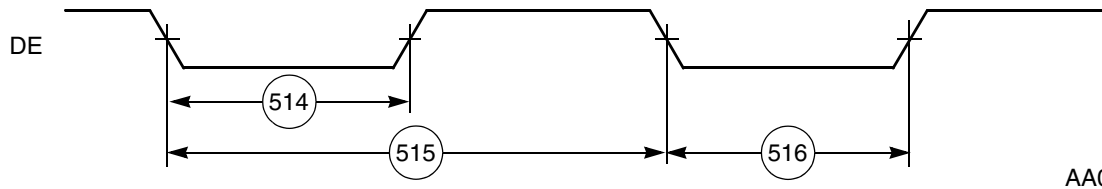

AA0500

Figure 3-53 OnCE—Debug Request

NOTES

4 Packaging

4.1 Pin-out and Package Information

This section provides information about the available package for this product, including diagrams of the package pinouts and tables describing how the signals described in [Section 2, “Signal/Connection Descriptions”](#) are allocated for the package. The DSP56362 is available in a 144-pin LQFP package.

4.2 LQFP Package Description

Top view of the LQFP package is shown in [Figure 4-1](#) with its pin-outs. The LQFP package mechanical drawing is shown in [Figure 4-2](#).

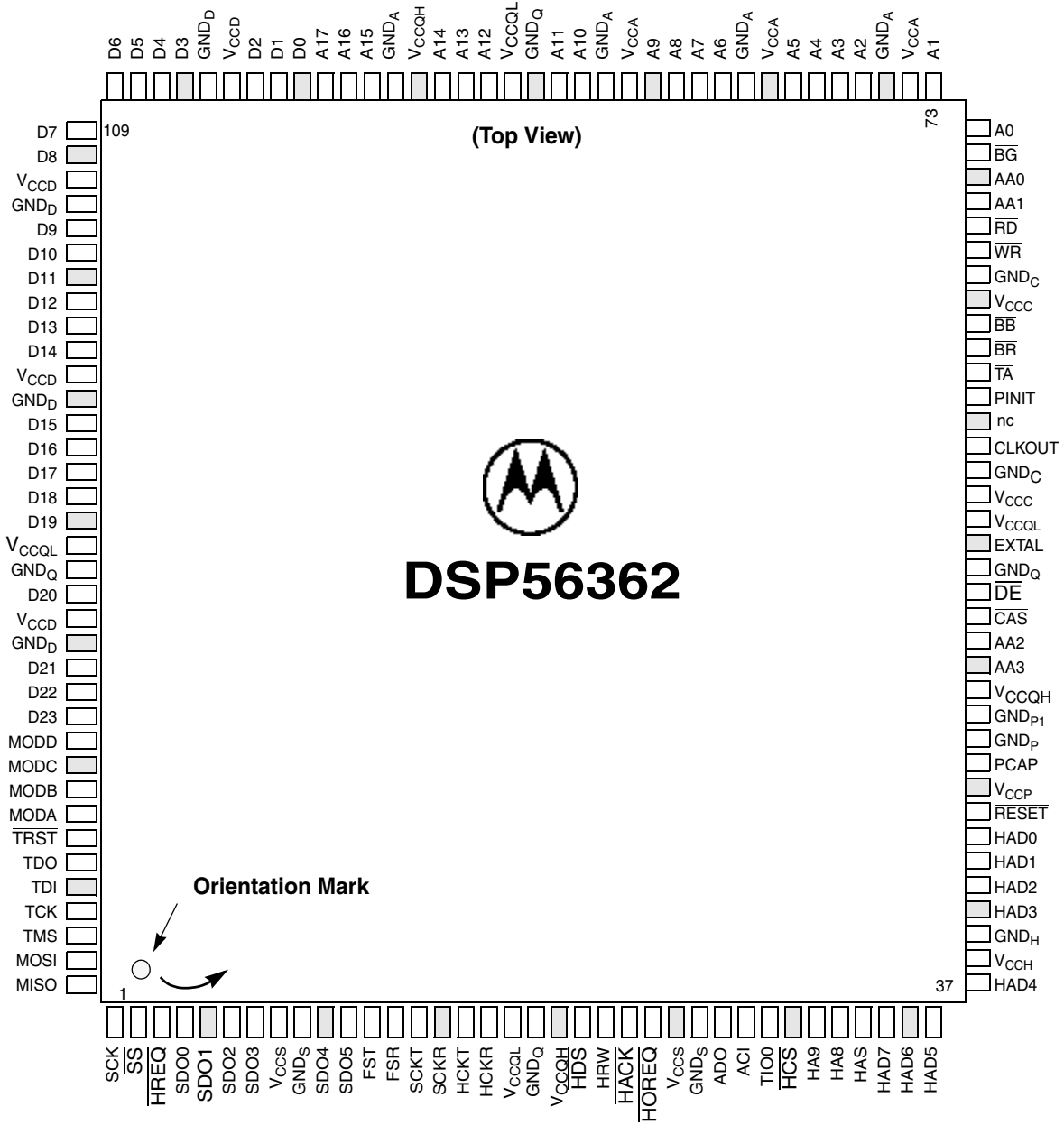

Note: Because of size constraints in this figure, only one name is shown for multiplexed pins. Refer to [Table 4-1](#) and [Table 4-2](#) for detailed information about pin functions and signal names.

AA0301

Figure 4-1 DSP56362 Thin Quad Flat Pack (LQFP), Top View

Table 4-1 DSP56362 LQFP Signal Identification by Pin Number

| Pin No. | Signal Name ¹ | Pin No. | Signal Name ¹ | Pin No. | Signal Name ¹ |
|---------|---------------------------------------------------------------------------|---------|---------------------------------------------|---------|-------------------------------|
| 1 | SCK/SCL | 26 | GND _S | 51 | AA2/ $\overline{\text{RAS2}}$ |
| 2 | $\overline{\text{SS}}$ /HA2 | 27 | ADO or PD1 | 52 | $\overline{\text{CAS}}$ |
| 3 | $\overline{\text{HREQ}}$ | 28 | ACI or PD0 | 53 | $\overline{\text{DE}}$ |
| 4 | SDO0 or PC11 | 29 | TIO0 | 54 | GND _Q |
| 5 | $\overline{\text{SDO1}}$ or $\overline{\text{PC10}}$ | 30 | $\overline{\text{HCS}}$ /HCS, HA10, or PB13 | 55 | EXTAL |
| 6 | SDO2/SDI3 or PC9 | 31 | HA2, HA9, or PB10 | 56 | V _{CCQL} |
| 7 | SDO3/SDI2 or PC8 | 32 | HA1, HA8, or PB9 | 57 | V _{CCC} |
| 8 | V _{CCS} | 33 | HA0, $\overline{\text{HAS}}$ /HAS, or PB8 | 58 | GND _C |
| 9 | GND _S | 34 | H7, HAD7, or PB7 | 59 | CLKOUT |
| 10 | SDO4/SDI1 or PC7 | 35 | H6, HAD6, or PB6 | 60 | NC (not connected) |
| 11 | SDO5/SDI0 or PC6 | 36 | H5, HAD5, or PB5 | 61 | $\overline{\text{PINIT/NMI}}$ |
| 12 | FST or PC4 | 37 | H4, HAD4, or PB4 | 62 | $\overline{\text{TA}}$ |
| 13 | FSR or PC1 | 38 | V _{CCH} | 63 | $\overline{\text{BR}}$ |
| 14 | SCKT or PC3 | 39 | GND _H | 64 | $\overline{\text{BB}}$ |
| 15 | SCKR or PC0 | 40 | H3, HAD3, or PB3 | 65 | V _{CCC} |
| 16 | HCKT or PC5 | 41 | H2, HAD2, or PB2 | 66 | GND _C |
| 17 | HCKR or PC2 | 42 | H1, HAD1, or PB1 | 67 | $\overline{\text{WR}}$ |
| 18 | V _{CCQL} | 43 | H0, HAD0, or PB0 | 68 | $\overline{\text{RD}}$ |
| 19 | GND _Q | 44 | $\overline{\text{RESET}}$ | 69 | AA1/ $\overline{\text{RAS1}}$ |
| 20 | V _{CCQH} | 45 | V _{CCP} | 70 | AA0/ $\overline{\text{RAS0}}$ |
| 21 | $\overline{\text{HDS}}$ /HDS, $\overline{\text{HWR}}$ /HWR, or PB12 | 46 | PCAP | 71 | $\overline{\text{BG}}$ |
| 22 | HRW, $\overline{\text{HRD}}$ /HRD, or PB11 | 47 | GND _P | 72 | A0 |
| 23 | $\overline{\text{HACK}}$ /HACK, $\overline{\text{HRRQ}}$ /HRRQ, or PB15 | 48 | GND _{P1} | 73 | A1 |
| 24 | $\overline{\text{HOREQ}}$ /HOREQ, $\overline{\text{HTRQ}}$ /HTRQ, or PB14 | 49 | V _{CCQH} | 74 | V _{CCA} |
| 25 | V _{CCS} | 50 | AA3/ $\overline{\text{RAS3}}$ | 75 | GND _A |

Table 4-1 DSP56362 LQFP Signal Identification by Pin Number (continued)

| Pin No. | Signal Name ¹ | Pin No. | Signal Name ¹ | Pin No. | Signal Name ¹ |
|---------|--------------------------|---------|--------------------------|---------|--------------------------------|
| 76 | A2 | 99 | A17 | 122 | D16 |
| 77 | A3 | 100 | D0 | 123 | D17 |
| 78 | A4 | 101 | D1 | 124 | D18 |
| 79 | A5 | 102 | D2 | 125 | D19 |
| 80 | V _{CCA} | 103 | V _{CCD} | 126 | V _{CCQL} |
| 81 | GND _A | 104 | GND _D | 127 | GND _Q |
| 82 | A6 | 105 | D3 | 128 | D20 |
| 83 | A7 | 106 | D4 | 129 | V _{CCD} |
| 84 | A8 | 107 | D5 | 130 | GND _D |
| 85 | A9 | 108 | D6 | 131 | D21 |
| 86 | V _{CCA} | 109 | D7 | 132 | D22 |
| 87 | GND _A | 110 | D8 | 133 | D23 |
| 88 | A10 | 111 | V _{CCD} | 134 | MODD/ $\overline{\text{IRQD}}$ |
| 89 | A11 | 112 | GND _D | 135 | MODC/ $\overline{\text{IRQC}}$ |
| 90 | GND _Q | 113 | D9 | 136 | MODB/ $\overline{\text{IRQB}}$ |
| 91 | V _{CCQL} | 114 | D10 | 137 | MODA/ $\overline{\text{IRQA}}$ |
| 92 | A12 | 115 | D11 | 138 | $\overline{\text{TRST}}$ |
| 93 | A13 | 116 | D12 | 139 | TDO |
| 94 | A14 | 117 | D13 | 140 | TDI |
| 95 | V _{CCQH} | 118 | D14 | 141 | TCK |
| 96 | GND _A | 119 | V _{CCD} | 142 | TMS |
| 97 | A15 | 120 | GND _D | 143 | MOSI/HA0 |
| 98 | A16 | 121 | D15 | 144 | MISO/SDA |

¹ Signal names are based on configured functionality. Most pins supply a single signal. Some pins provide a signal with dual functionality, such as the MODx/ $\overline{\text{IRQx}}$ pins that select an operating mode after $\overline{\text{RESET}}$ is deasserted, but act as interrupt lines during operation. Some signals have configurable polarity; these names are shown with and without overbars, such as HAS/HAS. Some pins have two or more configurable functions; names assigned to these pins indicate the function for a specific configuration. For example, pin 34 is data line H7 in nonmultiplexed bus mode, data/address line HAD7 in multiplexed bus mode, or GPIO line PB7 when the GPIO function is enabled for this pin.

Table 4-2 DSP56362 LQFP Signal Identification by Name

| Signal Name | Pin No. | Signal Name | Pin No. | Signal Name | Pin No. |
|-----------------|---------|------------------|---------|------------------------|---------|
| not connected | 60 | D13 | 117 | GND _{P1} | 48 |
| A0 | 72 | D14 | 118 | GND _Q | 19 |
| A1 | 73 | D15 | 121 | GND _Q | 54 |
| A10 | 88 | D16 | 122 | GND _Q | 90 |
| A11 | 89 | D17 | 123 | GND _Q | 127 |
| A12 | 92 | D18 | 124 | GND _S | 9 |
| A13 | 93 | D19 | 125 | GND _S | 26 |
| A14 | 94 | D2 | 102 | H0 | 43 |
| A15 | 97 | D20 | 128 | H1 | 42 |
| A16 | 98 | D21 | 131 | H2 | 41 |
| A17 | 99 | D22 | 132 | H3 | 40 |
| A2 | 76 | D23 | 133 | H4 | 37 |
| A3 | 77 | D3 | 105 | H5 | 36 |
| A4 | 78 | D4 | 106 | H6 | 35 |
| A5 | 79 | D5 | 107 | H7 | 34 |
| A6 | 82 | D6 | 108 | HA0 | 33 |
| A7 | 83 | D7 | 109 | HA0 | 143 |
| A8 | 84 | D8 | 110 | HA1 | 32 |
| A9 | 85 | D9 | 113 | HA10 | 30 |
| AA0 | 70 | \overline{DE} | 53 | HA2 | 2 |
| AA1 | 69 | EXTAL | 55 | HA2 | 31 |
| AA2 | 51 | FSR | 13 | HA8 | 32 |
| AA3 | 50 | FST | 12 | HA9 | 31 |
| ACI | 28 | GND _A | 75 | $\overline{HACK}/HACK$ | 23 |
| ADO | 27 | GND _A | 81 | HAD0 | 43 |
| \overline{BB} | 64 | GND _A | 87 | HAD1 | 42 |
| BG | 71 | GND _A | 96 | HAD2 | 41 |

Table 4-2 DSP56362 LQFP Signal Identification by Name (continued)

| Signal Name | Pin No. | Signal Name | Pin No. | Signal Name | Pin No. |
|----------------------------------------|---------|--------------------------|---------|------------------------------------|---------|
| $\overline{\text{BR}}$ | 63 | GND _C | 58 | HAD3 | 40 |
| $\overline{\text{CAS}}$ | 52 | GND _C | 66 | HAD4 | 37 |
| CLKOUT | 59 | GND _D | 104 | HAD5 | 36 |
| D0 | 100 | GND _D | 112 | HAD6 | 35 |
| D1 | 101 | GND _D | 120 | HAD7 | 34 |
| D10 | 114 | GND _D | 130 | $\overline{\text{HAS}}/\text{HAS}$ | 33 |
| D11 | 115 | GND _H | 39 | $\overline{\text{HCS}}/\text{HCS}$ | 30 |
| D12 | 116 | GND _P | 47 | $\overline{\text{HDS}}/\text{HDS}$ | 21 |
| $\overline{\text{HOREQ}}/\text{HOREQ}$ | 24 | PB9 | 32 | SDO3 | 7 |
| $\overline{\text{HRD}}/\text{HRD}$ | 22 | PC0 | 15 | SDO4 | 10 |
| $\overline{\text{HREQ}}$ | 3 | PC1 | 13 | SDO5 | 11 |
| $\overline{\text{HRRQ}}/\text{HRRQ}$ | 23 | PC10 | 5 | $\overline{\text{SS}}$ | 2 |
| HRW | 22 | PC11 | 4 | $\overline{\text{TA}}$ | 62 |
| HCKR | 17 | PC2 | 17 | TCK | 141 |
| HCKT | 16 | PC3 | 14 | TDI | 140 |
| $\overline{\text{HTRQ}}/\text{HTRQ}$ | 24 | PC4 | 12 | TDO | 139 |
| $\overline{\text{HWR}}/\text{HWR}$ | 21 | PC5 | 16 | TIO0 | 29 |
| $\overline{\text{IRQA}}$ | 137 | PC6 | 11 | TMS | 142 |
| $\overline{\text{IRQB}}$ | 136 | PC7 | 10 | $\overline{\text{TRST}}$ | 138 |
| $\overline{\text{IRQC}}$ | 135 | PC8 | 7 | V _{CCA} | 74 |
| IRQD | 134 | PC9 | 6 | V _{CCA} | 80 |
| MISO | 144 | PCAP | 46 | V _{CCA} | 86 |
| MODA | 137 | PD0 | 28 | V _{CCC} | 57 |
| MODB | 136 | PD1 | 27 | V _{CCC} | 65 |
| MODC | 135 | PINIT | 61 | V _{CCD} | 103 |
| MODD | 134 | $\overline{\text{RAS0}}$ | 70 | V _{CCD} | 111 |
| MOSI | 143 | $\overline{\text{RAS1}}$ | 69 | V _{CCD} | 119 |

Table 4-2 DSP56362 LQFP Signal Identification by Name (continued)

| Signal Name | Pin No. | Signal Name | Pin No. | Signal Name | Pin No. |
|-------------------------|---------|--------------------------|---------|------------------------|---------|
| $\overline{\text{NMI}}$ | 61 | $\overline{\text{RAS2}}$ | 52 | V_{CCD} | 129 |
| PB0 | 43 | $\overline{\text{RAS3}}$ | 51 | V_{CCH} | 38 |
| PB1 | 42 | $\overline{\text{RD}}$ | 68 | V_{CCP} | 45 |
| PB10 | 31 | RESET | 44 | V_{CCQH} | 20 |
| PB11 | 22 | SCK | 1 | V_{CCQH} | 49 |
| PB12 | 21 | SCKR | 15 | V_{CCQH} | 95 |
| PB13 | 30 | SCKT | 14 | V_{CCQL} | 18 |
| PB14 | 24 | SCL | 1 | V_{CCQL} | 56 |
| PB15 | 23 | SDA | 144 | V_{CCQL} | 91 |
| PB2 | 41 | SDI0 | 11 | V_{CCQL} | 126 |
| PB3 | 40 | SDI1 | 10 | V_{CCS} | 8 |
| PB4 | 37 | SDI2 | 7 | V_{CCS} | 25 |
| PB5 | 36 | SDI3 | 6 | $\overline{\text{WR}}$ | 67 |
| PB6 | 35 | SDO0 | 4 | | |
| PB7 | 34 | SDO1 | 5 | | |
| PB8 | 33 | SDO2 | 6 | | |

4.3 LQFP PACKAGE MECHANICAL DRAWING

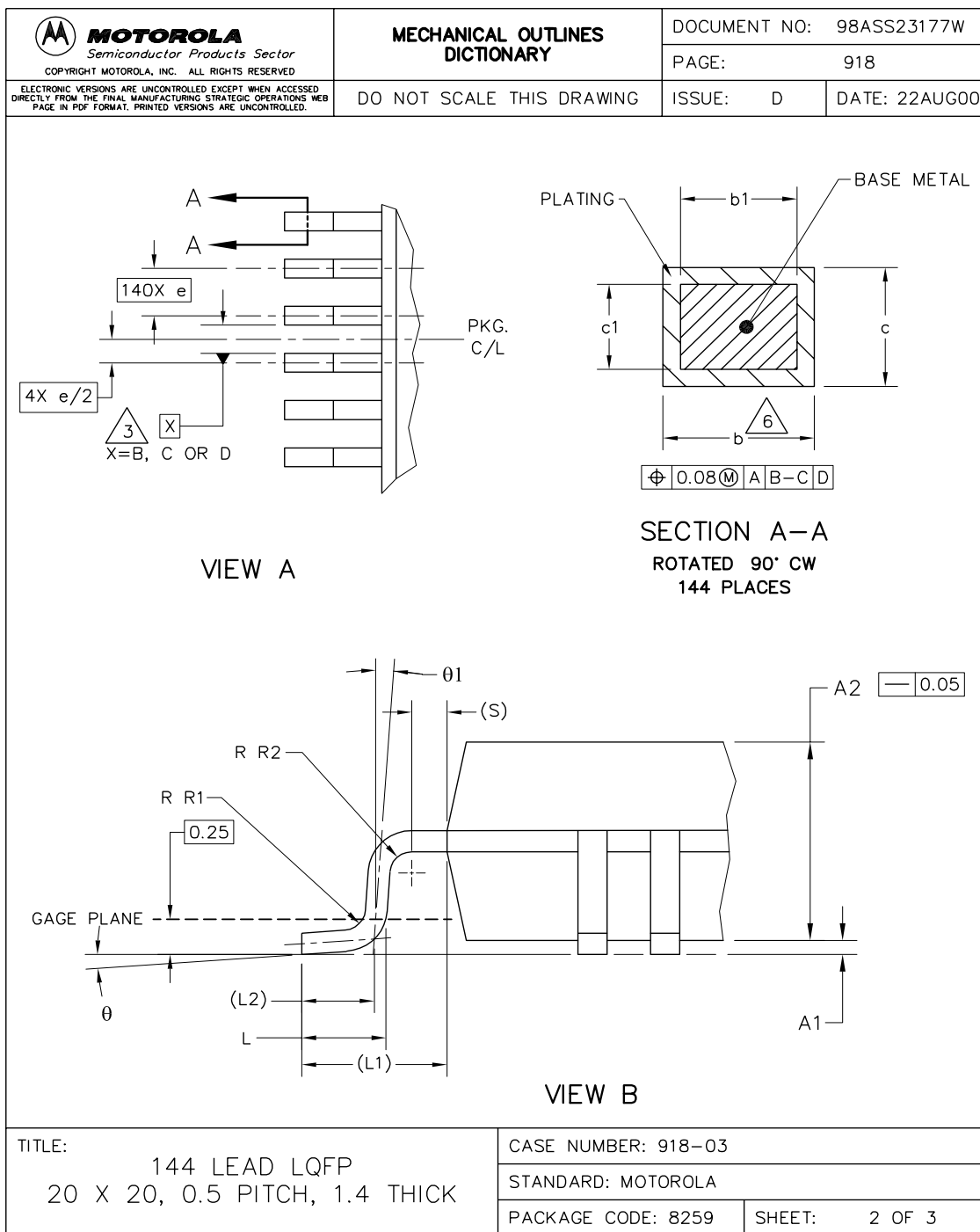

Figure 4-2 DSP56362 144-pin LQFP Package

5 Design Considerations

5.1 Thermal Design Considerations

An estimation of the chip junction temperature, T_J , in °C can be obtained from the following equation:

$$T_J = T_A + (P_D \times R_{\theta JA})$$

Where:

T_A = ambient temperature °C

$R_{\theta JA}$ = package junction-to-ambient thermal resistance °C/W

P_D = power dissipation in package W

Historically, thermal resistance has been expressed as the sum of a junction-to-case thermal resistance and a case-to-ambient thermal resistance.

$$R_{\theta JA} = R_{\theta JC} + R_{\theta CA}$$

Where:

$R_{\theta JA}$ = package junction-to-ambient thermal resistance °C/W

$R_{\theta JC}$ = package junction-to-case thermal resistance °C/W

$R_{\theta CA}$ = package case-to-ambient thermal resistance °C/W

$R_{\theta JC}$ is device-related and cannot be influenced by the user. The user controls the thermal environment to change the case-to-ambient thermal resistance, $R_{\theta CA}$. For example, the user can change the air flow around the device, add a heat sink, change the mounting arrangement on the printed circuit board (PCB), or otherwise change the thermal dissipation capability of the area surrounding the device on a PCB. This model is most useful for ceramic packages with heat sinks; some 90% of the heat flow is dissipated through the case to the heat sink and out to the ambient environment. For ceramic packages, in situations where the heat flow is split between a path to the case and an alternate path through the PCB, analysis of the device thermal performance may need the additional modeling capability of a system level thermal simulation tool.

The thermal performance of plastic packages is more dependent on the temperature of the PCB to which the package is mounted. Again, if the estimations obtained from $R_{\theta JA}$ do not satisfactorily answer whether the thermal performance is adequate, a system level model may be appropriate.

A complicating factor is the existence of three common ways for determining the junction-to-case thermal resistance in plastic packages.

Electrical Design Considerations

- To minimize temperature variation across the surface, the thermal resistance is measured from the junction to the outside surface of the package (case) closest to the chip mounting area when that surface has a proper heat sink.
- To define a value approximately equal to a junction-to-board thermal resistance, the thermal resistance is measured from the junction to where the leads are attached to the case.
- If the temperature of the package case (T_T) is determined by a thermocouple, the thermal resistance is computed using the value obtained by the equation

$$(T_J - T_T)/P_D.$$

As noted above, the junction-to-case thermal resistances quoted in this data sheet are determined using the first definition. From a practical standpoint, that value is also suitable for determining the junction temperature from a case thermocouple reading in forced convection environments. In natural convection, using the junction-to-case thermal resistance to estimate junction temperature from a thermocouple reading on the case of the package will estimate a junction temperature slightly hotter than actual temperature. Hence, the new thermal metric, thermal characterization parameter or Ψ_{JT} , has been defined to be $(T_J - T_T)/P_D$. This value gives a better estimate of the junction temperature in natural convection when using the surface temperature of the package. Remember that surface temperature readings of packages are subject to significant errors caused by inadequate attachment of the sensor to the surface and to errors caused by heat loss to the sensor. The recommended technique is to attach a 40-gauge thermocouple wire and bead to the top center of the package with thermally conductive epoxy.

5.2 Electrical Design Considerations

CAUTION

This device contains circuitry protecting against damage due to high static voltage or electrical fields. However, normal precautions should be taken to avoid exceeding maximum voltage ratings. Reliability of operation is enhanced if unused inputs are tied to an appropriate logic voltage level (e.g., either GND or V_{CC}). The suggested value for a pullup or pulldown resistor is 10 k ohm.

Use the following list of recommendations to assure correct DSP operation:

- Provide a low-impedance path from the board power supply to each V_{CC} pin on the DSP and from the board ground to each GND pin.
- Use at least six 0.01–0.1 μF bypass capacitors positioned as close as possible to the four sides of the package to connect the V_{CC} power source to GND.
- Ensure that capacitor leads and associated printed circuit traces that connect to the chip V_{CC} and GND pins are less than 1.2 cm (0.5 inch) per capacitor lead.
- Use at least a four-layer PCB with two inner layers for V_{CC} and GND.
- Because the DSP output signals have fast rise and fall times, PCB trace lengths should be minimal. This recommendation particularly applies to the address and data buses as well as the $\overline{\text{IRQA}}$, $\overline{\text{IRQB}}$, $\overline{\text{IRQC}}$, $\overline{\text{IRQD}}$, $\overline{\text{TA}}$, and $\overline{\text{BG}}$ pins. Maximum PCB trace lengths on the order of 15 cm (6 inches) are recommended.

- Consider all device loads as well as parasitic capacitance due to PCB traces when calculating capacitance. This is especially critical in systems with higher capacitive loads that could create higher transient currents in the V_{CC} and GND circuits.
- All inputs must be terminated (i.e., not allowed to float) using CMOS levels, except for the pins with internal pull-up resistors (TRST, TMS, DE, TCK, and TDI).
- Take special care to minimize noise levels on the V_{CCP} , GND_P , and GND_{P1} pins.
- If multiple DSP56362 devices are on the same board, check for cross-talk or excessive spikes on the supplies due to synchronous operation of the devices.
- RESET must be asserted when the chip is powered up. A stable EXTAL signal should be supplied before deassertion of RESET.
- At power-up, ensure that the voltage difference between the 5 V tolerant pins and the chip V_{CC} never exceeds 3.95 V.

5.3 Power Consumption Considerations

Power dissipation is a key issue in portable DSP applications. Some of the factors which affect current consumption are described in this section. Most of the current consumed by CMOS devices is alternating current (ac), which is charging and discharging the capacitances of the pins and internal nodes.

Current consumption is described by the following formula:

$$I = C \times V \times f$$

where:

- C = node/pin capacitance
- V = voltage swing
- f = frequency of node/pin toggle

Example 1. Current Consumption

For a Port A address pin loaded with 50 pF capacitance, operating at 3.3 V, and with a 100 MHz clock, toggling at its maximum possible rate (50 MHz), the current consumption is

$$I = 50 \times 10^{-12} \times 3.3 \times 50 \times 10^6 = 8.25\text{mA}$$

The maximum internal current (I_{CC1max}) value reflects the typical possible switching of the internal buses on best-case operation conditions, which is not necessarily a real application case. The typical internal current (I_{CC1typ}) value reflects the average switching of the internal buses on typical operating conditions.

For applications that require very low current consumption, do the following:

- Set the EBD bit when not accessing external memory.
- Minimize external memory accesses and use internal memory accesses.
- Minimize the number of pins that are switching.
- Minimize the capacitive load on the pins.
- Connect the unused inputs to pull-up or pull-down resistors.

PLL Performance Issues

- Disable unused peripherals.
- Disable unused pin activity (e.g., CLKOUT, XTAL).

One way to evaluate power consumption is to use a current per MIPS measurement methodology to minimize specific board effects (i.e., to compensate for measured board current not caused by the DSP). A benchmark power consumption test algorithm is listed in **Appendix A**. Use the test algorithm, specific test current measurements, and the following equation to derive the current per MIPS value.

$$1\text{MIPS} = 1\text{MHz} = (I_{\text{typF2}} - I_{\text{typF1}}) \times (F2 - F1)$$

where :

I_{typF2} = current at F2

I_{typF1} = current at F1

F2 = high frequency (any specified operating frequency)

F1 = low frequency (any specified operating frequency lower than F2)

NOTE

F1 should be significantly less than F2. For example, F2 could be 66 MHz and F1 could be 33 MHz. The degree of difference between F1 and F2 determines the amount of precision with which the current rating can be determined for an application.

5.4 PLL Performance Issues

The following explanations should be considered as general observations on expected PLL behavior. There is no testing that verifies these exact numbers. These observations were measured on a limited number of parts and were not verified over the entire temperature and voltage ranges.

5.4.1 Phase Skew Performance

The phase skew of the PLL is defined as the time difference between the falling edges of EXTAL and CLKOUT for a given capacitive load on CLKOUT, over the entire process, temperature, and voltage ranges. As defined in [Figure 3-1](#), for input frequencies greater than 15 MHz and the MF ≤ 4 , this skew is greater than or equal to 0.0 ns and less than 1.8 ns; otherwise, this skew is not guaranteed. However, for MF < 10 and input frequencies greater than 10 MHz, this skew is between -1.4 ns and +3.2 ns.

5.4.2 Phase Jitter Performance

The phase jitter of the PLL is defined as the variations in the skew between the falling edges of EXTAL and CLKOUT for a given device in specific temperature, voltage, input frequency, MF, and capacitive load on CLKOUT. These variations are a result of the PLL locking mechanism. For input frequencies greater than 15 MHz and MF ≤ 4 , this jitter is less than ± 0.6 ns; otherwise, this jitter is not guaranteed. However, for MF < 10 and input frequencies greater than 10 MHz, this jitter is less than ± 2 ns.

5.4.3 Frequency Jitter Performance

The frequency jitter of the PLL is defined as the variation of the frequency of CLKOUT. For small MF ($MF < 10$) this jitter is smaller than 0.5%. For mid-range MF ($10 < MF < 500$) this jitter is between 0.5% and approximately 2%. For large MF ($MF > 500$), the frequency jitter is 2–3%.

5.4.4 Input (EXTAL) Jitter Requirements

The allowed jitter on the frequency of EXTAL is 0.5%. If the rate of change of the frequency of EXTAL is slow (i.e., it does not jump between the minimum and maximum values in one cycle) or the frequency of the jitter is fast (i.e., it does not stay at an extreme value for a long time), then the allowed jitter can be 2%. The phase and frequency jitter performance results are only valid if the input jitter is less than the prescribed values.

5.5 Host Port Considerations

Careful synchronization is required when reading multi-bit registers that are written by another asynchronous system. This synchronization is a common problem when two asynchronous systems are connected, as they are in the host interface. The following paragraphs present considerations for proper operation.

5.5.1 Host Programming Considerations

- **Unsynchronized Reading of Receive Byte Registers**—When reading the receive byte registers, receive register high (RXH), receive register middle (RXM), or receive register low (RXL), the host interface programmer should use interrupts or poll the receive register data full (RXDF) flag that indicates whether data is available. This ensures that the data in the receive byte registers will be valid.
- **Overwriting Transmit Byte Registers**—The host interface programmer should not write to the transmit byte registers, transmit register high (TXH), transmit register middle (TXM), or transmit register low (TXL), unless the transmit register data empty (TXDE) bit is set, indicating that the transmit byte registers are empty. This ensures that the transmit byte registers will transfer valid data to the host receive (HRX) register.
- **Synchronization of Status Bits from DSP to Host**—HC, $\overline{\text{HOREQ}}$, DMA, HF3, HF2, TRDY, TXDE, and RXDF status bits are set or cleared from inside the DSP and read by the host processor (refer to the user's manual for descriptions of these status bits). The host can read these status bits very quickly without regard to the clock rate used by the DSP, but the state of the bit could be changing during the read operation. This is not generally a system problem, because the bit will be read correctly in the next pass of any host polling routine.

However, if the host asserts $\overline{\text{HEN}}$ for more than timing number 31, with a minimum cycle time of timing number 31 + 32, then these status bits are guaranteed to be stable. Exercise care when reading status bits HF3 and HF2 as an encoded pair. If the DSP changes HF3 and HF2 from 00 to 11, there is a small probability that the host could read the bits during the transition and receive 01 or 10 instead of 11. If the combination of HF3 and HF2 has

significance, the host could read the wrong combination. Therefore, read the bits twice and check for consensus.

- **Overwriting the Host Vector**—The host interface programmer should change the host vector (HV) register only when the host command (HC) bit is clear. This ensures that the DSP interrupt control logic will receive a stable vector.
- **Cancelling a Pending Host Command Exception**—The host processor may elect to clear the HC bit to cancel the host command exception request at any time before it is recognized by the DSP. Because the host does not know exactly when the exception will be recognized (due to exception processing synchronization and pipeline delays), the DSP may execute the host command exception after the HC bit is cleared. For these reasons, the HV bits must not be changed at the same time that the HC bit is cleared.
- **Variance in the Host Interface Timing**—The host interface (HDI) may vary (e.g. due to the PLL lock time at reset). Therefore, a host which attempts to load (bootstrap) the DSP should first make sure that the part has completed its HI port programming (e.g., by setting the INIT bit in ICR then polling it and waiting it to be cleared, then reading the ISR or by writing the TREQ/RREQ together with the INIT and then polling INIT, ISR, and the $\overline{\text{HOREQ}}$ pin).

5.5.2 DSP Programming Considerations

- **Synchronization of Status Bits from Host to DSP**—DMA, HF1, HF0, HCP, HTDE, and HRDF status bits are set or cleared by the host processor side of the interface. These bits are individually synchronized to the DSP clock. (Refer to the user's manual for descriptions of these status bits.)
- **Reading HF0 and HF1 as an Encoded Pair**—Care must be exercised when reading status bits HF0 and HF1 as an encoded pair, (i.e., the four combinations 00, 01, 10, and 11 each have significance). A very small probability exists that the DSP will read the status bits synchronized during transition. Therefore, HF0 and HF1 should be read twice and checked for consensus.

6 Ordering Information

Consult a Freescale Semiconductor, Inc. sales office or authorized distributor to determine product availability and to place an order.

For information on ordering this and all DSP Audio products, review the SG1004 selector guide at <http://www.freescale.com>.

NOTES

Appendix A Power Consumption Benchmark

The following benchmark program permits evaluation of DSP power usage in a test situation. It enables the PLL, disables the external clock, and uses repeated multiply-accumulate instructions with a set of synthetic DSP application data to emulate intensive sustained DSP operation.

```

;*****;*****
;*****
;* ;* CHECKS    Typical Power Consumption
;*****;*****
        page      200,55,0,0,0
        nolist

I_VEC EQU $000000 ; Interrupt vectors for program debug only
START EQU $8000   ; MAIN (external) program starting address
INT_PROG EQU $100 ; INTERNAL program memory starting address
INT_XDAT EQU $0   ; INTERNAL X-data memory starting address
INT_YDAT EQU $0   ; INTERNAL Y-data memory starting address

        INCLUDE "ioequ.asm"
        INCLUDE "intequ.asm"

        list

        org      P:START
;
        movewp  #0123FF,x:M_BCR; BCR: Area 3 : 1 w.s (SRAM)
; Default: 1 w.s (SRAM)
;
        movewp  #0d0000,x:M_PCTL           ; XTAL disable
                ; PLL enable
                ; CLKOUT disable
;
; Load the program
;
        move    #INT_PROG,r0
        move    #PROG_START,r1
        do      #(PROG_END-PROG_START),PLOAD_LOOP
        move    p:(r1)+,x0
        move    x0,p:(r0)+
        nop
PLOAD_LOOP
;
; Load the X-data
;
        move    #INT_XDAT,r0
        move    #XDAT_START,r1

```

```

        do          # (XDAT_END-XDAT_START), XLOAD_LOOP
        move        p: (r1)+, x0
        move        x0, x: (r0)+
XLOAD_LOOP
;
; Load the Y-data
;
        move        #INT_YDAT, r0
        move        #YDAT_START, r1
        do          # (YDAT_END-YDAT_START), YLOAD_LOOP
        move        p: (r1)+, x0
        move        x0, y: (r0)+
YLOAD_LOOP
;

        jmp        INT_PROG

PROG_START
        move        #$0, r0
        move        #$0, r4
        move        #$3f, m0
        move        #$3f, m4
;
        clr        a
        clr        b
        move        #$0, x0
        move        #$0, x1
        move        #$0, y0
        move        #$0, y1
        bset       #4, omr          ; ebd
;
sbr      dor        #60, _end
        mac        x0, y0, a    x: (r0)+, x1          y: (r4)+, y1
        mac        x1, y1, a    x: (r0)+, x0          y: (r4)+, y0
        add        a, b
        mac        x0, y0, a    x: (r0)+, x1
        mac        x1, y1, a          y: (r4)+, y0
        move       b1, x: $ff
_end
        bra        sbr
        nop
        nop
        nop
        nop
PROG_END
        nop
        nop

XDAT_START
;
        org        x: 0
        dc        $262EB9
        dc        $86F2FE
        dc        $E56A5F
        dc        $616CAC

```

| | |
|----|----------|
| dc | \$8FFD75 |
| dc | \$9210A |
| dc | \$A06D7B |
| dc | \$CEA798 |
| dc | \$8DFBF1 |
| dc | \$A063D6 |
| dc | \$6C6657 |
| dc | \$C2A544 |
| dc | \$A3662D |
| dc | \$A4E762 |
| dc | \$84F0F3 |
| dc | \$E6F1B0 |
| dc | \$B3829 |
| dc | \$8BF7AE |
| dc | \$63A94F |
| dc | \$EF78DC |
| dc | \$242DE5 |
| dc | \$A3E0BA |
| dc | \$EBAB6B |
| dc | \$8726C8 |
| dc | \$CA361 |
| dc | \$2F6E86 |
| dc | \$A57347 |
| dc | \$4BE774 |
| dc | \$8F349D |
| dc | \$A1ED12 |
| dc | \$4BFCE3 |
| dc | \$EA26E0 |
| dc | \$CD7D99 |
| dc | \$4BA85E |
| dc | \$27A43F |
| dc | \$A8B10C |
| dc | \$D3A55 |
| dc | \$25EC6A |
| dc | \$2A255B |
| dc | \$A5F1F8 |
| dc | \$2426D1 |
| dc | \$AE6536 |
| dc | \$CBBC37 |
| dc | \$6235A4 |
| dc | \$37F0D |
| dc | \$63BEC2 |
| dc | \$A5E4D3 |
| dc | \$8CE810 |
| dc | \$3FF09 |
| dc | \$60E50E |
| dc | \$CFFB2F |
| dc | \$40753C |
| dc | \$8262C5 |
| dc | \$CA641A |
| dc | \$EB3B4B |
| dc | \$2DA928 |
| dc | \$AB6641 |
| dc | \$28A7E6 |
| dc | \$4E2127 |

```

dc      $482FD4
dc      $7257D
dc      $E53C72
dc      $1A8C3
dc      $E27540

```

XDAT_END

YDAT_START

```

;      org      y:0
dc      $5B6DA
dc      $C3F70B
dc      $6A39E8
dc      $81E801
dc      $C666A6
dc      $46F8E7
dc      $AAEC94
dc      $24233D
dc      $802732
dc      $2E3C83
dc      $A43E00
dc      $C2B639
dc      $85A47E
dc      $ABFDDF
dc      $F3A2C
dc      $2D7CF5
dc      $E16A8A
dc      $ECB8FB
dc      $4BED18
dc      $43F371
dc      $83A556
dc      $E1E9D7
dc      $ACA2C4
dc      $8135AD
dc      $2CE0E2
dc      $8F2C73
dc      $432730
dc      $A87FA9
dc      $4A292E
dc      $A63CCF
dc      $6BA65C
dc      $E06D65
dc      $1AA3A
dc      $A1B6EB
dc      $48AC48
dc      $EF7AE1
dc      $6E3006
dc      $62F6C7
dc      $6064F4
dc      $87E41D
dc      $CB2692
dc      $2C3863
dc      $C6BC60
dc      $43A519
dc      $6139DE
dc      $ADF7BF

```



```
dc          $4B3E8C
dc          $6079D5
dc          $E0F5EA
dc          $8230DB
dc          $A3B778
dc          $2BFE51
dc          $E0A6B6
dc          $68FFB7
dc          $28F324
dc          $8F2E8D
dc          $667842
dc          $83E053
dc          $A1FD90
dc          $6B2689
dc          $85B68E
dc          $622EAF
dc          $6162BC
dc          $E4A245
YDAT_END
```

NOTES

Appendix B IBIS Model

```

[IBIS ver]      2.1
[File name]    56362.ibs
[File Rev]     0.0
[Date]        29/6/2000
[Component]    56362
[Manufacturer] Freescale
[Package]
|variable      typ          min          max
R_pkg         45m          22m          75m
L_pkg         2.5nH         1.1nH        4.3nH
C_pkg         1.3pF         1.2pF        1.4pF

```

```

[Pin]signal_name model_name
1 sck             ip5b_io
2 ss_             ip5b_io
3 hreq_          ip5b_io
4 sdo0            ip5b_io
5 sdo1            ip5b_io
6 sdoi23         ip5b_io
7 sdoi32         ip5b_io
8 svcc            power
9 sgnd            gnd
10 sdoi41         ip5b_io
11 sdoi50         ip5b_io
12 fst            ip5b_io
13 fsr            ip5b_io
14 sckt           ip5b_io
15 sckr           ip5b_io
16 hsckt         ip5b_io
17 hsckr         ip5b_io
18 qvccl         power
19 gnd           gnd
20 qvcch         power
21 hp12          ip5b_io
22 hp11          ip5b_io
23 hp15          ip5b_io
24 hp14          ip5b_io
25 svcc          power
26 sgnd          gnd
27 ado           ip5b_io
28 aci           ip5b_io
29 tio           ip5b_io
30 hp13          ip5b_io
31 hp10          ip5b_io
32 hp9           ip5b_io

```

| | | |
|----|---------|---------|
| 33 | hp8 | ip5b_io |
| 34 | hp7 | ip5b_io |
| 35 | hp6 | ip5b_io |
| 36 | hp5 | ip5b_io |
| 37 | hp4 | ip5b_io |
| 38 | svcc | power |
| 39 | sgnd | gnd |
| 40 | hp3 | ip5b_io |
| 41 | hp2 | ip5b_io |
| 42 | hp1 | ip5b_io |
| 43 | hp0 | ip5b_io |
| 44 | ires_ | ip5b_i |
| 45 | pvcc | power |
| 46 | pcap | power |
| 47 | pgnd | gnd |
| 48 | pgnd1 | gnd |
| 49 | qvcch | power |
| 50 | aa3 | icbc_o |
| 51 | aa2 | icbc_o |
| 52 | cas_ | icbc_o |
| 53 | de_ | ipbw_io |
| 54 | qgnd | gnd |
| 55 | cxtdis_ | ixlh_i |
| 56 | qvcc1 | power |
| 57 | cvcc | power |
| 58 | cgnd | gnd |
| 59 | clkout | icba_o |
| 61 | nmi_ | ipbw_i |
| 62 | ta_ | icbc_o |
| 63 | br_ | icbc_o |
| 64 | bb_ | icbc_o |
| 65 | cvcc | power |
| 66 | cgnd | gnd |
| 67 | wr_ | icbc_o |
| 68 | rd_ | icbc_o |
| 69 | aa1 | icbc_o |
| 70 | aa0 | icbc_o |
| 71 | bg_ | icbc_o |
| 72 | eab0 | icba_o |
| 73 | eab1 | icba_o |
| 74 | avcc | power |
| 75 | agnd | gnd |
| 76 | eab2 | icba_o |
| 77 | eab3 | icba_o |
| 78 | eab4 | icba_o |
| 79 | eab5 | icba_o |
| 80 | avcc | power |
| 81 | agnd | gnd |
| 82 | eab6 | icba_o |
| 83 | eab7 | icba_o |
| 84 | eab8 | icba_o |
| 85 | eab9 | icba_o |
| 86 | avcc | power |
| 87 | agnd | gnd |
| 88 | eab10 | icba_o |

| | | |
|-----|-------|---------|
| 89 | eab11 | icba_o |
| 90 | qgnd | gnd |
| 91 | qvcc | power |
| 92 | eab12 | icba_o |
| 93 | eab13 | icba_o |
| 94 | eab14 | icba_o |
| 95 | qvcch | power |
| 96 | agnd | gnd |
| 97 | eab15 | icba_o |
| 98 | eab16 | icba_o |
| 99 | eab17 | icba_o |
| 100 | edb0 | icba_io |
| 101 | edb1 | icba_io |
| 102 | edb2 | icba_io |
| 103 | dvcc | power |
| 104 | dgnd | gnd |
| 105 | edb3 | icba_io |
| 106 | edb4 | icba_io |
| 107 | edb5 | icba_io |
| 108 | edb6 | icba_io |
| 109 | edb7 | icba_io |
| 110 | edb8 | icba_io |
| 111 | dvcc | power |
| 112 | dgnd | gnd |
| 113 | edb9 | icba_io |
| 114 | edb10 | icba_io |
| 115 | edb11 | icba_io |
| 116 | edb12 | icba_io |
| 117 | edb13 | icba_io |
| 118 | edb14 | icba_io |
| 119 | dvcc | power |
| 120 | dgnd | gnd |
| 121 | edb15 | icba_io |
| 122 | edb16 | icba_io |
| 123 | edb17 | icba_io |
| 124 | edb18 | icba_io |
| 125 | edb19 | icba_io |
| 126 | qvcc1 | power |
| 127 | qgnd | gnd |
| 128 | edb20 | icba_io |
| 129 | dvcc | power |
| 130 | dgnd | gnd |
| 131 | edb21 | icba_io |
| 132 | edb22 | icba_io |
| 133 | edb23 | icba_io |
| 134 | irqd_ | ip5b_i |
| 135 | irqc_ | ip5b_i |
| 136 | irqb_ | ip5b_i |
| 137 | irqa_ | ip5b_i |
| 138 | trst_ | ip5b_i |
| 139 | tdo | ip5b_o |
| 140 | tdi | ip5b_i |
| 141 | tck | ip5b_i |
| 142 | tms | ip5b_i |
| 143 | mosi | ip5b_io |

```

144 sda                ip5b_io
|
[Model]                ip5b_i
Model_type              Input
Polarity                Non-Inverting
Vinl= 0.8000v
Vinh= 2.000v
C_comp                 5.00pF          5.00pF          5.00pF
|
|
[Voltage Range]        3.3v          3v          3.6v
[GND_clamp]
|voltage              I (typ)          I (min)          I (max)
|
-3.30e+00             -5.21e+02       -3.65e+02       -5.18e+02
-3.10e+00             -4.69e+02       -3.30e+02       -4.67e+02
-2.90e+00             -4.18e+02       -2.94e+02       -4.16e+02
-2.70e+00             -3.67e+02       -2.59e+02       -3.65e+02
-2.50e+00             -3.16e+02       -2.23e+02       -3.14e+02
-2.30e+00             -2.65e+02       -1.88e+02       -2.63e+02
-2.10e+00             -2.14e+02       -1.52e+02       -2.12e+02
-1.90e+00             -1.63e+02       -1.17e+02       -1.61e+02
-1.70e+00             -1.13e+02       -9.25e+01       -1.10e+02
-1.50e+00             -7.83e+01       -6.88e+01       -7.58e+01
-1.30e+00             -4.43e+01       -4.52e+01       -4.17e+01
-1.10e+00             -1.02e+01       -2.15e+01       -7.67e+00
-9.00e-01             -9.69e-03       -1.18e+00       -7.81e-03
-7.00e-01             -2.83e-04       -5.70e-03       -8.42e-04
-5.00e-01             -1.35e-06       -4.53e-05       -1.00e-05
-3.00e-01             -1.31e-09       -3.74e-07       -8.58e-09
-1.00e-01             -2.92e-11       -3.00e-09       -3.64e-11
0.000e+00             -2.44e-11       -5.14e-10       -2.79e-11
|
|
[Model]                ip5b_io
Model_type              I/O
Polarity                Non-Inverting
Vinl= 0.8000v
Vinh= 2.000v
C_comp                 5.00pF          5.00pF          5.00pF
|
|
[Voltage Range]        3.3v          3v          3.6v
[Pulldown]
|voltage              I (typ)          I (min)          I (max)
|
-3.30e+00             -5.21e+02       -3.65e+02       -5.18e+02
-3.10e+00             -4.69e+02       -3.30e+02       -4.67e+02
-2.90e+00             -4.18e+02       -2.94e+02       -4.16e+02
-2.70e+00             -3.67e+02       -2.59e+02       -3.65e+02
-2.50e+00             -3.16e+02       -2.23e+02       -3.14e+02
-2.30e+00             -2.65e+02       -1.88e+02       -2.63e+02
-2.10e+00             -2.14e+02       -1.52e+02       -2.12e+02
-1.90e+00             -1.63e+02       -1.17e+02       -1.61e+02
-1.70e+00             -1.13e+02       -9.25e+01       -1.10e+02

```

| | | | |
|-----------|-----------|-----------|-----------|
| -1.50e+00 | -7.83e+01 | -6.88e+01 | -7.58e+01 |
| -1.30e+00 | -4.43e+01 | -4.52e+01 | -4.17e+01 |
| -1.10e+00 | -1.02e+01 | -2.15e+01 | -7.69e+00 |
| -9.00e-01 | -5.10e-02 | -1.18e+00 | -5.63e-02 |
| -7.00e-01 | -3.65e-02 | -2.25e-02 | -4.28e-02 |
| -5.00e-01 | -2.65e-02 | -1.38e-02 | -3.12e-02 |
| -3.00e-01 | -1.62e-02 | -8.35e-03 | -1.91e-02 |
| -1.00e-01 | -5.49e-03 | -2.80e-03 | -6.52e-03 |
| 1.000e-01 | 5.377e-03 | 2.744e-03 | 6.427e-03 |
| 3.000e-01 | 1.516e-02 | 7.871e-03 | 1.823e-02 |
| 5.000e-01 | 2.370e-02 | 1.252e-02 | 2.869e-02 |
| 7.000e-01 | 3.098e-02 | 1.667e-02 | 3.776e-02 |
| 9.000e-01 | 3.700e-02 | 2.026e-02 | 4.544e-02 |
| 1.100e+00 | 4.175e-02 | 2.324e-02 | 5.171e-02 |
| 1.300e+00 | 4.531e-02 | 2.553e-02 | 5.660e-02 |
| 1.500e+00 | 4.779e-02 | 2.709e-02 | 6.023e-02 |
| 1.700e+00 | 4.935e-02 | 2.803e-02 | 6.271e-02 |
| 1.900e+00 | 5.013e-02 | 2.851e-02 | 6.419e-02 |
| 2.100e+00 | 5.046e-02 | 2.876e-02 | 6.494e-02 |
| 2.300e+00 | 5.063e-02 | 2.892e-02 | 6.525e-02 |
| 2.500e+00 | 5.075e-02 | 2.904e-02 | 6.540e-02 |
| 2.700e+00 | 5.085e-02 | 2.912e-02 | 6.549e-02 |
| 2.900e+00 | 5.090e-02 | 2.876e-02 | 6.555e-02 |
| 3.100e+00 | 4.771e-02 | 2.994e-02 | 6.561e-02 |
| 3.300e+00 | 4.525e-02 | 3.321e-02 | 6.182e-02 |
| 3.500e+00 | 4.657e-02 | 3.570e-02 | 6.049e-02 |
| 3.700e+00 | 4.904e-02 | 3.801e-02 | 6.178e-02 |
| 3.900e+00 | 5.221e-02 | 4.029e-02 | 6.450e-02 |
| 4.100e+00 | 5.524e-02 | 4.253e-02 | 6.659e-02 |
| 4.300e+00 | 5.634e-02 | 4.463e-02 | 6.867e-02 |
| 4.500e+00 | 5.751e-02 | 4.645e-02 | 6.970e-02 |
| 4.700e+00 | 5.634e-02 | 4.786e-02 | 6.938e-02 |
| 4.900e+00 | 5.648e-02 | 4.881e-02 | 6.960e-02 |
| 5.100e+00 | 5.664e-02 | 4.912e-02 | 6.983e-02 |
| 5.300e+00 | 5.679e-02 | 4.795e-02 | 7.005e-02 |
| 5.500e+00 | 5.693e-02 | 4.679e-02 | 7.026e-02 |
| 5.700e+00 | 5.707e-02 | 4.688e-02 | 7.049e-02 |
| 5.900e+00 | 5.722e-02 | 4.700e-02 | 7.074e-02 |
| 6.100e+00 | 5.741e-02 | 4.712e-02 | 7.105e-02 |
| 6.300e+00 | 5.766e-02 | 4.723e-02 | 7.147e-02 |
| 6.500e+00 | 5.801e-02 | 4.733e-02 | 7.205e-02 |
| 6.600e+00 | 5.824e-02 | 4.737e-02 | 7.242e-02 |
| | | | |
| [Pullup] | | | |
| voltage | I (typ) | I (min) | I (max) |
| | | | |
| -3.30e+00 | 2.922e-04 | 2.177e-04 | 4.123e-04 |
| -3.10e+00 | 2.881e-04 | 2.175e-04 | 4.021e-04 |
| -2.90e+00 | 2.853e-04 | 2.173e-04 | 3.946e-04 |
| -2.70e+00 | 2.836e-04 | 2.172e-04 | 3.893e-04 |
| -2.50e+00 | 2.825e-04 | 2.171e-04 | 3.857e-04 |
| -2.30e+00 | 2.819e-04 | 2.170e-04 | 3.834e-04 |
| -2.10e+00 | 2.815e-04 | 2.169e-04 | 3.820e-04 |
| -1.90e+00 | 2.813e-04 | 2.167e-04 | 3.812e-04 |
| -1.70e+00 | 2.812e-04 | 2.520e-04 | 3.808e-04 |

| | | | |
|-------------|-----------|-----------|-----------|
| -1.50e+00 | 2.811e-04 | 3.078e-02 | 3.806e-04 |
| -1.30e+00 | 2.810e-04 | 2.684e-02 | 3.804e-04 |
| -1.10e+00 | 2.809e-04 | 2.277e-02 | 3.802e-04 |
| -9.00e-01 | 2.808e-04 | 1.864e-02 | 3.801e-04 |
| -7.00e-01 | 2.997e-04 | 1.447e-02 | 3.799e-04 |
| -5.00e-01 | 1.750e-02 | 1.031e-02 | 3.797e-04 |
| -3.00e-01 | 1.048e-02 | 6.181e-03 | 3.776e-04 |
| -1.00e-01 | 3.487e-03 | 2.084e-03 | 4.568e-03 |
| 1.000e-01 | -3.40e-03 | -2.03e-03 | -4.22e-03 |
| 3.000e-01 | -9.69e-03 | -5.71e-03 | -1.24e-02 |
| 5.000e-01 | -1.52e-02 | -8.99e-03 | -1.95e-02 |
| 7.000e-01 | -2.02e-02 | -1.19e-02 | -2.61e-02 |
| 9.000e-01 | -2.46e-02 | -1.43e-02 | -3.21e-02 |
| 1.100e+00 | -2.84e-02 | -1.62e-02 | -3.73e-02 |
| 1.300e+00 | -3.14e-02 | -1.77e-02 | -4.18e-02 |
| 1.500e+00 | -3.37e-02 | -1.88e-02 | -4.55e-02 |
| 1.700e+00 | -3.55e-02 | -1.95e-02 | -4.85e-02 |
| 1.900e+00 | -3.68e-02 | -2.00e-02 | -5.09e-02 |
| 2.100e+00 | -3.78e-02 | -2.04e-02 | -5.27e-02 |
| 2.300e+00 | -3.85e-02 | -2.07e-02 | -5.41e-02 |
| 2.500e+00 | -3.91e-02 | -2.10e-02 | -5.51e-02 |
| 2.700e+00 | -3.96e-02 | -2.12e-02 | -5.60e-02 |
| 2.900e+00 | -4.01e-02 | -2.15e-02 | -5.67e-02 |
| 3.100e+00 | -4.04e-02 | -2.17e-02 | -5.74e-02 |
| 3.300e+00 | -4.08e-02 | -2.18e-02 | -5.79e-02 |
| 3.500e+00 | -4.11e-02 | -2.20e-02 | -5.84e-02 |
| 3.700e+00 | -4.14e-02 | -2.78e-02 | -5.89e-02 |
| 3.900e+00 | -4.17e-02 | -1.20e+00 | -5.94e-02 |
| 4.100e+00 | -4.32e-02 | -2.15e+01 | -5.98e-02 |
| 4.300e+00 | -4.08e-01 | -4.52e+01 | -6.10e-02 |
| 4.500e+00 | -2.73e+01 | -6.89e+01 | -6.84e-02 |
| 4.700e+00 | -6.13e+01 | -9.25e+01 | -7.73e+00 |
| 4.900e+00 | -9.54e+01 | -1.17e+02 | -4.18e+01 |
| 5.100e+00 | -1.38e+02 | -1.52e+02 | -7.59e+01 |
| 5.300e+00 | -1.89e+02 | -1.88e+02 | -1.11e+02 |
| 5.500e+00 | -2.40e+02 | -2.23e+02 | -1.61e+02 |
| 5.700e+00 | -2.91e+02 | -2.59e+02 | -2.12e+02 |
| 5.900e+00 | -3.42e+02 | -2.94e+02 | -2.63e+02 |
| 6.100e+00 | -3.93e+02 | -3.30e+02 | -3.14e+02 |
| 6.300e+00 | -4.44e+02 | -3.65e+02 | -3.65e+02 |
| 6.500e+00 | -4.95e+02 | -4.01e+02 | -4.16e+02 |
| 6.600e+00 | -5.21e+02 | -4.18e+02 | -4.41e+02 |
| | | | |
| [GND_clamp] | | | |
| voltage | I (typ) | I (min) | I (max) |
| | | | |
| -3.30e+00 | -5.21e+02 | -3.65e+02 | -5.18e+02 |
| -3.10e+00 | -4.69e+02 | -3.30e+02 | -4.67e+02 |
| -2.90e+00 | -4.18e+02 | -2.94e+02 | -4.16e+02 |
| -2.70e+00 | -3.67e+02 | -2.59e+02 | -3.65e+02 |
| -2.50e+00 | -3.16e+02 | -2.23e+02 | -3.14e+02 |
| -2.30e+00 | -2.65e+02 | -1.88e+02 | -2.63e+02 |
| -2.10e+00 | -2.14e+02 | -1.52e+02 | -2.12e+02 |
| -1.90e+00 | -1.63e+02 | -1.17e+02 | -1.61e+02 |
| -1.70e+00 | -1.13e+02 | -9.25e+01 | -1.10e+02 |

```

-1.50e+00  -7.83e+01  -6.88e+01  -7.58e+01
-1.30e+00  -4.43e+01  -4.52e+01  -4.17e+01
-1.10e+00  -1.02e+01  -2.15e+01  -7.67e+00
-9.00e-01  -9.69e-03  -1.18e+00  -7.81e-03
-7.00e-01  -2.83e-04  -5.70e-03  -8.42e-04
-5.00e-01  -1.35e-06  -4.53e-05  -1.00e-05
-3.00e-01  -1.31e-09  -3.74e-07  -8.58e-09
-1.00e-01  -2.92e-11  -3.00e-09  -3.64e-11
0.000e+00  -2.44e-11  -5.14e-10  -2.79e-11
|
[Ramp]
R_load = 50.00
|voltage      I (typ)      I (min)      I (max)
|
|
dV/dt_r      1.030/0.465    0.605/0.676    1.320/0.366
|
|
dV/dt_f      1.290/0.671    0.829/0.122    1.520/0.431
|
|
[Model]      ip5b_o
Model_type   3-state
Polarity     Non-Inverting
C_comp      5.00pF      5.00pF      5.00pF
|
|
[Voltage Range]  3.3v      3v      3.6v
[Pulldown]
|voltage      I (typ)      I (min)      I (max)
|
-3.30e+00  -5.21e+02  -3.65e+02  -5.18e+02
-3.10e+00  -4.69e+02  -3.30e+02  -4.67e+02
-2.90e+00  -4.18e+02  -2.94e+02  -4.16e+02
-2.70e+00  -3.67e+02  -2.59e+02  -3.65e+02
-2.50e+00  -3.16e+02  -2.23e+02  -3.14e+02
-2.30e+00  -2.65e+02  -1.88e+02  -2.63e+02
-2.10e+00  -2.14e+02  -1.52e+02  -2.12e+02
-1.90e+00  -1.63e+02  -1.17e+02  -1.61e+02
-1.70e+00  -1.13e+02  -9.25e+01  -1.10e+02
-1.50e+00  -7.83e+01  -6.88e+01  -7.58e+01
-1.30e+00  -4.43e+01  -4.52e+01  -4.17e+01
-1.10e+00  -1.02e+01  -2.15e+01  -7.69e+00
-9.00e-01  -5.10e-02  -1.18e+00  -5.63e-02
-7.00e-01  -3.65e-02  -2.25e-02  -4.28e-02
-5.00e-01  -2.65e-02  -1.38e-02  -3.12e-02
-3.00e-01  -1.62e-02  -8.35e-03  -1.91e-02
-1.00e-01  -5.49e-03  -2.80e-03  -6.52e-03
1.000e-01  5.377e-03  2.744e-03  6.427e-03
3.000e-01  1.516e-02  7.871e-03  1.823e-02
5.000e-01  2.370e-02  1.252e-02  2.869e-02
7.000e-01  3.098e-02  1.667e-02  3.776e-02
9.000e-01  3.700e-02  2.026e-02  4.544e-02
1.100e+00  4.175e-02  2.324e-02  5.171e-02
1.300e+00  4.531e-02  2.553e-02  5.660e-02

```

| | | | |
|-----------|-----------|-----------|-----------|
| 1.500e+00 | 4.779e-02 | 2.709e-02 | 6.023e-02 |
| 1.700e+00 | 4.935e-02 | 2.803e-02 | 6.271e-02 |
| 1.900e+00 | 5.013e-02 | 2.851e-02 | 6.419e-02 |
| 2.100e+00 | 5.046e-02 | 2.876e-02 | 6.494e-02 |
| 2.300e+00 | 5.063e-02 | 2.892e-02 | 6.525e-02 |
| 2.500e+00 | 5.075e-02 | 2.904e-02 | 6.540e-02 |
| 2.700e+00 | 5.085e-02 | 2.912e-02 | 6.549e-02 |
| 2.900e+00 | 5.090e-02 | 2.876e-02 | 6.555e-02 |
| 3.100e+00 | 4.771e-02 | 2.994e-02 | 6.561e-02 |
| 3.300e+00 | 4.525e-02 | 3.321e-02 | 6.182e-02 |
| 3.500e+00 | 4.657e-02 | 3.570e-02 | 6.049e-02 |
| 3.700e+00 | 4.904e-02 | 3.801e-02 | 6.178e-02 |
| 3.900e+00 | 5.221e-02 | 4.029e-02 | 6.450e-02 |
| 4.100e+00 | 5.524e-02 | 4.253e-02 | 6.659e-02 |
| 4.300e+00 | 5.634e-02 | 4.463e-02 | 6.867e-02 |
| 4.500e+00 | 5.751e-02 | 4.645e-02 | 6.970e-02 |
| 4.700e+00 | 5.634e-02 | 4.786e-02 | 6.938e-02 |
| 4.900e+00 | 5.648e-02 | 4.881e-02 | 6.960e-02 |
| 5.100e+00 | 5.664e-02 | 4.912e-02 | 6.983e-02 |
| 5.300e+00 | 5.679e-02 | 4.795e-02 | 7.005e-02 |
| 5.500e+00 | 5.693e-02 | 4.679e-02 | 7.026e-02 |
| 5.700e+00 | 5.707e-02 | 4.688e-02 | 7.049e-02 |
| 5.900e+00 | 5.722e-02 | 4.700e-02 | 7.074e-02 |
| 6.100e+00 | 5.741e-02 | 4.712e-02 | 7.105e-02 |
| 6.300e+00 | 5.766e-02 | 4.723e-02 | 7.147e-02 |
| 6.500e+00 | 5.801e-02 | 4.733e-02 | 7.205e-02 |
| 6.600e+00 | 5.824e-02 | 4.737e-02 | 7.242e-02 |
| | | | |
| [Pullup] | | | |
| voltage | I (typ) | I (min) | I (max) |
| | | | |
| -3.30e+00 | 2.922e-04 | 2.177e-04 | 4.123e-04 |
| -3.10e+00 | 2.881e-04 | 2.175e-04 | 4.021e-04 |
| -2.90e+00 | 2.853e-04 | 2.173e-04 | 3.946e-04 |
| -2.70e+00 | 2.836e-04 | 2.172e-04 | 3.893e-04 |
| -2.50e+00 | 2.825e-04 | 2.171e-04 | 3.857e-04 |
| -2.30e+00 | 2.819e-04 | 2.170e-04 | 3.834e-04 |
| -2.10e+00 | 2.815e-04 | 2.169e-04 | 3.820e-04 |
| -1.90e+00 | 2.813e-04 | 2.167e-04 | 3.812e-04 |
| -1.70e+00 | 2.812e-04 | 2.520e-04 | 3.808e-04 |
| -1.50e+00 | 2.811e-04 | 3.078e-02 | 3.806e-04 |
| -1.30e+00 | 2.810e-04 | 2.684e-02 | 3.804e-04 |
| -1.10e+00 | 2.809e-04 | 2.277e-02 | 3.802e-04 |
| -9.00e-01 | 2.808e-04 | 1.864e-02 | 3.801e-04 |
| -7.00e-01 | 2.997e-04 | 1.447e-02 | 3.799e-04 |
| -5.00e-01 | 1.750e-02 | 1.031e-02 | 3.797e-04 |
| -3.00e-01 | 1.048e-02 | 6.181e-03 | 3.776e-04 |
| -1.00e-01 | 3.487e-03 | 2.084e-03 | 4.568e-03 |
| 1.000e-01 | -3.40e-03 | -2.03e-03 | -4.22e-03 |
| 3.000e-01 | -9.69e-03 | -5.71e-03 | -1.24e-02 |
| 5.000e-01 | -1.52e-02 | -8.99e-03 | -1.95e-02 |
| 7.000e-01 | -2.02e-02 | -1.19e-02 | -2.61e-02 |
| 9.000e-01 | -2.46e-02 | -1.43e-02 | -3.21e-02 |
| 1.100e+00 | -2.84e-02 | -1.62e-02 | -3.73e-02 |
| 1.300e+00 | -3.14e-02 | -1.77e-02 | -4.18e-02 |

| | | | |
|----------------|-----------|-----------|-----------|
| 1.500e+00 | -3.37e-02 | -1.88e-02 | -4.55e-02 |
| 1.700e+00 | -3.55e-02 | -1.95e-02 | -4.85e-02 |
| 1.900e+00 | -3.68e-02 | -2.00e-02 | -5.09e-02 |
| 2.100e+00 | -3.78e-02 | -2.04e-02 | -5.27e-02 |
| 2.300e+00 | -3.85e-02 | -2.07e-02 | -5.41e-02 |
| 2.500e+00 | -3.91e-02 | -2.10e-02 | -5.51e-02 |
| 2.700e+00 | -3.96e-02 | -2.12e-02 | -5.60e-02 |
| 2.900e+00 | -4.01e-02 | -2.15e-02 | -5.67e-02 |
| 3.100e+00 | -4.04e-02 | -2.17e-02 | -5.74e-02 |
| 3.300e+00 | -4.08e-02 | -2.18e-02 | -5.79e-02 |
| 3.500e+00 | -4.11e-02 | -2.20e-02 | -5.84e-02 |
| 3.700e+00 | -4.14e-02 | -2.78e-02 | -5.89e-02 |
| 3.900e+00 | -4.17e-02 | -1.20e+00 | -5.94e-02 |
| 4.100e+00 | -4.32e-02 | -2.15e+01 | -5.98e-02 |
| 4.300e+00 | -4.08e-01 | -4.52e+01 | -6.10e-02 |
| 4.500e+00 | -2.73e+01 | -6.89e+01 | -6.84e-02 |
| 4.700e+00 | -6.13e+01 | -9.25e+01 | -7.73e+00 |
| 4.900e+00 | -9.54e+01 | -1.17e+02 | -4.18e+01 |
| 5.100e+00 | -1.38e+02 | -1.52e+02 | -7.59e+01 |
| 5.300e+00 | -1.89e+02 | -1.88e+02 | -1.11e+02 |
| 5.500e+00 | -2.40e+02 | -2.23e+02 | -1.61e+02 |
| 5.700e+00 | -2.91e+02 | -2.59e+02 | -2.12e+02 |
| 5.900e+00 | -3.42e+02 | -2.94e+02 | -2.63e+02 |
| 6.100e+00 | -3.93e+02 | -3.30e+02 | -3.14e+02 |
| 6.300e+00 | -4.44e+02 | -3.65e+02 | -3.65e+02 |
| 6.500e+00 | -4.95e+02 | -4.01e+02 | -4.16e+02 |
| 6.600e+00 | -5.21e+02 | -4.18e+02 | -4.41e+02 |
| | | | |
| [GND_clamp] | | | |
| voltage | I (typ) | I (min) | I (max) |
| | | | |
| -3.30e+00 | -5.21e+02 | -3.65e+02 | -5.18e+02 |
| -3.10e+00 | -4.69e+02 | -3.30e+02 | -4.67e+02 |
| -2.90e+00 | -4.18e+02 | -2.94e+02 | -4.16e+02 |
| -2.70e+00 | -3.67e+02 | -2.59e+02 | -3.65e+02 |
| -2.50e+00 | -3.16e+02 | -2.23e+02 | -3.14e+02 |
| -2.30e+00 | -2.65e+02 | -1.88e+02 | -2.63e+02 |
| -2.10e+00 | -2.14e+02 | -1.52e+02 | -2.12e+02 |
| -1.90e+00 | -1.63e+02 | -1.17e+02 | -1.61e+02 |
| -1.70e+00 | -1.13e+02 | -9.25e+01 | -1.10e+02 |
| -1.50e+00 | -7.83e+01 | -6.88e+01 | -7.58e+01 |
| -1.30e+00 | -4.43e+01 | -4.52e+01 | -4.17e+01 |
| -1.10e+00 | -1.02e+01 | -2.15e+01 | -7.67e+00 |
| -9.00e-01 | -9.69e-03 | -1.18e+00 | -7.81e-03 |
| -7.00e-01 | -2.83e-04 | -5.70e-03 | -8.42e-04 |
| -5.00e-01 | -1.35e-06 | -4.53e-05 | -1.00e-05 |
| -3.00e-01 | -1.31e-09 | -3.74e-07 | -8.58e-09 |
| -1.00e-01 | -2.92e-11 | -3.00e-09 | -3.64e-11 |
| 0.000e+00 | -2.44e-11 | -5.14e-10 | -2.79e-11 |
| | | | |
| [Ramp] | | | |
| R_load = 50.00 | | | |
| voltage | I (typ) | I (min) | I (max) |
| | | | |
| | | | |

```

dV/dt_r      1.030/0.465    0.605/0.676    1.320/0.366
|
|
dV/dt_f      1.290/0.671    0.829/0.122    1.520/0.431
|
|
[Model]      icba_io
Model_type   I/O
Polarity     Non-Inverting
Vinl= 0.8000v
Vinh= 2.000v
C_comp      5.00pF      5.00pF      5.00pF
|
|
[Voltage Range]  3.3v      3v      3.6v
[Pulldown]
|voltage      I (typ)      I (min)      I (max)
|
-3.30e+00    -5.20e+02    -3.65e+02    -5.18e+02
-3.10e+00    -4.69e+02    -3.30e+02    -4.67e+02
-2.90e+00    -4.18e+02    -2.94e+02    -4.16e+02
-2.70e+00    -3.67e+02    -2.59e+02    -3.65e+02
-2.50e+00    -3.16e+02    -2.23e+02    -3.14e+02
-2.30e+00    -2.65e+02    -1.88e+02    -2.63e+02
-2.10e+00    -2.14e+02    -1.52e+02    -2.12e+02
-1.90e+00    -1.63e+02    -1.17e+02    -1.60e+02
-1.70e+00    -1.13e+02    -9.25e+01    -1.10e+02
-1.50e+00    -7.83e+01    -6.88e+01    -7.58e+01
-1.30e+00    -4.43e+01    -4.52e+01    -4.17e+01
-1.10e+00    -1.02e+01    -2.15e+01    -7.68e+00
-9.00e-01    -2.70e-02    -1.19e+00    -2.90e-02
-7.00e-01    -1.32e-02    -1.25e-02    -1.63e-02
-5.00e-01    -9.33e-03    -4.69e-03    -1.10e-02
-3.00e-01    -5.75e-03    -2.81e-03    -6.76e-03
-1.00e-01    -1.97e-03    -9.48e-04    -2.32e-03
1.000e-01    1.945e-03    9.285e-04    2.307e-03
3.000e-01    5.507e-03    2.640e-03    6.599e-03
5.000e-01    8.649e-03    4.168e-03    1.048e-02
7.000e-01    1.136e-02    5.504e-03    1.393e-02
9.000e-01    1.364e-02    6.636e-03    1.693e-02
1.100e+00    1.547e-02    7.551e-03    1.950e-02
1.300e+00    1.688e-02    8.240e-03    2.162e-02
1.500e+00    1.299e-01    6.458e-02    2.331e-02
1.700e+00    1.366e-01    6.746e-02    1.755e-01
1.900e+00    1.404e-01    6.916e-02    1.847e-01
2.100e+00    1.423e-01    7.006e-02    1.907e-01
2.300e+00    1.433e-01    7.059e-02    1.940e-01
2.500e+00    1.440e-01    7.098e-02    1.958e-01
2.700e+00    1.445e-01    7.128e-02    1.970e-01
2.900e+00    1.450e-01    7.154e-02    1.979e-01
3.100e+00    1.454e-01    7.176e-02    1.986e-01
3.300e+00    1.458e-01    7.196e-02    1.993e-01
3.500e+00    1.461e-01    7.223e-02    1.999e-01
3.700e+00    1.464e-01    8.810e-02    2.004e-01
3.900e+00    1.469e-01    2.589e+00    2.009e-01

```

| | | | |
|-----------|-----------|-----------|-----------|
| 4.100e+00 | 1.490e-01 | 1.451e+01 | 2.015e-01 |
| 4.300e+00 | 1.501e+00 | 2.658e+01 | 2.030e-01 |
| 4.500e+00 | 1.813e+01 | 3.866e+01 | 2.385e-01 |
| 4.700e+00 | 3.540e+01 | 5.076e+01 | 9.563e+00 |
| 4.900e+00 | 5.269e+01 | 6.461e+01 | 2.682e+01 |
| 5.100e+00 | 7.541e+01 | 8.261e+01 | 4.409e+01 |
| 5.300e+00 | 1.012e+02 | 1.006e+02 | 6.258e+01 |
| 5.500e+00 | 1.270e+02 | 1.186e+02 | 8.836e+01 |
| 5.700e+00 | 1.527e+02 | 1.366e+02 | 1.141e+02 |
| 5.900e+00 | 1.785e+02 | 1.546e+02 | 1.399e+02 |
| 6.100e+00 | 2.043e+02 | 1.726e+02 | 1.657e+02 |
| 6.300e+00 | 2.301e+02 | 1.906e+02 | 1.915e+02 |
| 6.500e+00 | 2.559e+02 | 2.086e+02 | 2.173e+02 |
| 6.600e+00 | 2.688e+02 | 2.176e+02 | 2.302e+02 |
| | | | |
| [Pullup] | | | |
| voltage | I (typ) | I (min) | I (max) |
| | | | |
| -3.30e+00 | 2.686e+02 | 1.905e+02 | 2.686e+02 |
| -3.10e+00 | 2.428e+02 | 1.725e+02 | 2.428e+02 |
| -2.90e+00 | 2.170e+02 | 1.545e+02 | 2.170e+02 |
| -2.70e+00 | 1.912e+02 | 1.365e+02 | 1.912e+02 |
| -2.50e+00 | 1.655e+02 | 1.185e+02 | 1.655e+02 |
| -2.30e+00 | 1.397e+02 | 1.005e+02 | 1.397e+02 |
| -2.10e+00 | 1.139e+02 | 8.253e+01 | 1.139e+02 |
| -1.90e+00 | 8.814e+01 | 6.454e+01 | 8.814e+01 |
| -1.70e+00 | 6.237e+01 | 5.068e+01 | 6.237e+01 |
| -1.50e+00 | 4.389e+01 | 3.859e+01 | 4.389e+01 |
| -1.30e+00 | 2.662e+01 | 2.651e+01 | 2.662e+01 |
| -1.10e+00 | 9.360e+00 | 1.444e+01 | 9.362e+00 |
| -9.00e-01 | 4.275e-02 | 2.518e+00 | 4.663e-02 |
| -7.00e-01 | 8.208e-03 | 2.012e-02 | 1.070e-02 |
| -5.00e-01 | 5.635e-03 | 3.518e-03 | 7.068e-03 |
| -3.00e-01 | 3.370e-03 | 2.053e-03 | 4.233e-03 |
| -1.00e-01 | 1.118e-03 | 6.789e-04 | 1.410e-03 |
| 1.000e-01 | -1.09e-03 | -6.56e-04 | -1.38e-03 |
| 3.000e-01 | -3.12e-03 | -1.86e-03 | -3.99e-03 |
| 5.000e-01 | -4.96e-03 | -2.93e-03 | -6.39e-03 |
| 7.000e-01 | -6.60e-03 | -3.87e-03 | -8.59e-03 |
| 9.000e-01 | -8.04e-03 | -4.66e-03 | -1.06e-02 |
| 1.100e+00 | -9.26e-03 | -5.30e-03 | -1.23e-02 |
| 1.300e+00 | -1.03e-02 | -6.55e-03 | -1.38e-02 |
| 1.500e+00 | -1.25e-01 | -6.93e-02 | -1.70e-01 |
| 1.700e+00 | -1.31e-01 | -7.19e-02 | -1.82e-01 |
| 1.900e+00 | -1.36e-01 | -7.38e-02 | -1.91e-01 |
| 2.100e+00 | -1.40e-01 | -7.53e-02 | -1.97e-01 |
| 2.300e+00 | -1.42e-01 | -7.65e-02 | -2.03e-01 |
| 2.500e+00 | -1.44e-01 | -7.76e-02 | -2.07e-01 |
| 2.700e+00 | -1.46e-01 | -7.85e-02 | -2.10e-01 |
| 2.900e+00 | -1.48e-01 | -7.93e-02 | -2.13e-01 |
| 3.100e+00 | -1.49e-01 | -8.00e-02 | -2.15e-01 |
| 3.300e+00 | -1.50e-01 | -8.06e-02 | -2.17e-01 |
| 3.500e+00 | -1.52e-01 | -8.13e-02 | -2.19e-01 |
| 3.700e+00 | -1.53e-01 | -8.84e-02 | -2.21e-01 |
| 3.900e+00 | -1.54e-01 | -1.26e+00 | -2.22e-01 |

| | | | |
|---------------|-----------|-----------|-----------|
| 4.100e+00 | -1.57e-01 | -2.16e+01 | -2.24e-01 |
| 4.300e+00 | -5.25e-01 | -4.53e+01 | -2.27e-01 |
| 4.500e+00 | -2.74e+01 | -6.89e+01 | -2.38e-01 |
| 4.700e+00 | -6.14e+01 | -9.26e+01 | -7.90e+00 |
| 4.900e+00 | -9.55e+01 | -1.17e+02 | -4.20e+01 |
| 5.100e+00 | -1.38e+02 | -1.52e+02 | -7.60e+01 |
| 5.300e+00 | -1.89e+02 | -1.88e+02 | -1.11e+02 |
| 5.500e+00 | -2.40e+02 | -2.23e+02 | -1.61e+02 |
| 5.700e+00 | -2.91e+02 | -2.59e+02 | -2.12e+02 |
| 5.900e+00 | -3.42e+02 | -2.94e+02 | -2.63e+02 |
| 6.100e+00 | -3.93e+02 | -3.30e+02 | -3.14e+02 |
| 6.300e+00 | -4.44e+02 | -3.65e+02 | -3.65e+02 |
| 6.500e+00 | -4.95e+02 | -4.01e+02 | -4.16e+02 |
| 6.600e+00 | -5.21e+02 | -4.19e+02 | -4.42e+02 |
| | | | |
| [GND_clamp] | | | |
| voltage | I (typ) | I (min) | I (max) |
| | | | |
| -3.30e+00 | -5.20e+02 | -3.65e+02 | -5.18e+02 |
| -3.10e+00 | -4.69e+02 | -3.30e+02 | -4.67e+02 |
| -2.90e+00 | -4.18e+02 | -2.94e+02 | -4.16e+02 |
| -2.70e+00 | -3.67e+02 | -2.59e+02 | -3.65e+02 |
| -2.50e+00 | -3.16e+02 | -2.23e+02 | -3.14e+02 |
| -2.30e+00 | -2.65e+02 | -1.88e+02 | -2.63e+02 |
| -2.10e+00 | -2.14e+02 | -1.52e+02 | -2.12e+02 |
| -1.90e+00 | -1.63e+02 | -1.17e+02 | -1.60e+02 |
| -1.70e+00 | -1.13e+02 | -9.25e+01 | -1.10e+02 |
| -1.50e+00 | -7.83e+01 | -6.88e+01 | -7.58e+01 |
| -1.30e+00 | -4.43e+01 | -4.52e+01 | -4.17e+01 |
| -1.10e+00 | -1.02e+01 | -2.15e+01 | -7.67e+00 |
| -9.00e-01 | -1.22e-02 | -1.18e+00 | -1.17e-02 |
| -7.00e-01 | -5.18e-04 | -6.62e-03 | -1.56e-03 |
| -5.00e-01 | -2.43e-06 | -6.64e-05 | -1.80e-05 |
| -3.00e-01 | -2.33e-09 | -6.35e-07 | -1.54e-08 |
| -1.00e-01 | -2.10e-11 | -6.31e-09 | -2.99e-11 |
| 0.000e+00 | -1.70e-11 | -1.95e-09 | -1.91e-11 |
| | | | |
| [POWER_clamp] | | | |
| voltage | I (typ) | I (min) | I (max) |
| | | | |
| -3.30e+00 | 2.686e+02 | 1.905e+02 | 2.686e+02 |
| -3.10e+00 | 2.428e+02 | 1.725e+02 | 2.428e+02 |
| -2.90e+00 | 2.170e+02 | 1.545e+02 | 2.170e+02 |
| -2.70e+00 | 1.912e+02 | 1.365e+02 | 1.912e+02 |
| -2.50e+00 | 1.655e+02 | 1.185e+02 | 1.655e+02 |
| -2.30e+00 | 1.397e+02 | 1.005e+02 | 1.397e+02 |
| -2.10e+00 | 1.139e+02 | 8.253e+01 | 1.139e+02 |
| -1.90e+00 | 8.814e+01 | 6.454e+01 | 8.814e+01 |
| -1.70e+00 | 6.236e+01 | 5.068e+01 | 6.237e+01 |
| -1.50e+00 | 4.389e+01 | 3.859e+01 | 4.389e+01 |
| -1.30e+00 | 2.662e+01 | 2.651e+01 | 2.662e+01 |
| -1.10e+00 | 9.358e+00 | 1.444e+01 | 9.359e+00 |
| -9.00e-01 | 3.399e-02 | 2.517e+00 | 3.554e-02 |
| -7.00e-01 | 3.426e-04 | 1.577e-02 | 9.211e-04 |
| -5.00e-01 | 2.840e-06 | 7.857e-05 | 1.655e-05 |

```

-3.00e-01  3.401e-09  6.836e-07  1.946e-08
-1.00e-01  6.162e-11  7.379e-09  7.622e-11
0.000e+00  5.758e-11  2.438e-09  6.240e-11
|
[Ramp]
R_load = 50.00
|voltage          I (typ)          I (min)          I (max)
|
|
dV/dt_r          1.680/0.164      1.360/0.329      1.900/0.124
|
|
dV/dt_f          1.690/0.219      1.310/0.442      1.880/0.155
|
|
[Model]          icba_o
Model_type       3-state
Polarity         Non-Inverting
C_comp           5.00pF           5.00pF           5.00pF
|
|
[Voltage Range]  3.3v            3v               3.6v
[Pulldown]
|voltage          I (typ)          I (min)          I (max)
|
-3.30e+00  -5.20e+02  -3.65e+02  -5.18e+02
-3.10e+00  -4.69e+02  -3.30e+02  -4.67e+02
-2.90e+00  -4.18e+02  -2.94e+02  -4.16e+02
-2.70e+00  -3.67e+02  -2.59e+02  -3.65e+02
-2.50e+00  -3.16e+02  -2.23e+02  -3.14e+02
-2.30e+00  -2.65e+02  -1.88e+02  -2.63e+02
-2.10e+00  -2.14e+02  -1.52e+02  -2.12e+02
-1.90e+00  -1.63e+02  -1.17e+02  -1.60e+02
-1.70e+00  -1.13e+02  -9.25e+01  -1.10e+02
-1.50e+00  -7.83e+01  -6.88e+01  -7.58e+01
-1.30e+00  -4.43e+01  -4.52e+01  -4.17e+01
-1.10e+00  -1.02e+01  -2.15e+01  -7.68e+00
-9.00e-01  -2.70e-02  -1.19e+00  -2.90e-02
-7.00e-01  -1.32e-02  -1.25e-02  -1.63e-02
-5.00e-01  -9.33e-03  -4.69e-03  -1.10e-02
-3.00e-01  -5.75e-03  -2.81e-03  -6.76e-03
-1.00e-01  -1.97e-03  -9.48e-04  -2.32e-03
1.000e-01  1.945e-03  9.285e-04  2.307e-03
3.000e-01  5.507e-03  2.640e-03  6.599e-03
5.000e-01  8.649e-03  4.168e-03  1.048e-02
7.000e-01  1.136e-02  5.504e-03  1.393e-02
9.000e-01  1.364e-02  6.636e-03  1.693e-02
1.100e+00  1.547e-02  7.551e-03  1.950e-02
1.300e+00  1.688e-02  8.240e-03  2.162e-02
1.500e+00  1.299e-01  6.458e-02  2.331e-02
1.700e+00  1.366e-01  6.746e-02  1.755e-01
1.900e+00  1.404e-01  6.916e-02  1.847e-01
2.100e+00  1.423e-01  7.006e-02  1.907e-01
2.300e+00  1.433e-01  7.059e-02  1.940e-01
2.500e+00  1.440e-01  7.098e-02  1.958e-01

```

| | | | |
|-----------|-----------|-----------|-----------|
| 2.700e+00 | 1.445e-01 | 7.128e-02 | 1.970e-01 |
| 2.900e+00 | 1.450e-01 | 7.154e-02 | 1.979e-01 |
| 3.100e+00 | 1.454e-01 | 7.176e-02 | 1.986e-01 |
| 3.300e+00 | 1.458e-01 | 7.196e-02 | 1.993e-01 |
| 3.500e+00 | 1.461e-01 | 7.223e-02 | 1.999e-01 |
| 3.700e+00 | 1.464e-01 | 8.810e-02 | 2.004e-01 |
| 3.900e+00 | 1.469e-01 | 2.589e+00 | 2.009e-01 |
| 4.100e+00 | 1.490e-01 | 1.451e+01 | 2.015e-01 |
| 4.300e+00 | 1.501e+00 | 2.658e+01 | 2.030e-01 |
| 4.500e+00 | 1.813e+01 | 3.866e+01 | 2.385e-01 |
| 4.700e+00 | 3.540e+01 | 5.076e+01 | 9.563e+00 |
| 4.900e+00 | 5.269e+01 | 6.461e+01 | 2.682e+01 |
| 5.100e+00 | 7.541e+01 | 8.261e+01 | 4.409e+01 |
| 5.300e+00 | 1.012e+02 | 1.006e+02 | 6.258e+01 |
| 5.500e+00 | 1.270e+02 | 1.186e+02 | 8.836e+01 |
| 5.700e+00 | 1.527e+02 | 1.366e+02 | 1.141e+02 |
| 5.900e+00 | 1.785e+02 | 1.546e+02 | 1.399e+02 |
| 6.100e+00 | 2.043e+02 | 1.726e+02 | 1.657e+02 |
| 6.300e+00 | 2.301e+02 | 1.906e+02 | 1.915e+02 |
| 6.500e+00 | 2.559e+02 | 2.086e+02 | 2.173e+02 |
| 6.600e+00 | 2.688e+02 | 2.176e+02 | 2.302e+02 |
| | | | |
| [Pullup] | | | |
| voltage | I (typ) | I (min) | I (max) |
| | | | |
| -3.30e+00 | 2.686e+02 | 1.905e+02 | 2.686e+02 |
| -3.10e+00 | 2.428e+02 | 1.725e+02 | 2.428e+02 |
| -2.90e+00 | 2.170e+02 | 1.545e+02 | 2.170e+02 |
| -2.70e+00 | 1.912e+02 | 1.365e+02 | 1.912e+02 |
| -2.50e+00 | 1.655e+02 | 1.185e+02 | 1.655e+02 |
| -2.30e+00 | 1.397e+02 | 1.005e+02 | 1.397e+02 |
| -2.10e+00 | 1.139e+02 | 8.253e+01 | 1.139e+02 |
| -1.90e+00 | 8.814e+01 | 6.454e+01 | 8.814e+01 |
| -1.70e+00 | 6.237e+01 | 5.068e+01 | 6.237e+01 |
| -1.50e+00 | 4.389e+01 | 3.859e+01 | 4.389e+01 |
| -1.30e+00 | 2.662e+01 | 2.651e+01 | 2.662e+01 |
| -1.10e+00 | 9.360e+00 | 1.444e+01 | 9.362e+00 |
| -9.00e-01 | 4.275e-02 | 2.518e+00 | 4.663e-02 |
| -7.00e-01 | 8.208e-03 | 2.012e-02 | 1.070e-02 |
| -5.00e-01 | 5.635e-03 | 3.518e-03 | 7.068e-03 |
| -3.00e-01 | 3.370e-03 | 2.053e-03 | 4.233e-03 |
| -1.00e-01 | 1.118e-03 | 6.789e-04 | 1.410e-03 |
| 1.000e-01 | -1.09e-03 | -6.56e-04 | -1.38e-03 |
| 3.000e-01 | -3.12e-03 | -1.86e-03 | -3.99e-03 |
| 5.000e-01 | -4.96e-03 | -2.93e-03 | -6.39e-03 |
| 7.000e-01 | -6.60e-03 | -3.87e-03 | -8.59e-03 |
| 9.000e-01 | -8.04e-03 | -4.66e-03 | -1.06e-02 |
| 1.100e+00 | -9.26e-03 | -5.30e-03 | -1.23e-02 |
| 1.300e+00 | -1.03e-02 | -6.55e-03 | -1.38e-02 |
| 1.500e+00 | -1.25e-01 | -6.93e-02 | -1.70e-01 |
| 1.700e+00 | -1.31e-01 | -7.19e-02 | -1.82e-01 |
| 1.900e+00 | -1.36e-01 | -7.38e-02 | -1.91e-01 |
| 2.100e+00 | -1.40e-01 | -7.53e-02 | -1.97e-01 |
| 2.300e+00 | -1.42e-01 | -7.65e-02 | -2.03e-01 |
| 2.500e+00 | -1.44e-01 | -7.76e-02 | -2.07e-01 |

| | | | |
|---------------|-----------|-----------|-----------|
| 2.700e+00 | -1.46e-01 | -7.85e-02 | -2.10e-01 |
| 2.900e+00 | -1.48e-01 | -7.93e-02 | -2.13e-01 |
| 3.100e+00 | -1.49e-01 | -8.00e-02 | -2.15e-01 |
| 3.300e+00 | -1.50e-01 | -8.06e-02 | -2.17e-01 |
| 3.500e+00 | -1.52e-01 | -8.13e-02 | -2.19e-01 |
| 3.700e+00 | -1.53e-01 | -8.84e-02 | -2.21e-01 |
| 3.900e+00 | -1.54e-01 | -1.26e+00 | -2.22e-01 |
| 4.100e+00 | -1.57e-01 | -2.16e+01 | -2.24e-01 |
| 4.300e+00 | -5.25e-01 | -4.53e+01 | -2.27e-01 |
| 4.500e+00 | -2.74e+01 | -6.89e+01 | -2.38e-01 |
| 4.700e+00 | -6.14e+01 | -9.26e+01 | -7.90e+00 |
| 4.900e+00 | -9.55e+01 | -1.17e+02 | -4.20e+01 |
| 5.100e+00 | -1.38e+02 | -1.52e+02 | -7.60e+01 |
| 5.300e+00 | -1.89e+02 | -1.88e+02 | -1.11e+02 |
| 5.500e+00 | -2.40e+02 | -2.23e+02 | -1.61e+02 |
| 5.700e+00 | -2.91e+02 | -2.59e+02 | -2.12e+02 |
| 5.900e+00 | -3.42e+02 | -2.94e+02 | -2.63e+02 |
| 6.100e+00 | -3.93e+02 | -3.30e+02 | -3.14e+02 |
| 6.300e+00 | -4.44e+02 | -3.65e+02 | -3.65e+02 |
| 6.500e+00 | -4.95e+02 | -4.01e+02 | -4.16e+02 |
| 6.600e+00 | -5.21e+02 | -4.19e+02 | -4.42e+02 |
| | | | |
| [GND_clamp] | | | |
| voltage | I (typ) | I (min) | I (max) |
| | | | |
| -3.30e+00 | -5.20e+02 | -3.65e+02 | -5.18e+02 |
| -3.10e+00 | -4.69e+02 | -3.30e+02 | -4.67e+02 |
| -2.90e+00 | -4.18e+02 | -2.94e+02 | -4.16e+02 |
| -2.70e+00 | -3.67e+02 | -2.59e+02 | -3.65e+02 |
| -2.50e+00 | -3.16e+02 | -2.23e+02 | -3.14e+02 |
| -2.30e+00 | -2.65e+02 | -1.88e+02 | -2.63e+02 |
| -2.10e+00 | -2.14e+02 | -1.52e+02 | -2.12e+02 |
| -1.90e+00 | -1.63e+02 | -1.17e+02 | -1.60e+02 |
| -1.70e+00 | -1.13e+02 | -9.25e+01 | -1.10e+02 |
| -1.50e+00 | -7.83e+01 | -6.88e+01 | -7.58e+01 |
| -1.30e+00 | -4.43e+01 | -4.52e+01 | -4.17e+01 |
| -1.10e+00 | -1.02e+01 | -2.15e+01 | -7.67e+00 |
| -9.00e-01 | -1.22e-02 | -1.18e+00 | -1.17e-02 |
| -7.00e-01 | -5.18e-04 | -6.62e-03 | -1.56e-03 |
| -5.00e-01 | -2.43e-06 | -6.64e-05 | -1.80e-05 |
| -3.00e-01 | -2.33e-09 | -6.35e-07 | -1.54e-08 |
| -1.00e-01 | -2.10e-11 | -6.31e-09 | -2.99e-11 |
| 0.000e+00 | -1.70e-11 | -1.95e-09 | -1.91e-11 |
| | | | |
| [POWER_clamp] | | | |
| voltage | I (typ) | I (min) | I (max) |
| | | | |
| -3.30e+00 | 2.686e+02 | 1.905e+02 | 2.686e+02 |
| -3.10e+00 | 2.428e+02 | 1.725e+02 | 2.428e+02 |
| -2.90e+00 | 2.170e+02 | 1.545e+02 | 2.170e+02 |
| -2.70e+00 | 1.912e+02 | 1.365e+02 | 1.912e+02 |
| -2.50e+00 | 1.655e+02 | 1.185e+02 | 1.655e+02 |
| -2.30e+00 | 1.397e+02 | 1.005e+02 | 1.397e+02 |
| -2.10e+00 | 1.139e+02 | 8.253e+01 | 1.139e+02 |
| -1.90e+00 | 8.814e+01 | 6.454e+01 | 8.814e+01 |

```

-1.70e+00    6.236e+01    5.068e+01    6.237e+01
-1.50e+00    4.389e+01    3.859e+01    4.389e+01
-1.30e+00    2.662e+01    2.651e+01    2.662e+01
-1.10e+00    9.358e+00    1.444e+01    9.359e+00
-9.00e-01    3.399e-02    2.517e+00    3.554e-02
-7.00e-01    3.426e-04    1.577e-02    9.211e-04
-5.00e-01    2.840e-06    7.857e-05    1.655e-05
-3.00e-01    3.401e-09    6.836e-07    1.946e-08
-1.00e-01    6.162e-11    7.379e-09    7.622e-11
0.000e+00    5.758e-11    2.438e-09    6.240e-11
|
[Ramp]
R_load = 50.00
|voltage      I (typ)      I (min)      I (max)
|
|
dV/dt_r      1.680/0.164  1.360/0.329  1.900/0.124
|
|
dV/dt_f      1.690/0.219  1.310/0.442  1.880/0.155
|
|
[Model]      icbc_o
Model_type   3-state
Polarity     Non-Inverting
C_comp       5.00pF      5.00pF      5.00pF
|
|
[Voltage Range]  3.3v      3v      3.6v
[Pulldown]
|voltage      I (typ)      I (min)      I (max)
|
-3.30e+00    -5.20e+02    -3.65e+02    -5.18e+02
-3.10e+00    -4.69e+02    -3.30e+02    -4.67e+02
-2.90e+00    -4.18e+02    -2.94e+02    -4.16e+02
-2.70e+00    -3.67e+02    -2.59e+02    -3.65e+02
-2.50e+00    -3.16e+02    -2.23e+02    -3.14e+02
-2.30e+00    -2.65e+02    -1.88e+02    -2.63e+02
-2.10e+00    -2.14e+02    -1.52e+02    -2.11e+02
-1.90e+00    -1.63e+02    -1.17e+02    -1.60e+02
-1.70e+00    -1.13e+02    -9.25e+01    -1.10e+02
-1.50e+00    -7.83e+01    -6.88e+01    -7.58e+01
-1.30e+00    -4.42e+01    -4.51e+01    -4.17e+01
-1.10e+00    -1.02e+01    -2.15e+01    -7.67e+00
-9.00e-01    -2.51e-02    -1.18e+00    -2.65e-02
-7.00e-01    -1.30e-02    -1.16e-02    -1.58e-02
-5.00e-01    -9.33e-03    -4.67e-03    -1.10e-02
-3.00e-01    -5.75e-03    -2.81e-03    -6.76e-03
-1.00e-01    -1.97e-03    -9.48e-04    -2.32e-03
1.000e-01    1.945e-03    9.285e-04    2.307e-03
3.000e-01    5.507e-03    2.640e-03    6.599e-03
5.000e-01    8.649e-03    4.168e-03    1.048e-02
7.000e-01    1.136e-02    5.504e-03    1.393e-02
9.000e-01    1.364e-02    6.636e-03    1.693e-02
1.100e+00    1.547e-02    7.551e-03    1.950e-02

```

| | | | |
|-----------|-----------|-----------|-----------|
| 1.300e+00 | 1.688e-02 | 8.240e-03 | 2.162e-02 |
| 1.500e+00 | 9.632e-02 | 4.783e-02 | 2.331e-02 |
| 1.700e+00 | 1.012e-01 | 4.994e-02 | 1.302e-01 |
| 1.900e+00 | 1.039e-01 | 5.118e-02 | 1.369e-01 |
| 2.100e+00 | 1.053e-01 | 5.184e-02 | 1.412e-01 |
| 2.300e+00 | 1.060e-01 | 5.223e-02 | 1.436e-01 |
| 2.500e+00 | 1.065e-01 | 5.251e-02 | 1.449e-01 |
| 2.700e+00 | 1.069e-01 | 5.274e-02 | 1.458e-01 |
| 2.900e+00 | 1.073e-01 | 5.293e-02 | 1.464e-01 |
| 3.100e+00 | 1.076e-01 | 5.309e-02 | 1.470e-01 |
| 3.300e+00 | 1.078e-01 | 5.324e-02 | 1.475e-01 |
| 3.500e+00 | 1.081e-01 | 5.344e-02 | 1.479e-01 |
| 3.700e+00 | 1.083e-01 | 6.705e-02 | 1.483e-01 |
| 3.900e+00 | 1.086e-01 | 2.529e+00 | 1.487e-01 |
| 4.100e+00 | 1.103e-01 | 1.438e+01 | 1.491e-01 |
| 4.300e+00 | 1.437e+00 | 2.638e+01 | 1.503e-01 |
| 4.500e+00 | 1.800e+01 | 3.839e+01 | 1.810e-01 |
| 4.700e+00 | 3.519e+01 | 5.041e+01 | 9.452e+00 |
| 4.900e+00 | 5.241e+01 | 6.419e+01 | 2.664e+01 |
| 5.100e+00 | 7.505e+01 | 8.210e+01 | 4.384e+01 |
| 5.300e+00 | 1.007e+02 | 1.000e+02 | 6.224e+01 |
| 5.500e+00 | 1.264e+02 | 1.179e+02 | 8.794e+01 |
| 5.700e+00 | 1.522e+02 | 1.359e+02 | 1.136e+02 |
| 5.900e+00 | 1.779e+02 | 1.538e+02 | 1.394e+02 |
| 6.100e+00 | 2.036e+02 | 1.717e+02 | 1.651e+02 |
| 6.300e+00 | 2.293e+02 | 1.896e+02 | 1.908e+02 |
| 6.500e+00 | 2.550e+02 | 2.075e+02 | 2.165e+02 |
| 6.600e+00 | 2.678e+02 | 2.165e+02 | 2.293e+02 |
| | | | |
| [Pullup] | | | |
| voltage | I (typ) | I (min) | I (max) |
| | | | |
| -3.30e+00 | 2.677e+02 | 1.896e+02 | 2.677e+02 |
| -3.10e+00 | 2.420e+02 | 1.716e+02 | 2.420e+02 |
| -2.90e+00 | 2.163e+02 | 1.537e+02 | 2.163e+02 |
| -2.70e+00 | 1.906e+02 | 1.358e+02 | 1.906e+02 |
| -2.50e+00 | 1.649e+02 | 1.179e+02 | 1.649e+02 |
| -2.30e+00 | 1.392e+02 | 9.996e+01 | 1.392e+02 |
| -2.10e+00 | 1.135e+02 | 8.205e+01 | 1.135e+02 |
| -1.90e+00 | 8.778e+01 | 6.413e+01 | 8.778e+01 |
| -1.70e+00 | 6.208e+01 | 5.035e+01 | 6.208e+01 |
| -1.50e+00 | 4.368e+01 | 3.834e+01 | 4.368e+01 |
| -1.30e+00 | 2.649e+01 | 2.633e+01 | 2.649e+01 |
| -1.10e+00 | 9.302e+00 | 1.433e+01 | 9.303e+00 |
| -9.00e-01 | 3.838e-02 | 2.477e+00 | 4.183e-02 |
| -7.00e-01 | 8.115e-03 | 1.789e-02 | 1.045e-02 |
| -5.00e-01 | 5.634e-03 | 3.503e-03 | 7.064e-03 |
| -3.00e-01 | 3.370e-03 | 2.053e-03 | 4.233e-03 |
| -1.00e-01 | 1.118e-03 | 6.789e-04 | 1.410e-03 |
| 1.000e-01 | -1.09e-03 | -6.56e-04 | -1.38e-03 |
| 3.000e-01 | -3.12e-03 | -1.86e-03 | -3.99e-03 |
| 5.000e-01 | -4.96e-03 | -2.93e-03 | -6.39e-03 |
| 7.000e-01 | -6.60e-03 | -3.87e-03 | -8.59e-03 |
| 9.000e-01 | -8.04e-03 | -4.66e-03 | -1.06e-02 |
| 1.100e+00 | -9.26e-03 | -5.30e-03 | -1.23e-02 |

| | | | |
|---------------|-----------|-----------|-----------|
| 1.300e+00 | -1.03e-02 | -4.75e-02 | -1.41e-02 |
| 1.500e+00 | -9.03e-02 | -5.02e-02 | -1.23e-01 |
| 1.700e+00 | -9.49e-02 | -5.21e-02 | -1.31e-01 |
| 1.900e+00 | -9.84e-02 | -5.34e-02 | -1.38e-01 |
| 2.100e+00 | -1.01e-01 | -5.45e-02 | -1.43e-01 |
| 2.300e+00 | -1.03e-01 | -5.54e-02 | -1.47e-01 |
| 2.500e+00 | -1.05e-01 | -5.62e-02 | -1.50e-01 |
| 2.700e+00 | -1.06e-01 | -5.68e-02 | -1.52e-01 |
| 2.900e+00 | -1.07e-01 | -5.74e-02 | -1.54e-01 |
| 3.100e+00 | -1.08e-01 | -5.79e-02 | -1.56e-01 |
| 3.300e+00 | -1.09e-01 | -5.84e-02 | -1.57e-01 |
| 3.500e+00 | -1.10e-01 | -5.89e-02 | -1.59e-01 |
| 3.700e+00 | -1.11e-01 | -6.49e-02 | -1.60e-01 |
| 3.900e+00 | -1.11e-01 | -1.23e+00 | -1.61e-01 |
| 4.100e+00 | -1.14e-01 | -2.16e+01 | -1.62e-01 |
| 4.300e+00 | -4.76e-01 | -4.52e+01 | -1.64e-01 |
| 4.500e+00 | -2.73e+01 | -6.89e+01 | -1.73e-01 |
| 4.700e+00 | -6.14e+01 | -9.25e+01 | -7.82e+00 |
| 4.900e+00 | -9.54e+01 | -1.17e+02 | -4.19e+01 |
| 5.100e+00 | -1.38e+02 | -1.52e+02 | -7.59e+01 |
| 5.300e+00 | -1.89e+02 | -1.88e+02 | -1.11e+02 |
| 5.500e+00 | -2.40e+02 | -2.23e+02 | -1.61e+02 |
| 5.700e+00 | -2.91e+02 | -2.59e+02 | -2.12e+02 |
| 5.900e+00 | -3.42e+02 | -2.94e+02 | -2.63e+02 |
| 6.100e+00 | -3.93e+02 | -3.30e+02 | -3.14e+02 |
| 6.300e+00 | -4.44e+02 | -3.65e+02 | -3.65e+02 |
| 6.500e+00 | -4.95e+02 | -4.01e+02 | -4.16e+02 |
| 6.600e+00 | -5.20e+02 | -4.18e+02 | -4.41e+02 |
| | | | |
| [GND_clamp] | | | |
| voltage | I (typ) | I (min) | I (max) |
| | | | |
| -3.30e+00 | -5.20e+02 | -3.65e+02 | -5.18e+02 |
| -3.10e+00 | -4.69e+02 | -3.30e+02 | -4.67e+02 |
| -2.90e+00 | -4.18e+02 | -2.94e+02 | -4.16e+02 |
| -2.70e+00 | -3.67e+02 | -2.59e+02 | -3.65e+02 |
| -2.50e+00 | -3.16e+02 | -2.23e+02 | -3.14e+02 |
| -2.30e+00 | -2.65e+02 | -1.88e+02 | -2.63e+02 |
| -2.10e+00 | -2.14e+02 | -1.52e+02 | -2.11e+02 |
| -1.90e+00 | -1.63e+02 | -1.17e+02 | -1.60e+02 |
| -1.70e+00 | -1.13e+02 | -9.25e+01 | -1.10e+02 |
| -1.50e+00 | -7.83e+01 | -6.88e+01 | -7.58e+01 |
| -1.30e+00 | -4.42e+01 | -4.51e+01 | -4.17e+01 |
| -1.10e+00 | -1.02e+01 | -2.15e+01 | -7.66e+00 |
| -9.00e-01 | -1.03e-02 | -1.17e+00 | -9.27e-03 |
| -7.00e-01 | -3.74e-04 | -5.73e-03 | -1.14e-03 |
| -5.00e-01 | -1.72e-06 | -5.06e-05 | -1.28e-05 |
| -3.00e-01 | -1.67e-09 | -4.65e-07 | -1.10e-08 |
| -1.00e-01 | -2.03e-11 | -4.80e-09 | -2.71e-11 |
| 0.000e+00 | -1.69e-11 | -1.61e-09 | -1.89e-11 |
| | | | |
| [POWER_clamp] | | | |
| voltage | I (typ) | I (min) | I (max) |
| | | | |
| -3.30e+00 | 2.677e+02 | 1.896e+02 | 2.677e+02 |

```

-3.10e+00    2.420e+02    1.716e+02    2.420e+02
-2.90e+00    2.163e+02    1.537e+02    2.163e+02
-2.70e+00    1.906e+02    1.358e+02    1.906e+02
-2.50e+00    1.649e+02    1.179e+02    1.649e+02
-2.30e+00    1.392e+02    9.996e+01    1.392e+02
-2.10e+00    1.135e+02    8.205e+01    1.135e+02
-1.90e+00    8.778e+01    6.413e+01    8.778e+01
-1.70e+00    6.208e+01    5.035e+01    6.208e+01
-1.50e+00    4.368e+01    3.834e+01    4.368e+01
-1.30e+00    2.649e+01    2.633e+01    2.649e+01
-1.10e+00    9.300e+00    1.433e+01    9.301e+00
-9.00e-01    2.962e-02    2.475e+00    3.075e-02
-7.00e-01    2.501e-04    1.354e-02    6.708e-04
-5.00e-01    2.066e-06    6.280e-05    1.204e-05
-3.00e-01    2.487e-09    5.128e-07    1.417e-08
-1.00e-01    5.672e-11    5.639e-09    6.832e-11
0.000e+00    5.334e-11    1.992e-09    5.783e-11
|
[Ramp]
R_load = 50.00
|voltage      I (typ)          I (min)          I (max)
|
|
dV/dt_r      1.570/0.200    1.210/0.411    1.810/0.149
|
|
dV/dt_f      1.590/0.304    1.170/0.673    1.800/0.205
|
|
[Model]      ipbw_i
Model_type   Input
Polarity     Non-Inverting
Vinl= 0.8000v
Vinh= 2.000v
C_comp      5.00pF          5.00pF          5.00pF
|
|
[Voltage Range]  3.3v          3v          3.6v
[GND_clamp]
|voltage      I (typ)          I (min)          I (max)
|
-3.30e+00    -5.20e+02    -3.65e+02    -5.17e+02
-3.10e+00    -4.69e+02    -3.29e+02    -4.66e+02
-2.90e+00    -4.18e+02    -2.94e+02    -4.15e+02
-2.70e+00    -3.67e+02    -2.58e+02    -3.64e+02
-2.50e+00    -3.16e+02    -2.23e+02    -3.13e+02
-2.30e+00    -2.65e+02    -1.88e+02    -2.62e+02
-2.10e+00    -2.14e+02    -1.52e+02    -2.11e+02
-1.90e+00    -1.63e+02    -1.17e+02    -1.60e+02
-1.70e+00    -1.13e+02    -9.24e+01    -1.10e+02
-1.50e+00    -7.82e+01    -6.87e+01    -7.57e+01
-1.30e+00    -4.42e+01    -4.51e+01    -4.16e+01
-1.10e+00    -1.02e+01    -2.15e+01    -7.64e+00
-9.00e-01    -7.17e-03    -1.16e+00    -4.87e-03
-7.00e-01    -1.14e-04    -4.39e-03    -3.03e-04

```

```

-5.00e-01  -4.86e-07  -2.55e-05  -2.73e-06
-3.00e-01  -5.19e-10  -1.91e-07  -2.57e-09
-1.00e-01  -1.91e-11  -2.47e-09  -2.19e-11
0.000e+00  -1.68e-11  -1.17e-09  -1.84e-11
|
[POWER_clamp]
|voltage          I (typ)          I (min)          I (max)
|
-3.30e+00  2.667e+02  1.885e+02  2.667e+02
-3.10e+00  2.411e+02  1.707e+02  2.411e+02
-2.90e+00  2.155e+02  1.528e+02  2.155e+02
-2.70e+00  1.898e+02  1.350e+02  1.898e+02
-2.50e+00  1.642e+02  1.172e+02  1.642e+02
-2.30e+00  1.386e+02  9.935e+01  1.386e+02
-2.10e+00  1.130e+02  8.152e+01  1.130e+02
-1.90e+00  8.739e+01  6.369e+01  8.739e+01
-1.70e+00  6.178e+01  4.999e+01  6.178e+01
-1.50e+00  4.346e+01  3.806e+01  4.346e+01
-1.30e+00  2.634e+01  2.613e+01  2.634e+01
-1.10e+00  9.237e+00  1.421e+01  9.237e+00
-9.00e-01  2.454e-02  2.430e+00  2.488e-02
-7.00e-01  8.741e-05  1.104e-02  2.050e-04
-5.00e-01  6.316e-07  4.079e-05  2.961e-06
-3.00e-01  8.479e-10  2.484e-07  3.721e-09
-1.00e-01  4.420e-11  3.001e-09  4.943e-11
0.000e+00  4.215e-11  1.346e-09  4.543e-11
|
|
[Model]          ipbw_io
Model_type       I/O
Polarity         Non-Inverting
Vinl= 0.8000v
Vinh= 2.000v
C_comp          5.00pF          5.00pF          5.00pF
|
|
[Voltage Range]  3.3v          3v          3.6v
[Pulldown]
|voltage          I (typ)          I (min)          I (max)
|
-3.30e+00  -5.20e+02  -3.65e+02  -5.17e+02
-3.10e+00  -4.69e+02  -3.29e+02  -4.66e+02
-2.90e+00  -4.18e+02  -2.94e+02  -4.15e+02
-2.70e+00  -3.67e+02  -2.58e+02  -3.64e+02
-2.50e+00  -3.16e+02  -2.23e+02  -3.13e+02
-2.30e+00  -2.65e+02  -1.88e+02  -2.62e+02
-2.10e+00  -2.14e+02  -1.52e+02  -2.11e+02
-1.90e+00  -1.63e+02  -1.17e+02  -1.60e+02
-1.70e+00  -1.13e+02  -9.24e+01  -1.10e+02
-1.50e+00  -7.82e+01  -6.87e+01  -7.57e+01
-1.30e+00  -4.42e+01  -4.51e+01  -4.17e+01
-1.10e+00  -1.02e+01  -2.15e+01  -7.66e+00
-9.00e-01  -3.69e-02  -1.17e+00  -3.79e-02
-7.00e-01  -2.52e-02  -1.67e-02  -2.81e-02
-5.00e-01  -1.83e-02  -9.77e-03  -2.04e-02

```

| | | | |
|-----------|-----------|-----------|-----------|
| -3.00e-01 | -1.11e-02 | -5.89e-03 | -1.24e-02 |
| -1.00e-01 | -3.77e-03 | -1.98e-03 | -4.20e-03 |
| 1.000e-01 | 3.729e-03 | 1.940e-03 | 4.177e-03 |
| 3.000e-01 | 1.076e-02 | 5.578e-03 | 1.216e-02 |
| 5.000e-01 | 1.723e-02 | 8.907e-03 | 1.965e-02 |
| 7.000e-01 | 2.311e-02 | 1.191e-02 | 2.663e-02 |
| 9.000e-01 | 2.836e-02 | 1.455e-02 | 3.305e-02 |
| 1.100e+00 | 3.292e-02 | 1.680e-02 | 3.887e-02 |
| 1.300e+00 | 3.675e-02 | 1.862e-02 | 4.404e-02 |
| 1.500e+00 | 3.979e-02 | 1.997e-02 | 4.850e-02 |
| 1.700e+00 | 4.205e-02 | 2.085e-02 | 5.223e-02 |
| 1.900e+00 | 4.347e-02 | 2.136e-02 | 5.518e-02 |
| 2.100e+00 | 4.413e-02 | 2.162e-02 | 5.728e-02 |
| 2.300e+00 | 4.445e-02 | 2.176e-02 | 5.843e-02 |
| 2.500e+00 | 4.465e-02 | 2.186e-02 | 5.899e-02 |
| 2.700e+00 | 4.479e-02 | 2.194e-02 | 5.931e-02 |
| 2.900e+00 | 4.492e-02 | 2.200e-02 | 5.953e-02 |
| 3.100e+00 | 4.502e-02 | 2.206e-02 | 5.971e-02 |
| 3.300e+00 | 4.511e-02 | 2.211e-02 | 5.986e-02 |
| 3.500e+00 | 4.519e-02 | 2.219e-02 | 5.999e-02 |
| 3.700e+00 | 4.526e-02 | 3.324e-02 | 6.010e-02 |
| 3.900e+00 | 4.536e-02 | 2.452e+00 | 6.021e-02 |
| 4.100e+00 | 4.614e-02 | 1.423e+01 | 6.032e-02 |
| 4.300e+00 | 1.344e+00 | 2.615e+01 | 6.065e-02 |
| 4.500e+00 | 1.783e+01 | 3.808e+01 | 8.548e-02 |
| 4.700e+00 | 3.495e+01 | 5.001e+01 | 9.298e+00 |
| 4.900e+00 | 5.208e+01 | 6.371e+01 | 2.640e+01 |
| 5.100e+00 | 7.463e+01 | 8.154e+01 | 4.352e+01 |
| 5.300e+00 | 1.002e+02 | 9.937e+01 | 6.184e+01 |
| 5.500e+00 | 1.259e+02 | 1.172e+02 | 8.745e+01 |
| 5.700e+00 | 1.515e+02 | 1.350e+02 | 1.131e+02 |
| 5.900e+00 | 1.771e+02 | 1.529e+02 | 1.387e+02 |
| 6.100e+00 | 2.027e+02 | 1.707e+02 | 1.643e+02 |
| 6.300e+00 | 2.283e+02 | 1.885e+02 | 1.899e+02 |
| 6.500e+00 | 2.539e+02 | 2.064e+02 | 2.155e+02 |
| 6.600e+00 | 2.667e+02 | 2.153e+02 | 2.283e+02 |
| | | | |
| [Pullup] | | | |
| voltage | I (typ) | I (min) | I (max) |
| | | | |
| -3.30e+00 | 2.667e+02 | 1.885e+02 | 2.667e+02 |
| -3.10e+00 | 2.411e+02 | 1.707e+02 | 2.411e+02 |
| -2.90e+00 | 2.155e+02 | 1.528e+02 | 2.155e+02 |
| -2.70e+00 | 1.898e+02 | 1.350e+02 | 1.898e+02 |
| -2.50e+00 | 1.642e+02 | 1.172e+02 | 1.642e+02 |
| -2.30e+00 | 1.386e+02 | 9.935e+01 | 1.386e+02 |
| -2.10e+00 | 1.130e+02 | 8.152e+01 | 1.130e+02 |
| -1.90e+00 | 8.739e+01 | 6.369e+01 | 8.739e+01 |
| -1.70e+00 | 6.178e+01 | 4.999e+01 | 6.178e+01 |
| -1.50e+00 | 4.346e+01 | 3.806e+01 | 4.346e+01 |
| -1.30e+00 | 2.635e+01 | 2.613e+01 | 2.635e+01 |
| -1.10e+00 | 9.243e+00 | 1.421e+01 | 9.245e+00 |
| -9.00e-01 | 5.536e-02 | 2.435e+00 | 6.260e-02 |
| -7.00e-01 | 2.847e-02 | 2.689e-02 | 3.437e-02 |
| -5.00e-01 | 2.025e-02 | 1.265e-02 | 2.451e-02 |

| | | | |
|-------------|-----------|-----------|-----------|
| -3.00e-01 | 1.208e-02 | 7.503e-03 | 1.467e-02 |
| -1.00e-01 | 3.994e-03 | 2.474e-03 | 4.868e-03 |
| 1.000e-01 | -3.88e-03 | -2.38e-03 | -4.76e-03 |
| 3.000e-01 | -1.11e-02 | -6.76e-03 | -1.37e-02 |
| 5.000e-01 | -1.76e-02 | -1.06e-02 | -2.20e-02 |
| 7.000e-01 | -2.35e-02 | -1.40e-02 | -2.95e-02 |
| 9.000e-01 | -2.86e-02 | -1.69e-02 | -3.63e-02 |
| 1.100e+00 | -3.30e-02 | -1.93e-02 | -4.23e-02 |
| 1.300e+00 | -3.65e-02 | -2.10e-02 | -4.75e-02 |
| 1.500e+00 | -3.92e-02 | -2.22e-02 | -5.17e-02 |
| 1.700e+00 | -4.12e-02 | -2.29e-02 | -5.51e-02 |
| 1.900e+00 | -4.26e-02 | -2.35e-02 | -5.77e-02 |
| 2.100e+00 | -4.36e-02 | -2.38e-02 | -5.97e-02 |
| 2.300e+00 | -4.43e-02 | -2.42e-02 | -6.11e-02 |
| 2.500e+00 | -4.49e-02 | -2.44e-02 | -6.22e-02 |
| 2.700e+00 | -4.54e-02 | -2.47e-02 | -6.31e-02 |
| 2.900e+00 | -4.58e-02 | -2.49e-02 | -6.38e-02 |
| 3.100e+00 | -4.61e-02 | -2.50e-02 | -6.44e-02 |
| 3.300e+00 | -4.65e-02 | -2.52e-02 | -6.49e-02 |
| 3.500e+00 | -4.68e-02 | -2.54e-02 | -6.54e-02 |
| 3.700e+00 | -4.70e-02 | -2.99e-02 | -6.58e-02 |
| 3.900e+00 | -4.73e-02 | -1.19e+00 | -6.62e-02 |
| 4.100e+00 | -4.81e-02 | -2.15e+01 | -6.66e-02 |
| 4.300e+00 | -4.00e-01 | -4.51e+01 | -6.72e-02 |
| 4.500e+00 | -2.72e+01 | -6.87e+01 | -7.21e-02 |
| 4.700e+00 | -6.12e+01 | -9.24e+01 | -7.70e+00 |
| 4.900e+00 | -9.52e+01 | -1.17e+02 | -4.17e+01 |
| 5.100e+00 | -1.37e+02 | -1.52e+02 | -7.57e+01 |
| 5.300e+00 | -1.88e+02 | -1.88e+02 | -1.10e+02 |
| 5.500e+00 | -2.39e+02 | -2.23e+02 | -1.60e+02 |
| 5.700e+00 | -2.90e+02 | -2.58e+02 | -2.11e+02 |
| 5.900e+00 | -3.41e+02 | -2.94e+02 | -2.62e+02 |
| 6.100e+00 | -3.92e+02 | -3.29e+02 | -3.13e+02 |
| 6.300e+00 | -4.43e+02 | -3.65e+02 | -3.64e+02 |
| 6.500e+00 | -4.94e+02 | -4.00e+02 | -4.15e+02 |
| 6.600e+00 | -5.20e+02 | -4.18e+02 | -4.41e+02 |
| | | | |
| [GND_clamp] | | | |
| voltage | I (typ) | I (min) | I (max) |
| | | | |
| -3.30e+00 | -5.20e+02 | -3.65e+02 | -5.17e+02 |
| -3.10e+00 | -4.69e+02 | -3.29e+02 | -4.66e+02 |
| -2.90e+00 | -4.18e+02 | -2.94e+02 | -4.15e+02 |
| -2.70e+00 | -3.67e+02 | -2.58e+02 | -3.64e+02 |
| -2.50e+00 | -3.16e+02 | -2.23e+02 | -3.13e+02 |
| -2.30e+00 | -2.65e+02 | -1.88e+02 | -2.62e+02 |
| -2.10e+00 | -2.14e+02 | -1.52e+02 | -2.11e+02 |
| -1.90e+00 | -1.63e+02 | -1.17e+02 | -1.60e+02 |
| -1.70e+00 | -1.13e+02 | -9.24e+01 | -1.10e+02 |
| -1.50e+00 | -7.82e+01 | -6.87e+01 | -7.57e+01 |
| -1.30e+00 | -4.42e+01 | -4.51e+01 | -4.16e+01 |
| -1.10e+00 | -1.02e+01 | -2.15e+01 | -7.64e+00 |
| -9.00e-01 | -7.17e-03 | -1.16e+00 | -4.87e-03 |
| -7.00e-01 | -1.14e-04 | -4.39e-03 | -3.03e-04 |
| -5.00e-01 | -4.86e-07 | -2.55e-05 | -2.73e-06 |

```

-3.00e-01  -5.19e-10  -1.91e-07  -2.57e-09
-1.00e-01  -1.91e-11  -2.47e-09  -2.19e-11
0.000e+00  -1.68e-11  -1.17e-09  -1.84e-11
|
[POWER_clamp]
|voltage          I (typ)          I (min)          I (max)
|
-3.30e+00  2.667e+02  1.885e+02  2.667e+02
-3.10e+00  2.411e+02  1.707e+02  2.411e+02
-2.90e+00  2.155e+02  1.528e+02  2.155e+02
-2.70e+00  1.898e+02  1.350e+02  1.898e+02
-2.50e+00  1.642e+02  1.172e+02  1.642e+02
-2.30e+00  1.386e+02  9.935e+01  1.386e+02
-2.10e+00  1.130e+02  8.152e+01  1.130e+02
-1.90e+00  8.739e+01  6.369e+01  8.739e+01
-1.70e+00  6.178e+01  4.999e+01  6.178e+01
-1.50e+00  4.346e+01  3.806e+01  4.346e+01
-1.30e+00  2.634e+01  2.613e+01  2.634e+01
-1.10e+00  9.237e+00  1.421e+01  9.237e+00
-9.00e-01  2.454e-02  2.430e+00  2.488e-02
-7.00e-01  8.741e-05  1.104e-02  2.050e-04
-5.00e-01  6.316e-07  4.079e-05  2.961e-06
-3.00e-01  8.479e-10  2.484e-07  3.721e-09
-1.00e-01  4.420e-11  3.001e-09  4.943e-11
0.000e+00  4.215e-11  1.346e-09  4.543e-11
|
[Ramp]
R_load = 50.00
|voltage          I (typ)          I (min)          I (max)
|
|
dV/dt_r          1.140/0.494    0.699/0.978    1.400/0.354
|
|
dV/dt_f          1.150/0.505    0.642/0.956    1.350/0.350
|
|
[Model]          iexlh_i
Model_type       Input
Polarity         Non-Inverting
Vinl= 0.8000v
Vinh= 2.000v
C_comp          5.00pF          5.00pF          5.00pF
|
|
[Voltage Range]  3.3v           3v              3.6v
[GND_clamp]
|voltage          I (typ)          I (min)          I (max)
|
-3.30e+00  -5.21e+02  -3.66e+02  -5.18e+02
-3.10e+00  -4.70e+02  -3.30e+02  -4.67e+02
-2.90e+00  -4.19e+02  -2.95e+02  -4.16e+02
-2.70e+00  -3.68e+02  -2.59e+02  -3.65e+02
-2.50e+00  -3.17e+02  -2.24e+02  -3.14e+02
-2.30e+00  -2.66e+02  -1.89e+02  -2.63e+02

```

```

-2.10e+00  -2.15e+02  -1.53e+02  -2.12e+02
-1.90e+00  -1.64e+02  -1.18e+02  -1.61e+02
-1.70e+00  -1.14e+02  -9.34e+01  -1.11e+02
-1.50e+00  -7.93e+01  -6.98e+01  -7.68e+01
-1.30e+00  -4.53e+01  -4.62e+01  -4.28e+01
-1.10e+00  -1.13e+01  -2.26e+01  -8.78e+00
-9.00e-01  -7.94e-03  -1.87e+00  -3.77e-03
-7.00e-01  -1.62e-06  -5.11e-03  -7.69e-07
-5.00e-01  -3.45e-10  -1.40e-05  -1.72e-10
-3.00e-01  -1.29e-11  -3.90e-08  -1.38e-11
-1.00e-01  -1.10e-11  -8.67e-10  -1.19e-11
0.000e+00  -1.01e-11  -7.13e-10  -1.10e-11
|
[POWER_clamp]
|voltage          I (typ)          I (min)          I (max)
|
-3.30e+00  2.653e+02  1.870e+02  2.653e+02
-3.10e+00  2.398e+02  1.693e+02  2.398e+02
-2.90e+00  2.143e+02  1.516e+02  2.143e+02
-2.70e+00  1.888e+02  1.339e+02  1.888e+02
-2.50e+00  1.633e+02  1.162e+02  1.633e+02
-2.30e+00  1.378e+02  9.847e+01  1.378e+02
-2.10e+00  1.123e+02  8.076e+01  1.123e+02
-1.90e+00  8.682e+01  6.305e+01  8.682e+01
-1.70e+00  6.133e+01  4.947e+01  6.133e+01
-1.50e+00  4.313e+01  3.766e+01  4.313e+01
-1.30e+00  2.614e+01  2.585e+01  2.614e+01
-1.10e+00  9.145e+00  1.404e+01  9.145e+00
-9.00e-01  1.797e-02  2.364e+00  1.797e-02
-7.00e-01  3.667e-06  7.589e-03  3.667e-06
-5.00e-01  7.730e-10  2.072e-05  7.748e-10
-3.00e-01  2.293e-11  5.767e-08  2.476e-11
-1.00e-01  2.096e-11  1.163e-09  2.278e-11
0.000e+00  2.004e-11  9.618e-10  2.186e-11
|
[End]

```

Index

A

- ac electrical characteristics 3
- Address Trace mode 3, 38, 41
- applications 5
- arbitration bus timings 41

B

- bootstrap ROM 3
- Boundary Scan (JTAG Port) timing diagram 72
- bus
 - address 2
 - data 2
 - multiplexed 2
 - non-multiplexed 2
- bus acquisition timings 42
- bus release timings 43, 44

C

- clock
 - external 4
 - operation 5
- clocks
 - internal 4

D

- data memory expansion 4
- DAX 4, 2, 16
- dc electrical characteristics 2
- Debug support 3
- design considerations

- electrical 3
- PLL 4, 5
- power consumption 3
- thermal 1

- Digital Audio Transmitter 4, 16

- DRAM

- out of page
 - read access 36
 - wait states selection guide 28
 - write access 37
- out of page and refresh timings
 - 11 wait states 32
 - 15 wait states 33
 - 4 wait states 28
 - 8 wait states 30

- Page mode

- read accesses 27
- wait states selection guide 19
- write accesses 26

- Page mode timings

- 1 wait state 19
- 2 wait states 21
- 3 wait states 22
- 4 wait states 24

- refresh access 38

- DRAM controller 4

- DSP programming 6

E

- electrical design considerations 3
- Enhanced Serial Audio Interface 4
- ESAI 4, 2
- ESSI

- receiver timing 66, 67
- timings 62
- transmitter timing 65

- EXTAL jitter 5

- external bus control 6, 7

- external bus synchronous timings (SRAM access)

38
 external clock operation 4
 external interrupt timing (negative edge-triggered)
 11
 external level-sensitive fast interrupt timing 11
 external memory access (DMA Source) timing 13
 External Memory Expansion Port 14

F

functional groups 2
 functional signal groups 1

G

General Purpose Input/Output 4
 GPIO 4, 2, 19
 GPIO timing 69
 Ground 4
 PLL 4

H

HDI08 4, 2, 10, 12, 13
 DSP programming 6
 DSP synchronization 6
 Host synchronization 5
 HDI08 timing 46
 Host Interface 4, 2, 10, 12, 13
 Host Interface timing 46
 host port
 configuration 9
 Host Port considerations 5
 Host programming 5
 Host Request
 Double 2
 Single 2

I

instruction cache 3
 internal clocks 4
 interrupt and mode control 8
 interrupt control 8
 interrupt timing 7
 external level-sensitive fast 11
 external negative edge-triggered 11
 synchronous from Wait state 12

J

Jitter 5
 JTAG 20
 JTAG Port 3
 reset timing diagram 73
 timing 70, 72

M

maximum ratings 1
 Memory Expansion Port 3
 mode control 8
 Mode select timing 7
 multiplexed bus 2
 multiplexed bus timings
 read 50
 write 51

N

non-multiplexed bus 2
 non-multiplexed bus timings
 read 48
 write 49

O

- off-chip memory 3
- OnCE
 - module timing 73
- OnCE module 3, 20
 - Debug request 73
- on-chip DRAM controller 4
- On-Chip Emulation module 3
- on-chip memory 3
- operating mode select timing 12

P

- package
 - 144-pin TQFP 1
 - TQFP description 1, 3
- Phase Lock Loop 6
- PLL 6
 - Characteristics 6
 - performance issues 4
- PLL design considerations 4, 5
- PLL performance issues 5
- Port A 2
- Port B 2, 10, 11, 12, 13
- Port C 2, 16
- Port D 2, 16
- power consumption design considerations 3
- power management 5
- program memory expansion 4
- program RAM 3

R

- recovery from Stop state using IRQA 12, 13
- RESET 9
- Reset timing 7, 10
 - synchronous 10
- ROM, bootstrap 3

S

- Serial Host Interface 4, 14
- SHI 4, 2, 14
- signal groupings 1
- signals 1
 - functional grouping 2
- SRAM 40
 - Access 38
 - read access 17
 - read and write accesses 14
 - support 4
 - write access 17, 18
- Stop mode 5
- Stop state
 - recovery from 12, 13
- Stop timing 7
- supply voltage 1
- Switch mode 3
- Synchronization 5
- synchronous bus timings
 - SRAM
 - 2 wait states 41
 - SRAM 1 wait state (BCR controlled) 40
 - synchronous interrupt from Wait state timing 12
 - synchronous Reset timing 10

T

- TAP 3
- target applications 5
- Test Access Port 3
- Test Access Port timing diagram 72
- Test Clock (TCLK) input timing diagram 71
- thermal characteristics 2
- thermal design considerations 1
- Timer 4, 2, 19
 - event input restrictions 68
 - interrupt generation 68
 - timing 68
- Timing
 - Digital Audio Transmitter (DAX) 67

General Purpose I/O (GPIO) Timing 62
OnCE™ (On Chip Emulator) Timing 62
Serial Host Interface (SHI) SPI Protocol Tim-
ing 52
Serial Host Interface (SHI) Timing 52

timing

interrupt 7
mode select 7
Reset 7
Stop 7

TQFP 1

pin list by number 3
pin-out drawing (top) 1

W

Wait mode 5

X

X data RAM 3

Y

Y data RAM 3

How to Reach Us:

Home Page:
www.freescale.com

E-mail:
support@freescale.com

USA/Europe or Locations Not Listed:
Freescale Semiconductor
Technical Information Center, CH370
1300 N. Alma School Road
Chandler, Arizona 85224
+1-800-521-6274 or +1-480-768-2130
support@freescale.com

Europe, Middle East, and Africa:
Freescale Halbleiter Deutschland GmbH
Technical Information Center
Schatzbogen 7
81829 Muenchen, Germany
+44 1296 380 456 (English)
+46 8 52200080 (English)
+49 89 92103 559 (German)
+33 1 69 35 48 48 (French)
support@freescale.com

Japan:
Freescale Semiconductor Japan Ltd.
Headquarters
ARCO Tower 15F
1-8-1, Shimo-Meguro, Meguro-ku,
Tokyo 153-0064, Japan
0120 191014 or +81 3 5437 9125
support.japan@freescale.com

Asia/Pacific:
Freescale Semiconductor Hong Kong Ltd.
Technical Information Center
2 Dai King Street
Tai Po Industrial Estate
Tai Po, N.T., Hong Kong
+800 2666 8080
support.asia@freescale.com

For Literature Requests Only:
Freescale Semiconductor Literature Distribution Center
P.O. Box 5405
Denver, Colorado 80217
1-800-521-6274 or 303-675-2140

Information in this document is provided solely to enable system and software implementers to use Freescale Semiconductor products. There are no express or implied copyright licenses granted hereunder to design or fabricate any integrated circuits or integrated circuits based on the information in this document.

Freescale Semiconductor reserves the right to make changes without further notice to any products herein. Freescale Semiconductor makes no warranty, representation or guarantee regarding the suitability of its products for any particular purpose, nor does Freescale Semiconductor assume any liability arising out of the application or use of any product or circuit, and specifically disclaims any and all liability, including without limitation consequential or incidental damages. "Typical" parameters that may be provided in Freescale Semiconductor data sheets and/or specifications can and do vary in different applications and actual performance may vary over time. All operating parameters, including "Typicals", must be validated for each customer application by customer's technical experts. Freescale Semiconductor does not convey any license under its patent rights nor the rights of others. Freescale Semiconductor products are not designed, intended, or authorized for use as components in systems intended for surgical implant into the body, or other applications intended to support or sustain life, or for any other application in which the failure of the Freescale Semiconductor product could create a situation where personal injury or death may occur. Should Buyer purchase or use Freescale Semiconductor products for any such unintended or unauthorized application, Buyer shall indemnify and hold Freescale Semiconductor and its officers, employees, subsidiaries, affiliates, and distributors harmless against all claims, costs, damages, and expenses, and reasonable attorney fees arising out of, directly or indirectly, any claim of personal injury or death associated with such unintended or unauthorized use, even if such claim alleges that Freescale Semiconductor was negligent regarding the design or manufacture of the part.

Freescale™ and the Freescale logo are trademarks of Freescale Semiconductor, Inc. All other product or service names are the property of their respective owners.

© Freescale Semiconductor, Inc. 2006. All rights reserved.