



PCA8576D

Automotive 40 x 4 LCD segment driver for low multiplex rates up to 1:4

Rev. 2 — 6 June 2013

Product data sheet

1. General description

The PCA8576D is a peripheral device which interfaces to almost any Liquid Crystal Display (LCD) with low multiplex rates. It generates the drive signals for any static or multiplexed LCD containing up to four backplanes and up to 40 segments. It can be easily cascaded for larger LCD applications. The PCA8576D is compatible with most microcontrollers and communicates via the two-line bidirectional I²C-bus. Communication overheads are minimized by a display RAM with auto-incremented addressing, by hardware subaddressing and by display memory switching (static and duplex drive modes).

2. Features and benefits

- AEC-Q100 compliant for automotive applications
- Single chip LCD controller and driver
- Selectable backplane drive configuration: static or 2, 3, 4 backplane multiplexing
- Selectable display bias configuration: static, 1/2 or 1/3
- Internal LCD bias generation with voltage-follower buffers
- 40 segment drives:
 - ◆ Up to 20 7-segment numeric characters
 - ◆ Up to 10 14-segment alphanumeric characters
 - ◆ Any graphics of up to 160 elements
- 40 × 4-bit RAM for display data storage
- Auto-incremented display data loading across device subaddress boundaries
- Display memory bank switching in static and duplex drive modes
- Versatile blinking modes
- Independent supplies possible for LCD and logic voltages
- Wide power supply range: from 1.8 V to 5.5 V
- Wide logic LCD supply range:
 - ◆ From 2.5 V for low-threshold LCDs
 - ◆ Up to 6.5 V for high-threshold twisted nematic LCDs
- Low power consumption
- 400 kHz I²C-bus interface
- May be cascaded for large LCD applications (up to 2560 elements possible)
- No external components required
- Compatible with chip-on-glass and chip-on-board technology
- Manufactured in silicon gate CMOS process



3. Ordering information

Table 1. Ordering information

Type number	Package		
	Name	Description	Version
PCA8576DU	bare die	59 bumps	PCA8576DU/2DA

3.1 Ordering options

Table 2. Ordering options

Product type number	Sales item (12NC)	Orderable part number	IC revision	Delivery form
PCA8576DU/2DA/Q2	935294883026	PCA8576DU/2DA/Q2,0	1	chips with bumps in tray

4. Marking

Table 3. Marking codes

Product type number	Marking code
PCA8576DU/2DA/Q2	PC8576D-2

5. Block diagram

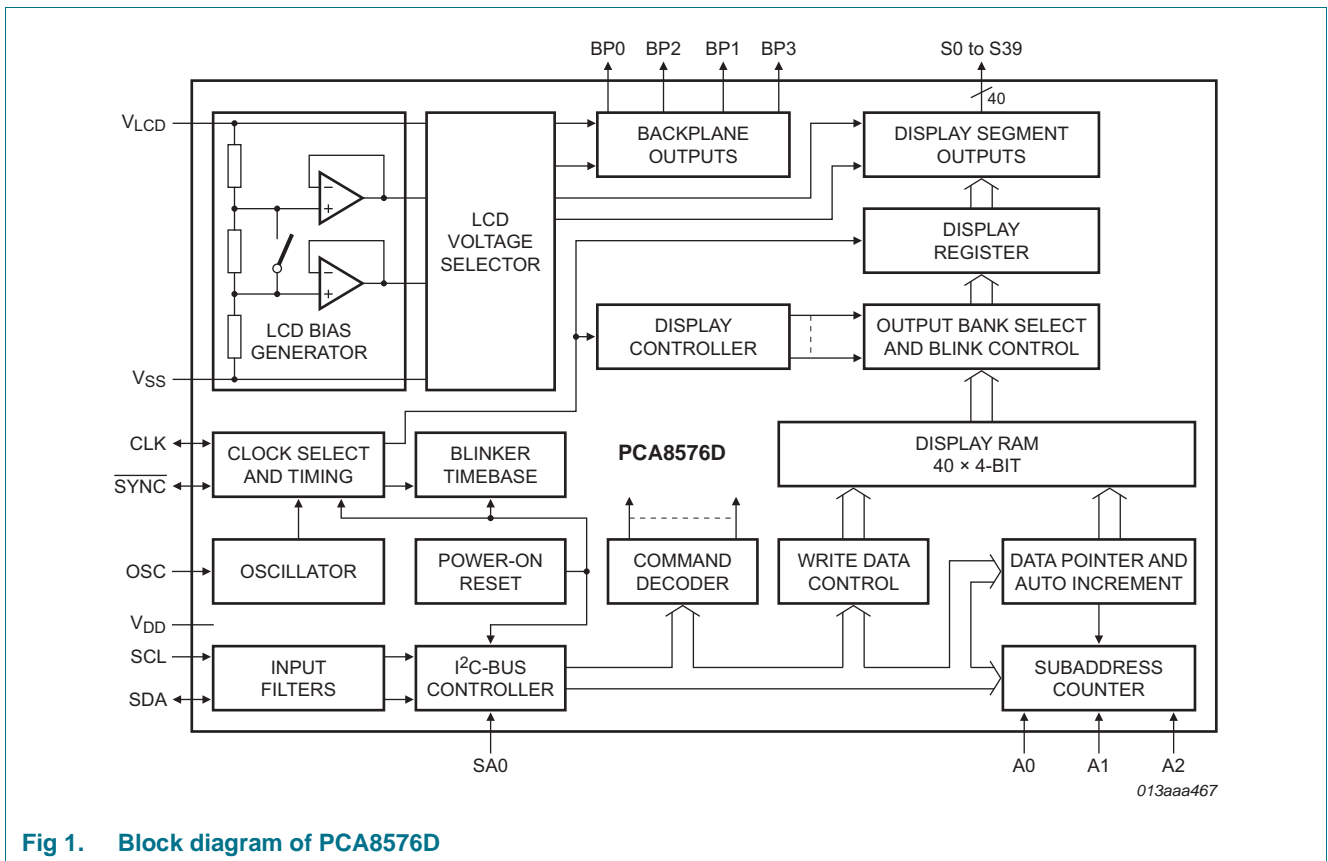
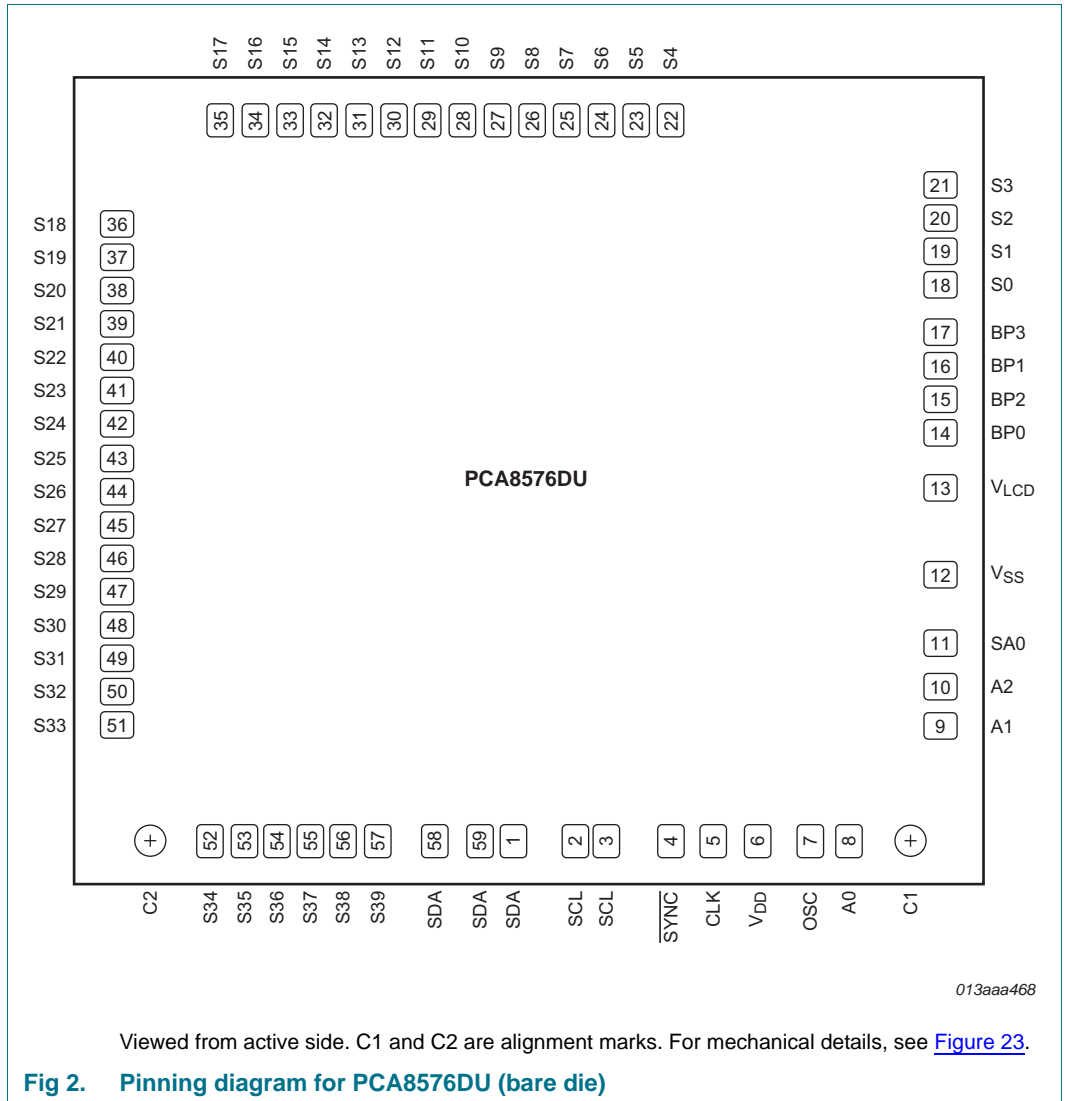

Fig 1. Block diagram of PCA8576D

6. Pinning information

6.1 Pinning



6.2 Pin description

Table 4. Pin description

Symbol	Pin PCA8576DU	Description
SDA	1, 58, 59	I ² C-bus serial data input and output
SCL	2, 3	I ² C-bus serial clock input
CLK	5	external clock input or output
V _{DD}	6	supply voltage
SYNC	4	cascade synchronization input or output
OSC	7	internal oscillator enable input
A0 to A2	8 to 10	subaddress inputs
SA0	11	I ² C-bus address input; bit 0
V _{SS}	12 ^[1]	ground supply voltage
V _{LCD}	13	LCD supply voltage
BP0, BP2, BP1, BP3	14 to 17	LCD backplane outputs
S0 to S39	18 to 57	LCD segment outputs

[1] The substrate (rear side of the die) is connected to V_{SS} and should be electrically isolated.

7. Functional description

The PCA8576D is a versatile peripheral device designed to interface any microcontroller with a wide variety of LCDs. It can directly drive any static or multiplexed LCD containing up to four backplanes and up to 40 segments.

The possible display configurations of the PCA8576D depend on the number of active backplane outputs required. A selection of display configurations is shown in [Table 5](#). All of these configurations can be implemented in the typical system shown in [Figure 3](#).

Table 5. Selection of possible display configurations

Number of Backplanes	Icons	Digits/Characters		Dot matrix/Elements
		7-segment	14-segment	
4	160	20	10	160 (4 × 40)
3	120	15	7	120 (3 × 40)
2	80	10	5	80 (2 × 40)
1	40	5	2	40 (1 × 40)

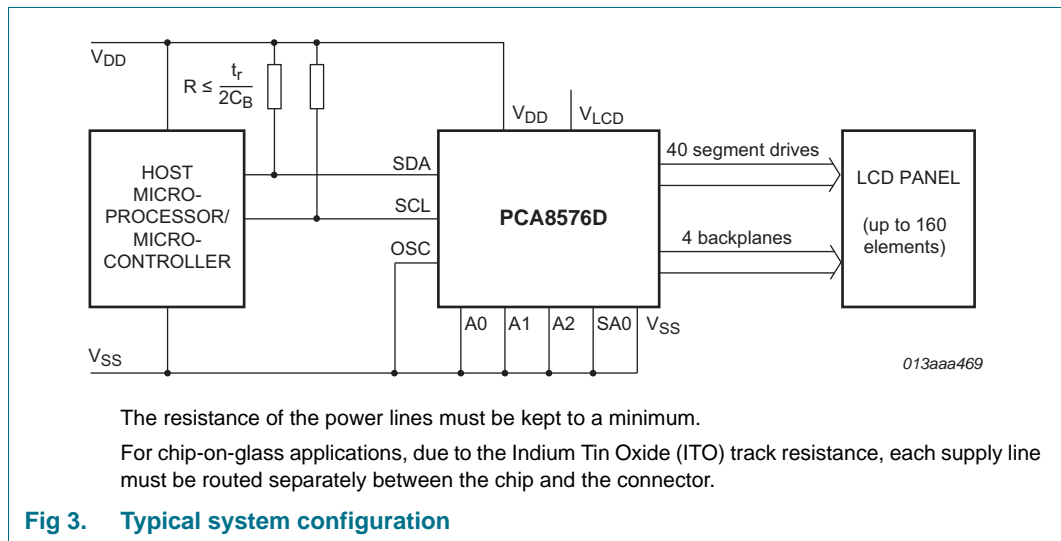

The host microprocessor or microcontroller maintains the 2-line I²C-bus communication channel with the PCA8576D. The internal oscillator is enabled by connecting pin OSC to pin V_{SS}. The appropriate biasing voltages for the multiplexed LCD waveforms are generated internally. The only other connections required to complete the system are to the power supplies (V_{DD}, V_{SS} and V_{LCD}) and the LCD panel chosen for the application.

7.1 Power-on reset

At power-on the PCA8576D resets to the following starting conditions:

- All backplane and segment outputs are set to V_{LCD}
- The selected drive mode is: 1:4 multiplex with $\frac{1}{3}$ bias
- Blinking is switched off
- Input and output bank selectors are reset
- The I²C-bus interface is initialized
- The data pointer and the subaddress counter are cleared (set to logic 0)
- The display is disabled (bit E = 0, see [Table 11](#))

Data transfers on the I²C-bus must be avoided for 1 ms following power-on to allow the reset action to complete.

7.2 LCD bias generator

Fractional LCD biasing voltages are obtained from an internal voltage divider consisting of three impedances connected in series between V_{LCD} and V_{SS} . The middle resistor can be bypassed to provide a $\frac{1}{2}$ bias voltage level for the 1:2 multiplex configuration. The LCD voltage can be temperature compensated externally using the supply to pin V_{LCD} .

7.3 LCD voltage selector

The LCD voltage selector coordinates the multiplexing of the LCD in accordance with the selected LCD drive configuration. The operation of the voltage selector is controlled by the mode-set command (see [Table 11](#)) from the command decoder. The biasing configurations that apply to the preferred modes of operation, together with the biasing characteristics as functions of V_{LCD} and the resulting discrimination ratios (D), are given in [Table 6](#).

Table 6. Discrimination ratios

LCD drive mode	Number of:		LCD bias configuration	$\frac{V_{off(RMS)}}{V_{LCD}}$	$\frac{V_{on(RMS)}}{V_{LCD}}$	$D = \frac{V_{on(RMS)}}{V_{off(RMS)}}$
	Backplanes	Levels				
static	1	2	static	0	1	∞
1:2 multiplex	2	3	$\frac{1}{2}$	0.354	0.791	2.236
1:2 multiplex	2	4	$\frac{1}{3}$	0.333	0.745	2.236
1:3 multiplex	3	4	$\frac{1}{3}$	0.333	0.638	1.915
1:4 multiplex	4	4	$\frac{1}{3}$	0.333	0.577	1.732

A practical value for V_{LCD} is determined by equating $V_{off(RMS)}$ with a defined LCD threshold voltage (V_{th}), typically when the LCD exhibits approximately 10 % contrast. In the static drive mode a suitable choice is $V_{LCD} > 3V_{th}$.

Multiplex drive modes of 1:3 and 1:4 with $\frac{1}{2}$ bias are possible but the discrimination and hence the contrast ratios are smaller.

Bias is calculated by $\frac{1}{1+a}$, where the values for a are

$$a = 1 \text{ for } \frac{1}{2} \text{ bias}$$

$a = 2$ for $\frac{1}{3}$ bias

The RMS on-state voltage ($V_{on(RMS)}$) for the LCD is calculated with [Equation 1](#)

$$V_{on(RMS)} = V_{LCD} \sqrt{\frac{a^2 + 2a + n}{n \times (1 + a)^2}} \quad (1)$$

where the values for n are

$n = 1$ for static mode

$n = 2$ for 1:2 multiplex

$n = 3$ for 1:3 multiplex

$n = 4$ for 1:4 multiplex

The RMS off-state voltage ($V_{off(RMS)}$) for the LCD is calculated with [Equation 2](#):

$$V_{off(RMS)} = V_{LCD} \sqrt{\frac{a^2 - 2a + n}{n \times (1 + a)^2}} \quad (2)$$

Discrimination is the ratio of $V_{on(RMS)}$ to $V_{off(RMS)}$ and is determined from [Equation 3](#):

$$D = \frac{V_{on(RMS)}}{V_{off(RMS)}} = \sqrt{\frac{(a + 1)^2 + (n - 1)}{(a - 1)^2 + (n - 1)}} \quad (3)$$

Using [Equation 3](#), the discrimination for an LCD drive mode of 1:3 multiplex with

$\frac{1}{2}$ bias is $\sqrt{3} = 1.732$ and the discrimination for an LCD drive mode of 1:4 multiplex with

$\frac{1}{2}$ bias is $\frac{\sqrt{21}}{3} = 1.528$.

The advantage of these LCD drive modes is a reduction of the LCD full scale voltage V_{LCD} as follows:

- 1:3 multiplex ($\frac{1}{2}$ bias): $V_{LCD} = \sqrt{6} \times V_{off(RMS)} = 2.449V_{off(RMS)}$

- 1:4 multiplex ($\frac{1}{2}$ bias): $V_{LCD} = \left[\frac{4 \times \sqrt{3}}{3} \right] = 2.309V_{off(RMS)}$

These compare with $V_{LCD} = 3V_{off(RMS)}$ when $\frac{1}{3}$ bias is used.

It should be noted that V_{LCD} is sometimes referred as the LCD operating voltage.

7.3.1 Electro-optical performance

Suitable values for $V_{on(RMS)}$ and $V_{off(RMS)}$ are dependent on the LCD liquid used. The RMS voltage, at which a pixel will be switched on or off, determine the transmissibility of the pixel.

For any given liquid, there are two threshold values defined. One point is at 10 % relative transmission (at V_{low}) and the other at 90 % relative transmission (at V_{high}), see [Figure 4](#). For a good contrast performance, the following rules should be followed:

$$V_{on(RMS)} \geq V_{high} \tag{4}$$

$$V_{off(RMS)} \leq V_{low} \tag{5}$$

$V_{on(RMS)}$ and $V_{off(RMS)}$ are properties of the display driver and are affected by the selection of a , n (see [Equation 1](#) to [Equation 3](#)) and the V_{LCD} voltage.

$V_{th(off)}$ and $V_{th(on)}$ are properties of the LCD liquid and can be provided by the module manufacturer. $V_{th(off)}$ is sometimes just named V_{th} . $V_{th(on)}$ is sometimes named saturation voltage V_{sat} .

It is important to match the module properties to those of the driver in order to achieve optimum performance.

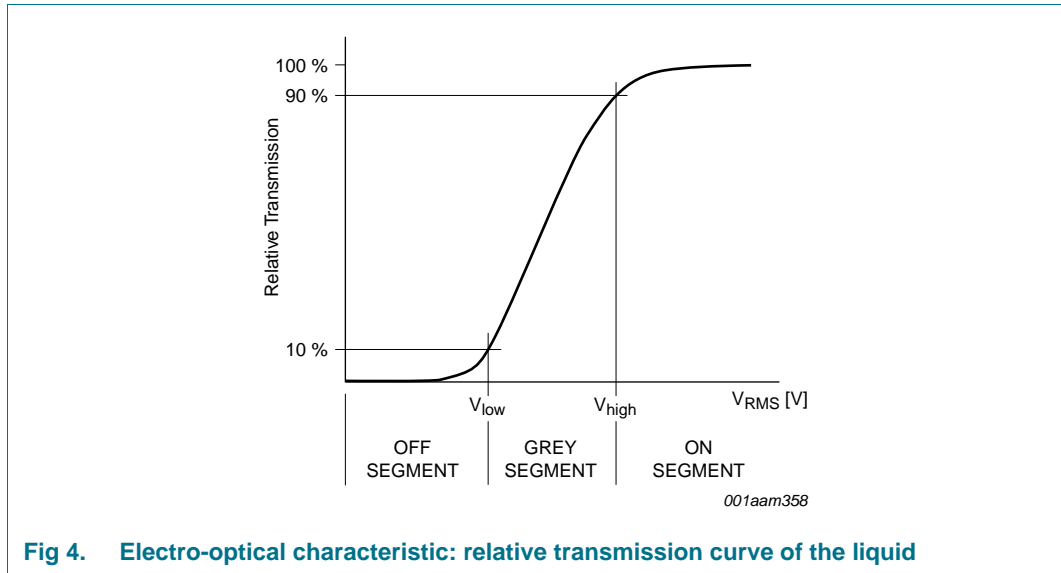
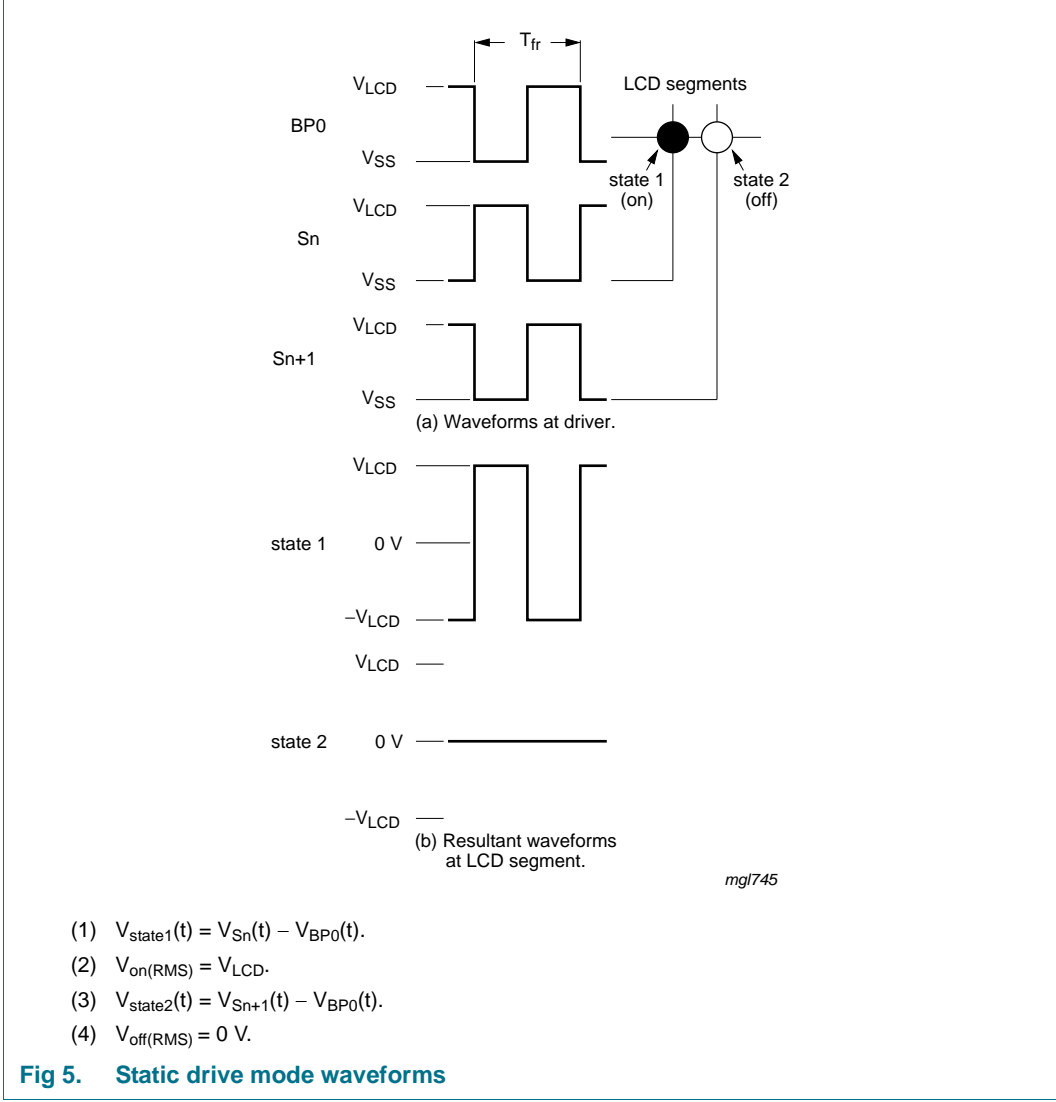

Fig 4. Electro-optical characteristic: relative transmission curve of the liquid

7.4 LCD drive mode waveforms

7.4.1 Static drive mode

The static LCD drive mode is used when a single backplane is provided in the LCD. The backplane (BPn) and segment drive (Sn) waveforms for this mode are shown in [Figure 5](#).



7.4.2 1:2 Multiplex drive mode

The 1:2 multiplex drive mode is used when two backplanes are provided in the LCD. This mode allows fractional LCD bias voltages of $\frac{1}{2}$ bias or $\frac{1}{3}$ bias as shown in [Figure 6](#) and [Figure 7](#).

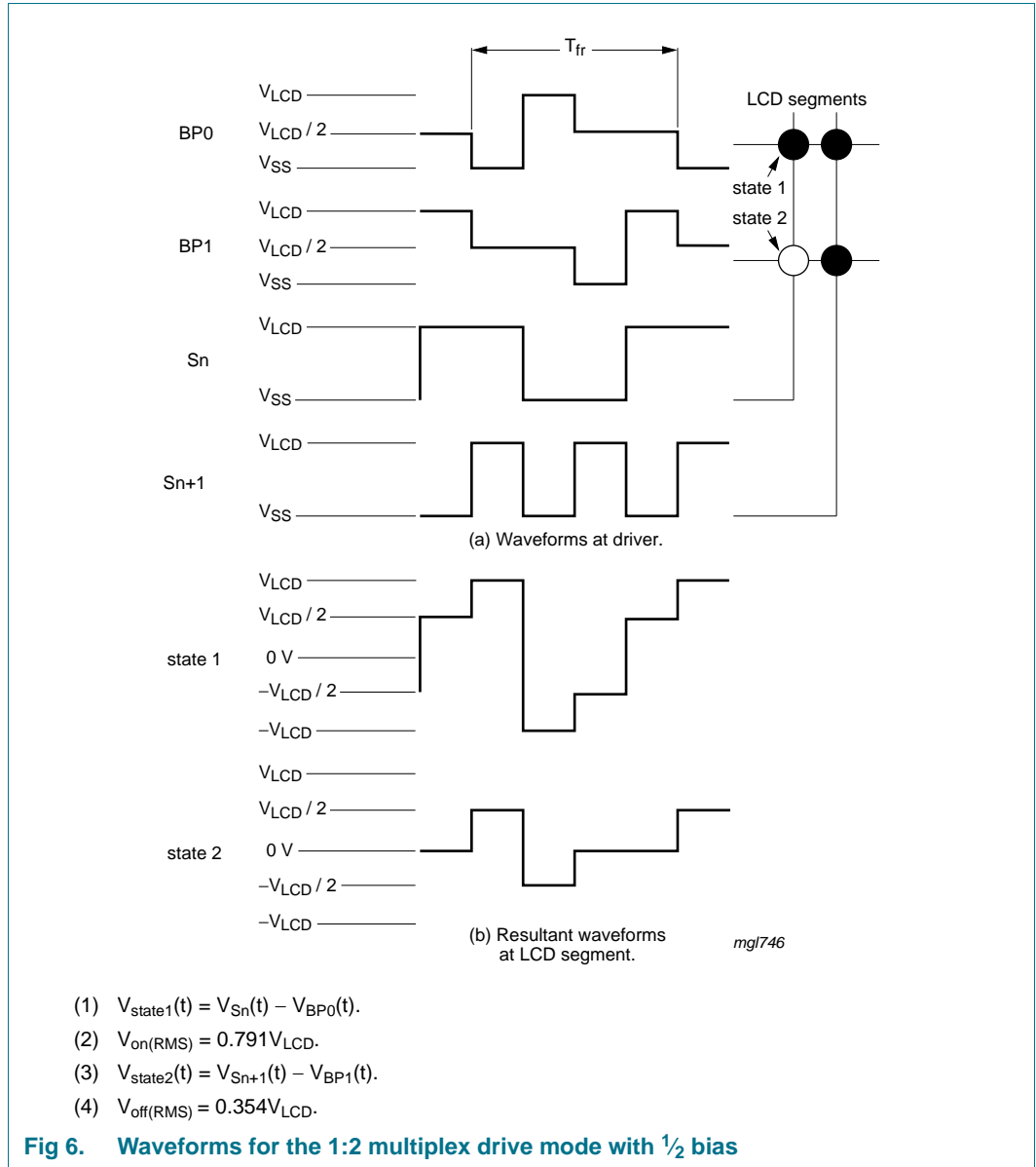
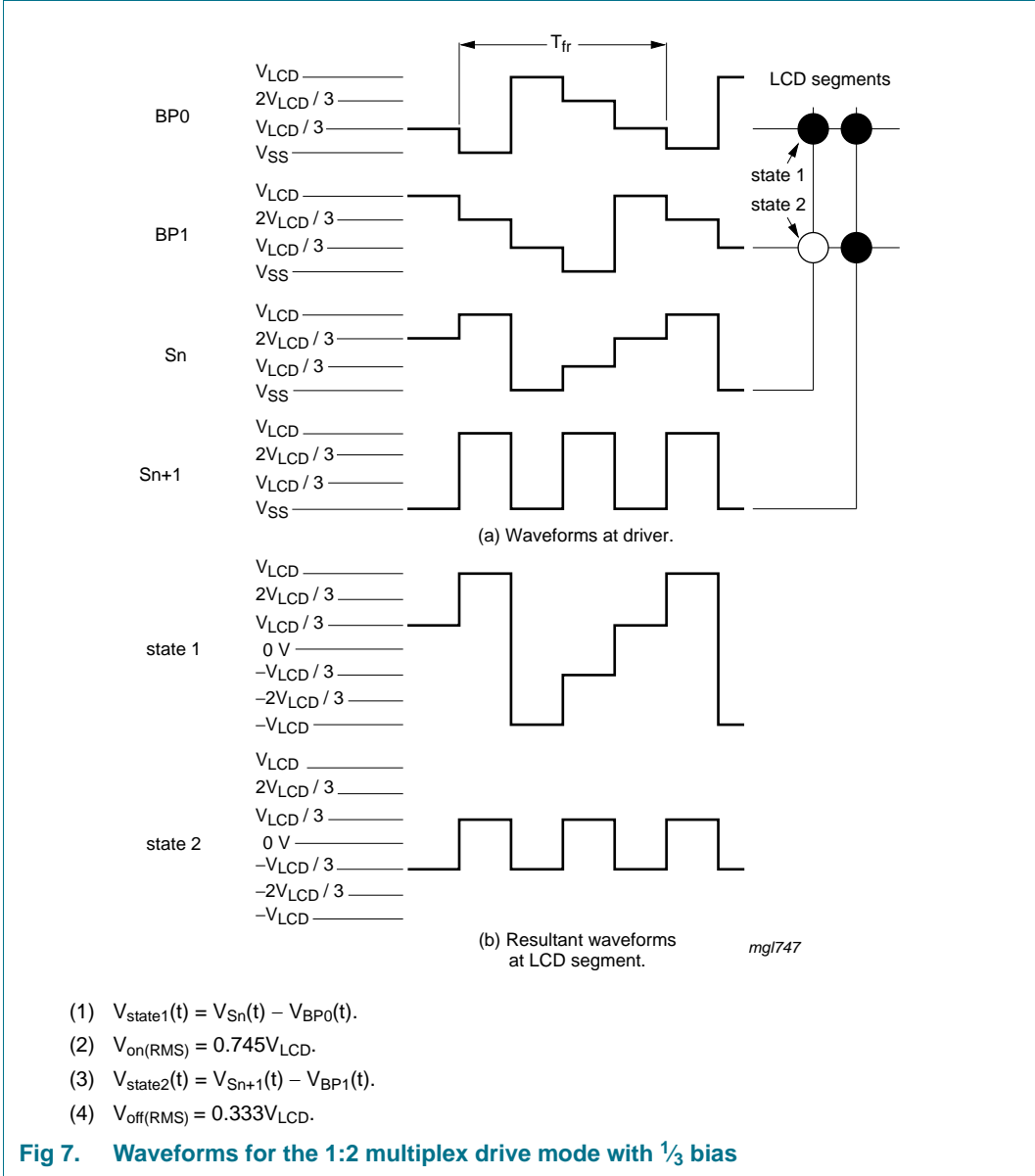

Fig 6. Waveforms for the 1:2 multiplex drive mode with $\frac{1}{2}$ bias



7.4.3 1:3 Multiplex drive mode

When three backplanes are provided in the LCD, the 1:3 multiplex drive mode applies (see Figure 8).

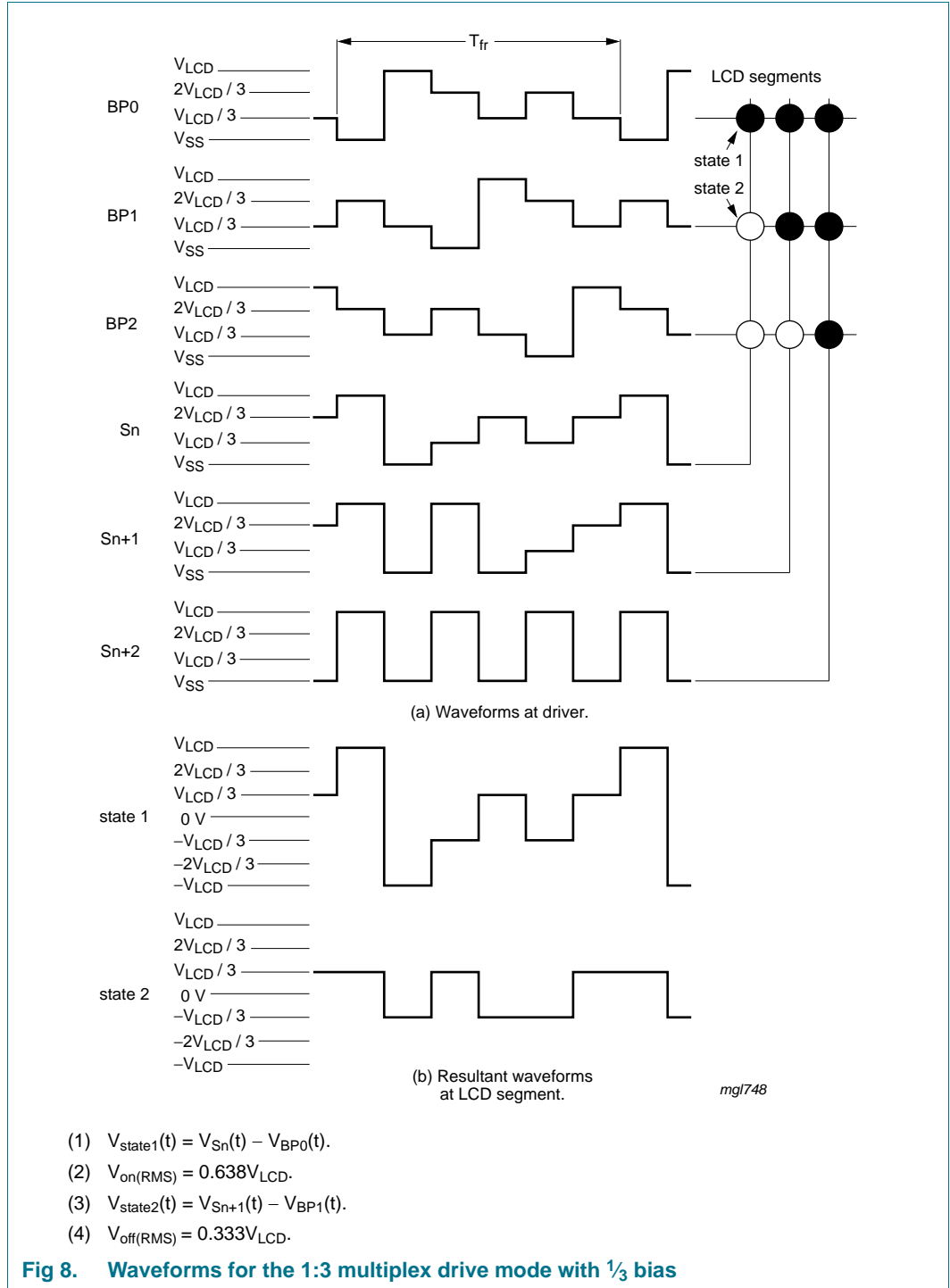
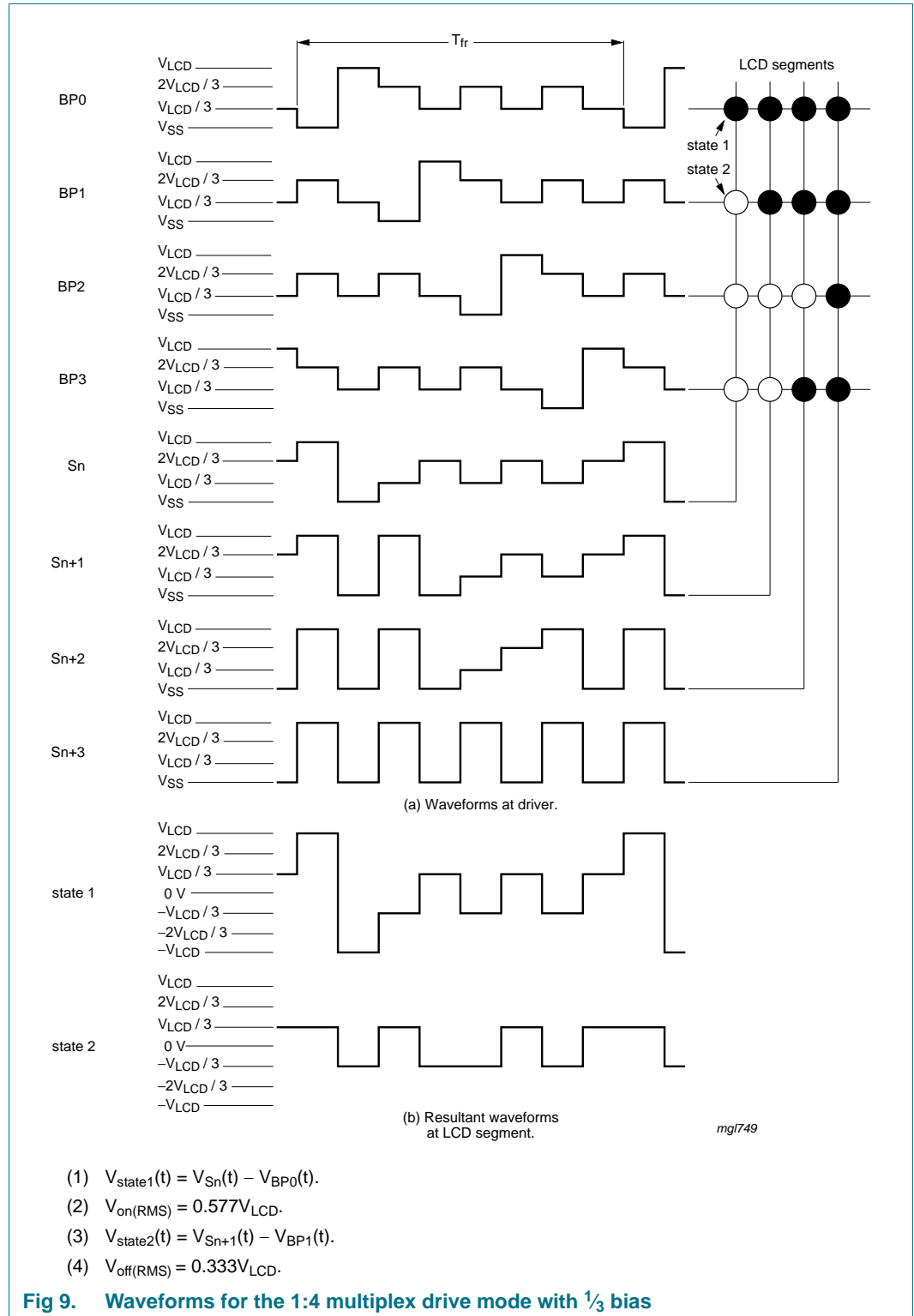

Fig 8. Waveforms for the 1:3 multiplex drive mode with 1/3 bias

7.4.4 1:4 Multiplex drive mode

When four backplanes are provided in the LCD, the 1:4 multiplex drive mode applies (see Figure 9).



7.5 Oscillator

7.5.1 Internal clock

The internal logic of the PCA8576D and its LCD drive signals are timed either by its internal oscillator or by an external clock. The internal oscillator is enabled by connecting pin OSC to pin V_{SS}. If the internal oscillator is used, the output from pin CLK can be used as the clock signal for several PCA8576D in the system that are connected in cascade.

7.5.2 External clock

Pin CLK is enabled as an external clock input by connecting pin OSC to V_{DD}.

The LCD frame signal frequency is determined by the clock frequency (f_{clk}).

Remark: A clock signal must always be supplied to the device; removing the clock may freeze the LCD in a DC state, which is not suitable for the liquid crystal.

7.6 Timing

The PCA8576D timing controls the internal data flow of the device. This includes the transfer of display data from the display RAM to the display segment outputs. In cascaded applications, the correct timing relationship between each PCA8576D in the system is maintained by the synchronization signal at pin SYNC. The timing also generates the LCD frame signal whose frequency is derived from the clock frequency. The frame signal frequency is a fixed division of the clock frequency from either the internal or an external

$$\text{clock: } f_{fr} = \frac{f_{clk}}{24}.$$

7.7 Display register

The display register holds the display data while the corresponding multiplex signals are generated. There is a one-to-one relationship between the data in the display register, the LCD segment outputs, and one column of the display RAM.

7.8 Segment outputs

The LCD drive section includes 40 segment outputs S0 to S39 which should be connected directly to the LCD. The segment output signals are generated in accordance with the multiplexed backplane signals and with data residing in the display register. When less than 40 segment outputs are required, the unused segment outputs should be left open-circuit.

7.9 Backplane outputs

The LCD drive section includes four backplane outputs BP0 to BP3 which must be connected directly to the LCD. The backplane output signals are generated in accordance with the selected LCD drive mode. If less than four backplane outputs are required, the unused outputs can be left open-circuit.

In the 1:3 multiplex drive mode, BP3 carries the same signal as BP1, therefore these two adjacent outputs can be tied together to give enhanced drive capabilities.

drive mode	LCD segments	LCD backplanes	display RAM filling order	transmitted display byte																																																	
static			<p>columns display RAM address/segment outputs (s) byte1</p> <table border="1"> <tr> <td></td> <td>n</td> <td>n+1</td> <td>n+2</td> <td>n+3</td> <td>n+4</td> <td>n+5</td> <td>n+6</td> <td>n+7</td> </tr> <tr> <td>rows display RAM</td> <td>0</td> <td>c</td> <td>b</td> <td>a</td> <td>f</td> <td>g</td> <td>e</td> <td>d</td> <td>DP</td> </tr> <tr> <td>rows/backplane</td> <td>1</td> <td>x</td> <td>x</td> <td>x</td> <td>x</td> <td>x</td> <td>x</td> <td>x</td> <td>x</td> </tr> <tr> <td>outputs (BP)</td> <td>2</td> <td>x</td> <td>x</td> <td>x</td> <td>x</td> <td>x</td> <td>x</td> <td>x</td> <td>x</td> </tr> <tr> <td></td> <td>3</td> <td>x</td> <td>x</td> <td>x</td> <td>x</td> <td>x</td> <td>x</td> <td>x</td> <td>x</td> </tr> </table>		n	n+1	n+2	n+3	n+4	n+5	n+6	n+7	rows display RAM	0	c	b	a	f	g	e	d	DP	rows/backplane	1	x	x	x	x	x	x	x	x	outputs (BP)	2	x	x	x	x	x	x	x	x		3	x	x	x	x	x	x	x	x	<p>MSB</p> <p>LSB</p> <p>c b a f g e d DP</p>
	n	n+1	n+2	n+3	n+4	n+5	n+6	n+7																																													
rows display RAM	0	c	b	a	f	g	e	d	DP																																												
rows/backplane	1	x	x	x	x	x	x	x	x																																												
outputs (BP)	2	x	x	x	x	x	x	x	x																																												
	3	x	x	x	x	x	x	x	x																																												
1:2 multiplex			<p>columns display RAM address/segment outputs (s) byte1</p> <table border="1"> <tr> <td></td> <td>n</td> <td>n+1</td> <td>n+2</td> <td>n+3</td> </tr> <tr> <td>rows display RAM</td> <td>0</td> <td>a</td> <td>f</td> <td>e</td> <td>d</td> </tr> <tr> <td>rows/backplane</td> <td>1</td> <td>b</td> <td>g</td> <td>c</td> <td>DP</td> </tr> <tr> <td>outputs (BP)</td> <td>2</td> <td>x</td> <td>x</td> <td>x</td> <td>x</td> </tr> <tr> <td></td> <td>3</td> <td>x</td> <td>x</td> <td>x</td> <td>x</td> </tr> </table>		n	n+1	n+2	n+3	rows display RAM	0	a	f	e	d	rows/backplane	1	b	g	c	DP	outputs (BP)	2	x	x	x	x		3	x	x	x	x	<p>MSB</p> <p>LSB</p> <p>a b f g e c d DP</p>																				
	n	n+1	n+2	n+3																																																	
rows display RAM	0	a	f	e	d																																																
rows/backplane	1	b	g	c	DP																																																
outputs (BP)	2	x	x	x	x																																																
	3	x	x	x	x																																																
1:3 multiplex			<p>columns display RAM address/segment outputs (s) byte1</p> <table border="1"> <tr> <td></td> <td>n</td> <td>n+1</td> <td>n+2</td> </tr> <tr> <td>rows display RAM</td> <td>0</td> <td>b</td> <td>a</td> <td>f</td> </tr> <tr> <td>rows/backplane</td> <td>1</td> <td>DP</td> <td>d</td> <td>e</td> </tr> <tr> <td>outputs (BP)</td> <td>2</td> <td>c</td> <td>g</td> <td>x</td> </tr> <tr> <td></td> <td>3</td> <td>x</td> <td>x</td> <td>x</td> </tr> </table>		n	n+1	n+2	rows display RAM	0	b	a	f	rows/backplane	1	DP	d	e	outputs (BP)	2	c	g	x		3	x	x	x	<p>MSB</p> <p>LSB</p> <p>b DP c a d g f e</p>																									
	n	n+1	n+2																																																		
rows display RAM	0	b	a	f																																																	
rows/backplane	1	DP	d	e																																																	
outputs (BP)	2	c	g	x																																																	
	3	x	x	x																																																	
1:4 multiplex			<p>columns display RAM address/segment outputs (s) byte1</p> <table border="1"> <tr> <td></td> <td>n</td> <td>n+1</td> </tr> <tr> <td>rows display RAM</td> <td>0</td> <td>a</td> <td>f</td> </tr> <tr> <td>rows/backplane</td> <td>1</td> <td>c</td> <td>e</td> </tr> <tr> <td>outputs (BP)</td> <td>2</td> <td>b</td> <td>g</td> </tr> <tr> <td></td> <td>3</td> <td>DP</td> <td>d</td> </tr> </table>		n	n+1	rows display RAM	0	a	f	rows/backplane	1	c	e	outputs (BP)	2	b	g		3	DP	d	<p>MSB</p> <p>LSB</p> <p>a c b DP f e g d</p>																														
	n	n+1																																																			
rows display RAM	0	a	f																																																		
rows/backplane	1	c	e																																																		
outputs (BP)	2	b	g																																																		
	3	DP	d																																																		

001aaj646

x = data bit unchanged.

Fig 11. Relationship between LCD layout, drive mode, display RAM filling order and display data transmitted over the I²C-bus

The following applies to [Figure 11](#):

- In static drive mode the eight transmitted data bits are placed in row 0 as one byte.
- In 1:2 multiplex drive mode the eight transmitted data bits are placed in pairs into row 0 and 1 as two successive 4-bit RAM words.
- In 1:3 multiplex drive mode the eight bits are placed in triples into row 0, 1, and 2 as three successive 3-bit RAM words, with bit 3 of the third address left unchanged. It is not recommended to use this bit in a display because of the difficult addressing. This last bit may, if necessary, be controlled by an additional transfer to this address but care should be taken to avoid overwriting adjacent data because always full bytes are transmitted.
- In 1:4 multiplex drive mode, the eight transmitted data bits are placed in quadruples into row 0, 1, 2, and 3 as two successive 4-bit RAM words.

7.11 Data pointer

The addressing mechanism for the display RAM is realized using the data pointer.

This allows the loading of an individual display data byte, or a series of display data bytes, into any location of the display RAM. The sequence commences with the initialization of the data pointer by the load-data-pointer command (see [Section 7.17](#)).

Following this command, an arriving data byte is stored at the display RAM address indicated by the data pointer. The filling order is shown in [Figure 11](#).

After each byte is stored, the content of the data pointer is automatically incremented by a value dependent on the selected LCD drive mode:

After each byte is stored, the contents of the data pointer is automatically incremented by a value dependent on the selected LCD drive mode:

- In static drive mode by eight
- In 1:2 multiplex drive mode by four
- In 1:3 multiplex drive mode by three
- In 1:4 multiplex drive mode by two

If an I²C-bus data access is terminated early then the state of the data pointer is unknown. The data pointer should be re-written prior to further RAM accesses.

7.12 Subaddress counter

The storage of display data is determined by the contents of the subaddress counter. Storage is allowed to take place only when the contents of the subaddress counter match with the hardware subaddress applied to A0, A1 and A2. The subaddress counter value is defined by the device-select command (see [Section 7.17](#)). If the contents of the subaddress counter and the hardware subaddress do not match then data storage is inhibited but the data pointer is incremented as if data storage had taken place. The subaddress counter is also incremented when the data pointer overflows.

The storage arrangements described lead to extremely efficient data loading in cascaded applications. When a series of display bytes are sent to the display RAM, automatic wrap-over to the next PCA8576D occurs when the last RAM address is exceeded.

Subaddressing across device boundaries is successful even if the change to the next device in the cascade occurs within a transmitted character (such as during the 14th display data byte transmitted in 1:3 multiplex mode).

The hardware subaddress must not be changed while the device is being accessed on the I²C-bus interface.

7.13 Output bank selector

The output bank selector (see [Table 14](#)) selects one of the four rows per display RAM address for transfer to the display register. The actual row selected depends on the particular LCD drive mode in operation and on the instant in the multiplex sequence.

- In 1:4 multiplex mode, all RAM addresses of row 0 are selected, these are followed by the contents of row 1, 2, and then 3
- In 1:3 multiplex mode, rows 0, 1, and 2 are selected sequentially
- In 1:2 multiplex mode, rows 0 and 1 are selected
- In static mode, row 0 is selected

The $\overline{\text{SYNC}}$ signal resets these sequences to the following starting points: row 3 for 1:4 multiplex, row 2 for 1:3 multiplex, row 1 for 1:2 multiplex and row 0 for static mode.

The PCA8576D includes a RAM bank switching feature in the static and 1:2 multiplex drive modes. In the static drive mode, the bank-select command may request the contents of row 2 to be selected for display instead of the contents of row 0. In the 1:2 mode, the contents of rows 2 and 3 may be selected instead of rows 0 and 1. This gives the provision for preparing display information in an alternative bank and to be able to switch to it, once it is assembled.

7.14 Input bank selector

The input bank selector loads display data into the display RAM in accordance with the selected LCD drive configuration. Display data can be loaded in row 2 in static drive mode or in rows 2 and 3 in 1:2 multiplex drive mode by using the bank-select command. The input bank selector functions independently to the output bank selector.

7.15 Blinking

The PCA8576D has a very versatile display blinking capability. The whole display can blink at a frequency selected by the blink-select command (see [Table 15](#)). Each blink frequency is a fraction of the clock frequency; the ratio between the clock frequency and blink frequency depends on the blink mode selected (see [Table 7](#)).

An additional feature allows an arbitrary selection of LCD segments to blink in the static and 1:2 drive modes. This is implemented without any communication overheads by the output bank selector which alternates the displayed data between the data in the display RAM bank and the data in an alternative RAM bank at the blink frequency. This mode can also be implemented by the blink-select command (see [Table 15](#)).

In the 1:3 and 1:4 drive modes, where no alternative RAM bank is available, groups of LCD segments can blink selectively by changing the display RAM data at fixed time intervals.

The entire display can blink at a frequency other than the nominal blink frequency by sequentially resetting and setting the display enable bit E at the required rate using the mode-set command (see [Table 11](#)).

Table 7. Blinking frequencies^[1]

Blink mode	Normal operating mode ratio	Nominal blink frequency
off	-	blinking off
1	$\frac{f_{clk}}{768}$	2 Hz
2	$\frac{f_{clk}}{1536}$	1 Hz
3	$\frac{f_{clk}}{3072}$	0.5 Hz

[1] Blink modes 1, 2 and 3 and the nominal blink frequencies 0.5 Hz, 1 Hz and 2 Hz correspond to an oscillator frequency (f_{clk}) of 1536 Hz (see [Section 11](#)).

7.16 Characteristics of the I²C-bus

The I²C-bus is for bidirectional, two-line communication between different ICs or modules. The two lines are a Serial DATA line (SDA) and a Serial CLOCK line (SCL). Both lines must be connected to a positive supply via a pull-up resistor when connected to the output stages of a device. Data transfer may be initiated only when the bus is not busy.

7.16.1 Bit transfer

One data bit is transferred during each clock pulse. The data on the SDA line must remain stable during the HIGH period of the clock pulse as changes in the data line at this time will be interpreted as a control signal (see [Figure 12](#)).

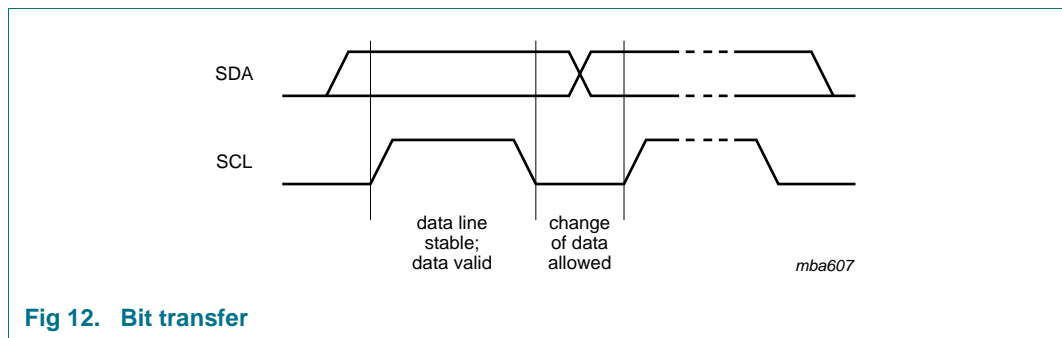

Fig 12. Bit transfer

7.16.2 START and STOP conditions

Both data and clock lines remain HIGH when the bus is not busy.

A HIGH-to-LOW transition of the data line while the clock is HIGH is defined as the START condition - S.

A LOW-to-HIGH transition of the data line while the clock is HIGH is defined as the STOP condition - P (see [Figure 13](#)).

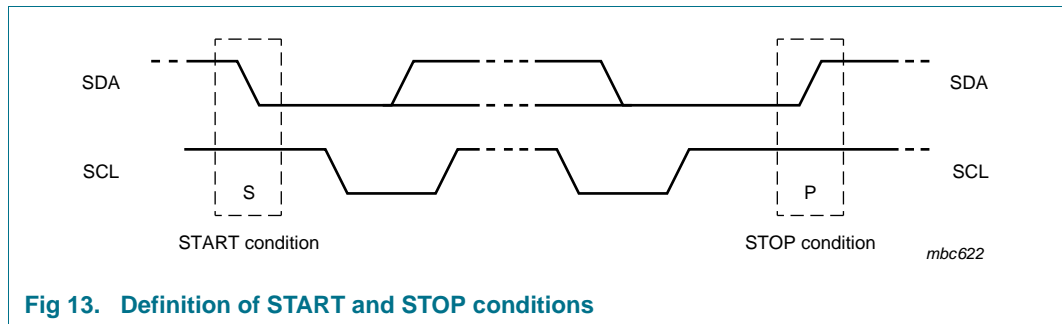

Fig 13. Definition of START and STOP conditions

7.16.3 System configuration

A device generating a message is a transmitter, a device receiving a message is the receiver. The device that controls the message is the master and the devices which are controlled by the master are the slaves (see [Figure 14](#)).

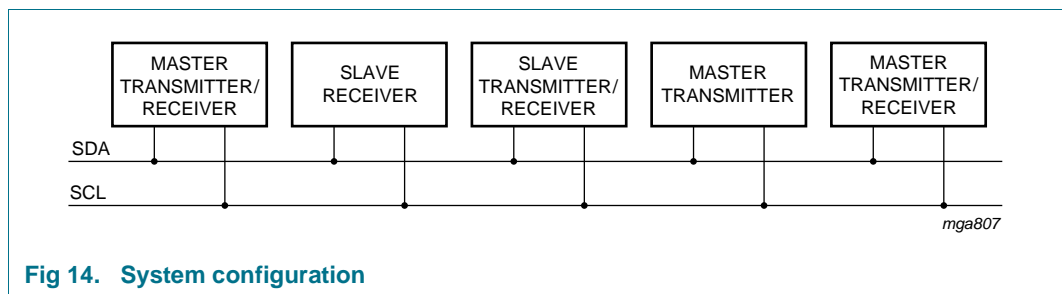

Fig 14. System configuration

7.16.4 Acknowledge

The number of data bytes transferred between the START and STOP conditions from transmitter to receiver is unlimited. Each byte of eight bits is followed by an acknowledge cycle.

- A slave receiver which is addressed must generate an acknowledge after the reception of each byte.
- Also a master receiver must generate an acknowledge after the reception of each byte that has been clocked out of the slave transmitter.
- The device that acknowledges must pull-down the SDA line during the acknowledge clock pulse, so that the SDA line is stable LOW during the HIGH period of the acknowledge related clock pulse (set-up and hold times must be taken into consideration).

- A master receiver must signal an end of data to the transmitter by not generating an acknowledge on the last byte that has been clocked out of the slave. In this event the transmitter must leave the data line HIGH to enable the master to generate a STOP condition.

Acknowledgement on the I²C-bus is shown in [Figure 15](#).

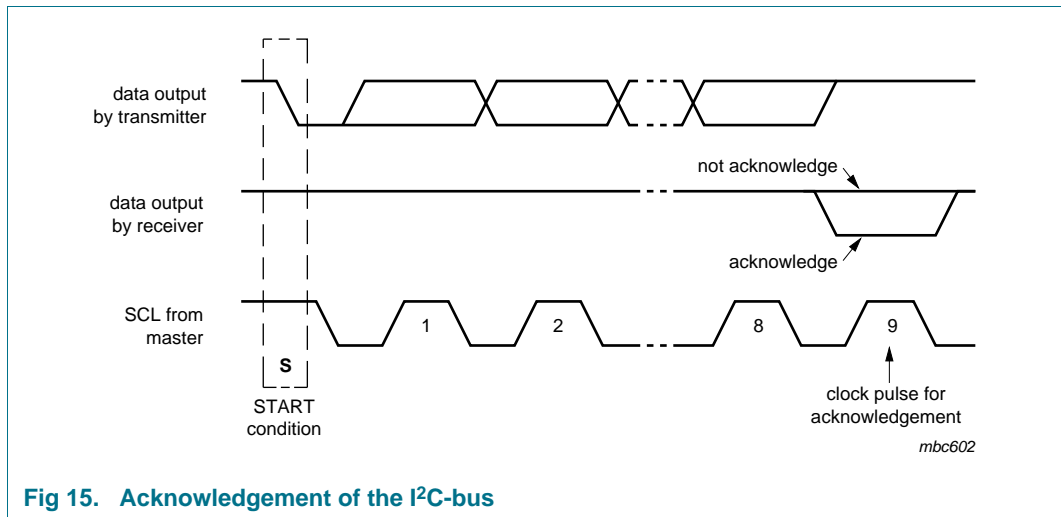

Fig 15. Acknowledgement of the I²C-bus

7.16.5 I²C-bus controller

The PCA8576D acts as an I²C-bus slave receiver. It does not initiate I²C-bus transfers or transmit data to an I²C-bus master receiver. The only data output from the PCA8576D are the acknowledge signals of the selected devices. Device selection depends on the I²C-bus slave address, on the transferred command data and on the hardware subaddress.

In single device applications, the hardware subaddress inputs A0, A1 and A2 are normally tied to V_{SS} which defines the hardware subaddress 0. In multiple device applications A0, A1 and A2 are tied to V_{SS} or V_{DD} in accordance with a binary coding scheme such that no two devices with a common I²C-bus slave address have the same hardware subaddress.

7.16.6 Input filters

To enhance noise immunity in electrically adverse environments, RC low-pass filters are provided on the SDA and SCL lines.

7.16.7 I²C-bus protocol

Two I²C-bus slave addresses (0111 000 and 0111 001) are reserved for the PCA8576D.

The PCA8576D slave address is illustrated in [Table 8](#).

Table 8. I²C slave address byte

Bit	Slave address							0 LSB
	7 MSB	6	5	4	3	2	1	
	0	1	1	1	0	0	SA0	R/W

The least significant bit of the slave address that a PCA8576D will respond to is defined by the level tied to its SA0 input. The PCA8576D is a write-only device and will not respond to a read access. Having two reserved slave addresses allows the following on the same I²C-bus:

- Up to 16 PCA8576D for very large LCD applications
- The use of two types of LCD multiplex drive modes.

The I²C-bus protocol is shown in [Figure 16](#). The sequence is initiated with a START condition (S) from the I²C-bus master which is followed by one of two possible PCA8576D slave addresses available. All PCA8576D whose SA0 inputs correspond to bit 0 of the slave address respond by asserting an acknowledge in parallel. This I²C-bus transfer is ignored by all PCA8576D whose SA0 inputs are set to the alternative level.

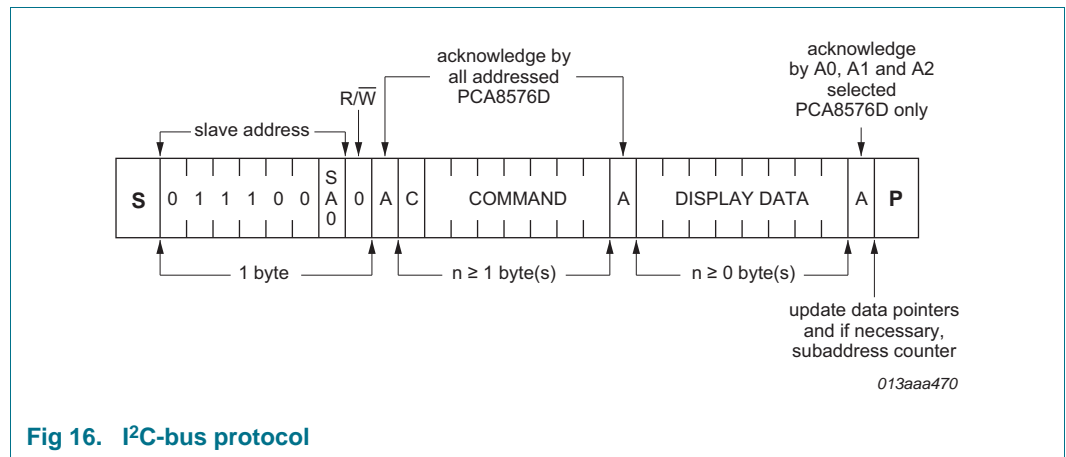

Fig 16. I²C-bus protocol

After an acknowledgement, one or more command bytes follow, that define the status of each addressed PCA8576D.

The last command byte sent is identified by resetting its most significant bit, continuation bit C, (see [Figure 17](#)). The command bytes are also acknowledged by all addressed PCA8576D on the bus.

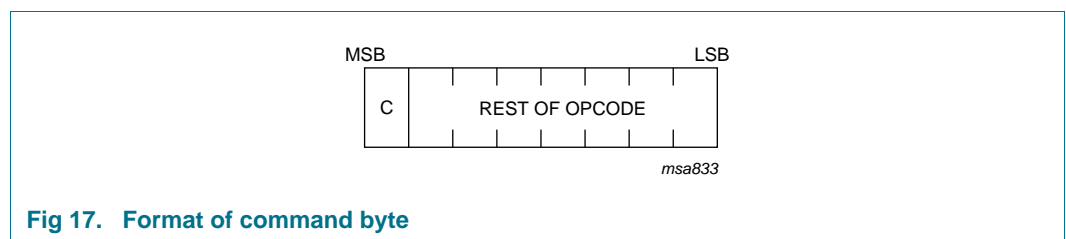

Fig 17. Format of command byte

After the last command byte, one or more display data bytes may follow. Display data bytes are stored in the display RAM at the address specified by the data pointer and the subaddress counter. Both data pointer and subaddress counter are automatically updated and the data directed to the intended PCA8576D device.

An acknowledgement after each byte is asserted only by the PCA8576D that are addressed via address lines A0, A1 and A2. After the last display byte, the I²C-bus master asserts a STOP condition (P). Alternately a START may be asserted to restart an I²C-bus access.

7.17 Command decoder

The command decoder identifies command bytes that arrive on the I²C-bus. The commands available to the PCA8576D are defined in [Table 9](#).

Table 9. Definition of PCA8576D commands

Command	Operation Code								Reference
	7	6	5	4	3	2	1	0	
mode-set	C	1	0	1	E	B	M[1:0]		Table 11
load-data-pointer	C	0	P[5:0]						Table 12
device-select	C	1	1	0	0	A[2:0]			Table 13
bank-select	C	1	1	1	1	0	I	O	Table 14
blink-select	C	1	1	1	0	AB	BF[1:0]		Table 15

[1] Not used.

All available commands carry a continuation bit C in their most significant bit position as shown in [Figure 17](#). When this bit is set, it indicates that the next byte of the transfer to arrive will also represent a command. If this bit is reset, it indicates that the command byte is the last in the transfer. Further bytes will be regarded as display data (see [Table 10](#)).

Table 10. C bit description

Bit	Symbol	Value	Description
7	C		continue bit
		0	last control byte in the transfer; next byte will be regarded as display data
		1	control bytes continue; next byte will be a command too

Table 11. Mode-set command bit description

Bit	Symbol	Value	Description
7	C	0, 1	see Table 10
6 to 5	-	10	fixed value
4	-	-	unused
3	E		display status [1]
		0 [2]	disabled (blank) [3]
		1	enabled
2	B		LCD bias configuration [4]
		0 [2]	1/3 bias
		1	1/2 bias
1 to 0	M[1:0]		LCD drive mode selection
		01	static; BP0
		10	1:2 multiplex; BP0, BP1
		11	1:3 multiplex; BP0, BP1, BP2
		00 [2]	1:4 multiplex; BP0, BP1, BP2, BP3

[1] The possibility to disable the display allows implementation of blinking under external control.

[2] Default value.

[3] The display is disabled by setting all backplane and segment outputs to V_{LCD}.

[4] Not applicable for static drive mode.

Table 12. Load-data-pointer command bit description

Bit	Symbol	Value	Description
7	C	0, 1	see Table 10
6	-	0	fixed value
5 to 0	P[5:0]	000000 ^[1] to 100111	6 bit binary value, 0 to 39; transferred to the data pointer to define one of forty display RAM addresses

[1] Default value.

Table 13. Device-select command bit description

Bit	Symbol	Value	Description
7	C	0, 1	see Table 10
6 to 3	-	1100	fixed value
2 to 0	A[2:0]	000 ^[1] to 111	3 bit binary value, 0 to 7; transferred to the subaddress counter to define one of eight hardware subaddresses

[1] Default value.

Table 14. Bank-select command bit description

Bit	Symbol	Value	Description	
			Static	1:2 multiplex ^[1]
7	C	0, 1	see Table 10	
6 to 2	-	11110	fixed value	
1	I		input bank selection ; storage of arriving display data	
		0 ^[2]	RAM bit 0	RAM bits 0 and 1
		1	RAM bit 2	RAM bits 2 and 3
0	O		output bank selection ; retrieval of LCD display data	
		0 ^[2]	RAM bit 0	RAM bits 0 and 1
		1	RAM bit 2	RAM bits 2 and 3

[1] The bank-select command has no effect in 1:3 and 1:4 multiplex drive modes.

[2] Default value.

Table 15. Blink-select command bit description

Bit	Symbol	Value	Description
7	C	0, 1	see Table 10
6 to 3	-	1110	fixed value
2	AB		blink mode selection
		0 ^[1]	normal blinking ^[2]
		1	alternate RAM bank blinking ^[3]
1 to 0	BF[1:0]		blink frequency selection
		00 ^[1]	off
		01	1
		10	2
		11	3

[1] Default value.

[2] Normal blinking is assumed when the LCD multiplex drive modes 1:3 or 1:4 are selected.

[3] Alternate RAM bank blinking does not apply in 1:3 and 1:4 multiplex drive modes.

7.18 Display controller

The display controller executes the commands identified by the command decoder. It contains the device's status registers and coordinates their effects. The display controller is also responsible for loading display data into the display RAM in the correct filling order.

8. Internal circuitry

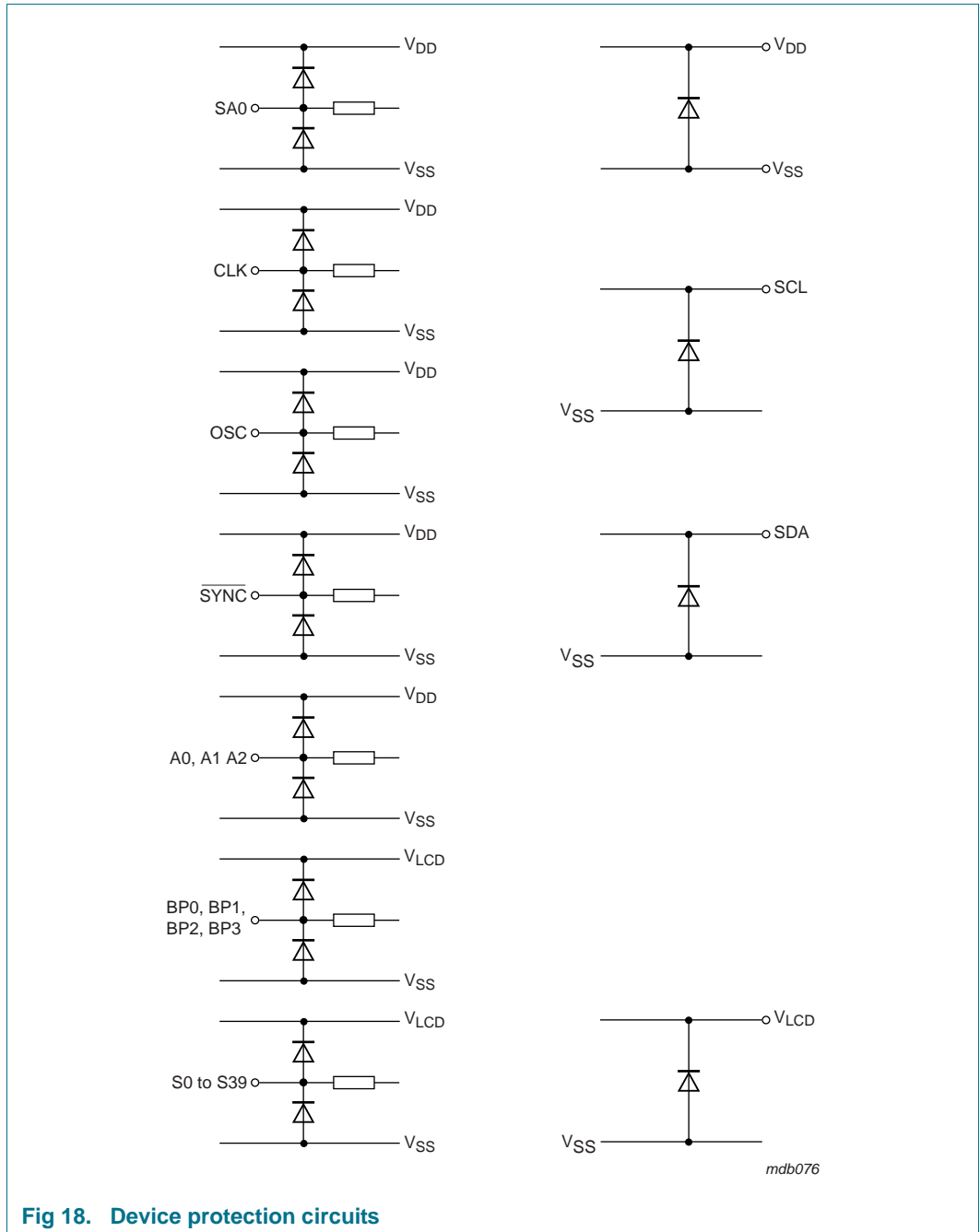

Fig 18. Device protection circuits

9. Limiting values

CAUTION



Static voltages across the liquid crystal display can build up when the LCD supply voltage (V_{LCD}) is on while the IC supply voltage (V_{DD}) is off, or vice versa. This may cause unwanted display artifacts. To avoid such artifacts, V_{LCD} and V_{DD} must be applied or removed together.

Table 16. Limiting values

In accordance with the Absolute Maximum Rating System (IEC 60134).

Symbol	Parameter	Conditions	Min	Max	Unit	
V_{DD}	supply voltage		-0.5	+6.5	V	
V_{LCD}	LCD supply voltage		-0.5	+7.5	V	
V_I	input voltage	on each of the pins CLK, SDA, SCL, SYNC, SA0, OSC, A0 to A2	-0.5	+6.5	V	
V_O	output voltage	on each of the pins S0 to S39, BP0 to BP3	-0.5	+7.5	V	
I_I	input current		-10	+10	mA	
I_O	output current		-10	+10	mA	
I_{DD}	supply current		-50	+50	mA	
$I_{DD(LCD)}$	LCD supply current		-50	+50	mA	
I_{SS}	ground supply current		-50	+50	mA	
P_{tot}	total power dissipation		-	400	mW	
P_o	output power		-	100	mW	
V_{ESD}	electrostatic discharge voltage	HBM	[1]	-	±5000	V
		MM	[2]	-	±200	V
I_{lu}	latch-up current		[3]	-	100	mA
T_{stg}	storage temperature		[4]	-65	+150	°C
T_{amb}	ambient temperature	operating device		-40	+85	°C

[1] Pass level; Human Body Model (HBM) according to [Ref. 6 "JESD22-A114"](#).

[2] Pass level; Machine Model (MM), according to [Ref. 7 "JESD22-A115"](#).

[3] Pass level; latch-up testing according to [Ref. 8 "JESD78"](#) at maximum ambient temperature ($T_{amb(max)}$).

[4] According to the store and transport requirements (see [Ref. 11 "UM10569"](#)) the devices have to be stored at a temperature of +8 °C to +45 °C and a humidity of 25 % to 75 %.

10. Static characteristics

Table 17. Static characteristics

$V_{DD} = 1.8\text{ V to }5.5\text{ V}$; $V_{SS} = 0\text{ V}$; $V_{LCD} = 2.5\text{ V to }6.5\text{ V}$; $T_{amb} = -40\text{ °C to }+85\text{ °C}$; unless otherwise specified.

Symbol	Parameter	Conditions	Min	Typ	Max	Unit	
Supplies							
V_{DD}	supply voltage		1.8	-	5.5	V	
V_{LCD}	LCD supply voltage		[1]	-	6.5	V	
I_{DD}	supply current	$f_{clk(ext)} = 1536\text{ Hz}$	[2]	-	3.5	7	μA
		$V_{DD} = 3.0\text{ V}$; $T_{amb} = 25\text{ °C}$		-	2.7	-	μA
$I_{DD(LCD)}$	LCD supply current	$f_{clk(ext)} = 1536\text{ Hz}$	[2]	-	18	25	μA
		$V_{LCD} = 3.0\text{ V}$; $T_{amb} = 25\text{ °C}$		-	13	-	μA
Logic[3]							
$V_{P(POR)}$	power-on reset supply voltage		1.0	1.3	1.6	V	
V_{IL}	LOW-level input voltage	on pins CLK, $\overline{\text{SYNC}}$, OSC, A0 to A2, SA0, SCL, SDA	V_{SS}	-	$0.3V_{DD}$	V	
V_{IH}	HIGH-level input voltage	on pins CLK, $\overline{\text{SYNC}}$, OSC, A0 to A2, SA0, SCL, SDA	[4][5]	$0.7V_{DD}$	-	V_{DD}	V
I_{OL}	LOW-level output current	output sink current; $V_{OL} = 0.4\text{ V}$; $V_{DD} = 5\text{ V}$					
		on pins CLK and $\overline{\text{SYNC}}$	1	-	-	mA	
		on pin SDA	3	-	-	mA	
$I_{OH(CLK)}$	HIGH-level output current on pin CLK	output source current; $V_{OH} = 4.6\text{ V}$; $V_{DD} = 5\text{ V}$	1	-	-	mA	
I_L	leakage current	$V_I = V_{DD}$ or V_{SS} ; on pins CLK, SCL, SDA, A0 to A2 and SA0	-1	-	+1	μA	
$I_{L(OSC)}$	leakage current on pin OSC	$V_I = V_{DD}$	-1	-	+1	μA	
C_I	input capacitance		[6]	-	7	pF	
LCD outputs							
ΔV_O	output voltage variation	on pins BP0 to BP3 and S0 to S39	-100	-	+100	mV	
R_O	output resistance	$V_{LCD} = 5\text{ V}$	[7]				
		on pins BP0 to BP3	-	1.5	-	k Ω	
		on pins S0 to S39	-	6.0	-	k Ω	

[1] $V_{LCD} > 3\text{ V}$ for $\frac{1}{3}$ bias.

[2] LCD outputs are open-circuit; inputs at V_{SS} or V_{DD} ; external clock with 50 % duty factor; I²C-bus inactive.

[3] The I²C-bus interface of PCA8576D is 5 V tolerant.

[4] When tested, I²C pins SCL and SDA have no diode to V_{DD} and may be driven to the V_I limiting values given in [Table 16](#).

[5] Propagation delay of driver between clock (CLK) and LCD driving signals.

[6] Periodically sampled, not 100 % tested.

[7] Outputs measured one at a time.

11. Dynamic characteristics

Table 18. Dynamic characteristics

$V_{DD} = 1.8\text{ V to }5.5\text{ V}$; $V_{SS} = 0\text{ V}$; $V_{LCD} = 2.5\text{ V to }6.5\text{ V}$; $T_{amb} = -40\text{ }^{\circ}\text{C to }+85\text{ }^{\circ}\text{C}$; unless otherwise specified.

Symbol	Parameter	Conditions	Min	Typ	Max	Unit
Clock						
$f_{clk(int)}$	internal clock frequency	[1]	1440	1850	2640	Hz
$f_{clk(ext)}$	external clock frequency		960	-	2640	Hz
$t_{clk(H)}$	HIGH-level clock time		60	-	-	μs
$t_{clk(L)}$	LOW-level clock time		60	-	-	μs
Synchronization						
$t_{PD(SYNC_N)}$	$\overline{\text{SYNC}}$ propagation delay		-	30	-	ns
t_{SYNC_NL}	$\overline{\text{SYNC}}$ LOW time		1	-	-	μs
$t_{PD(drv)}$	driver propagation delay	$V_{LCD} = 5\text{ V}$ [2]	-	-	30	μs
I²C-bus[3]						
Pin SCL						
f_{SCL}	SCL clock frequency		-	-	400	kHz
t_{LOW}	LOW period of the SCL clock		1.3	-	-	μs
t_{HIGH}	HIGH period of the SCL clock		0.6	-	-	μs
Pin SDA						
$t_{SU;DAT}$	data set-up time		100	-	-	ns
$t_{HD;DAT}$	data hold time		0	-	-	ns
Pins SCL and SDA						
t_{BUF}	bus free time between a STOP and START condition		1.3	-	-	μs
$t_{SU;STO}$	set-up time for STOP condition		0.6	-	-	μs
$t_{HD;STA}$	hold time (repeated) START condition		0.6	-	-	μs
$t_{SU;STA}$	set-up time for a repeated START condition		0.6	-	-	μs
t_r	rise time of both SDA and SCL signals	$f_{SCL} = 400\text{ kHz}$	-	-	0.3	μs
		$f_{SCL} < 125\text{ kHz}$	-	-	1.0	μs
t_f	fall time of both SDA and SCL signals		-	-	0.3	μs
C_b	capacitive load for each bus line		-	-	400	pF
$t_{w(spike)}$	spike pulse width	on the I ² C-bus	-	-	50	ns

[1] Typical output duty factor: 50 % measured at the CLK output pin.

[2] Not tested in production.

[3] All timing values are valid within the operating supply voltage and ambient temperature range and are referenced to V_{IL} and V_{IH} with an input voltage swing of V_{SS} to V_{DD} .

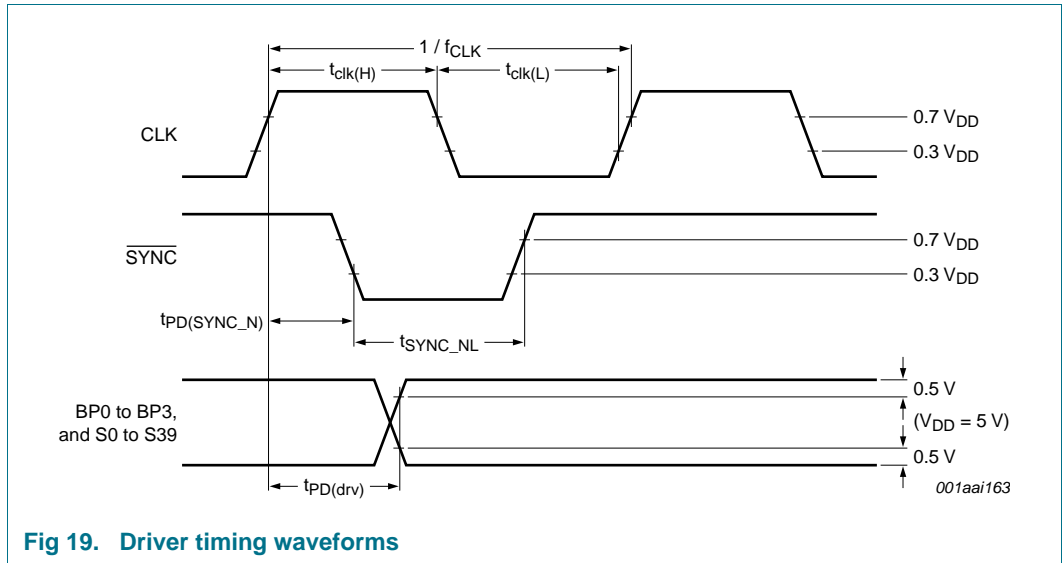

Fig 19. Driver timing waveforms

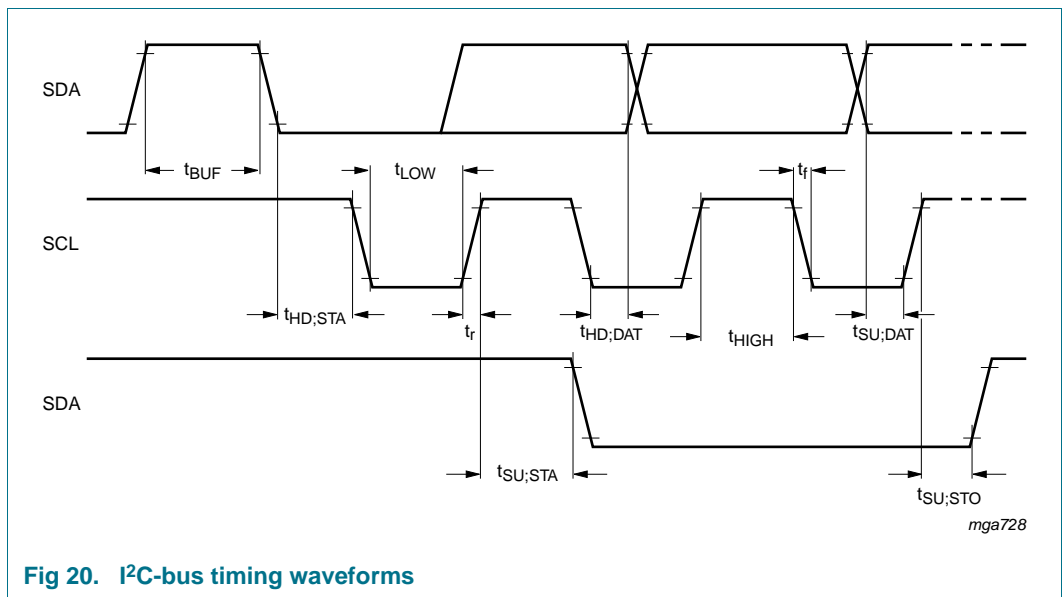

Fig 20. I²C-bus timing waveforms

12. Application information

12.1 Cascaded operation

In large display configurations, up to 16 PCA8576D can be differentiated on the same I²C-bus by using the 3-bit hardware subaddresses (A0, A1 and A2) and the programmable I²C-bus slave address (SA0).

Table 19. Addressing cascaded PCA8576D

Cluster	Bit SA0	Pin A2	Pin A1	Pin A0	Device
1	0	0	0	0	0
		0	0	1	1
		0	1	0	2
		0	1	1	3
		1	0	0	4
		1	0	1	5
		1	1	0	6
		1	1	1	7
2	1	0	0	0	8
		0	0	1	9
		0	1	0	10
		0	1	1	11
		1	0	0	12
		1	0	1	13
		1	1	0	14
		1	1	1	15

The PCA8576D connected in cascade are synchronized to allow the backplane signals from only one device in the cascade to be shared. This arrangement is cost-effective in large LCD applications since the backplane outputs of only one device need to be through-plated to the backplane electrodes of the display. The other cascaded PCA8576D contribute additional segment outputs but their backplane outputs are left open-circuit (see [Figure 21](#)).

All PCA8576D connected in cascade are correctly synchronized by the $\overline{\text{SYNC}}$ signal. This synchronization is guaranteed after the power-on reset. The only time that $\overline{\text{SYNC}}$ is likely to be needed is if synchronization is lost accidentally, for example, by noise in adverse electrical environments, or if the LCD multiplex drive mode is changed in an application using several cascaded PCA8576D, as the drive mode cannot be changed on all of the cascaded devices simultaneously. $\overline{\text{SYNC}}$ can be either an input or an output signal; a $\overline{\text{SYNC}}$ output is implemented as an open-drain driver with an internal pull-up resistor. The PCA8576D asserts $\overline{\text{SYNC}}$ at the start of its last active backplane signal and monitors the $\overline{\text{SYNC}}$ line at all other times. If cascade synchronization is lost, it is restored by the first PCA8576D to assert $\overline{\text{SYNC}}$. The timing relationship between the backplane waveforms and the $\overline{\text{SYNC}}$ signal for each LCD drive mode is shown in [Figure 22](#).

The contact resistance between the SYNC on each cascaded device must be controlled. If the resistance is too high, the device is not able to synchronize properly; this is particularly applicable to chip-on-glass applications. The maximum SYNC contact resistance allowed for the number of devices in cascade is given in Table 20.

Table 20. SYNC contact resistance

Number of devices	Maximum contact resistance
2	6 kΩ
3 to 5	2.2 kΩ
6 to 10	1.2 kΩ
10 to 16	700 Ω

The PCA8576D can be cascaded with the PCA8534A. This allows optimal drive selection for a given number of pixels to display. Figure 19 and Figure 20 show the timing of the synchronization signals.

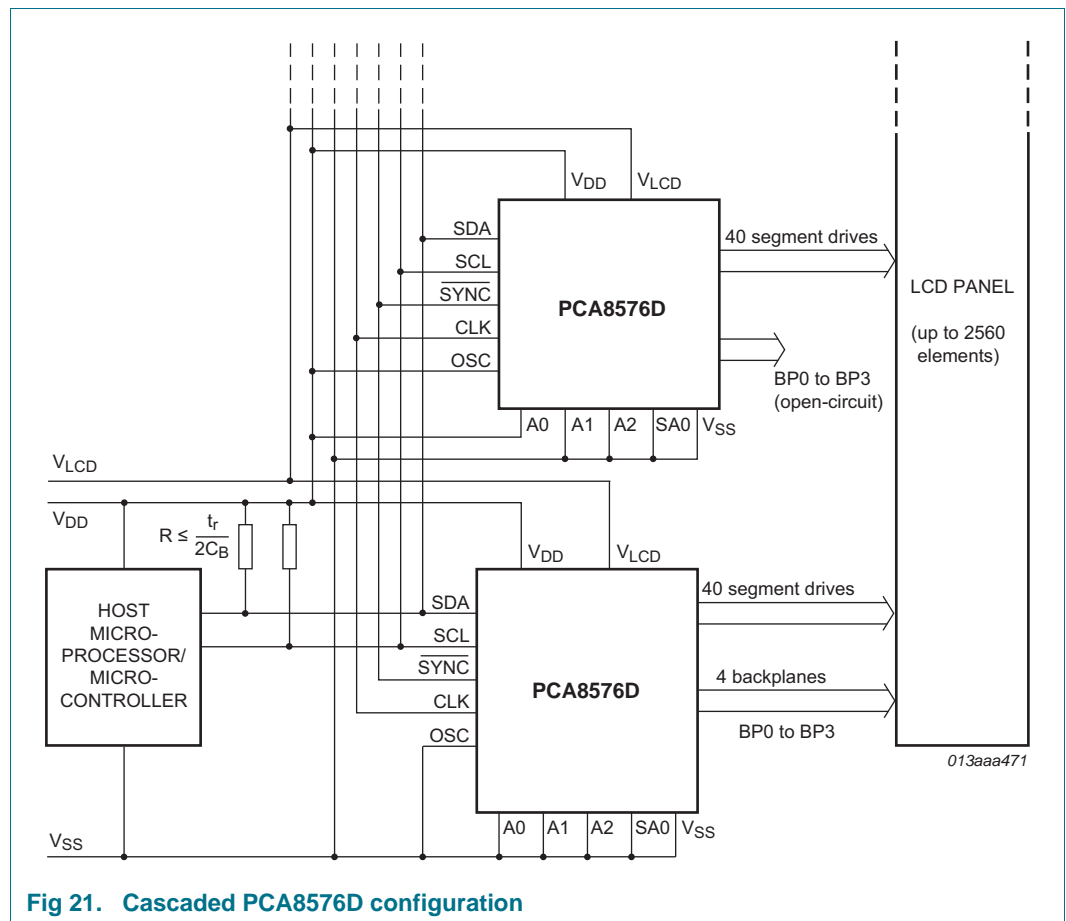
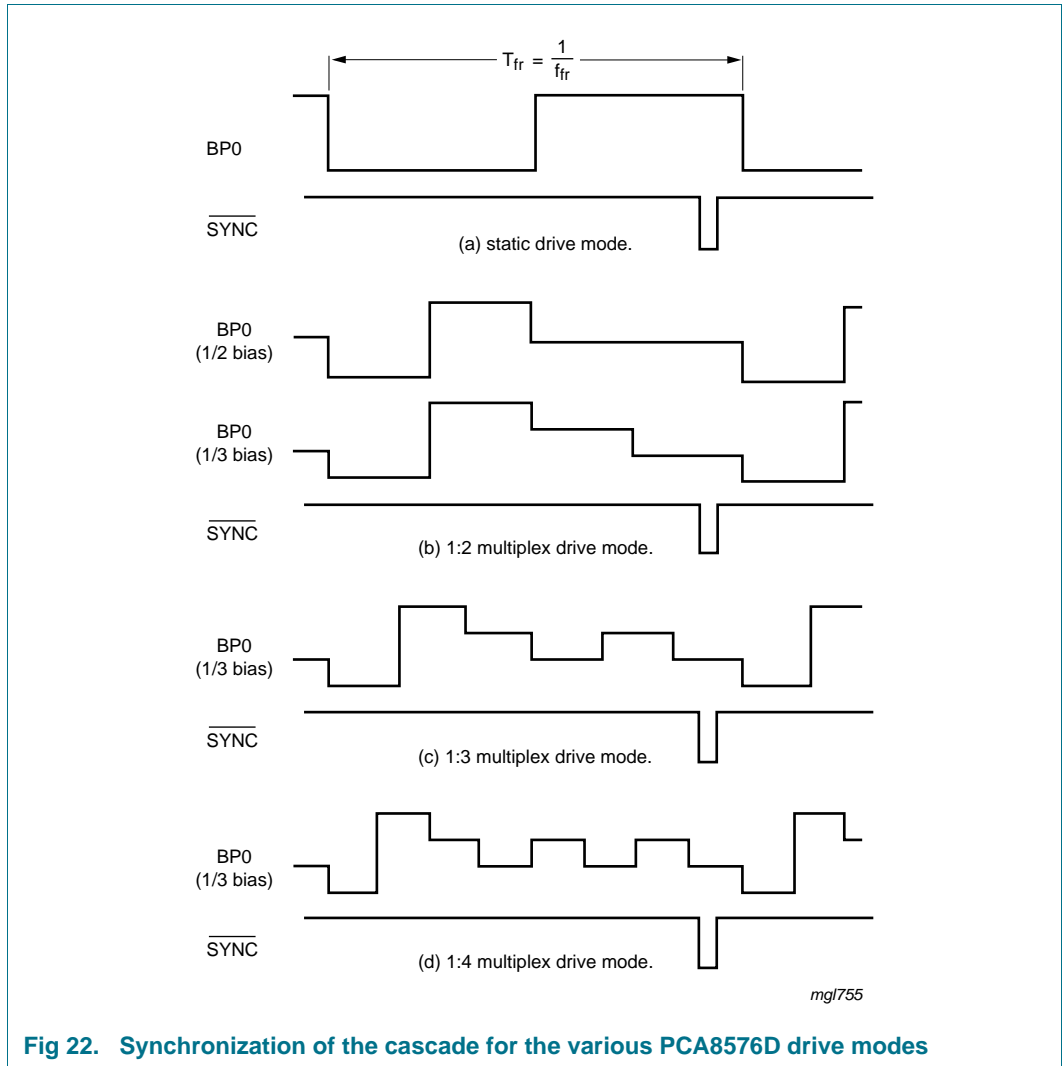

Fig 21. Cascaded PCA8576D configuration



12.2 RAM writing in 1:3 multiplex drive mode

In 1:3 multiplex drive mode, the RAM is written as shown in [Table 21](#) (see [Figure 11](#) as well).

Table 21. Standard RAM filling in 1:3 multiplex drive mode

Assumption: BP2/S2, BP2/S5, BP2/S8 etc. are not connected to any elements on the display.

Display RAM bits (rows)/backplane outputs (BPn)	Display RAM addresses (columns)/segment outputs (Sn)										
	0	1	2	3	4	5	6	7	8	9	:
0	a7	a4	a1	b7	b4	b1	c7	c4	c1	d7	:
1	a6	a3	a0	b6	b3	b0	c6	c3	c0	d6	:
2	a5	a2	-	b5	b2	-	c5	c2	-	d5	:
3	-	-	-	-	-	-	-	-	-	-	:

If the bit at position BP2/S2 would be written by a second byte transmitted, then the mapping of the segment bits would change as illustrated in [Table 22](#).

Table 22. Continuous RAM filling by rewriting in 1:3 multiplex drive mode

Assumption: BP2/S2, BP2/S5, BP2/S8 etc. are connected to elements on the display.

Display RAM bits (rows)/ backplane outputs (BPn)	Display RAM addresses (columns)/segment outputs (Sn)										
	0	1	2	3	4	5	6	7	8	9	:
0	a7	a4	a1/b7	b4	b1/c7	c4	c1/d7	d4	d1/e7	e4	:
1	a6	a3	a0/b6	b3	b0/c6	c3	c0/d6	d3	d0/e6	e3	:
2	a5	a2	b5	b2	c5	c2	d5	d2	e5	e2	:
3	-	-	-	-	-	-	-	-	-	-	:

In the case described in [Table 22](#) the RAM has to be written entirely and BP2/S2, BP2/S5, BP2/S8 etc. have to be connected to elements on the display. This can be achieved by a combination of writing and rewriting the RAM like follows:

- In the first write to the RAM, bits a7 to a0 are written.
- In the second write, bits b7 to b0 are written, overwriting bits a1 and a0 with bits b7 and b6.
- In the third write, bits c7 to c0 are written, overwriting bits b1 and b0 with bits c7 and c6.

Depending on the method of writing to the RAM (standard or continuous filling by rewriting), some elements remain unused or can be used, but it has to be considered in the module layout process as well as in the driver software design.

13. Test information

13.1 Quality information

This product has been qualified in accordance with the Automotive Electronics Council (AEC) standard Q100 - *Failure mechanism based stress test qualification for integrated circuits*, and is suitable for use in automotive applications.

14. Bare die outline

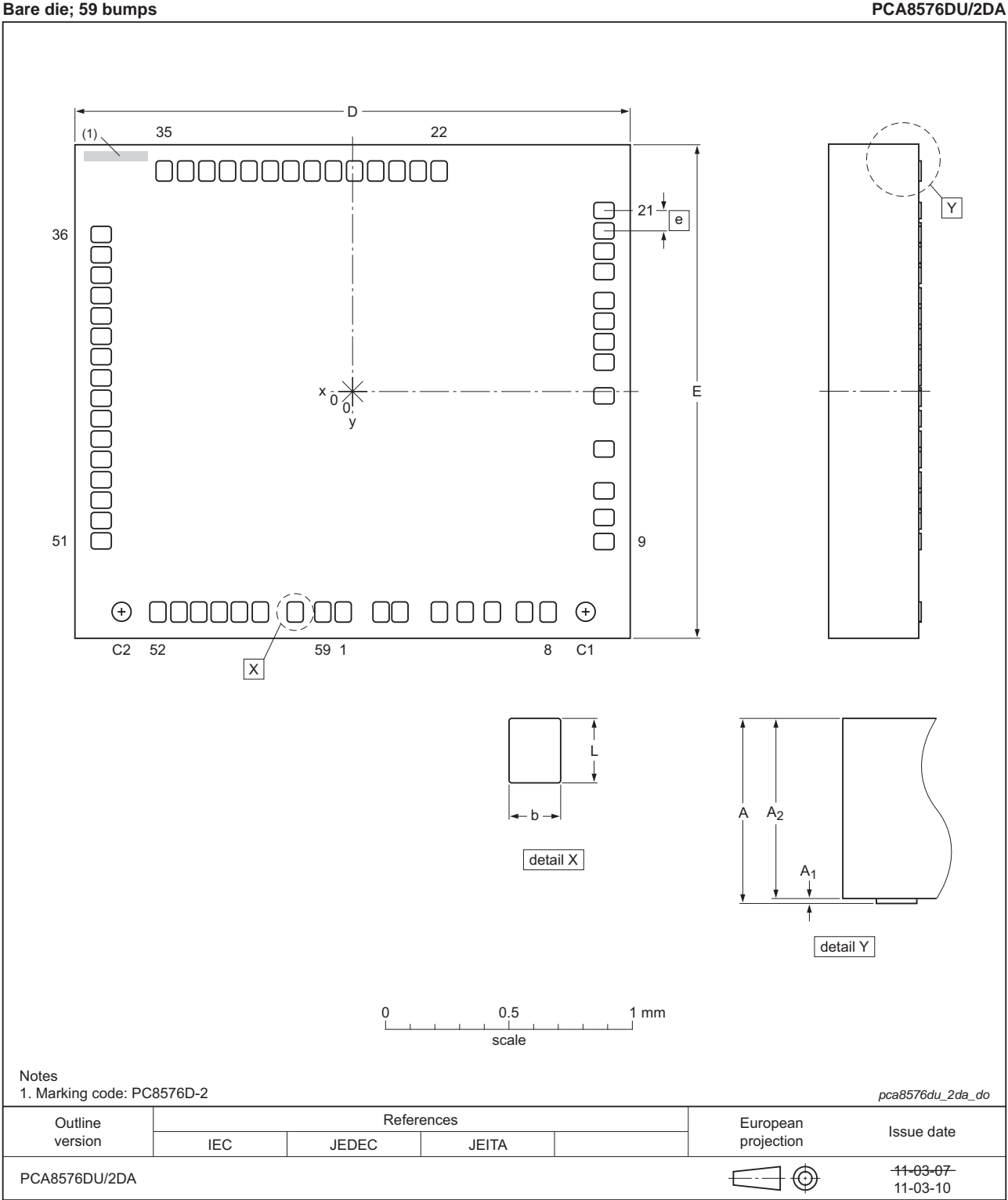

Fig 23. Bare die outline PCA8576DU/2DA/2 (for dimensions see Table 23)

Table 23. Dimensions of PCA8576DU

Original dimensions are in mm.

Unit (mm)	A	A ₁	A ₂	b	D	E	e ^[1]	L
max	-	-	-	-	-	-	-	-
nom	0.40	0.015	0.381	0.052	2.2	2.0	-	0.077
min	-	-	-	-	-	-	0.072	-

[1] Dimension not drawn to scale.

Table 24. Bump location for PCA8576DU

All x/y coordinates represent the position of the center of each bump with respect to the center (x/y = 0) of the chip (see [Figure 2](#) and [Figure 23](#)).

Symbol	Bump	X (μm)	Y (μm)	Description
SDA	1	-34.38	-876.6	I ² C-bus serial data input/output
SCL	2	109.53	-876.6	I ² C-bus serial clock input
SCL	3	181.53	-876.6	
SYNC	4	365.58	-876.6	cascade synchronization input/output
CLK	5	469.08	-876.6	external clock input/output
V _{DD}	6	577.08	-876.6	supply voltage
OSC	7	740.88	-876.6	internal oscillator enable input
A0	8	835.83	-876.6	subaddress inputs
A1	9	1005.48	-630.9	
A2	10	1005.48	-513.9	
SA0	11	1005.48	-396.9	I ² C-bus address input; bit 0
V _{SS}	12	1005.48	-221.4	ground supply voltage
V _{LCD}	13	1005.48	10.71	LCD supply voltage
BP0	14	1005.48	156.51	LCD backplane outputs
BP2	15	1005.48	232.74	
BP1	16	1005.48	308.97	
BP3	17	1005.48	385.2	
S0	18	1005.48	493.2	LCD segment outputs
S1	19	1005.48	565.2	
S2	20	1005.48	637.2	
S3	21	1005.48	709.2	
S4	22	347.22	876.6	LCD segment outputs
S5	23	263.97	876.6	
S6	24	180.72	876.6	
S7	25	97.47	876.6	
S8	26	14.22	876.6	
S9	27	-69.03	876.6	
S10	28	-152.28	876.6	
S11	29	-235.53	876.6	
S12	30	-318.78	876.6	

Table 24. Bump location for PCA8576DU ...continued

All x/y coordinates represent the position of the center of each bump with respect to the center (x/y = 0) of the chip (see [Figure 2](#) and [Figure 23](#)).

Symbol	Bump	X (μm)	Y (μm)	Description
S13	31	-402.03	876.6	
S14	32	-485.28	876.6	
S15	33	-568.53	876.6	
S16	34	-651.78	876.6	
S17	35	-735.03	876.6	
S18	36	-1005.5	625.59	
S19	37	-1005.5	541.62	
S20	38	-1005.5	458.19	
S21	39	-1005.5	374.76	
S22	40	-1005.5	291.33	
S23	41	-1005.5	207.9	
S24	42	-1005.5	124.47	
S25	43	-1005.5	41.04	
S26	44	-1005.5	-42.39	
S27	45	-1005.5	-125.8	
S28	46	-1005.5	-209.3	
S29	47	-1005.5	-292.7	
S30	48	-1005.5	-376.1	
S31	49	-1005.5	-459.5	
S32	50	-1005.5	-543	
S33	51	-1005.5	-625.6	
S34	52	-735.03	-876.6	
S35	53	-663.03	-876.6	
S36	54	-591.03	-876.6	
S37	55	-519.03	-876.6	
S38	56	-447.03	-876.6	
S39	57	-375.03	-876.6	LCD segment outputs
SDA	58	-196.38	-876.6	I ² C-bus serial data input/output
SDA	59	-106.38	-876.6	

Table 25. Alignment marks

All x/y coordinates represent the position of the center of each alignment mark with respect to the center (x/y = 0) of the chip (see [Figure 2](#) and [Figure 23](#)).

Symbol	X (μm)	Y (μm)
C1	930.42	-870.3
C2	-829.98	-870.3

15. Handling information

All input and output pins are protected against ElectroStatic Discharge (ESD) under normal handling. When handling Metal-Oxide Semiconductor (MOS) devices ensure that all normal precautions are taken as described in *JESD625-A*, *IEC 61340-5* or equivalent standards.

16. Packing information

16.1 Tray information

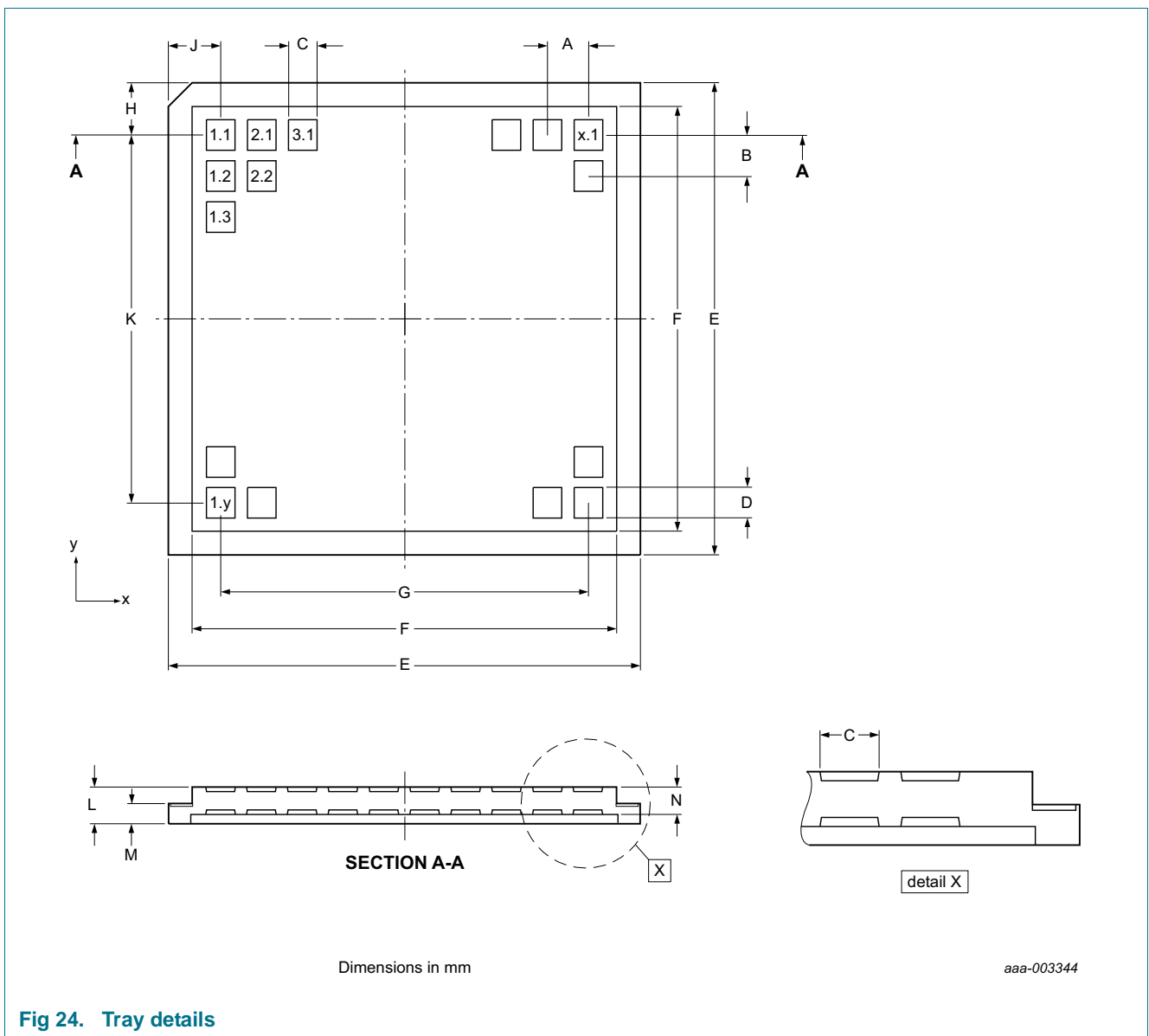

Fig 24. Tray details

Table 26. Description of tray details

Tray details are shown in [Figure 24](#).

Tray details													
Dimensions													
A	B	C	D	E	F	G	H	J	K	L	M	N	Unit
3.6	3.6	2.36	2.11	50.8	45.72	39.6	5.6	5.6	39.6	3.96	2.18	2.49	mm
Number of pockets													
x direction							y direction						
12							12						

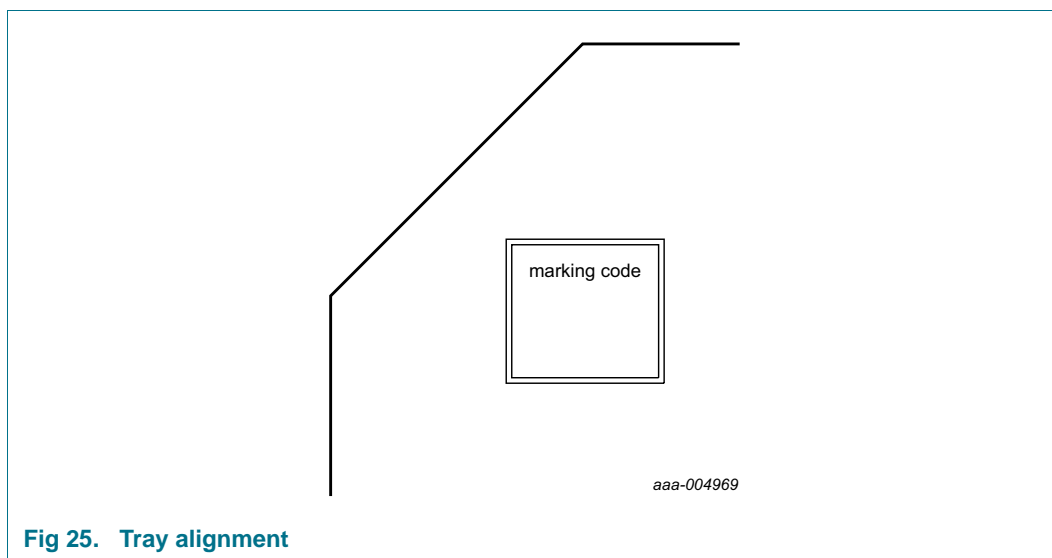

Fig 25. Tray alignment

17. Abbreviations

Table 27. Abbreviations

Acronym	Description
CMOS	Complementary Metal-Oxide Semiconductor
HBM	Human Body Model
ITO	Indium Tin Oxide
LCD	Liquid Crystal Display
LSB	Least Significant Bit
MM	Machine Model
MSB	Most Significant Bit
PCB	Printed Circuit Board
RAM	Random Access Memory
RMS	Root Mean Square
SCL	Serial CLock line
SDA	Serial DAta line

18. References

- [1] **AN10170** — Design guidelines for COG modules with NXP monochrome LCD drivers
- [2] **AN10706** — Handling bare die
- [3] **IEC 60134** — Rating systems for electronic tubes and valves and analogous semiconductor devices
- [4] **IEC 61340-5** — Protection of electronic devices from electrostatic phenomena
- [5] **IPC/JEDEC J-STD-020D** — Moisture/Reflow Sensitivity Classification for Nonhermetic Solid State Surface Mount Devices
- [6] **JESD22-A114** — Electrostatic Discharge (ESD) Sensitivity Testing Human Body Model (HBM)
- [7] **JESD22-A115** — Electrostatic Discharge (ESD) Sensitivity Testing Machine Model (MM)
- [8] **JESD78** — IC Latch-Up Test
- [9] **JESD625-A** — Requirements for Handling Electrostatic-Discharge-Sensitive (ESDS) Devices
- [10] **UM10204** — I²C-bus specification and user manual
- [11] **UM10569** — Store and transport requirements

19. Revision history

Table 28. Revision history

Document ID	Release date	Data sheet status	Change notice	Supersedes
PCA8576D v.2	20130606	Product data sheet	-	PCA8576D v.1
Modifications:	<ul style="list-style-type: none"> • Added improved I_{DD} and I_{DD(LCD)} values (Table 17) • Improved description of bit E • Changed tray information (Section 16.1) 			
PCA8576D v.1	20110404	Product data sheet	-	-

20. Legal information

20.1 Data sheet status

Document status ^{[1][2]}	Product status ^[3]	Definition
Objective [short] data sheet	Development	This document contains data from the objective specification for product development.
Preliminary [short] data sheet	Qualification	This document contains data from the preliminary specification.
Product [short] data sheet	Production	This document contains the product specification.

[1] Please consult the most recently issued document before initiating or completing a design.

[2] The term 'short data sheet' is explained in section "Definitions".

[3] The product status of device(s) described in this document may have changed since this document was published and may differ in case of multiple devices. The latest product status information is available on the Internet at URL <http://www.nxp.com>.

20.2 Definitions

Draft — The document is a draft version only. The content is still under internal review and subject to formal approval, which may result in modifications or additions. NXP Semiconductors does not give any representations or warranties as to the accuracy or completeness of information included herein and shall have no liability for the consequences of use of such information.

Short data sheet — A short data sheet is an extract from a full data sheet with the same product type number(s) and title. A short data sheet is intended for quick reference only and should not be relied upon to contain detailed and full information. For detailed and full information see the relevant full data sheet, which is available on request via the local NXP Semiconductors sales office. In case of any inconsistency or conflict with the short data sheet, the full data sheet shall prevail.

Product specification — The information and data provided in a Product data sheet shall define the specification of the product as agreed between NXP Semiconductors and its customer, unless NXP Semiconductors and customer have explicitly agreed otherwise in writing. In no event however, shall an agreement be valid in which the NXP Semiconductors product is deemed to offer functions and qualities beyond those described in the Product data sheet.

20.3 Disclaimers

Limited warranty and liability — Information in this document is believed to be accurate and reliable. However, NXP Semiconductors does not give any representations or warranties, expressed or implied, as to the accuracy or completeness of such information and shall have no liability for the consequences of use of such information. NXP Semiconductors takes no responsibility for the content in this document if provided by an information source outside of NXP Semiconductors.

In no event shall NXP Semiconductors be liable for any indirect, incidental, punitive, special or consequential damages (including - without limitation - lost profits, lost savings, business interruption, costs related to the removal or replacement of any products or rework charges) whether or not such damages are based on tort (including negligence), warranty, breach of contract or any other legal theory.

Notwithstanding any damages that customer might incur for any reason whatsoever, NXP Semiconductors' aggregate and cumulative liability towards customer for the products described herein shall be limited in accordance with the *Terms and conditions of commercial sale* of NXP Semiconductors.

Right to make changes — NXP Semiconductors reserves the right to make changes to information published in this document, including without limitation specifications and product descriptions, at any time and without notice. This document supersedes and replaces all information supplied prior to the publication hereof.

Suitability for use in automotive applications — This NXP Semiconductors product has been qualified for use in automotive applications. Unless otherwise agreed in writing, the product is not designed, authorized or warranted to be suitable for use in life support, life-critical or safety-critical systems or equipment, nor in applications where failure or malfunction of an NXP Semiconductors product can reasonably be expected to result in personal injury, death or severe property or environmental damage. NXP Semiconductors and its suppliers accept no liability for inclusion and/or use of NXP Semiconductors products in such equipment or applications and therefore such inclusion and/or use is at the customer's own risk.

Applications — Applications that are described herein for any of these products are for illustrative purposes only. NXP Semiconductors makes no representation or warranty that such applications will be suitable for the specified use without further testing or modification.

Customers are responsible for the design and operation of their applications and products using NXP Semiconductors products, and NXP Semiconductors accepts no liability for any assistance with applications or customer product design. It is customer's sole responsibility to determine whether the NXP Semiconductors product is suitable and fit for the customer's applications and products planned, as well as for the planned application and use of customer's third party customer(s). Customers should provide appropriate design and operating safeguards to minimize the risks associated with their applications and products.

NXP Semiconductors does not accept any liability related to any default, damage, costs or problem which is based on any weakness or default in the customer's applications or products, or the application or use by customer's third party customer(s). Customer is responsible for doing all necessary testing for the customer's applications and products using NXP Semiconductors products in order to avoid a default of the applications and the products or of the application or use by customer's third party customer(s). NXP does not accept any liability in this respect.

Limiting values — Stress above one or more limiting values (as defined in the Absolute Maximum Ratings System of IEC 60134) will cause permanent damage to the device. Limiting values are stress ratings only and (proper) operation of the device at these or any other conditions above those given in the Recommended operating conditions section (if present) or the Characteristics sections of this document is not warranted. Constant or repeated exposure to limiting values will permanently and irreversibly affect the quality and reliability of the device.

Terms and conditions of commercial sale — NXP Semiconductors products are sold subject to the general terms and conditions of commercial sale, as published at <http://www.nxp.com/profile/terms>, unless otherwise agreed in a valid written individual agreement. In case an individual agreement is concluded only the terms and conditions of the respective agreement shall apply. NXP Semiconductors hereby expressly objects to applying the customer's general terms and conditions with regard to the purchase of NXP Semiconductors products by customer.

No offer to sell or license — Nothing in this document may be interpreted or construed as an offer to sell products that is open for acceptance or the grant, conveyance or implication of any license under any copyrights, patents or other industrial or intellectual property rights.

Export control — This document as well as the item(s) described herein may be subject to export control regulations. Export might require a prior authorization from competent authorities.

Bare die — All die are tested on compliance with their related technical specifications as stated in this data sheet up to the point of wafer sawing and are handled in accordance with the NXP Semiconductors storage and transportation conditions. If there are data sheet limits not guaranteed, these will be separately indicated in the data sheet. There are no post-packing tests performed on individual die or wafers.

NXP Semiconductors has no control of third party procedures in the sawing, handling, packing or assembly of the die. Accordingly, NXP Semiconductors assumes no liability for device functionality or performance of the die or systems after third party sawing, handling, packing or assembly of the die. It is the responsibility of the customer to test and qualify their application in which the die is used.

All die sales are conditioned upon and subject to the customer entering into a written die sale agreement with NXP Semiconductors through its legal department.

20.4 Trademarks

Notice: All referenced brands, product names, service names and trademarks are the property of their respective owners.

I²C-bus — logo is a trademark of NXP B.V.

21. Contact information

For more information, please visit: <http://www.nxp.com>

For sales office addresses, please send an email to: salesaddresses@nxp.com

22. Tables

Table 1.	Ordering information	2
Table 2.	Ordering options	2
Table 3.	Marking codes	2
Table 4.	Pin description	4
Table 5.	Selection of possible display configurations	5
Table 6.	Discrimination ratios	6
Table 7.	Blinking frequencies ^[1]	19
Table 8.	I ² C slave address byte	21
Table 9.	Definition of PCA8576D commands	23
Table 10.	C bit description	23
Table 11.	Mode-set command bit description	23
Table 12.	Load-data-pointer command bit description	24
Table 13.	Device-select command bit description	24
Table 14.	Bank-select command bit description	24
Table 15.	Blink-select command bit description	25
Table 16.	Limiting values	27
Table 17.	Static characteristics	28
Table 18.	Dynamic characteristics	29
Table 19.	Addressing cascaded PCA8576D	31
Table 20.	SYNC contact resistance	32
Table 21.	Standard RAM filling in 1:3 multiplex drive mode	33
Table 22.	Continuous RAM filling by rewriting in 1:3 multiplex drive mode	34
Table 23.	Dimensions of PCA8576DU	36
Table 24.	Bump location for PCA8576DU	36
Table 25.	Alignment marks	37
Table 26.	Description of tray details	39
Table 27.	Abbreviations	39
Table 28.	Revision history	40

23. Figures

Fig 1.	Block diagram of PCA8576D	2
Fig 2.	Pinning diagram for PCA8576DU (bare die)	3
Fig 3.	Typical system configuration	5
Fig 4.	Electro-optical characteristic: relative transmission curve of the liquid	8
Fig 5.	Static drive mode waveforms	9
Fig 6.	Waveforms for the 1:2 multiplex drive mode with $\frac{1}{2}$ bias	10
Fig 7.	Waveforms for the 1:2 multiplex drive mode with $\frac{1}{3}$ bias	11
Fig 8.	Waveforms for the 1:3 multiplex drive mode with $\frac{1}{3}$ bias	12
Fig 9.	Waveforms for the 1:4 multiplex drive mode with $\frac{1}{3}$ bias	13
Fig 10.	Display RAM bit map	15
Fig 11.	Relationship between LCD layout, drive mode, display RAM filling order and display data transmitted over the I ² C-bus	16
Fig 12.	Bit transfer	19
Fig 13.	Definition of START and STOP conditions.	20
Fig 14.	System configuration	20
Fig 15.	Acknowledgement of the I ² C-bus	21
Fig 16.	I ² C-bus protocol	22
Fig 17.	Format of command byte	22
Fig 18.	Device protection circuits	26
Fig 19.	Driver timing waveforms	30
Fig 20.	I ² C-bus timing waveforms	30
Fig 21.	Cascaded PCA8576D configuration	32
Fig 22.	Synchronization of the cascade for the various PCA8576D drive modes	33
Fig 23.	Bare die outline PCA8576DU/2DA/2 (for dimensions see Table 23)	35
Fig 24.	Tray details	38
Fig 25.	Tray alignment	39

24. Contents

1	General description	1	12	Application information	31
2	Features and benefits	1	12.1	Cascaded operation	31
3	Ordering information	2	12.2	RAM writing in 1:3 multiplex drive mode	33
3.1	Ordering options	2	13	Test information	34
4	Marking	2	13.1	Quality information	34
5	Block diagram	2	14	Bare die outline	35
6	Pinning information	3	15	Handling information	38
6.1	Pinning	3	16	Packing information	38
6.2	Pin description	4	16.1	Tray information	38
7	Functional description	5	17	Abbreviations	39
7.1	Power-on reset	6	18	References	40
7.2	LCD bias generator	6	19	Revision history	40
7.3	LCD voltage selector	6	20	Legal information	41
7.3.1	Electro-optical performance	7	20.1	Data sheet status	41
7.4	LCD drive mode waveforms	9	20.2	Definitions	41
7.4.1	Static drive mode	9	20.3	Disclaimers	41
7.4.2	1:2 Multiplex drive mode	10	20.4	Trademarks	42
7.4.3	1:3 Multiplex drive mode	12	21	Contact information	42
7.4.4	1:4 Multiplex drive mode	13	22	Tables	43
7.5	Oscillator	14	23	Figures	44
7.5.1	Internal clock	14	24	Contents	45
7.5.2	External clock	14			
7.6	Timing	14			
7.7	Display register	14			
7.8	Segment outputs	14			
7.9	Backplane outputs	14			
7.10	Display RAM	15			
7.11	Data pointer	17			
7.12	Subaddress counter	17			
7.13	Output bank selector	18			
7.14	Input bank selector	18			
7.15	Blinking	18			
7.16	Characteristics of the I ² C-bus	19			
7.16.1	Bit transfer	19			
7.16.2	START and STOP conditions	20			
7.16.3	System configuration	20			
7.16.4	Acknowledge	20			
7.16.5	I ² C-bus controller	21			
7.16.6	Input filters	21			
7.16.7	I ² C-bus protocol	21			
7.17	Command decoder	23			
7.18	Display controller	25			
8	Internal circuitry	26			
9	Limiting values	27			
10	Static characteristics	28			
11	Dynamic characteristics	29			

Please be aware that important notices concerning this document and the product(s) described herein, have been included in section 'Legal information'.

© NXP B.V. 2013.

All rights reserved.

For more information, please visit: <http://www.nxp.com>

For sales office addresses, please send an email to: salesaddresses@nxp.com

Date of release: 6 June 2013

Document identifier: PCA8576D