

# Multi- function LCD Segment Drivers

BU97501KV MAX 204 Segment (51SEGx4COM)

## Features

- Key input function for up to 30 keys (A key scan is performed only when a key is pressed.)
- Either 1/4 or 1/3 Duty can be selected  
1/4 Duty drive : Up to 204 segments  
1/3 Duty drive : Up to 156 segments
- Integrated RAM for display data (DDRAM)
- Segment/GPO (Max 4port) output mode selectable
- Support standby mode
- Integrated Power-on Reset circuit
- Integrated Oscillator circuit
- No external component
- Low power consumption design

## Applications

- Telephone
- FAX
- Portable equipment (POS, ECR, PDA etc.)
- DSC
- DVC
- Car audio
- Home electrical appliance
- Meter equipment

## Key Specifications

- Supply Voltage Range: 2.7V to 6.0V
- LCD drive power supply Range: 4.5V to 6.0V
- Operating Temperature Range: -40°C to +85°C
- Max Segments: 204 Segments
- Display Duty: 1/3, 1/4 selectable
- Bias: 1/2, 1/3 selectable
- Interface: 3wire serial interface

## Package

VQFP64

W (Typ) x D (Typ) x H (Max)

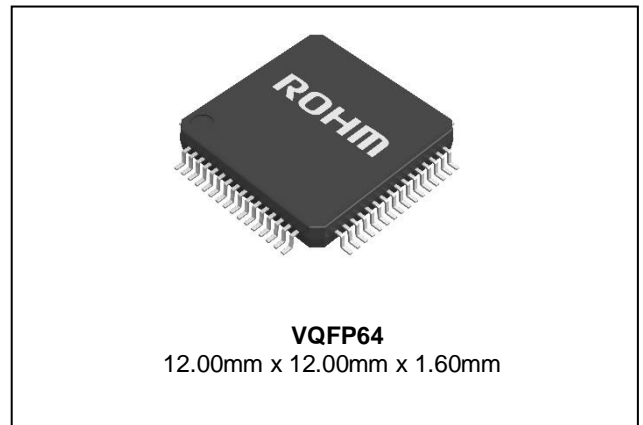

## Typical Application Circuit

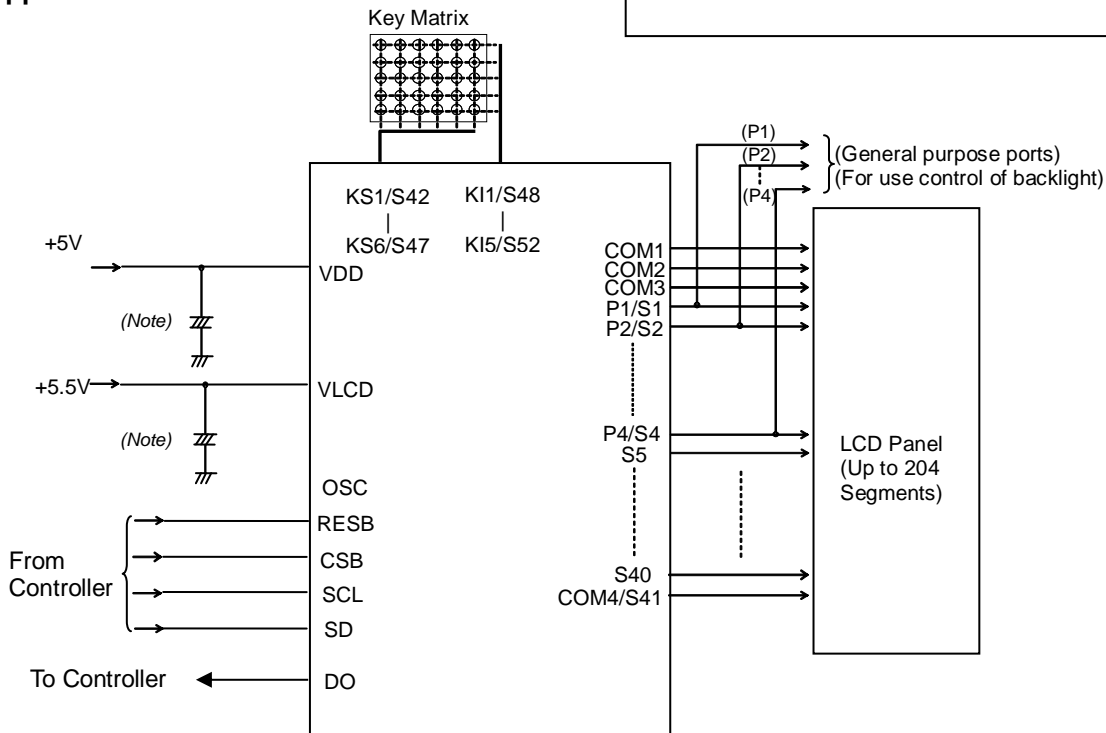

(Note) Insert capacitors between VDD/VLCD and VSS C≥0.1μF.

**Figure 1. Typical Application Circuit**

○Product structure : Silicon integrated circuit ○This product has no designed protection against radioactive rays.

Block Diagram / Pin Configuration / Pin Description

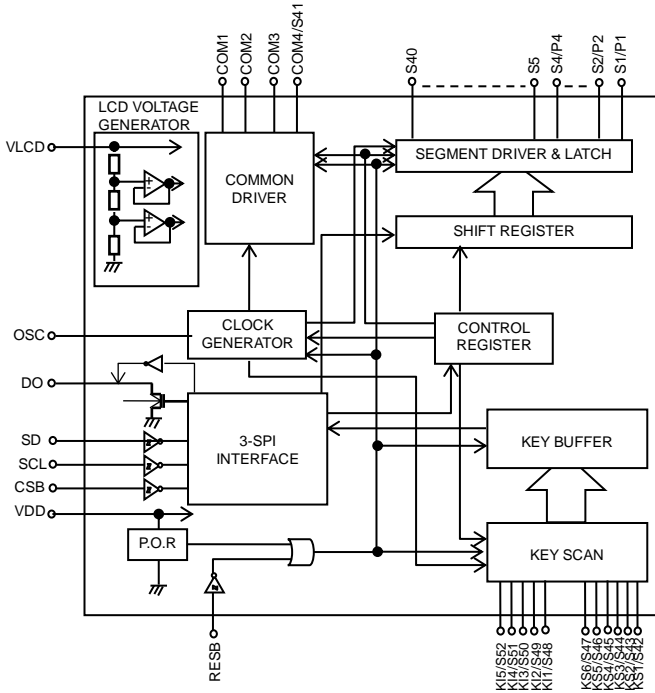

Figure 2. Block Diagram

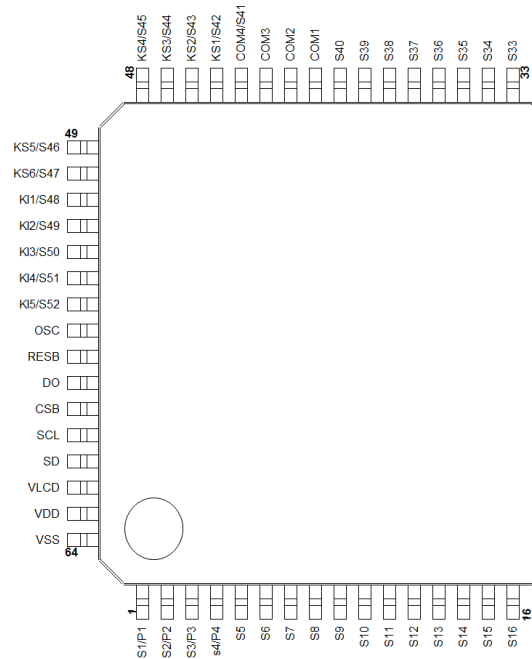

Figure 3. Pin Configuration (TOP VIEW)

Terminal	Terminal No.	I/O	Handling When Unused	Functions
CSB	59	I	VDD	Chip select : "L" active
SCL	60	I	VSS	Serial data transfer clock
SD	61	I	VSS	Input serial data
VDD	63	-	-	Power Supply for the logic
OSC	56	I	OPEN/VSS	External Clock Input: Fix to low or open when the internal clock mode setting.
DO	58	O	OPEN	Output data
RESB	57	I	VDD	Reset Input: RESB="L" : Display is disabled. RESB="H" : Display is controllable. However, serial data cannot be transferred when RESB is "L".
VSS	64	-	-	Power supply pin. Must be connected to Ground.
VLCD	62	-	-	Power Supply for the LCD driver
COM1 to COM3	41 to 43	O	OPEN	COMMON output for LCD driver
COM4/S41	44	O	OPEN	COMMON / SEGMENT output for LCD driver. Assigned as SEGMENT output in 1/3Duty mode.
S1/P1 to S4/P4	1 to 4	O	OPEN	SEGMENT output for LCD driving / General Purpose Output S1/P1 to S4/P4 pins can also be used as General Purpose Outputs when set up by the control data.
S5 to S40	5 to 40	O	OPEN	SEGMENT output for LCD driver
KS1/S42 to KS6/S47	45 to 50	O	OPEN	Key scan outputs Although normal key scan timing lines require diodes to be inserted in the timing lines to prevent shorts, since these outputs are unbalanced CMOS transistor outputs, these outputs will not be damaged by shorting when these outputs are used to form a key matrix. The KS1/S42 to KS6/S47 pins can be used as segment outputs when specified by the control data.
KI1/S48 to KI5/S52	51 to 55	I O	VSS OPEN	Key scan inputs These pins have built-in pull-down resistors. The KI1/S48 to KI5/S52 pins can be used as segment outputs when specified by the control data.

Table 1. Pin Description

**Absolute Maximum Ratings (VSS=0.0V)**

Parameters	Symbol	Ratings	Unit	Remarks
Power Supply voltage 1	VDD	-0.5 to +7.0	V	Power supply
Power Supply voltage 2	VLCD	-0.5 to +7.0	V	LCD drive voltage
Power Dissipation	Pd	1.00 <sup>(Note 1)</sup>	W	
Input voltage range	V <sub>IN</sub>	-0.5 to VDD+0.5	V	
Storage temperature range	Tstg	-55 to +125	°C	

(Note 1) When operated higher than Ta=25°C, subtract 10mW per degree. (Using ROHM standard board)

(Board size: 70mm×70mm×1.6mm material: FR4 board copper foil: land pattern only)

**Caution1:** Operating the IC over the absolute maximum ratings may damage the IC. The damage can either be a short circuit between pins or an open circuit between pins and the internal circuitry. Therefore, it is important to consider circuit protection measures, such as adding a fuse, in case the IC is operated over the absolute maximum ratings.

**Caution2:** Should by any chance the maximum junction temperature rating be exceeded the rise in temperature of the chip may result in deterioration of the properties of the chip. In case of exceeding this absolute maximum rating, design a PCB with power dissipation taken into consideration by increasing board size and copper area so as not to exceed the maximum junction temperature rating.

**Recommended Operating Conditions (VSS=0.0V)**

Parameters	Symbol	Ratings			Unit	Remarks
		Min	Typ	Max		
Operating temperature	Topr	-40	-	+85	°C	
Power Supply voltage 1	VDD	2.7	-	6.0	V	Power supply
Power Supply voltage 2	VLCD	4.5	-	6.0	V	LCD driver voltage

(Note 2) The power supply condition shall be met VLCD ≥ VDD.

**Electrical Characteristics**

(Unless otherwise specified, Ta=-40°C to +85°C, VDD=2.7 to 6.0V, VLCD=4.5 to 6.0V, VSS=0.0V)

Parameters	Symbol	Limits			Unit	Conditions
		Min	Typ	Max		
"H" Input Voltage	V <sub>IH</sub>	0.7VDD	-	VDD	V	SD, SCL, CSB, RESB, OSC
"L" Input Voltage	V <sub>IL</sub>	VSS	-	0.3VDD	V	SD, SCL, CSB, RESB, OSC
"H" Input Current	I <sub>IH</sub>	-	-	5.0	μA	SD, SCL, CSB, RESB, OSC, V <sub>I</sub> =5.5V
"L" Input Current	I <sub>IL</sub>	-5.0	-	-	μA	SD, SCL, CSB, RESB, OSC, V <sub>I</sub> =0.0V
Input Floating Voltage	V <sub>IF</sub>	-	-	0.05VDD	V	KI1 to KI5
Pull-down Resistance	R <sub>PD</sub>	50	100	250	kΩ	KI1 to KI5, VLCD=5.0V
Output Off Leakage Current	I <sub>OFFH</sub>	-	-	6.0	μA	DO, V <sub>O</sub> =5.5V
"H" Level Output Voltage	V <sub>OH1</sub>	VLCD-1.0	-	-	V	P1 to P4, I <sub>O</sub> =-1mA
	V <sub>OH2</sub>	VLCD-1.0	-	-		S1 to S52, I <sub>O</sub> =-20μA
	V <sub>OH3</sub>	VLCD-1.0	-	-		COM1 to COM4, I <sub>O</sub> =-100μA
	V <sub>OH4</sub>	VLCD-1.0	-	-		KS1 to KS6, I <sub>O</sub> =-500μA
"L" Level Output Voltage	V <sub>OL1</sub>	-	-	1.0	V	P1 to P4, I <sub>O</sub> =1mA
	V <sub>OL2</sub>	-	-	1.0		S1 to S52, I <sub>O</sub> =20μA
	V <sub>OL3</sub>	-	-	1.0		COM1 to COM4, I <sub>O</sub> =100μA
	V <sub>OL4</sub>	-	-	1.0		KS1 to KS6, I <sub>O</sub> =25μA
	V <sub>OL5</sub>	-	-	0.5		DO, I <sub>O</sub> =1mA
LCD Bias Voltage	V <sub>MID1</sub>	1/2VLCD -1.0	-	1/2VLCD +1.0	V	S1 to S52 1/2 Bias, I <sub>O</sub> =±20μA
	V <sub>MID2</sub>	1/2VLCD -1.0	-	1/2VLCD +1.0		COM1 to COM4 1/2 Bias, I <sub>O</sub> =±100μA
	V <sub>MID3</sub>	2/3VLCD -1.0	-	2/3VLCD +1.0		S1 to S52 1/3 Bias, I <sub>O</sub> =±20μA
	V <sub>MID4</sub>	1/3VLCD -1.0	-	1/3VLCD +1.0		S1 to S52 1/3 Bias, I <sub>O</sub> =±20μA
	V <sub>MID5</sub>	2/3VLCD -1.0	-	2/3VLCD +1.0		COM1 to COM4 1/3Bias, I <sub>O</sub> =±100μA
	V <sub>MID6</sub>	1/3VLCD -1.0	-	1/3VLCD +1.0		COM1 to COM4 1/3 Bias, I <sub>O</sub> =±100μA

Electrical Characteristics – continued

Parameters	Symbol	Limits			Unit	Conditions
		Min	Typ	Max		
Current Consumption	Ist <sub>VDD</sub>	-	1	5	μA	Input Pin ALL "L" Display off, Disable oscillator
	Ist <sub>VLCD</sub>	-	1	5		Input Pin ALL "L" Display off, Disable oscillator
	I <sub>VDD1</sub>	-	2	10		VDD=VLCD=5.0V, Output unloaded f <sub>FR</sub> =80Hz
	I <sub>VLCD1</sub>	-	40	95		VDD=VLCD=5.0V, Output unloaded 1/2 Bias, f <sub>FR</sub> =80Hz
	I <sub>VLCD2</sub>	-	65	140		VDD=VLCD=5.0V, Output unloaded 1/3 Bias, f <sub>FR</sub> =80Hz

Oscillation Characteristics (Ta=-40°C to +85°C, VDD=2.7 to 6.0V, VLCD=4.5V to 6.0V, VSS=0.0V)

Parameters	Symbol	Limits			Unit	Conditions
		Min	Typ	Max		
Frame Frequency1	f <sub>FR1</sub>	56	80	104	Hz	VLCD=4.5V to 6.0V, f <sub>FR</sub> = 80Hz setting
Frame Frequency2	f <sub>FR2</sub>	68	80	92	Hz	VLCD=5.0V, f <sub>FR</sub> = 80Hz setting
External Clock Frequency	f <sub>FR3</sub>	30	-	600	kHz	External clock mode (DRV CTRL1 setting : P2P1=11)
External Clock Rise Time	tr	-	-	80		
External Clock Fall Time	tf	-	-	80		
External Clock Duty	t <sub>DY</sub>	30	50	70		

Frame frequency is decided external frequency and dividing ratio of DRV CTRL1 setting.

[Reference Data]

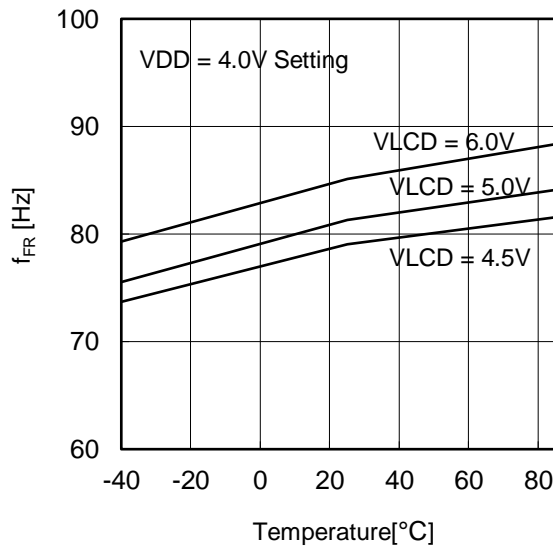

Figure 4. Frame Frequency Typical temperature characteristics

**Electrical Characteristics – continued**

MPU Interface Characteristics (Ta=-40 to +85°C, VDD=2.7V to 6.0V, VLCD=4.5 to 6.0V, VSS=0.0V)

Parameters	Symbol	Limits			Unit	Conditions
		MIN	TYP	MAX		
Input Rise Time	tr	-	-	80	ns	
Input Fall Time	tf	-	-	80	ns	
SCL Cycle Time	t <sub>SCYC</sub>	400	-	-	ns	
“H” SCL Pulse Width	t <sub>SHW</sub>	100	-	-	ns	
“L” SCL Pulse Width	t <sub>SLW</sub>	100	-	-	ns	
SD Setup Time	t <sub>SDS</sub>	20	-	-	ns	
SD Hold Time	t <sub>SDH</sub>	20	-	-	ns	
CSB Setup Time	t <sub>CSS</sub>	50	-	-	ns	
CSB Hold Time	t <sub>CSH</sub>	50	-	-	ns	
“H” CSB Pulse Width	t <sub>CHW</sub>	50	-	-	ns	
DO Output Delay Time	t <sub>DC</sub>	-	-	1.5	μs	DO R <sub>PU</sub> =4.7kΩ, C <sub>L</sub> =10pF (Note)
DO Rise Time	t <sub>DR</sub>	-	-	1.5	μs	DO R <sub>PU</sub> =4.7kΩ, C <sub>L</sub> =10pF (Note)

(Note) Since DO can be an open-drain output; these values depend on the resistance of the pull-up resistor RPU and the load capacitance CL.  
 RPU: 1kΩ≤RPU≤10kΩ is recommended.  
 CL: A parasitic capacitance to VSS in an application circuit. Any component is not necessary to be attached.

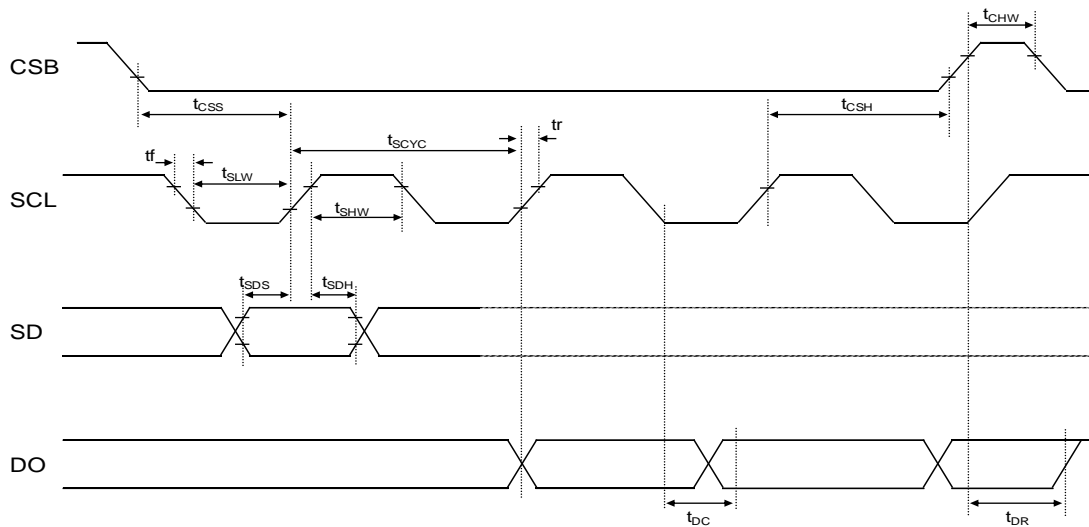
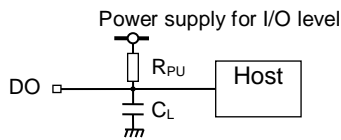

**Figure 5. 3-wire Serial Interface Timing**

I/O equivalent circuit

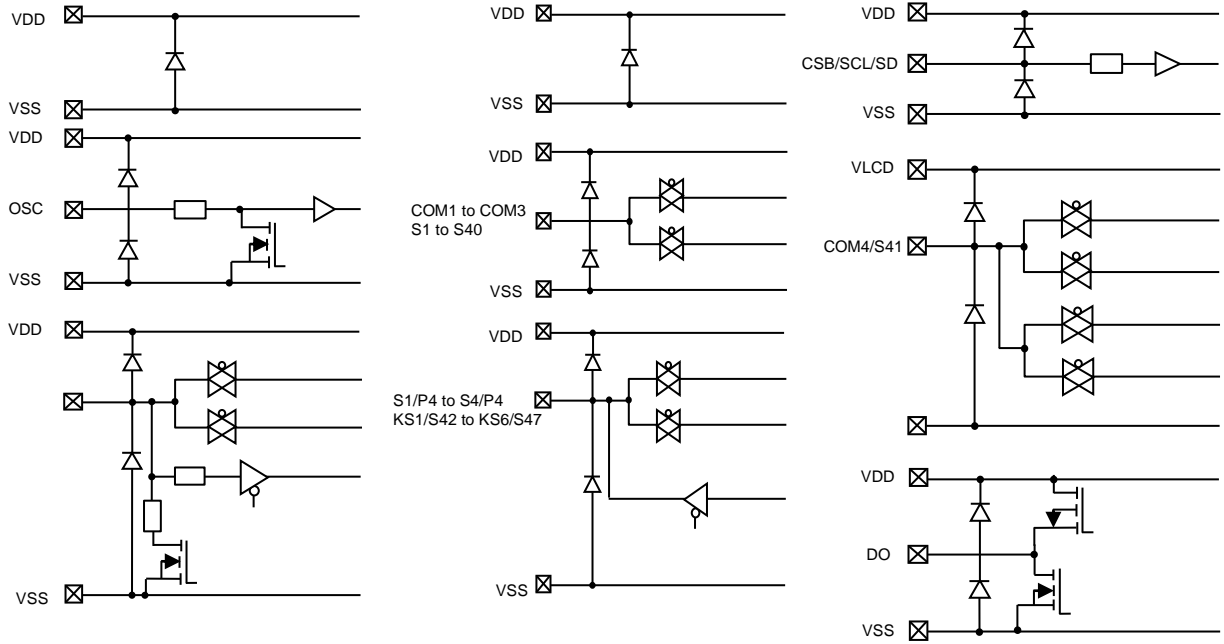

Figure 6. I/O equivalent circuit

**Function descriptions**

Command and Data Transfer Method

3-SPI (3-wire Serial Interface)

This device is controlled by a 3-wire signal (CSB, SCL, and SD).

First, Interface counter is initialized with CSB="H"

Setting CSB="L" enables SD and SCL inputs.

First, Interface counter is initialized with CSB="H", and then CSB="L" makes SD and SCL input enable.

The protocol of 3-SPI transfer is shown as follows.

Each command starts with D7 bit as MSB data, followed by D6 to D0 (this is while CSB = "L").

(Internal data is latched at the rising edge of SCL, then the data is converted to an 8-bit parallel data at the falling edge of the 8th CLK.)

When you rise CSB = "H", in case command less than 8bit, command and data are canceled.

(1) Write Mode

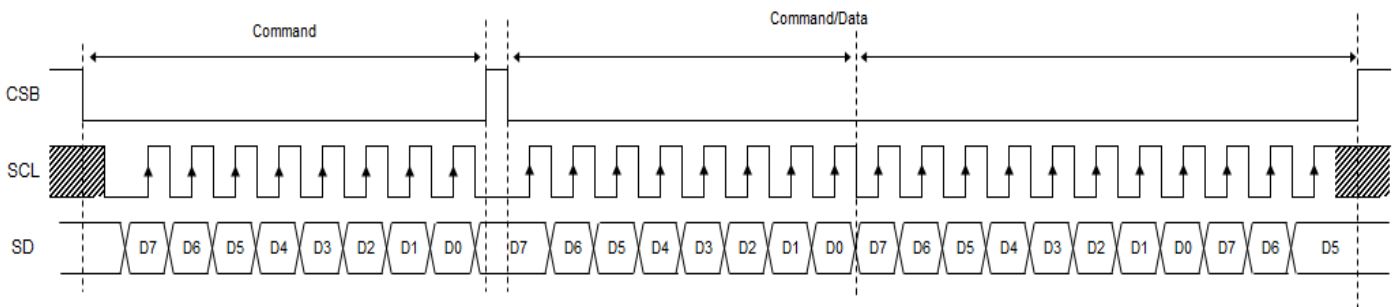

**Figure 7. 3-SPI Data Transfer Format**

(2) Read Mode (KEY RD command only)

The following occurs when Key Read by KEY RD command.

If KEY RD command is recognized at the rising edge of 8th CLK, it enters Read mode after the falling edge of 8th CLK and then key data is output through DO.

Setting CSB="H" can exit Read mode after or during Serial Data Transfer.

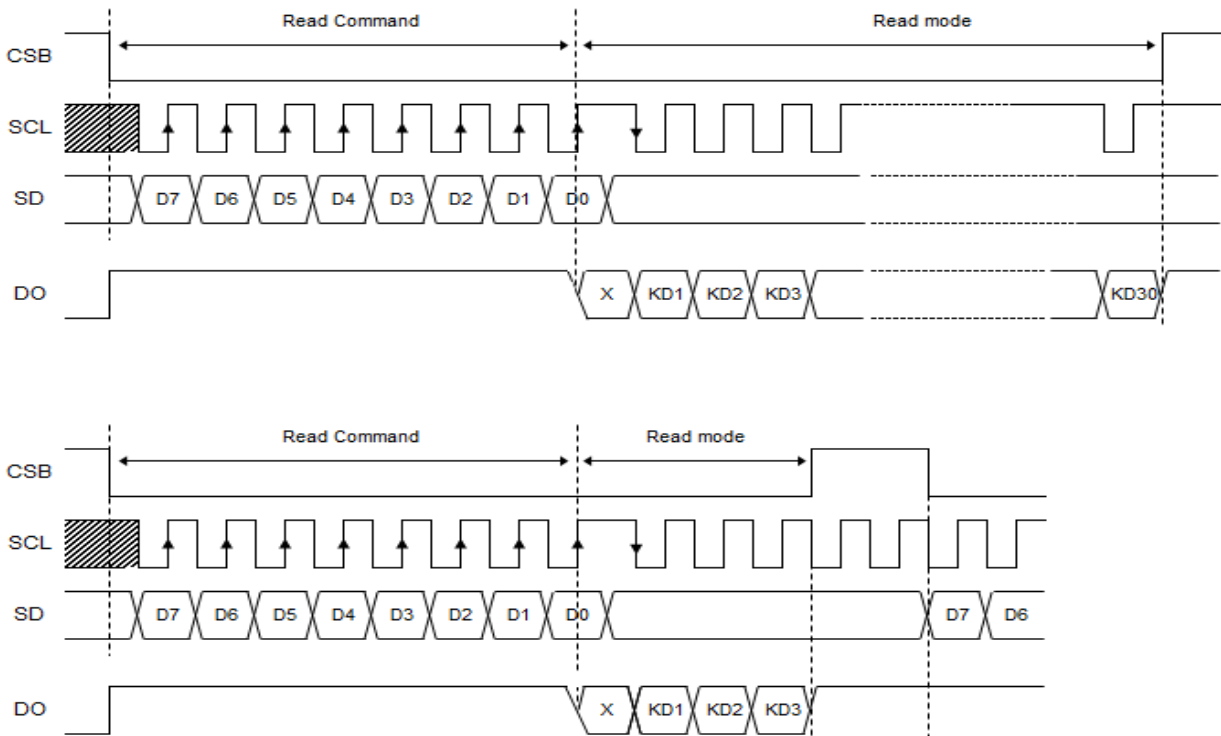

**Figure 8. Serial Data Output Format**

**Function descriptions – continued**

Command Transfer Method

After CSB="H"→"L", the 1st byte shall be a command.

Please refer to "Command Table".

When set command except Data write(DATAWR), the next byte will be (continuously) a command.

When set DATAWR command, the following bytes will be display data bytes.

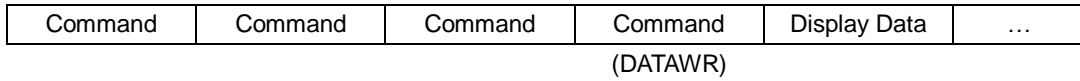

Once it becomes display data transfer mode, it will not be able to send command.

If you send command again, please rise CSB="H".

Display Data Transfer Method

This LSI has Display Data RAM (DDRAM) of 51×4=204bit.

The relationship between data input and display data, DDRAM data and address are as follows.

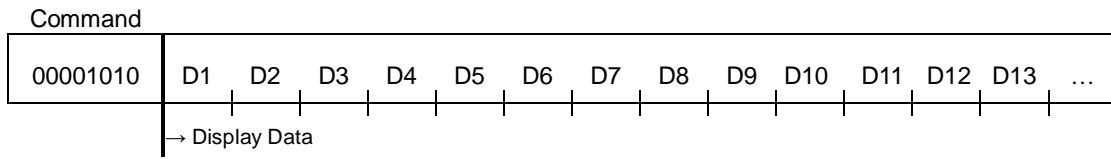

Display data will be stored in DDRAM. The address to be written is specified by Address set (ADSET) command and the address is automatically incremented in every 4bit data if 1/4 Duty mode or in every 3 bit if 1/3 Duty mode respectively.

1/3 Duty Mode

		DDRAM Address/Segment Outputs											
		00h	01h	02h	...	27h	28h	29h	...	31h	32h	33h	
BIT	0	D1	D4	D7		D118	D121	D124		D148	D151	D154	COM1
	1	D2	D5	D8		D119	D122	D125		D149	D152	D155	COM2
	2	D3	D6	D9		D120	D123	D126		D150	D153	D156	COM3
		S1	S2	S3		S40	S41	S42		S50	S51	S52	

Transferred data is written to the DDRAM by every 3bits. The write operation is cancelled if it changes CSB="L"→"H" before 3bits data transfer.

1/4 Duty Mode

		DDRAM Address/ Segment Outputs											
		00h	01h	02h	...	27h	28h	29h	...	30h	31h	32h	
BIT	0	D1	D5	D9		D157	D161	D165		D193	D197	D201	COM1
	1	D2	D6	D10		D158	D162	D166		D194	D198	D202	COM2
	2	D3	D7	D11		D159	D163	D167		D195	D199	D203	COM3
	3	D4	D8	D12		D160	D164	D168		D196	D200	D204	COM4
		S1	S2	S3		S40	S42	S43		S50	S51	S52	

Transferred Data is written to the DDRAM by every 4bits. The write operation is cancelled if it changes CSB="L"→"H" before 4bits data transfer.



## Function descriptions – continued

Relationship between Display Data and Segment Output Pins  
1/3 Duty Mode

output terminal	COM1	COM2	COM3	Address (Hex)	output terminal	COM1	COM2	COM3	Address (Hex)
S1/P1	D1	D2	D3	00	S27	D79	D80	D81	1A
S2/P2	D4	D5	D6	01	S28	D82	D83	D84	1B
S3/P3	D7	D8	D9	02	S29	D85	D86	D87	1C
S4/P4	D10	D11	D12	03	S30	D88	D89	D90	1D
S5	D13	D14	D15	04	S31	D91	D92	D93	1E
S6	D16	D17	D18	05	S32	D94	D95	D96	1F
S7	D19	D20	D21	06	S33	D97	D98	D99	20
S8	D22	D23	D24	07	S34	D100	D101	D102	21
S9	D25	D26	D27	08	S35	D103	D104	D105	22
S10	D28	D29	D30	09	S36	D106	D107	D108	23
S11	D31	D32	D33	0A	S37	D109	D110	D111	24
S12	D34	D35	D36	0B	S38	D112	D113	D114	25
S13	D37	D38	D39	0C	S39	D115	D116	D117	26
S14	D40	D41	D42	0D	S40	D118	D119	D120	27
S15	D43	D44	D45	0E	COM4/S41	D121	D122	D123	28
S16	D46	D47	D48	0F	KS1/S42	D124	D125	D126	29
S17	D49	D50	D51	10	KS2/S43	D127	D128	D129	2A
S18	D52	D53	D54	11	KS3/S44	D130	D131	D132	2B
S19	D55	D56	D57	12	KS4/S45	D133	D134	D135	2C
S20	D58	D59	D60	13	KS5/S46	D136	D137	D138	2D
S21	D61	D62	D63	14	KS6/S47	D139	D140	D141	2E
S22	D64	D65	D66	15	KI1/S48	D142	D143	D144	2F
S23	D67	D68	D69	16	KI2/S49	D145	D146	D147	30
S24	D70	D71	D72	17	KI3/S50	D148	D149	D150	31
S25	D73	D74	D75	18	KI4/S51	D151	D152	D153	32
S26	D76	D77	D78	19	KI5/S52	D154	D155	D156	33

(Note) In case of S1/P1 to S4/P4, COM4/S41, KS1/S42 to KS6/S47 and KI1/S48 to KI5/S52 are selected for segment output.

For example, S11 output case

Bits in a DDRAM			Segment Output Pin (S11)
D31	D32	D33	
0	0	0	Off-state of the LCD elements corresponding to COM1, 2 and 3
0	0	1	On-state of the LCD element corresponding to COM3
0	1	0	On-state of the LCD element corresponding to COM2
0	1	1	On-state of the LCD elements corresponding to COM2 and 3
1	0	0	On-state of the LCD element corresponding to COM1
1	0	1	On-state of the LCD elements corresponding to COM1 and 3
1	1	0	On-state of the LCD elements corresponding to COM1 and 2
1	1	1	On-state of the LCD elements corresponding to COM1, 2 and 3

## Function descriptions – continued

## 1/4 Duty Mode

output terminal	COM1	COM2	COM3	COM4	Address (Hex)	output terminal	COM1	COM2	COM3	COM4	Address (Hex)
S1/P1	D1	D2	D3	D4	00	S27	D105	D106	D107	D108	1A
S2/P2	D5	D6	D7	D8	01	S28	D109	D110	D111	D112	1B
S3/P3	D9	D10	D11	D12	02	S29	D113	D114	D115	D116	1C
S4/P4	D13	D14	D15	D16	03	S30	D117	D118	D119	D120	1D
S5	D17	D18	D19	D20	04	S31	D121	D122	D123	D124	1E
S6	D21	D22	D23	D24	05	S32	D125	D126	D127	D128	1F
S7	D25	D26	D27	D28	06	S33	D129	D130	D131	D132	20
S8	D29	D30	D31	D32	07	S34	D133	D134	D135	D136	21
S9	D33	D34	D35	D36	08	S35	D137	D138	D139	D140	22
S10	D37	D38	D39	D40	09	S36	D141	D142	D143	D144	23
S11	D41	D42	D43	D44	0A	S37	D145	D146	D147	D148	24
S12	D45	D46	D47	D48	0B	S38	D149	D150	D151	D152	25
S13	D49	D50	D51	D52	0C	S39	D153	D154	D155	D156	26
S14	D53	D54	D55	D56	0D	S40	D157	D158	D159	D160	27
S15	D57	D58	D59	D60	0E	KS1/S42	D161	D162	D163	D164	28
S16	D61	D62	D63	D64	0F	KS2/S43	D165	D166	D167	D168	29
S17	D65	D66	D67	D68	10	KS3/S44	D169	D170	D171	D172	2A
S18	D69	D70	D71	D72	11	KS4/S45	D173	D174	D175	D176	2B
S19	D73	D74	D75	D76	12	KS5/S46	D177	D178	D179	D180	2C
S20	D77	D78	D79	D80	13	KS6/S47	D181	D182	D183	D184	2D
S21	D81	D82	D83	D84	14	KI1/S48	D185	D186	D187	D188	2E
S22	D85	D86	D87	D88	15	KI2/S49	D189	D190	D191	D192	2F
S23	D89	D90	D91	D92	16	KI3/S50	D193	D194	D195	D196	30
S24	D93	D94	D95	D96	17	KI4/S51	D197	D198	D199	D200	31
S25	D97	D98	D99	D100	18	KI5/S52	D201	D202	D203	D204	32
S26	D101	D102	D103	D104	19						

(Note) In case of S1/P1 to S4/P4, KS1/S42 to KS6/S47 and KI1/S48 to KI5/S52 are selected for segment output.

For example, S11 output case

Bits in the DDRAM				Segment Output Pin (S11)
D41	D42	D43	D44	
0	0	0	0	Off-state of the LCD elements corresponding to COM1,2,3 and4
0	0	0	1	On-state of the LCD element corresponding to COM4
0	0	1	0	On-state of the LCD element corresponding to COM3
0	0	1	1	On-state of the LCD elements corresponding to COM3 and 4
0	1	0	0	On-state of the LCD element corresponding to COM2
0	1	0	1	On-state of the LCD elements corresponding to COM2 and 4
0	1	1	0	On-state of the LCD elements corresponding to COM2 and 3
0	1	1	1	On-state of the LCD elements corresponding to COM2,3 and 4
1	0	0	0	On-state of the LCD element corresponding to COM1
1	0	0	1	On-state of the LCD elements corresponding to COM1 and 4
1	0	1	0	On-state of the LCD elements corresponding to COM1 and 3
1	0	1	1	On-state of the LCD elements corresponding to COM1, 3 and 4
1	1	0	0	On-state of the LCD elements corresponding to COM1 and 2
1	1	0	1	On-state of the LCD elements corresponding to COM1,2 and 4
1	1	1	0	On-state of the LCD elements corresponding to COM1,2 and 3
1	1	1	1	On-state of the LCD elements corresponding to COM1,2 3 and 4

Serial Data Output

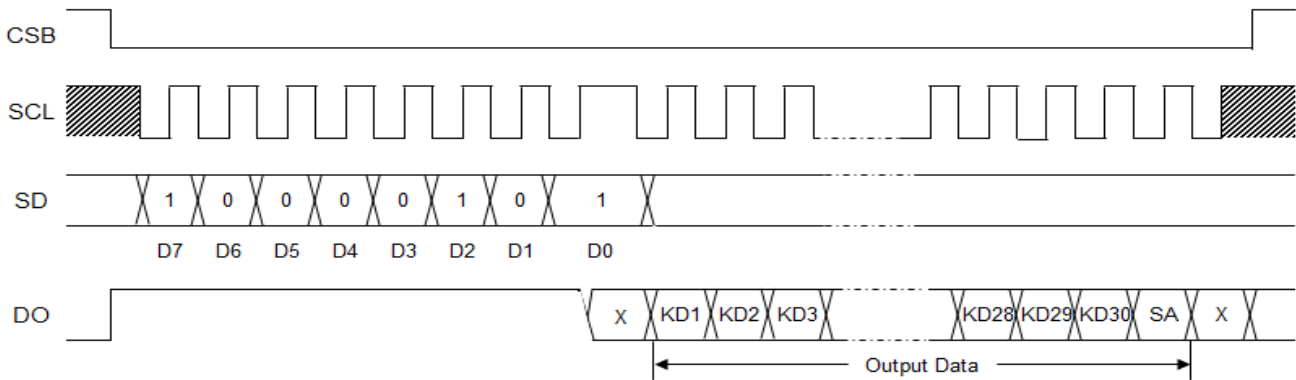

Figure 9. Serial Data Output

KD1 to KD30: Key Data

SA: Sleep Acknowledge Data

Key Data Read Command (KEY RD): 1000\_0101

(Note) If a key data operation is executed when DO is high, the read key data (KD1 to KD30) and sleep acknowledge data(SA) will be invalid.

Output Data

KD1 to KD30: Key Data

When a key matrix of up to 30 keys is formed from the KS1 to KS6 output pins and the KI1 to KI5 input pins and one of those keys is pressed, the key output data corresponding to that key will be set to 1. The table shows the relationship between those pins and the key data bits.

	KI1	KI2	KI3	KI4	KI5
KS1	KD1	KD2	KD3	KD4	KD5
KS2	KD6	KD7	KD8	KD9	KD10
KS3	KD11	KD12	KD13	KD14	KD15
KS4	KD16	KD17	KD18	KD19	KD20
KS5	KD21	KD22	KD23	KD24	KD25
KS6	KD26	KD27	KD28	KD29	KD30

SA: Sleep Acknowledge Data

This output data is used to set the state when the key is pressed. In this case, DO will go to the low level. If serial data is input during this period and the mode is set (normal mode or sleep mode), the IC will be set to that mode. SA is set to 0 in the sleep mode and to 1 in the normal mode.

**Key Scan Operation**

Key Scan Timing

The key scan period is 288T(s). To reliably determine the on/off state of the keys, the BU97501KV scans the keys twice and determines that a key has been pressed when the key data agrees. It outputs a key data read request (a low level on DO) 615T(s) after starting a key scan. If the key data does not agree and a key is pressed at that point, it scans the keys again. Thus, BU97501KV cannot detect a key press shorter than 615T(s).

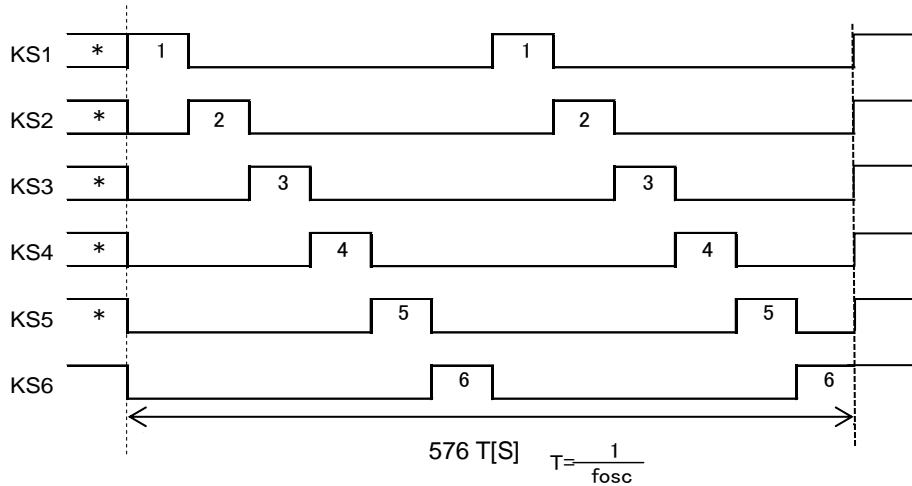

**Figure 10. Key Scan Timing**

Normal Mode

KS1/S42 - KS6/S47 pins are set high.

When a key is pressed, a key scan is started and the keys are scanned until all keys are released. Multiple key presses are recognized by determining whether multiple key data bits are set.

If a key is pressed for longer than 615 T(s) (Where  $T = 1/f_{osc}$  (When External clock input,  $f_{osc}$  is a quarter of external clock)), the BU97501KV outputs a key data read request (a low level on DO) to the controller. The controller acknowledges this request and reads the key data. However, if CSB is "L" during a serial data transfer, DO will be set high.

After the controller reads the key data, the key data read request is cleared (DO is set high) and BU97501KV performs another key scan. Also note that DO can be controlled to be an open-drain output or a CMOS output. If set to be an open-drain output, a pull-up resistor (between 1kΩ and 10kΩ) is required.

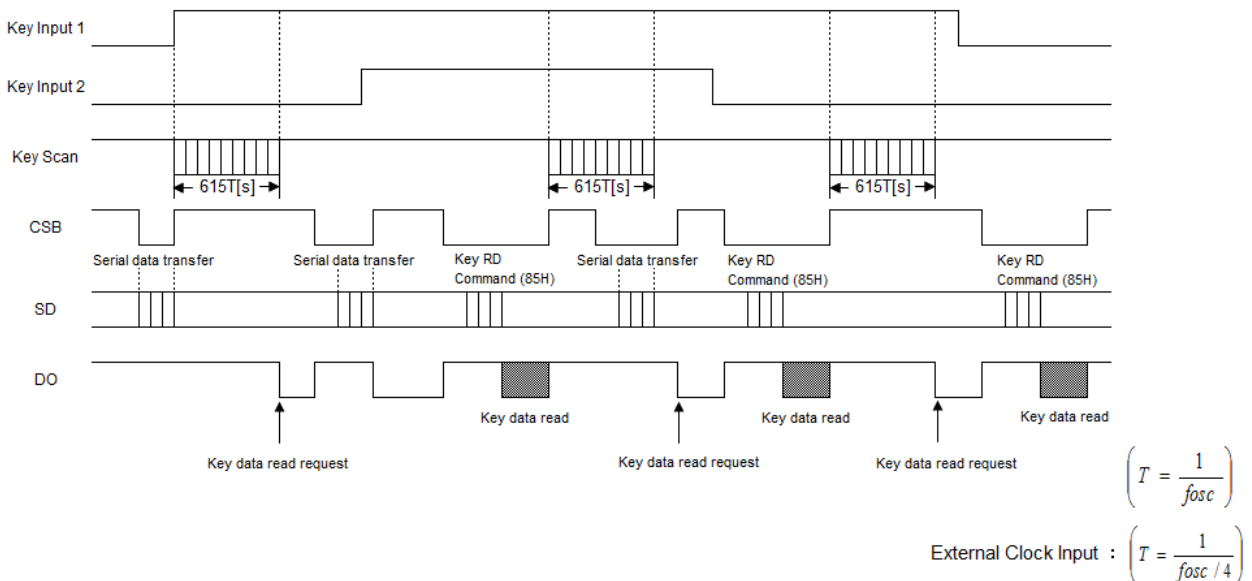

**Figure 11. Key scan operation in normal mode**

**Key Scan Operation – continued**

Sleep Mode

KS1/S42 - KS6/S47 pins are set high or low by SLP CTRL P3,P2 data. (Refer to the SLP CTRL description).

If a key on one of the lines corresponding to a KS1 to KS6 pin which is set high is pressed, the oscillator on the OSC pin is started and a key scan is performed. Keys are scanned until all keys are released. Multiple key presses are recognized by determining whether multiple key data bits are set.

If a key is pressed for longer than 615T(s)(Where  $T=1/f_{osc}$  (When External clock input,  $f_{osc}$  is a quarter of external clock)) the BU97501KV outputs a key data read request (a low level on DO) to the controller. The controller acknowledges this request and reads the key data.

However, if CSB is "L" during a serial data transfer, DO will be set high. After the controller reads the key data, the key data read request is cleared (DO is set high) and the BU97501KV performs another key scan. However, this does not clear sleep mode. Also note that DO can be controlled to be an open-drain output or a CMOS output. During open-drain output selection, DO is an open-drain output so a pull-up resistor (between 1 kΩ and 10kΩ) is required.

Sleep mode key scan example

Example: when SLP CTRL P3= [0], P2= [1] (sleep with only KS6 high)

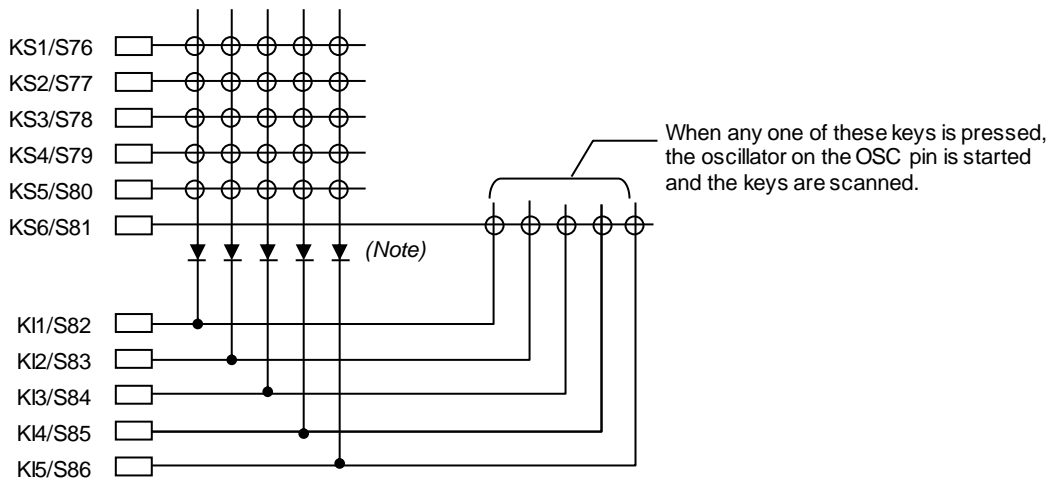

(Note) These diodes are required to reliably recognize multiple key presses on the KS6 line when sleep mode state with only KS6 high, as in the above example. That is, these diodes prevent incorrect operations due to sneak currents in the KS6 key scan output signal when keys on the KS1 to KS5 lines are pressed at the same time.

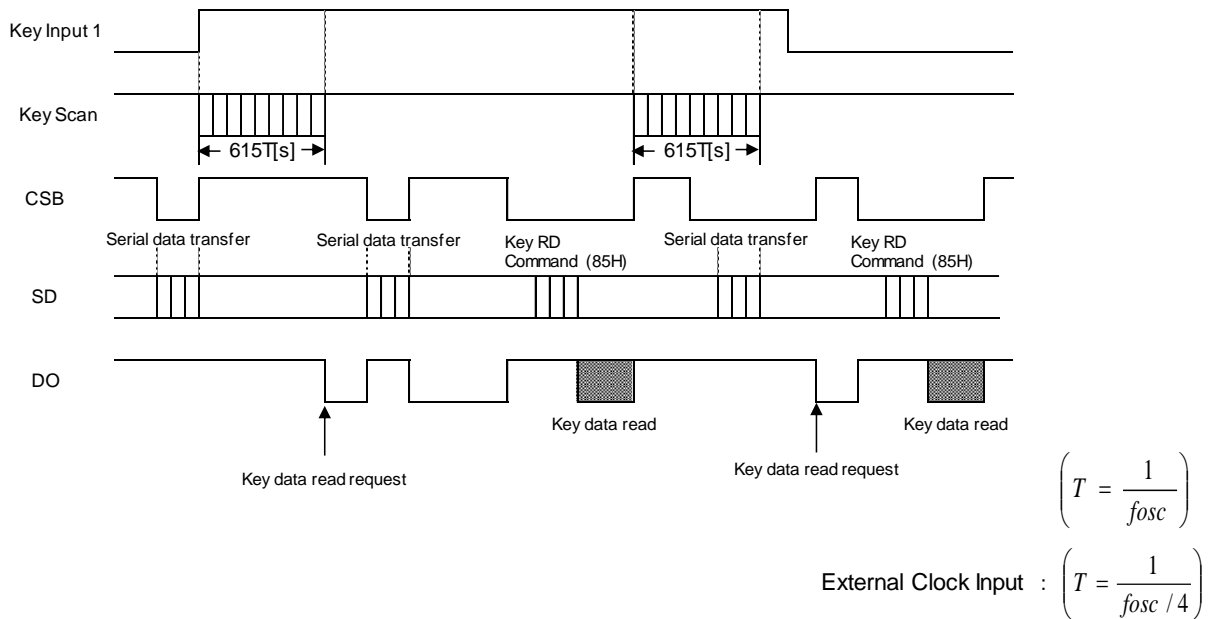

Figure 12. Key scan operation in sleep mode

**Multiple Key Presses**

Although the BU97501KV is capable of key scanning without inserting diodes for dual key presses, triple key presses on the KI1 to KI5 input pin lines, or multiple key presses on the KS1 to KS6 output pin lines, multiple presses other than these cases may result in keys that were not pressed recognized as having been pressed. Therefore, a diode must be inserted in series with each key. Applications that do not recognize multiple key presses of three or more keys should check the key data for three or more 1 bit and ignore such data.

**OSCILLATOR**

Several kinds of clock for logic and analog circuits are generated from internal oscillation circuit or external clock. The OSC pins are open or connected to VSS if the internal oscillator is used.

(Note) To use external clock mode, please set in DRVCTRL1 command. If you select "External Clock input", external clock can be inputted.

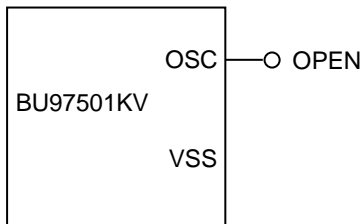

Figure 13. Internal clock mode

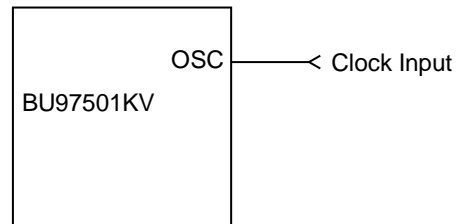

Figure 14. External clock mode

**LCD Driver Bias/Duty Circuit**

This LSI generates LCD driving voltage with on-chip Buffer AMP. And it can drive LCD at low power consumption.

\* 1/3 or 1/2Bias and line or frame inversion mode can be selected by DRV CTRL2.

\* 1/4 or 1/3Duty can be selected by DRV CTRL1 command.

Refer to "LCD waveform" about each LCD waveform.

**LCD waveform**

1/4Duty, 1/3Bias

Line inversion

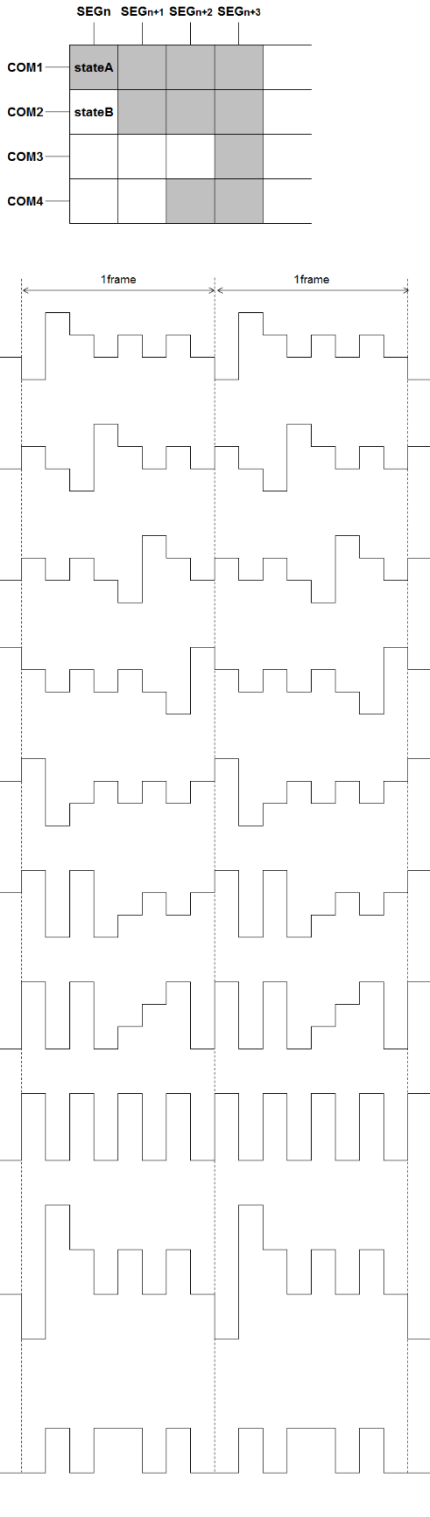

Figure 15. LCD waveform in line inversion

Frame inversion

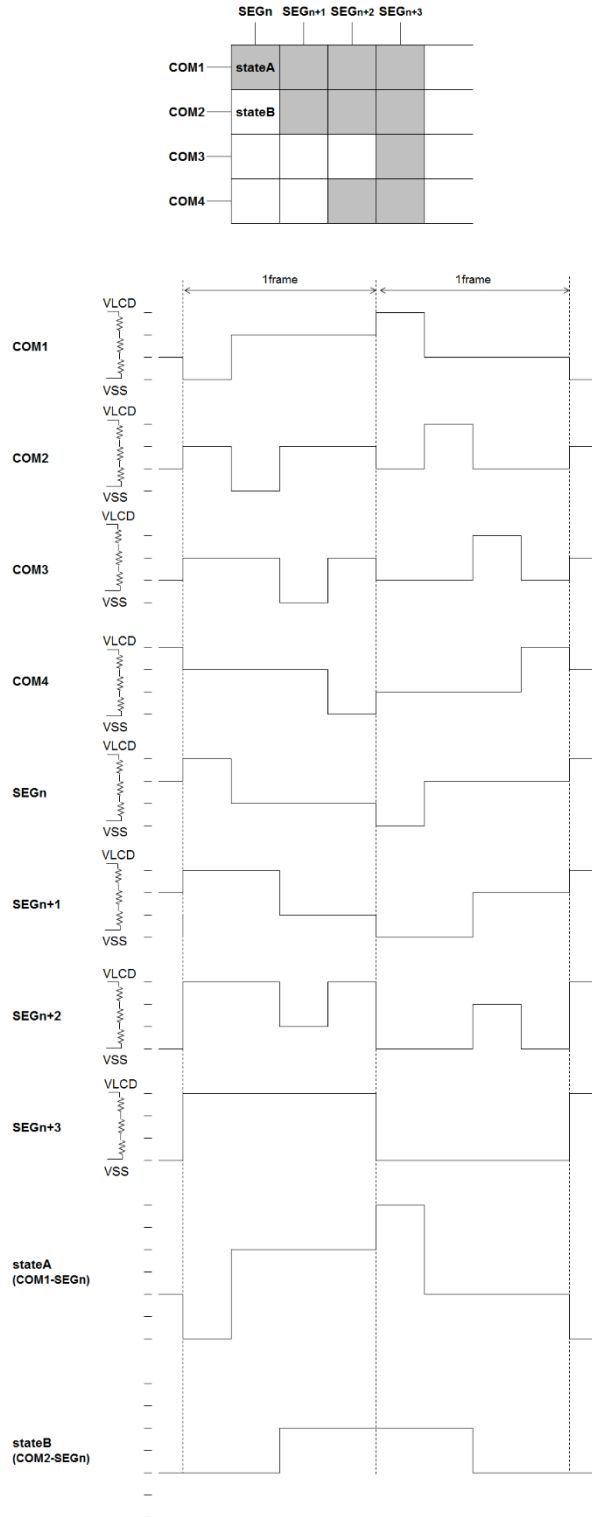

Figure 16. LCD waveform in frame inversion

LCD waveform – continued

1/4Duty, 1/2Bias

Line inversion

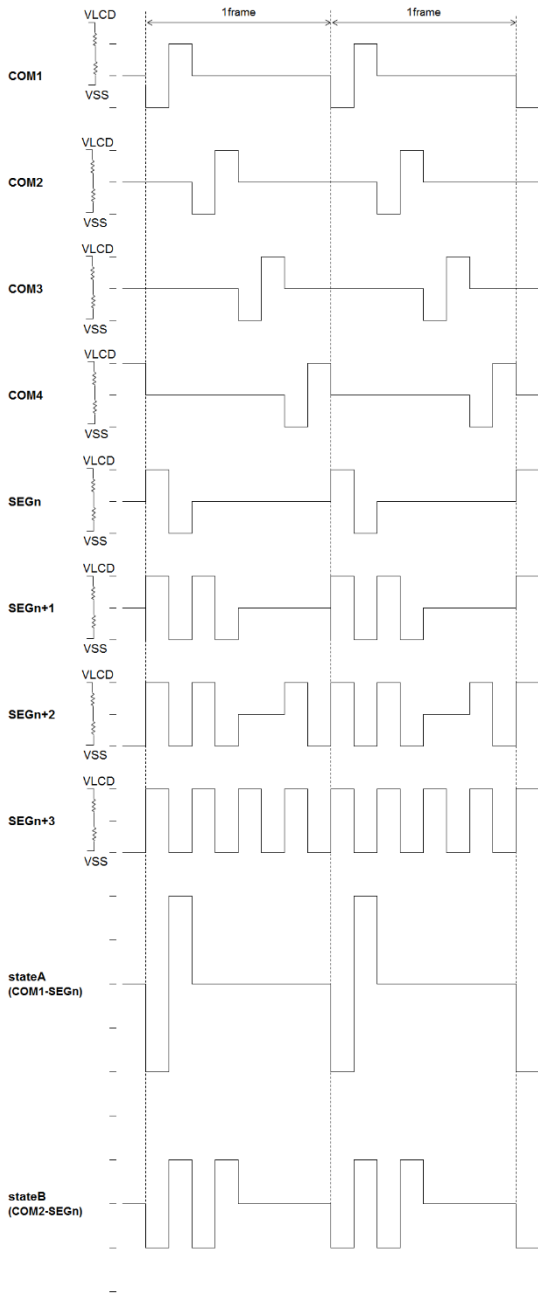
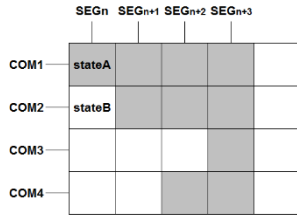

Figure 17. LCD waveform in line inversion

Frame inversion

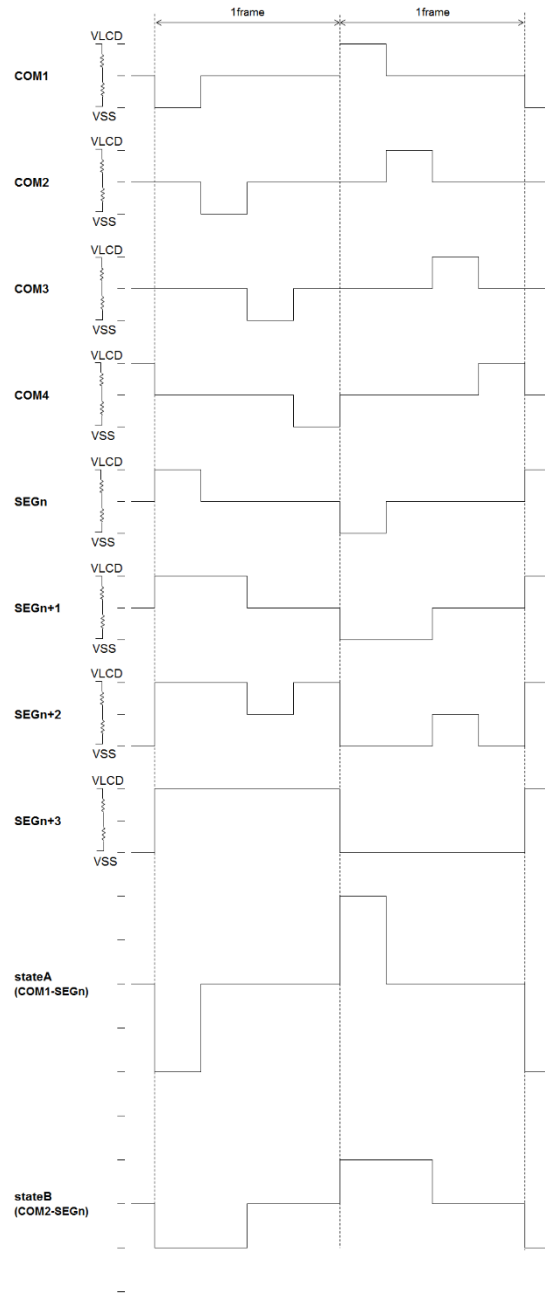
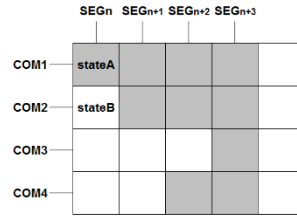

Figure 18. LCD waveform in frame inversion



LCD waveform – continued

1/3Duty, 1/3Bias

Line inversion

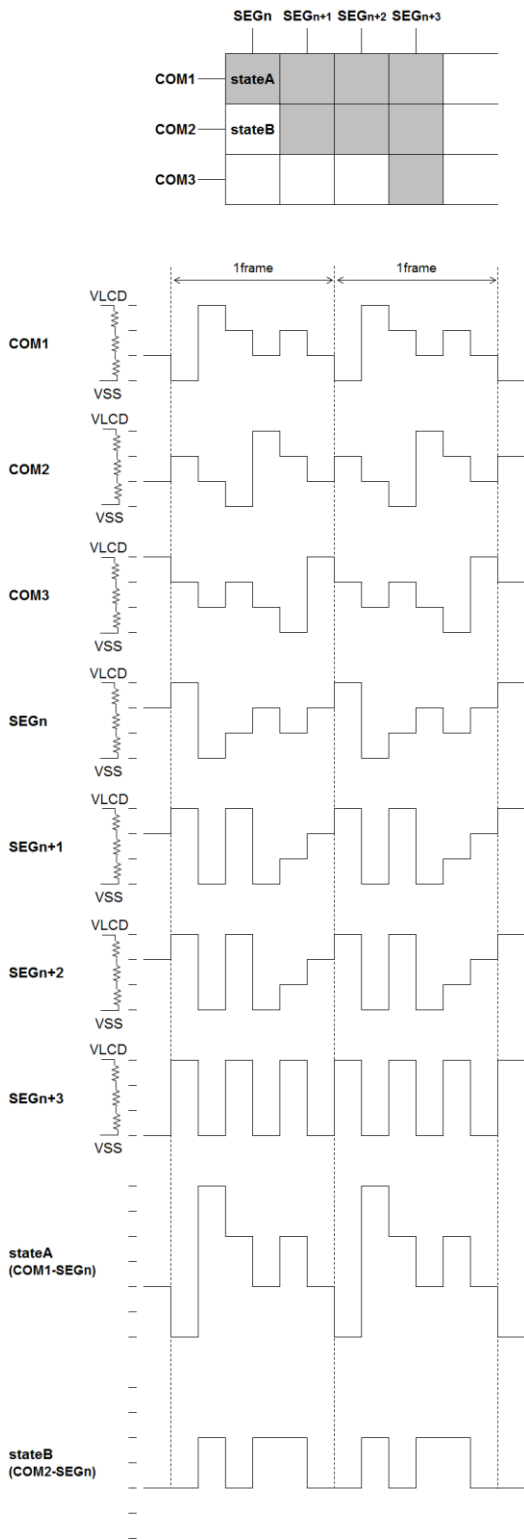

Figure 19. LCD waveform in line inversion

Frame inversion

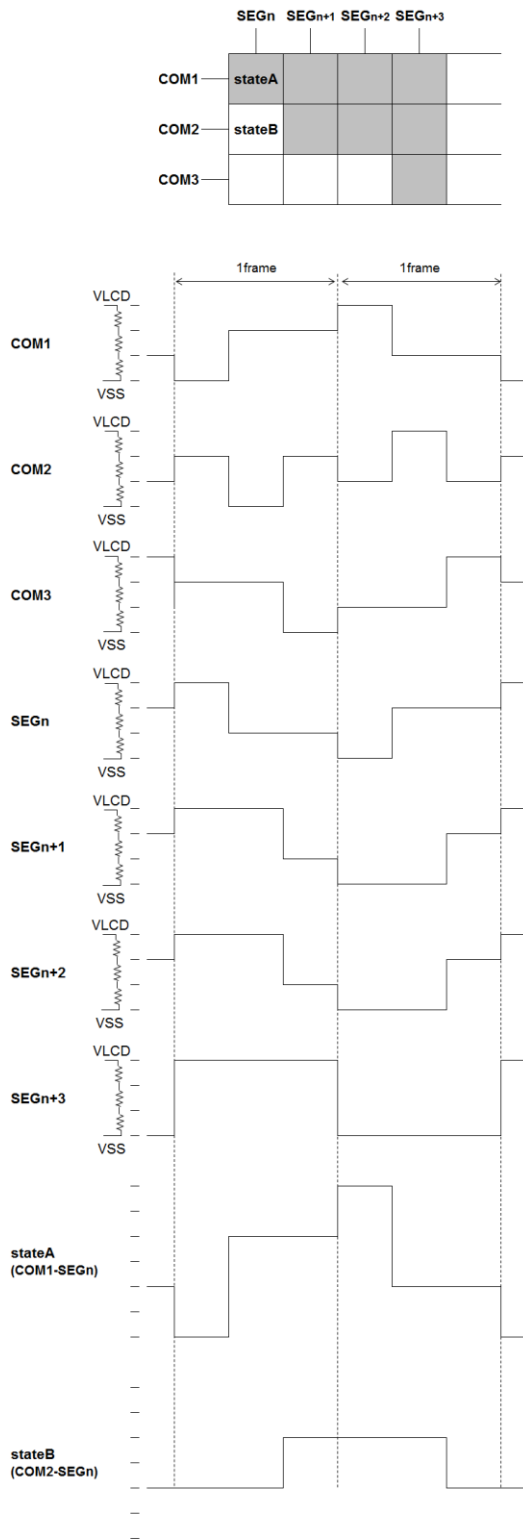

Figure 20. LCD waveform in frame inversion

LCD waveform – continued

1/3Duty, 1/2Bias

Line inversion

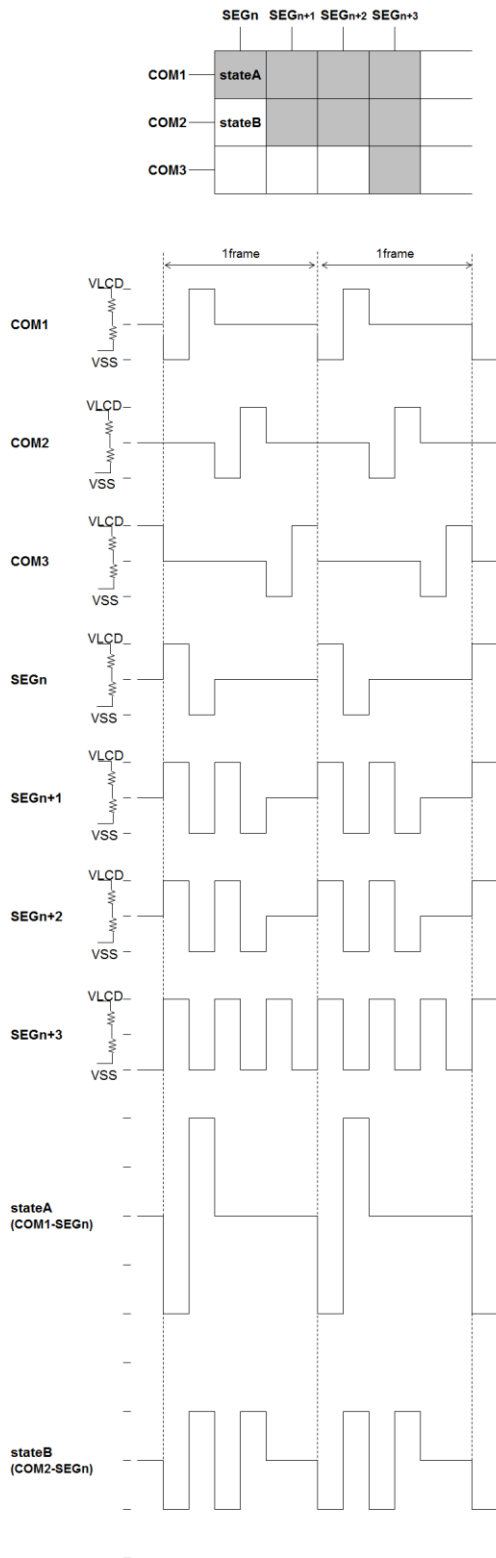

Figure 21. LCD waveform in line inversion

Frame inversion

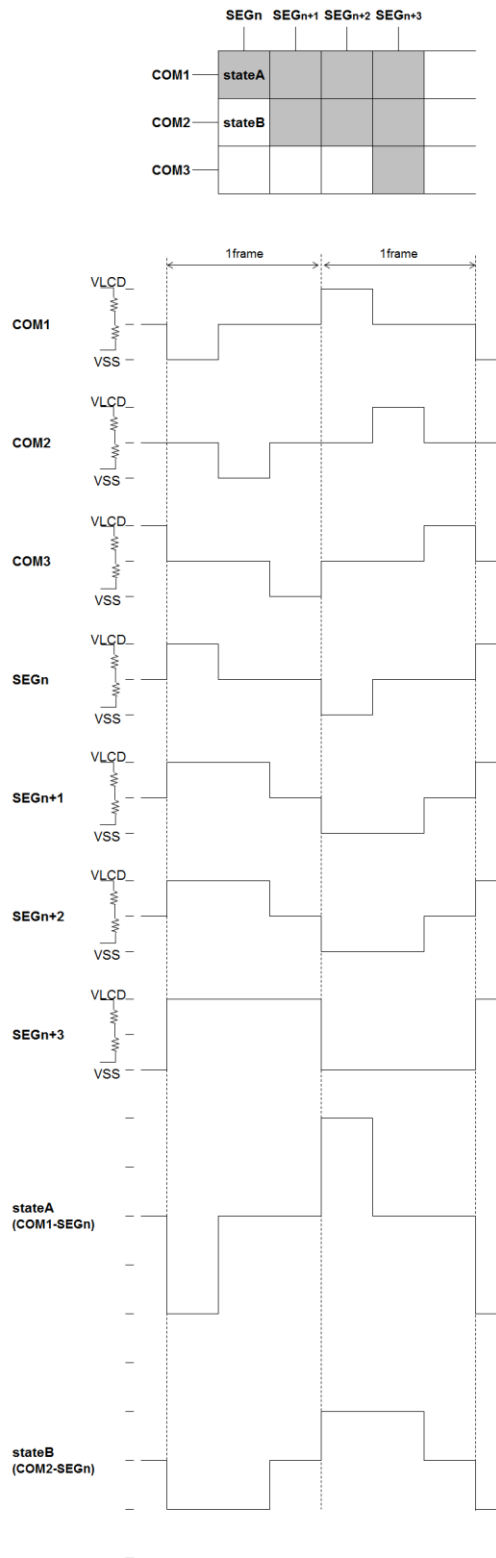

Figure 22. LCD waveform in frame inversion

## Command Table

Command.	BIN								Descriptions
	D7	D6	D5	D4	D3	D2	D1	D0	
SLP CTRL	1	0	0	1	P3	P2	*	*	Sleep Control
SEG CTRL	1	0	1	1	P3	P2	P1	*	Segment Control
DRV CTRL1	1	1	0	0	P3	P2	P1	0	Drive Control1 (Duty Set, OSC Control)
DRV CTRL2	1	1	0	1	0	P2	P1	0	Drive Control2 (Bias Set, Inversion Mode)
DRV CTRL3	1	0	1	0	P3	P2	*	P0	Drive Control3 (Keyscan Output Set, DO Set)
KEY RD	1	0	0	0	0	1	0	1	Key Data Read
SWRST	1	1	1	1	0	0	0	1	Software Reset
DISCTRL	1	1	1	1	1	0	P1	*	Display Control (Display On/Off)
ADSET	0	1	P5	P4	P3	P2	P1	P0	Address Set
DATA WR	0	0	0	0	1	0	1	0	Data Write

(\* : Don't care)

Detailed command description

Sleep Control (SLP CTRL)

MSB						LSB	
D7	D6	D5	D4	D3	D2	D1	D0
1	0	0	1	P3	P2	*	*

(\* : Don't care)

P3, P2: Normal mode/Sleep mode switching control data  
 These control data bits select Key Scan Output Pins KS1 to KS6 States of during Key Scan Standby.

Control bits		Mode	Internal OSC	Segment outputs/Commo n Outputs	Output Pin States During Key Scan Standby						Reset Conditions
P3	P2				KS1	KS2	KS3	KS4	KS5	KS6	
0	0	Normal	enabled	Operating	H	H	H	H	H	H	-
0	1	Sleep	disabled	Low(VSS)	L	L	L	L	L	H	○
1	0	Sleep			L	L	L	L	H	H	-
1	1	Sleep			H	H	H	H	H	H	-

(Note 1) When DRV CTRL3 (P3, P2) = (1, 1), KS1 to KS6 outputs are selected as Segment outputs.

Segment Control (SEG CTRL)

MSB						LSB	
D7	D6	D5	D4	D3	D2	D1	D0
1	0	1	1	P3	P2	P1	*

(\* : Don't care)

P3 to P1 : Segment Output / General purpose output switching control data  
 These control bits select the function of the S1/P1 to S4/P4 output pins.  
 (Segment Output Pins or General Purpose Output Pins).

Control bits			Status of the pins				Reset conditions
P3	P2	P1	S1/P1	S2/P2	S3/P3	S4/P4	
0	0	0	S1	S2	S3	S4	○
0	0	1	P1	S2	S3	S4	-
0	1	0	P1	P2	S3	S4	-
0	1	1	P1	P2	P3	S4	-
1	0	0	P1	P2	P3	P4	-

(Note 2) Sn(n=1 to 4) : assigned as a Segment Output pin  
 Pn(n=1 to 4) : assigned as a General Purpose Output pin

Relationship of bit assignment between general purpose output pin and bit in DDRAM

Output Pin	Corresponding bit in DDRAM	
	1/3 Duty	1/4 Duty
S1/P1	D1	D1
S2/P2	D4	D5
S3/P3	D7	D9
S4/P4	D10	D13

In case of 1/4 Duty mode and S4/P4 is configured as a general purpose output pins.  
 S4/P4 is set to HIGH (VLCD level) if D13 is set to "1" in DDRAM.  
 S4/P4 is cleared to LOW (VSS level) if D13 is set to "0" in DDRAM.

**Detailed command description – continued**

Drive Control1 (DRV CTRL1)

MSB				LSB			
D7	D6	D5	D4	D3	D2	D1	D0
1	1	0	0	P3	P2	P1	0

P3: 1/3 Duty drive or 1/4 Duty drive switching control data  
 This control data bit selects either 1/3 Duty drive or 1/4 Duty drive.

P3	Duty mode	Status of (COM4/ S41)	Reset conditions
0	1/4	COM4	○
1	1/3	S41	-

(Note 1) COM4: COMMON output  
 S41: SEGMENT output

P2,P1 : Frame frequency switching control data  
 These control data bits select Frame frequency setting.

Setting	P2	P1	Reset conditions
80Hz	0	0	○
100Hz	0	1	-
120Hz	1	0	-
External Clock input	1	1	-

Relationships between Frame frequency (f<sub>FR</sub>) and Divide number

P2	P1	Divide number		f <sub>FR</sub> [Hz]	
		1/3 Duty	1/4 Duty	1/3 Duty	1/4 Duty
0	0	510	512	80	80
0	1	408	408	100	100
1	0	342	344	120	120
1	1	2040	2048	-	-

Formula to calculate Frame frequency from frequency and Divide number:  
 “Frame frequency = frequency / Divide number”

Ex) In case, 1/4 Duty mode, (P2,P1) = (0,0)

$$f_{FR} = 40.96[\text{kHz}] / 512 = 80[\text{Hz}]$$

(Note 2) Built-in Oscillator circuit frequency = 40.96 kHz Typ.

<External Clock input timing function>

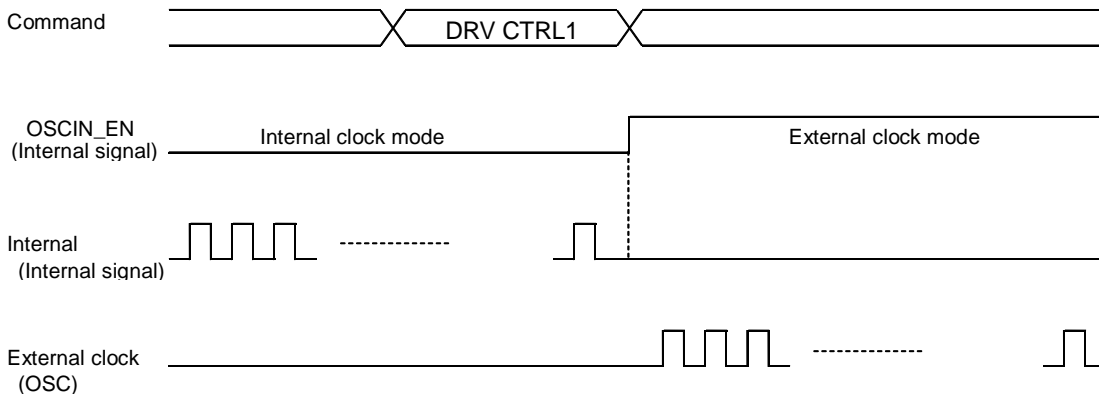

**Detailed command description – continued**

Drive Control2 (DRV CTRL2)

MSB						LSB	
D7	D6	D5	D4	D3	D2	D1	D0
1	1	0	1	0	P2	P1	0

P2: 1/3 Bias drive or 1/2 Bias drive switching control data  
 This control data bit selects either 1/3 Bias drive or 1/2 Bias drive.

P2	Bias mode	Reset conditions
0	1/2	-
1	1/3	○

P1: Line Inversion or Frame Inversion switching control data  
 This control data bit selects either line inversion drive or frame inversion drive.

P1	Inversion mode	Reset conditions
0	Line	○
1	Frame	-

Typically, when driving large capacitance LCD, Line inversion will increase the influence of crosstalk.  
 Regarding driving waveform, refer to [LCD waveform](#).

Drive Control3 (DRV CTRL3)

MSB						LSB	
D7	D6	D5	D4	D3	D2	D1	D0
1	0	1	0	P3	P2	*	P0

(\* : Don't care)

P3 to P2: Key Scan output port/Segment output port switching control data  
 These control data bits select Key Scan outputs or Segment outputs.

Control Bits		Output Pin State						Maximum Number of Input keys	Reset Conditions
P3	P2	KS1/ S42	KS2/ S43	KS3/ S44	KS4/ S45	KS5/ S46	KS6/ S47		
0	0	KS1	KS2	KS3	KS4	KS5	KS6	30	-
0	1	S42	KS2	KS3	KS4	KS5	KS6	25	-
1	0	S42	S43	KS3	KS4	KS5	KS6	20	-
1	1	S42	S43	S44	S45	S46	S47	0	○

When (P3,P2)=(1,1), Keyscan doesn't function. Key scan pins are all segment outputs.  
 Thus, maximum segment display number and RAM last address change based on this value.

Control Bits		Status of Pins						Maximum Segment Display Number		Last Address	
P3	P2	KS1/ S42	KS2/ S43	KS3/ S44	KS4/ S45	KS5/ S46	KS6/ S47	1/3 Duty	1/4 Duty	1/3 Duty	1/4 Duty
0	0	KS1	KS2	KS3	KS4	KS5	KS6	123	160	28h	27h
0	1	S42	KS2	KS3	KS4	KS5	KS6	126	164	29h	28h
1	0	S42	S43	KS3	KS4	KS5	KS6	129	168	2Ah	29h
1	1	S42	S43	S44	S45	S46	S47	156	204	33h	32h

P0: Output setting for DO  
 This control data bit selects either open drain output or CMOS output.

P0	Setting	Reset Conditions
0	open drain output	○
1	CMOS output	-

Pull up resistor (1kΩ to 10kΩ) is required when selecting Open Drain Output setting for DO.  
 Be careful the Pull up voltage not to be higher than VDD voltage.

**Detailed command description – continued**

## Key Data Read (KEY RD)

MSB							LSB
D7	D6	D5	D4	D3	D2	D1	D0
1	0	0	0	0	1	0	1

## Display Control (DISCTRL)

MSB							LSB
D7	D6	D5	D4	D3	D2	D1	D0
1	1	1	1	1	0	P1	*

(\* : Don't care)

P1: Segment on/off control data

This control data bit controls the on/off state of the segments.

P1	Display status	Reset conditions
1	ON	-
0	OFF	○

## Software Reset (SWRST)

MSB							LSB
D7	D6	D5	D4	D3	D2	D1	D0
1	1	1	1	0	0	0	1

This is the Software Reset command.

After sending this command, each register, DDRAM data and DDRAM address are initialized.

## Address Set (ADSET)

MSB							LSB
D7	D6	D5	D4	D3	D2	D1	D0
0	1	P5	P4	P3	P2	P1	P0

Address which could be set starts from 00(Hex) until RAM last address.

Setting of values other than the above is not allowed. (Otherwise, address is set to 0.)

Refer to "[Display Data Transfer Method](#)" for RAM last address.

## Data Write (DATAWR)

MSB							LSB
D7	D6	D5	D4	D3	D2	D1	D0
0	0	0	0	1	0	1	0

Data transfer can be started by this command.

Set the CSB pin to High to terminate the data transfer.

Refer to "[Command and Data Transfer Method](#)".

## Initialize sequence

Recommended sequence after Power-On to set this device to initial condition.

### Software reset sequence

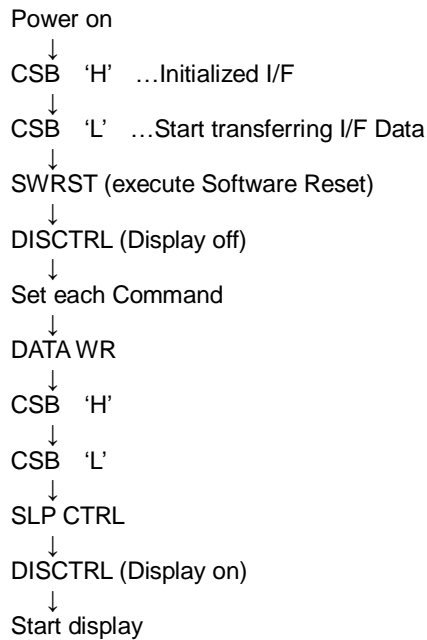

### Hardware reset sequence

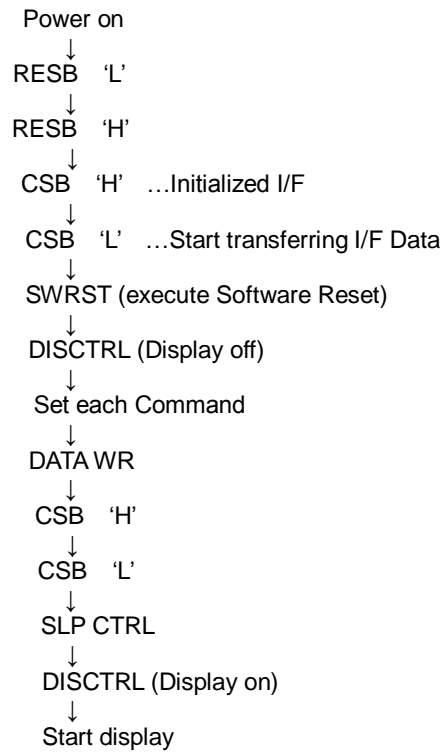

(Note 1) Each register value, DDRAM address and DDRAM data are random condition after power on till initialize sequence is executed.

(Note 2) Each register value, DDRAM address are reset by a hardware reset operation.



**Cautions in Power-On Sequence**

Power-On Reset (POR) Circuit

This LSI has "P.O.R" (Power-On Reset) circuit and Software Reset function. When the power is ON, IC internal circuit and reset pass through unstable low-voltage region. Internal IC is not totally reset because VDD rises and this may result to malfunction. Thus, POR circuit and function of software reset are installed in order to prevent this. Please follow the following recommended Power-On sequences to allow the reset action to complete.

Set the power up conditions to meet the recommended  $t_R$ ,  $t_F$ ,  $t_{OFF}$ , and  $V_{BOT}$  spec below in order to ensure P.O.R operation.

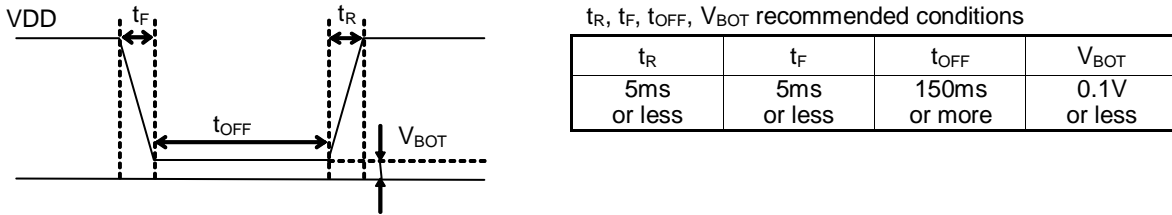

**Figure 23. Power ON/OFF waveform**

If it is difficult to meet above conditions, execute the following sequence after Power-On.

- (1) Set CSB to High
- (2) Clear CSB to Low and then issue a SWRST command.

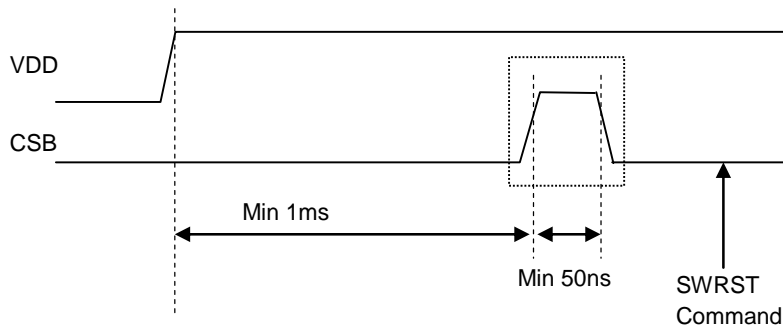
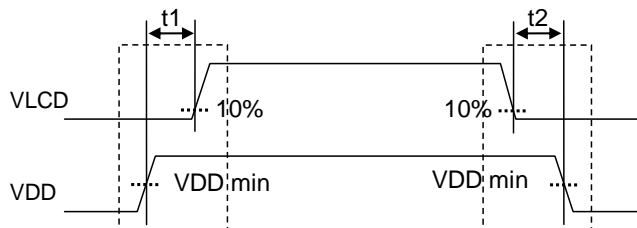

**Figure 24. SWRST Command Sequence**

**Power Up Sequence and Power Down Sequence**

To prevent incorrect display, malfunction and abnormal current, VDD must be turned on before VLCD in power up sequence. VDD must be turned off after VLCD in power down sequence. Please satisfies  $VLCD \geq VDD$ ,  $t1 > 0ns$ ,  $t2 > 0ns$

To refrain from data transmission is strongly recommended while power supply is rising up or falling down to prevent from the occurrence of disturbances on transmission and reception.



**Figure 25. Power On/Off Sequence**

**Display off Operation in External Clock Mode**

After receiving DISCTRL(Display OFF) command, Segment and Common ports output VSS level synchronized with frame. Therefore, in external clock mode, it is necessary to input the external clock based on each frame frequency setting after sending DISCTRL (Display OFF).For the required number of clock, refer to Frame frequency switching control data of Drive Control1(DRV CTRL1).

Please input the external clock as below.

1/4 Duty, DRV CTRL1 [P2,P1=1,1] setting(Frame frequency [Hz] = external clock [Hz] / 2048), it needs 2048 clk or more.

Please refer to the timing chart below.

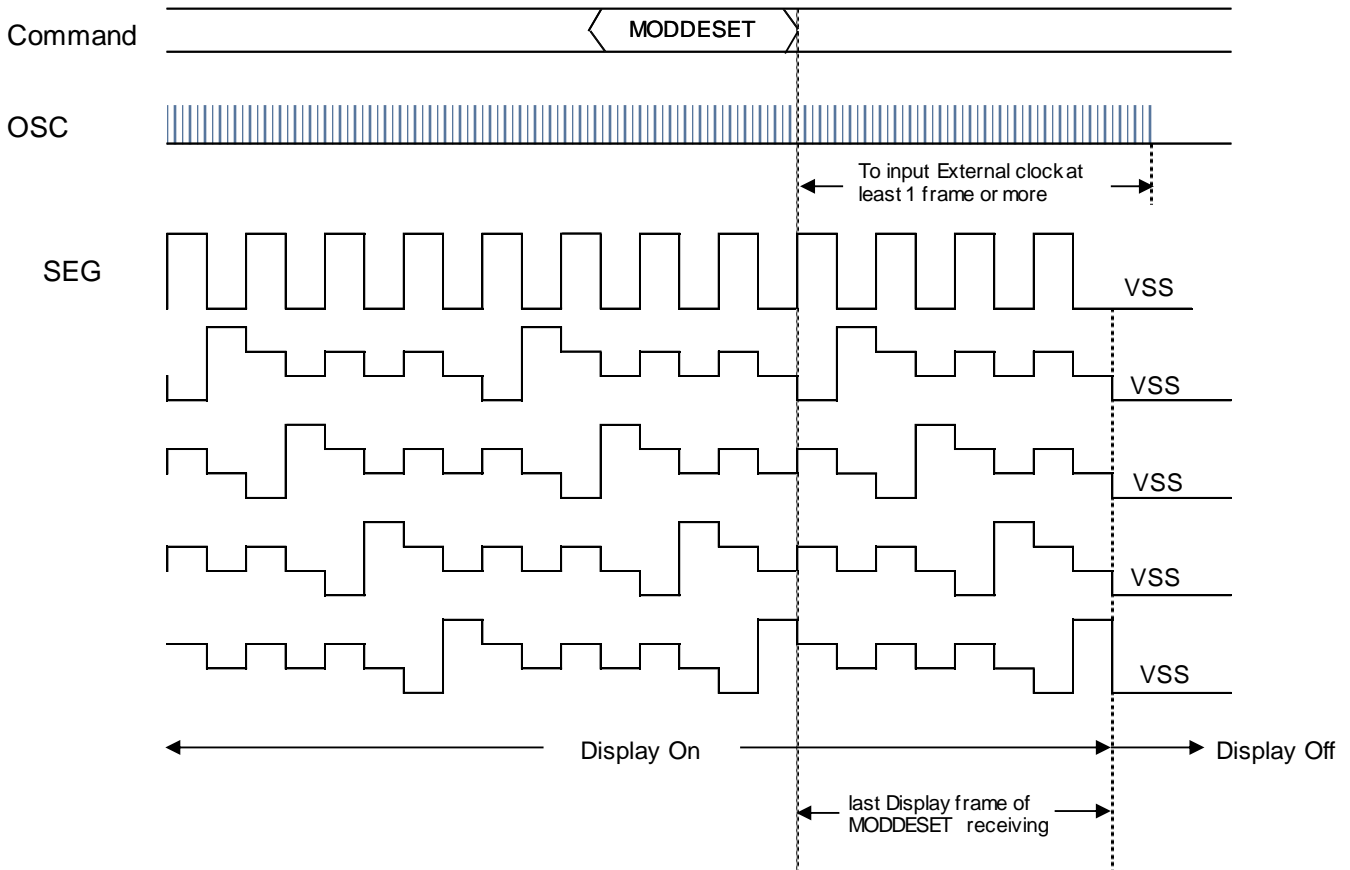

**Figure 26. External Clock Stop Timing**

**DISPLAY DDRAM DATA EXAMPLE**

If LCD layout pattern is shown as in Figure 27 and 28 and DDRAM data is shown as in Table2, display pattern will be shown as in Figure 29.

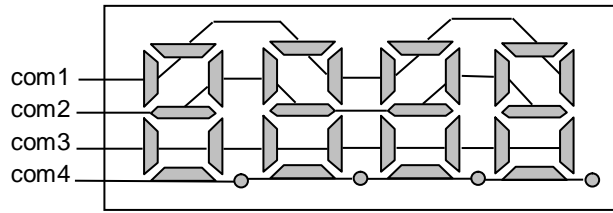

**Figure 27. Example COM Line pattern**

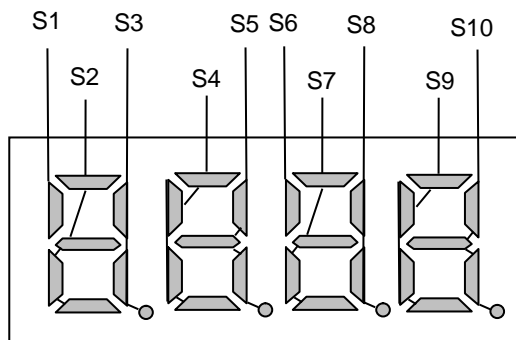

**Figure 28. Example of SEG Line pattern**

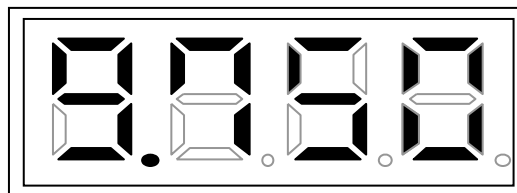

**Figure 29. Example of display pattern**

S  
 1 2 3 4 5 6 7 8 9 10 11 12 13 14 15 16 17 18 19 20

COM1	D0	1	1	0	1	1	1	1	0	1	1	0	0	0	0	0	0	0	0
COM2	D1	0	1	1	1	0	0	1	0	1	0	0	0	0	0	0	0	0	0
COM3	D2	0	0	1	0	1	0	0	1	1	1	0	0	0	0	0	0	0	0
COM4	D3	0	1	1	0	0	0	1	0	1	0	0	0	0	0	0	0	0	0

Address            00h 01h 02h 03h 04h 05h 06h 07h 08h 09h 0Ah 0Bh 0Ch 0Dh 0Eh 0Fh 10h 11h 12h 13h

**Table 2. DDRAM Data map**

## Operational Notes

### 1. Reverse Connection of Power Supply

Connecting the power supply in reverse polarity can damage the IC. Take precautions against reverse polarity when connecting the power supply, such as mounting an external diode between the power supply and the IC's power supply pins.

### 2. Power Supply Lines

Design the PCB layout pattern to provide low impedance supply lines. Separate the ground and supply lines of the digital and analog blocks to prevent noise in the ground and supply lines of the digital block from affecting the analog block. Furthermore, connect a capacitor to ground at all power supply pins. Consider the effect of temperature and aging on the capacitance value when using electrolytic capacitors.

### 3. Ground Voltage

Ensure that no pins are at a voltage below that of the ground pin at any time, even during transient condition.

### 4. Ground Wiring Pattern

When using both small-signal and large-current ground traces, the two ground traces should be routed separately but connected to a single ground at the reference point of the application board to avoid fluctuations in the small-signal ground caused by large currents. Also ensure that the ground traces of external components do not cause variations on the ground voltage. The ground lines must be as short and thick as possible to reduce line impedance.

### 5. Recommended Operating Conditions

These conditions represent a range within which the expected characteristics of the IC can be approximately obtained. The electrical characteristics are guaranteed under the conditions of each parameter.

### 6. Inrush Current

When power is first supplied to the IC, it is possible that the internal logic may be unstable and inrush current may flow instantaneously due to the internal powering sequence and delays, especially if the IC has more than one power supply. Therefore, give special consideration to power coupling capacitance, power wiring, width of ground wiring, and routing of connections.

### 7. Operation Under Strong Electromagnetic Field

Operating the IC in the presence of a strong electromagnetic field may cause the IC to malfunction.

### 8. Testing on Application Boards

When testing the IC on an application board, connecting a capacitor directly to a low-impedance output pin may subject the IC to stress. Always discharge capacitors completely after each process or step. The IC's power supply should always be turned off completely before connecting or removing it from the test setup during the inspection process. To prevent damage from static discharge, ground the IC during assembly and use similar precautions during transport and storage.

### 9. Inter-pin Short and Mounting Errors

Ensure that the direction and position are correct when mounting the IC on the PCB. Incorrect mounting may result in damaging the IC. Avoid nearby pins being shorted to each other especially to ground, power supply and output pin. Inter-pin shorts could be due to many reasons such as metal particles, water droplets (in very humid environment) and unintentional solder bridge deposited in between pins during assembly to name a few.

### 10. Unused Input Terminals

Input terminals of an IC are often connected to the gate of a MOS transistor (CMOS?). The gate has extremely high impedance and extremely low capacitance. If left unconnected, the electric field from the outside can easily charge it. The small charge acquired in this way is enough to produce a significant effect on the conduction through the transistor and cause unexpected operation of the IC. So unless otherwise specified, unused input terminals should be connected to the power supply or ground line.

**Operational Notes – continued****11. Regarding the Input Pin of the IC**

In the construction of this IC, P-N junctions are inevitably formed creating parasitic diodes or transistors. The operation of these parasitic elements can result in mutual interference among circuits, operational faults, or physical damage. Therefore, conditions which cause these parasitic elements to operate, such as applying a voltage to an input pin lower than the ground voltage should be avoided. Furthermore, do not apply a voltage to the input pins when no power supply voltage is applied to the IC. Even if the power supply voltage is applied, make sure that the input pins have voltages within the values specified in the electrical characteristics of this IC.

**12. Ceramic Capacitor**

When using a ceramic capacitor, determine the dielectric constant considering the change of capacitance with temperature and the decrease in nominal capacitance due to DC bias and others.

**13. Area of Safe Operation (ASO)**

Operate the IC such that the output voltage, output current, and power dissipation are all within the Area of Safe Operation (ASO).

**14. Thermal Shutdown Circuit(TSD)**

This IC has a built-in thermal shutdown circuit that prevents heat damage to the IC. Normal operation should always be within the IC's power dissipation rating. If however the rating is exceeded for a continued period, the junction temperature ( $T_j$ ) will rise which will activate the TSD circuit that will turn OFF all output pins. When the  $T_j$  falls below the TSD threshold, the circuits are automatically restored to normal operation.

Note that the TSD circuit operates in a situation that exceeds the absolute maximum ratings and therefore, under no circumstances, should the TSD circuit be used in a set design or for any purpose other than protecting the IC from heat damage.

**15. Over Current Protection Circuit (OCP)**

This IC incorporates an integrated overcurrent protection circuit that is activated when the load is shorted. This protection circuit is effective in preventing damage due to sudden and unexpected incidents. However, the IC should not be used in applications characterized by continuous operation or transitioning of the protection circuit.

Ordering Information

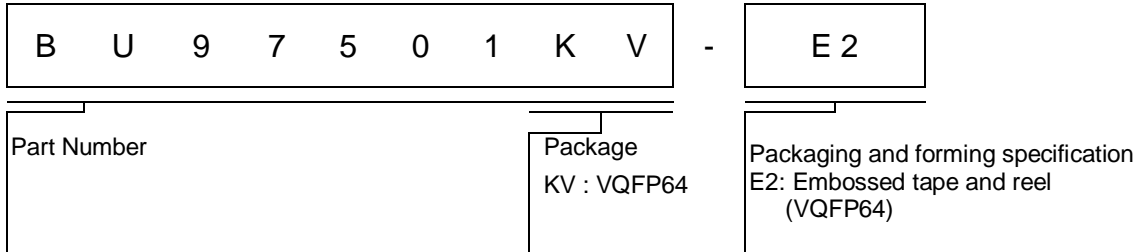

Marking Diagram

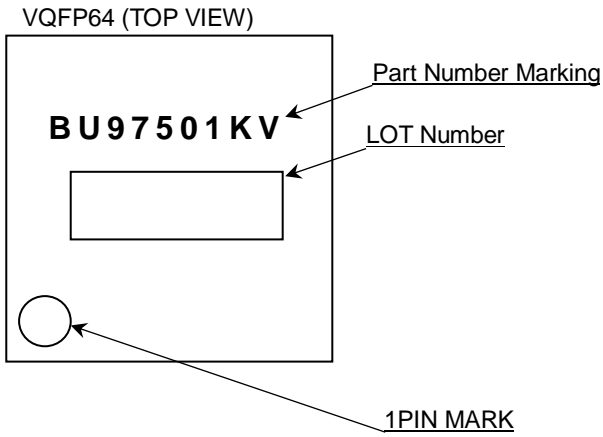

Physical Dimension, Tape and Reel Information

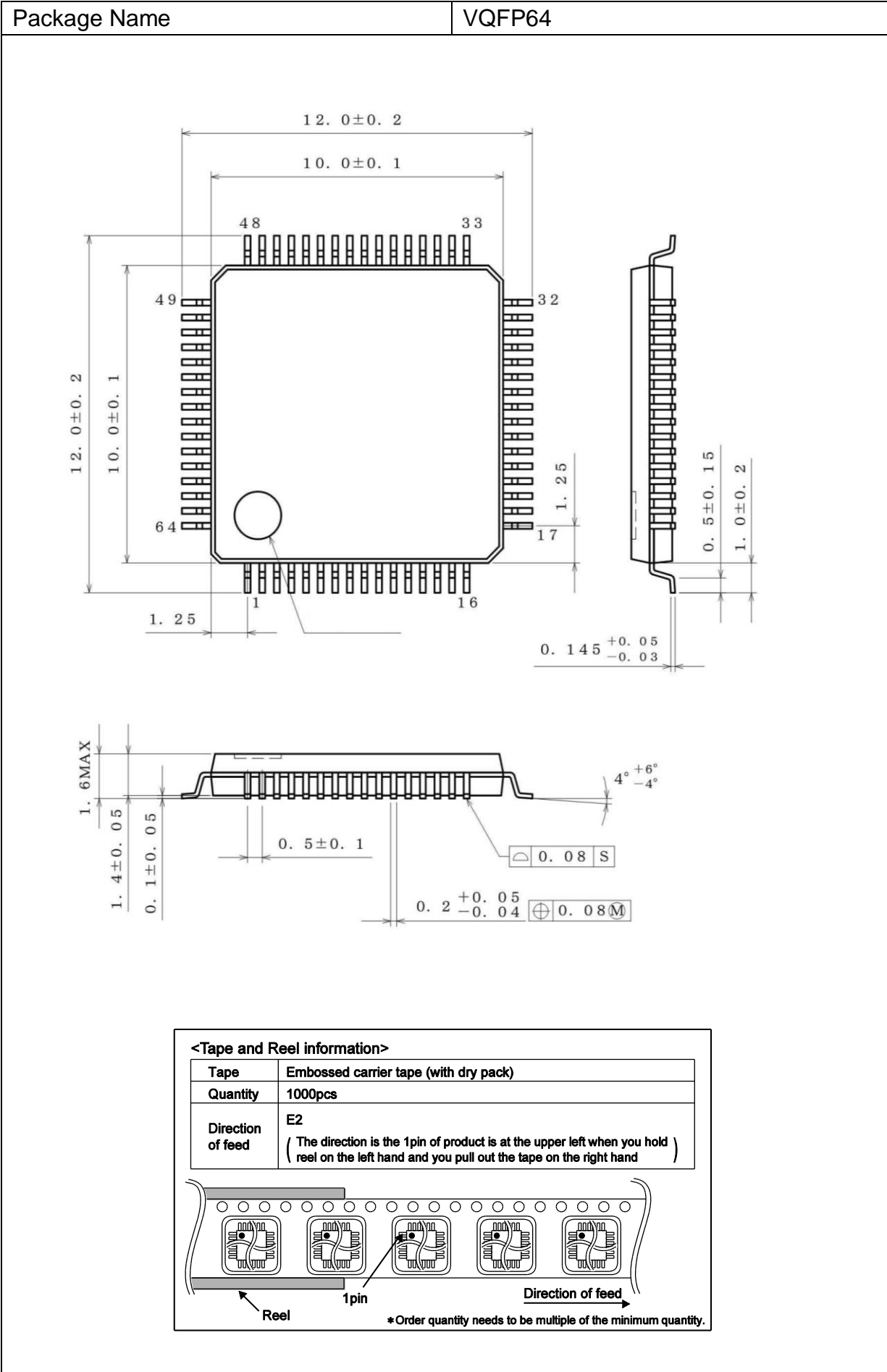

## Revision History

Version	date	description
001	07. Aug. 2013	1 <sup>st</sup> ver
002	07. Nov. 2013	Page.4 Add Electrical Characteristics of External Clock Frequency
003	31. Jan. 2014	<p>Page.2 Modify Pin Description OSC, DO, RESB, VSS and S1/P1 to S4/P4 Functions</p> <p>Page.3 Modify Absolute Maximum Ratings Power Dissipation</p> <p>Page.3 Modify Electrical Characteristics precondition</p> <p>Page.3 Modify Electrical Characteristics LCD Bias Voltage VMID1 Conditions</p> <p>Page.4 Modify Electrical Characteristics External Clock Frequency Symbol</p> <p>Page.4 Add Typical temperature characteristics VDD condition</p> <p>Page.4 Modify MPU Interface Characteristics tCHW Parameter name</p> <p>Page.4 Modify Figure 5 Title</p> <p>Page.5 Modify I/O equivalent circuit</p> <p>Page.5-6 Modify Command and Data Transfer Method description</p> <p>Page.6 Modify Command Transfer Method description</p> <p>Page.6 Modify Display Data Transfer Method description</p> <p>Page.10 Modify Serial Data Output description</p> <p>Page.10 Modify Output Data description</p> <p>Page.11-12 Modify Key Scan Operation description</p> <p>Page.14-17 Modify LCD Driver Bias/Duty Circuit figure</p> <p>Page.18 Modify Table name</p> <p>Page.19 Minor translation change Sleep Control command description to have more conformity between Japanese and English version</p> <p>Page.19 Minor translation change Segment Control command description to have more conformity between Japanese and English version</p> <p>Page.20 Minor translation change Drive Control1 command description to have more conformity between Japanese and English version</p> <p>Page.20 Minor translation change Drive Control2 command description to have more conformity between Japanese and English version</p> <p>Page.21 Add Drive Control3 command description</p> <p>Page.21 Minor translation change Drive Control3 command description to have more conformity between Japanese and English version</p> <p>Page.22 Minor translation change Software command description to have more conformity between Japanese and English version</p> <p>Page.22 Delete Address Set command description</p> <p>Page.22 Minor translation change Address command description to have more conformity between Japanese and English version</p> <p>Page.22 Modify Data Write command description</p> <p>Page.23 Add Initialize sequence Note14, Note15</p> <p>Page.29 Add Physical Dimension, Tape and Reel Information description</p>
004	11. Apr. 2014	<p>Page.11 Add f<sub>OSC</sub> explanation when External clock input</p> <p>Page.12 Add f<sub>OSC</sub> explanation when External clock input</p> <p>Page.24 Add the condition when power up and power down</p>
005	20. Jan. 2015	Page.24 Add the condition when power up and power down
006	12. Feb. 2019	<p>Page.2 Modify "I/O" of OSC in Pin Description.</p> <p>Page.2 Separate "I/O" and "Handling when unused" of K11/S48 to K15/S52 to input terminal and output terminal from input and output terminal in Pin Description.</p> <p>Page.3 Delete temperature condition in Absolute Maximum Ratings.</p> <p>Page.3 Move Operational Temperature Range to Recommended Operating Conditions</p> <p>Page.3 Add Caution 2 in Absolute Maximum Ratings. (Transcription from Thermal Consideration in Operational Notes)</p> <p>Page.4 Add "External Clock Rise Time", "External Clock Fall Time" and "External Clock Duty" in Oscillation Characteristics.</p> <p>Page.5 Add descriptions in MPU Interface Characteristics.</p> <p>Page.21 Add External Clock input timing function in Drive Control1 (DRV CTRL1)</p> <p>Page.22 Add descriptions in Drive Control2 (DRV CTRL2).</p> <p>Page.25 Add descriptions in Power Up Sequence and Power Down Sequence.</p> <p>Page.26 Add Display off Operation in External Clock Mode.</p> <p>Page.28 Delete Thermal Consideration (Move to Absolute Maximum Ratings)</p>



# Notice

## Precaution on using ROHM Products

- Our Products are designed and manufactured for application in ordinary electronic equipment (such as AV equipment, OA equipment, telecommunication equipment, home electronic appliances, amusement equipment, etc.). If you intend to use our Products in devices requiring extremely high reliability (such as medical equipment <sup>(Note 1)</sup>, transport equipment, traffic equipment, aircraft/spacecraft, nuclear power controllers, fuel controllers, car equipment including car accessories, safety devices, etc.) and whose malfunction or failure may cause loss of human life, bodily injury or serious damage to property ("Specific Applications"), please consult with the ROHM sales representative in advance. Unless otherwise agreed in writing by ROHM in advance, ROHM shall not be in any way responsible or liable for any damages, expenses or losses incurred by you or third parties arising from the use of any ROHM's Products for Specific Applications.

(Note1) Medical Equipment Classification of the Specific Applications

JAPAN	USA	EU	CHINA
CLASS III	CLASS III	CLASS II b	CLASS III
CLASS IV		CLASS III	

- ROHM designs and manufactures its Products subject to strict quality control system. However, semiconductor products can fail or malfunction at a certain rate. Please be sure to implement, at your own responsibilities, adequate safety measures including but not limited to fail-safe design against the physical injury, damage to any property, which a failure or malfunction of our Products may cause. The following are examples of safety measures:
  - Installation of protection circuits or other protective devices to improve system safety
  - Installation of redundant circuits to reduce the impact of single or multiple circuit failure
- Our Products are designed and manufactured for use under standard conditions and not under any special or extraordinary environments or conditions, as exemplified below. Accordingly, ROHM shall not be in any way responsible or liable for any damages, expenses or losses arising from the use of any ROHM's Products under any special or extraordinary environments or conditions. If you intend to use our Products under any special or extraordinary environments or conditions (as exemplified below), your independent verification and confirmation of product performance, reliability, etc. prior to use, must be necessary:
  - Use of our Products in any types of liquid, including water, oils, chemicals, and organic solvents
  - Use of our Products outdoors or in places where the Products are exposed to direct sunlight or dust
  - Use of our Products in places where the Products are exposed to sea wind or corrosive gases, including Cl<sub>2</sub>, H<sub>2</sub>S, NH<sub>3</sub>, SO<sub>2</sub>, and NO<sub>2</sub>
  - Use of our Products in places where the Products are exposed to static electricity or electromagnetic waves
  - Use of our Products in proximity to heat-producing components, plastic cords, or other flammable items
  - Sealing or coating our Products with resin or other coating materials
  - Use of our Products without cleaning residue of flux (Exclude cases where no-clean type fluxes is used. However, recommend sufficiently about the residue.) ; or Washing our Products by using water or water-soluble cleaning agents for cleaning residue after soldering
  - Use of the Products in places subject to dew condensation
- The Products are not subject to radiation-proof design.
- Please verify and confirm characteristics of the final or mounted products in using the Products.
- In particular, if a transient load (a large amount of load applied in a short period of time, such as pulse, is applied, confirmation of performance characteristics after on-board mounting is strongly recommended. Avoid applying power exceeding normal rated power; exceeding the power rating under steady-state loading condition may negatively affect product performance and reliability.
- De-rate Power Dissipation depending on ambient temperature. When used in sealed area, confirm that it is the use in the range that does not exceed the maximum junction temperature.
- Confirm that operation temperature is within the specified range described in the product specification.
- ROHM shall not be in any way responsible or liable for failure induced under deviant condition from what is defined in this document.

## Precaution for Mounting / Circuit board design

- When a highly active halogenous (chlorine, bromine, etc.) flux is used, the residue of flux may negatively affect product performance and reliability.
- In principle, the reflow soldering method must be used on a surface-mount products, the flow soldering method must be used on a through hole mount products. If the flow soldering method is preferred on a surface-mount products, please consult with the ROHM representative in advance.

For details, please refer to ROHM Mounting specification

### Precautions Regarding Application Examples and External Circuits

1. If change is made to the constant of an external circuit, please allow a sufficient margin considering variations of the characteristics of the Products and external components, including transient characteristics, as well as static characteristics.
2. You agree that application notes, reference designs, and associated data and information contained in this document are presented only as guidance for Products use. Therefore, in case you use such information, you are solely responsible for it and you must exercise your own independent verification and judgment in the use of such information contained in this document. ROHM shall not be in any way responsible or liable for any damages, expenses or losses incurred by you or third parties arising from the use of such information.

### Precaution for Electrostatic

This Product is electrostatic sensitive product, which may be damaged due to electrostatic discharge. Please take proper caution in your manufacturing process and storage so that voltage exceeding the Products maximum rating will not be applied to Products. Please take special care under dry condition (e.g. Grounding of human body / equipment / solder iron, isolation from charged objects, setting of Ionizer, friction prevention and temperature / humidity control).

### Precaution for Storage / Transportation

1. Product performance and soldered connections may deteriorate if the Products are stored in the places where:
  - [a] the Products are exposed to sea winds or corrosive gases, including Cl<sub>2</sub>, H<sub>2</sub>S, NH<sub>3</sub>, SO<sub>2</sub>, and NO<sub>2</sub>
  - [b] the temperature or humidity exceeds those recommended by ROHM
  - [c] the Products are exposed to direct sunshine or condensation
  - [d] the Products are exposed to high Electrostatic
2. Even under ROHM recommended storage condition, solderability of products out of recommended storage time period may be degraded. It is strongly recommended to confirm solderability before using Products of which storage time is exceeding the recommended storage time period.
3. Store / transport cartons in the correct direction, which is indicated on a carton with a symbol. Otherwise bent leads may occur due to excessive stress applied when dropping of a carton.
4. Use Products within the specified time after opening a humidity barrier bag. Baking is required before using Products of which storage time is exceeding the recommended storage time period.

### Precaution for Product Label

A two-dimensional barcode printed on ROHM Products label is for ROHM's internal use only.

### Precaution for Disposition

When disposing Products please dispose them properly using an authorized industry waste company.

### Precaution for Foreign Exchange and Foreign Trade act

Since concerned goods might be fallen under listed items of export control prescribed by Foreign exchange and Foreign trade act, please consult with ROHM in case of export.

### Precaution Regarding Intellectual Property Rights

1. All information and data including but not limited to application example contained in this document is for reference only. ROHM does not warrant that foregoing information or data will not infringe any intellectual property rights or any other rights of any third party regarding such information or data.
2. ROHM shall not have any obligations where the claims, actions or demands arising from the combination of the Products with other articles such as components, circuits, systems or external equipment (including software).
3. No license, expressly or implied, is granted hereby under any intellectual property rights or other rights of ROHM or any third parties with respect to the Products or the information contained in this document. Provided, however, that ROHM will not assert its intellectual property rights or other rights against you or your customers to the extent necessary to manufacture or sell products containing the Products, subject to the terms and conditions herein.

### Other Precaution

1. This document may not be reprinted or reproduced, in whole or in part, without prior written consent of ROHM.
2. The Products may not be disassembled, converted, modified, reproduced or otherwise changed without prior written consent of ROHM.
3. In no event shall you use in any way whatsoever the Products and the related technical information contained in the Products or this document for any military purposes, including but not limited to, the development of mass-destruction weapons.
4. The proper names of companies or products described in this document are trademarks or registered trademarks of ROHM, its affiliated companies or third parties.

**General Precaution**

1. Before you use our Products, you are requested to carefully read this document and fully understand its contents. ROHM shall not be in any way responsible or liable for failure, malfunction or accident arising from the use of any ROHM's Products against warning, caution or note contained in this document.
2. All information contained in this document is current as of the issuing date and subject to change without any prior notice. Before purchasing or using ROHM's Products, please confirm the latest information with a ROHM sales representative.
3. The information contained in this document is provided on an "as is" basis and ROHM does not warrant that all information contained in this document is accurate and/or error-free. ROHM shall not be in any way responsible or liable for any damages, expenses or losses incurred by you or third parties resulting from inaccuracy or errors of or concerning such information.