



Dual Supply / Low Power / 1024-tap / 2-Wire bus

# X9118

## Single Digitally-Controlled (XDCP™) Potentiometer

### FEATURES

- 1024 Resistor Taps – 10-Bit Resolution
- 2-Wire Serial Interface for write, read, and transfer operations of the potentiometer
- Wiper Resistance, 40Ω Typical @ 5V
- Four Non-Volatile Data Registers for Each Potentiometer
- Non-Volatile Storage of Multiple Wiper Positions
- Power On Recall. Loads Saved Wiper Position on Power Up.
- Standby Current < 3μA Max
- System V<sub>CC</sub>: - 2.7V to 5.5V Operation
- Analog V<sub>+</sub>/V<sub>-</sub>: -5V to +5V
- 100KΩ End to End Resistance
- Endurance: 100, 000 Data changes per bit per register
- 100 yr. Data Retention
- 14-Lead TSSOP, 15-Lead CSP (Chip Scale Package). Call factory for CSP availability
- Low power CMOS

### DESCRIPTION

The X9118 integrates a single digitally controlled potentiometer (XDCP) on a monolithic CMOS integrated circuit.

The digital controlled potentiometer is implemented using 1023 resistive elements in a series array. Between each element are tap points connected to the wiper terminal through switches. The position of the wiper on the array is controlled by the user through the 2-wire bus interface. The potentiometer has associated with it a volatile Wiper Counter Register (WCR) and a four non-volatile Data Registers that can be directly written to and read by the user. The contents of the WCR controls the position of the wiper on the resistor array through the switches. Powerup recalls the contents of the default data register (DR0) to the WCR.

The XDCP can be used as a three-terminal potentiometer or as a two terminal variable resistor in a wide variety of applications including control, parameter adjustments, and signal processing.

### FUNCTIONAL DIAGRAM

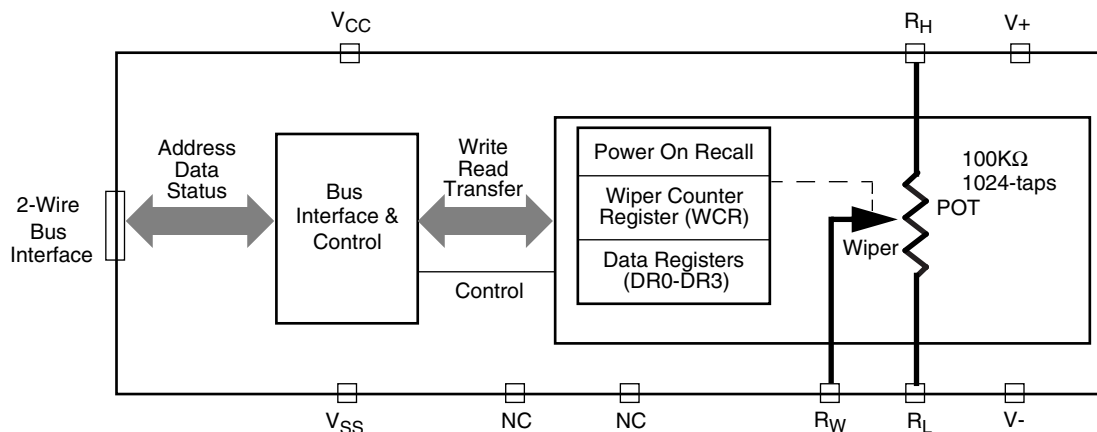

## DETAILED FUNCTIONAL DIAGRAM

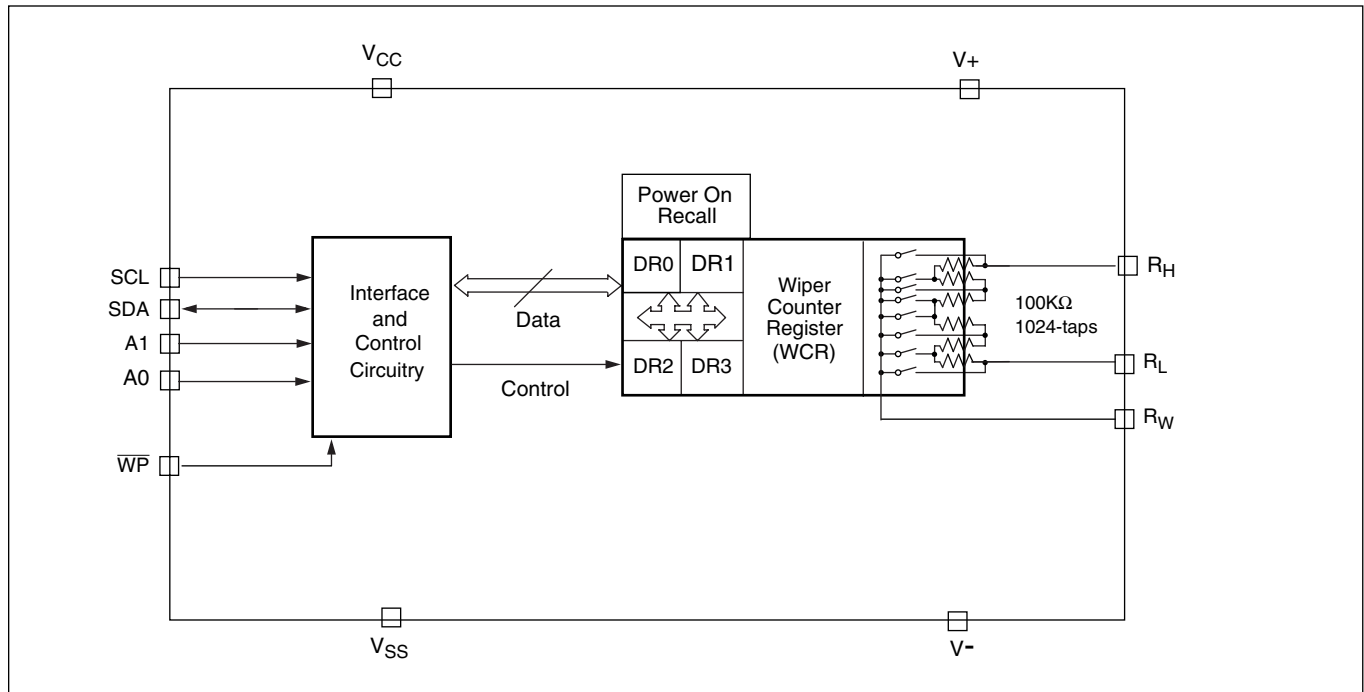

### CIRCUIT LEVEL APPLICATIONS

- Vary the gain of a voltage amplifier
- Provide programmable dc reference voltages for comparators and detectors
- Control the volume in audio circuits
- Trim out the offset voltage error in a voltage amplifier circuit
- Set the output voltage of a voltage regulator
- Trim the resistance in Wheatstone bridge circuits
- Control the gain, characteristic frequency and Q-factor in filter circuits
- Set the scale factor and zero point in sensor signal conditioning circuits
- Vary the frequency and duty cycle of timer ICs
- Vary the dc biasing of a pin diode attenuator in RF circuits
- Provide a control variable (I, V, or R) in feedback circuits

### SYSTEM LEVEL APPLICATIONS

- Adjust the contrast in LCD displays
- Control the power level of LED transmitters in communication systems
- Set and regulate the DC biasing point in an RF power amplifier in wireless systems
- Control the gain in audio and home entertainment systems
- Provide the variable DC bias for tuners in RF wireless systems
- Set the operating points in temperature control systems
- Control the operating point for sensors in industrial systems
- Trim offset and gain errors in artificial intelligent systems

# X9118

## PIN CONFIGURATION

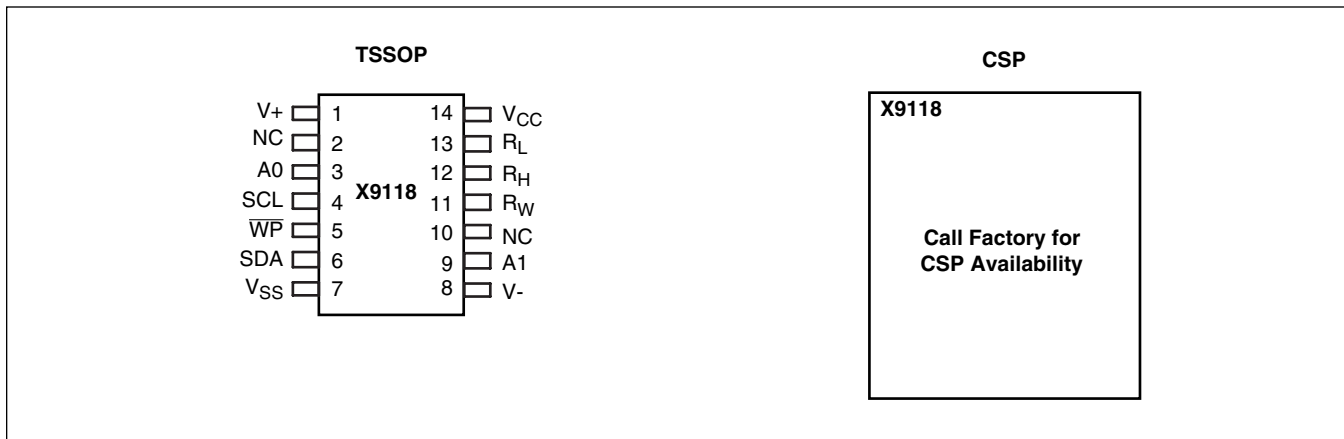

## PIN ASSIGNMENTS

Pin (TSSOP)	Pin (CSP)	Symbol	Function
1		V+	Analog Supply Voltage
2		NC	No Connect
3		A0	Device Address for 2-wire bus
4		SCL	Serial Clock for 2-wire bus
5		WP	Hardware Write Protect
6		SDA	Serial Data Input/Output for 2-wire bus
7		V <sub>SS</sub>	System Ground
8		V-	Analog Supply Voltage
9		A1	Device Address for 2-wire bus
10		NC	No Connect
11		R <sub>W</sub>	Wiper terminal of the Potentiometer
12		R <sub>H</sub>	High terminal of the Potentiometer
13		R <sub>L</sub>	Low terminal of the Potentiometer
14		V <sub>CC</sub>	System Supply Voltage

# X9118

---

## PIN DESCRIPTIONS

### Bus Interface Pins

#### SERIAL DATA INPUT/OUTPUT (SDA)

The SDA is a bidirectional serial data input/output pin for a 2-wire slave device and is used to transfer data into and out of the device. It receives device address, opcode, wiper register address and data sent from an 2-wire master at the rising edge of the serial clock SCL, and it shifts out data after each falling edge of the serial clock SCL.

It is an open drain output and may be wire-ORed with any number of open drain or open collector outputs. An open drain output requires the use of a pull-up resistor. For selecting typical values, refer to the guidelines for calculating typical values on the bus pull-up resistors graph.

#### SERIAL CLOCK (SCL)

This input is used by 2-wire master to supply 2-wire serial clock to the X9118.

#### DEVICE ADDRESS (A1–A0)

The address inputs are used to set the least significant 2 bits of the 8-bit slave address. A match in the slave address serial data stream must be made with the Address input in order to initiate communication with the X9118. A maximum of 4 XDCP devices may occupy the 2-wire serial bus.

#### HARDWARE WRITE PROTECT INPUT ( $\overline{WP}$ )

The  $\overline{WP}$  pin when LOW prevents nonvolatile writes to the Data Registers.

### Potentiometer Pins

#### $R_H$ , $R_L$

The  $R_H$  and  $R_L$  pins are equivalent to the terminal connections on a mechanical potentiometer.

#### $R_W$

The wiper pin is equivalent to the wiper terminal of a mechanical potentiometer.

### Bias Supply Pins

#### SYSTEM SUPPLY VOLTAGE ( $V_{CC}$ ) AND SUPPLY GROUND ( $V_{SS}$ )

The  $V_{CC}$  pin is the system or digital supply voltage. The  $V_{SS}$  pin is the system ground.

#### ANALOG SUPPLY VOLTAGES ( $V_+$ AND $V_-$ )

These supplies are the analog voltage supplies for the potentiometer. The  $V_+$  supply is tied to the wiper switches while the  $V_-$  supply is used to bias the switches and the internal P+ substrate of the integrated circuit. Both of these supplies set the voltage limits of the potentiometer.

### Other Pins

#### No CONNECT

No connect pins should be left open. These pins are used for Xicor manufacturing and testing purposes.

## PRINCIPLES OF OPERATION

The X9118 is an integrated microcircuit incorporating a resistor array and their its registers and counters and the serial interface logic providing direct communication between the host and the digitally controlled potentiometer. This section provides detail description of the following:

- Resistor Array Description
- Serial Interface Description
- Instruction and Register Description

### Resistor Array Description

The X9118 is comprised of a resistor array. The array contains 1023, in effect, discrete resistive segments that are connected in series (see Figure 1). The physical ends of each array are equivalent to the fixed terminals of a mechanical potentiometer ( $R_H$  and  $R_L$  inputs).

At both ends of each array and between each resistor segment is a CMOS switch (transmission gate) connected to the wiper ( $R_W$ ) output. Within each individual array only one switch may be turned on at a time. These switches are controlled by the Wiper Counter Register (WCR). The 10-bits of the WCR (WCR[9:0]) are decoded to select, and enable, one of 1024 switches.

The WCR may be written directly. The Data Registers and the WCR can be read and written by the host system.

# X9118

**Figure 1. Detailed Potentiometer Block Diagram**

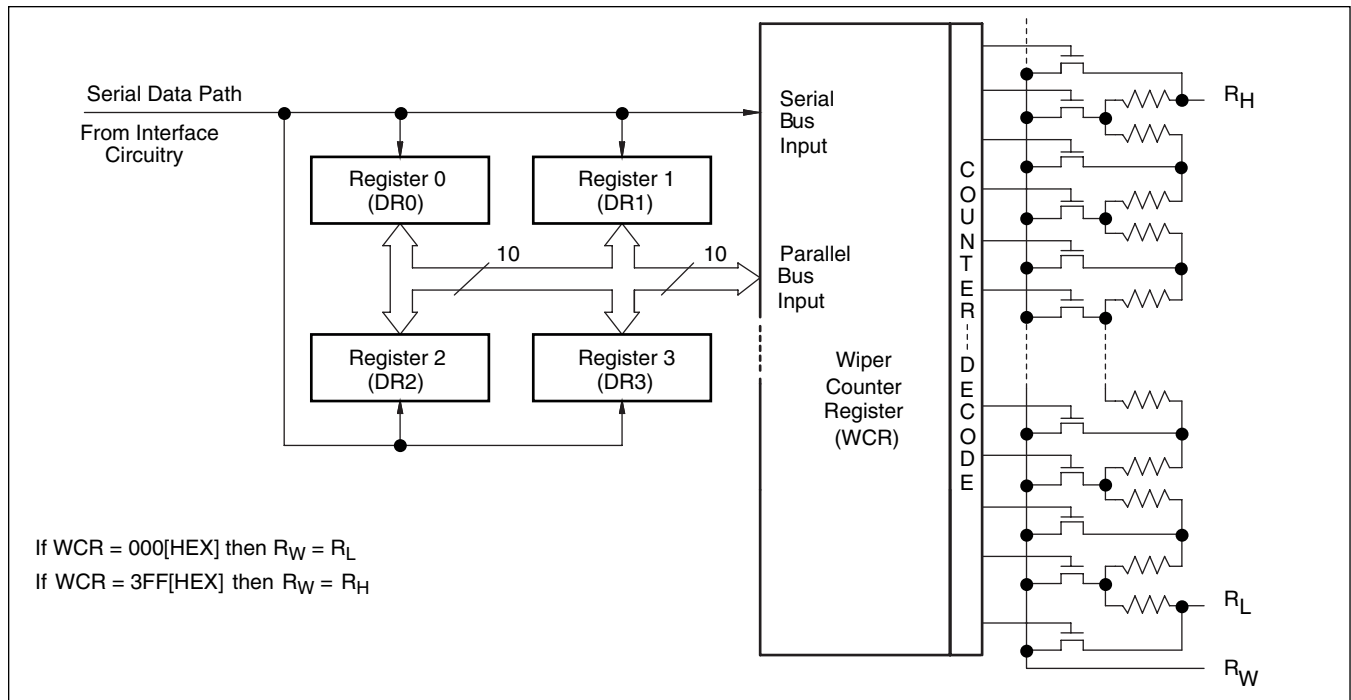

## Serial Interface Description

### SERIAL INTERFACE – 2-WIRE

The X9118 supports a bidirectional bus oriented protocol. The protocol defines any device that sends data onto the bus as a transmitter and the receiving device as the receiver. The device controlling the transfer is a master and the device being controlled is the slave. The master will always initiate data transfers and provide the clock for both transmit and receive operations. Therefore, the X9118 will be considered a slave device in all applications.

### CLOCK AND DATA CONVENTIONS

Data states on the SDA line can change only during SCL LOW periods. SDA state changes during SCL HIGH are reserved for indicating start and stop conditions. See Figure 3.

### START CONDITION

All commands to the X9118 are preceded by the start condition, which is a HIGH to LOW transition of SDA while SCL is HIGH. The X9118 continuously monitors the SDA and SCL lines for the start condition and will not respond to any command until this condition is met. See Figure 3.

### STOP CONDITION

All communications must be terminated by a stop condition, which is a LOW to HIGH transition of SDA while SCL is HIGH. See Figure 3.

### ACKNOWLEDGE

Acknowledge is a software convention used to provide a positive handshake between the master and slave devices on the bus to indicate the successful receipt of data. The transmitting device, either the master or the slave, will release the SDA bus after transmitting eight bits. The master generates a ninth clock cycle and during this period the receiver pulls the SDA line LOW to acknowledge that it successfully received the eight bits of data.

The X9118 will respond with an acknowledge after recognition of a start condition and its slave address and once again after successful receipt of the command byte. If the command is followed by a data byte the X9118 will respond with a final acknowledge. See Figure 2.

**Figure 2. Acknowledge Response from Receiver**

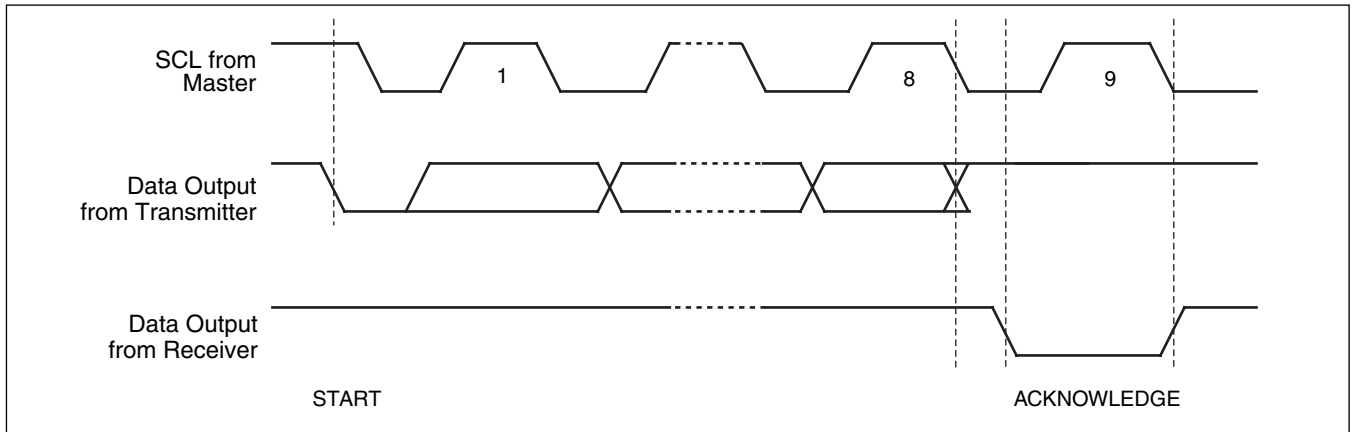

**ACKNOWLEDGE POLLING**

The disabling of the inputs, during the internal nonvolatile write operation, can be used to take advantage of the typical 5ms EEPROM write cycle time. Once the stop condition is issued to indicate the end of the nonvolatile write command the X9118 initiates the internal write cycle. ACK polling, Flow 1, can be initiated immediately. This involves issuing the start condition followed by the device slave address. If the X9118 is still busy with the write operation no ACK will be returned. If the X9118 has completed the write operation an ACK will be returned and the master can then proceed with the next operation.

**FLOW 1. ACK Polling Sequence**

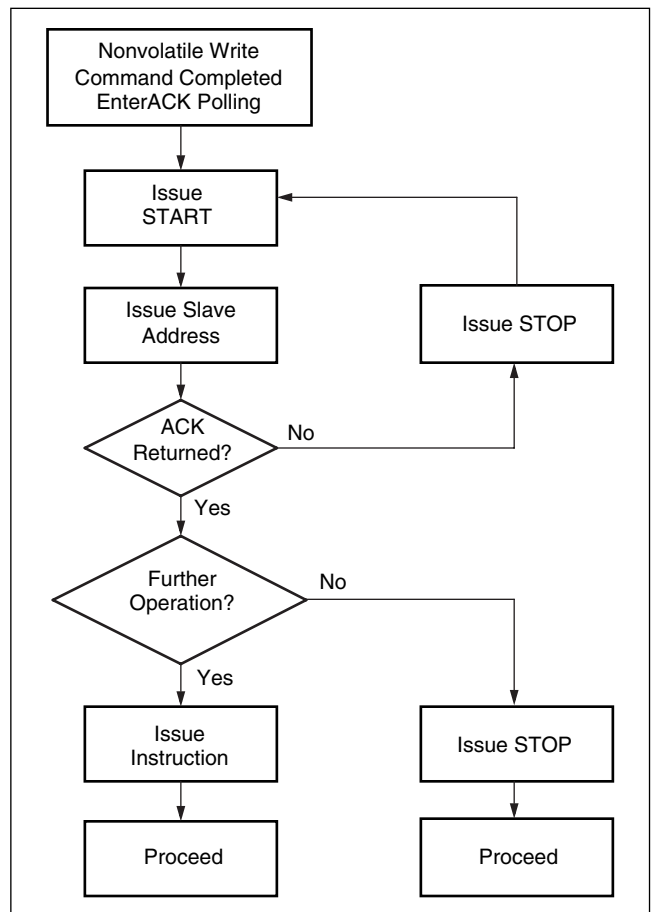

# X9118

## Instruction and Register Description

### DEVICE ADDRESSING: IDENTIFICATION BYTE (ID AND A)

Following a start condition the master must output the address of the slave it is accessing. The most significant four bits of the slave address are the device type identifier. The ID[3:0] bits is the device id for the X9118; this is fixed as 0101[B] (refer to Table 1).

The A[1:0] bits in the ID byte are the internal slave address. The physical device address is defined by the state of the A1-A0 input pins. The slave address is externally specified by the user. The X9118 compares the serial data stream with the address input state; a successful compare of both address bits is required for the X9118 to successfully continue the command

sequence. Only the device which slave address matches the incoming device address sent by the master executes the instruction. The A1-A0 inputs can be actively driven by CMOS input signals or tied to  $V_{CC}$  or  $V_{SS}$ . The  $R/\bar{W}$  bit is the LSB and is used to set the device for read or write operations.

### INSTRUCTION BYTE AND REGISTER SELECTION

The next byte sent to the X9118 contains the instruction and register pointer information. The three most significant bits are used provide the instruction opcode (I[2:0]). The RB and RA bits point to one of the four registers. The format is shown below in Table 2.

Table 3 provides a complete summary of the instruction set opcodes.

**Table 1. Identification Byte Format**

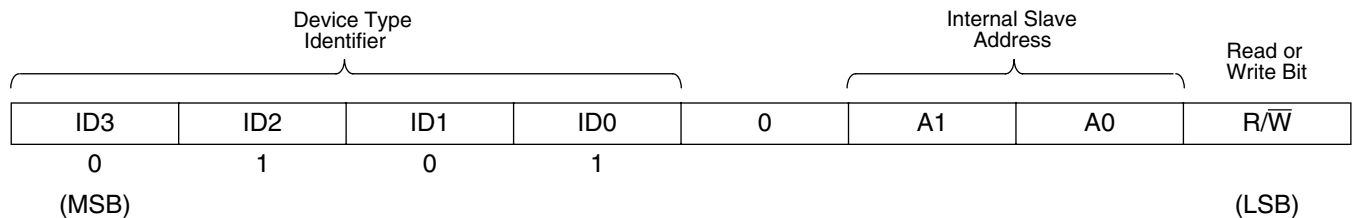

**Table 2. Instruction Byte Format**

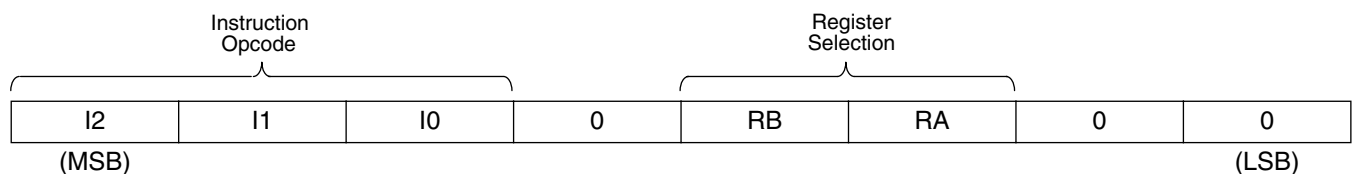

Register Selected	RB	RA
DR0	0	0
DR1	0	1
DR2	1	0
DR3	1	1

# X9118

**Table 3. Instruction Set**

Instruction	Instruction Set									Operation
	R/W	I <sub>2</sub>	I <sub>1</sub>	I <sub>0</sub>	0	RB	RA	0	0	
Read Wiper Counter Register	1	1	0	0	0	0	0	0	0	Read the contents of the Wiper Counter Register
Write Wiper Counter Register	0	1	0	1	0	0	0	0	0	Write new value to the Wiper Counter Register
Read Data Register	1	1	0	1	0	1/0	1/0	0	0	Read the contents of the Data Register pointed to RB-RA.
Write Data Register	0	1	1	0	0	1/0	1/0	0	0	Write new value to the Data Register pointed to RB-RA.
XFR Data Register to Wiper Counter Register	1	1	1	0	0	1/0	1/0	0	0	Transfer the contents of the Data Register pointed to by RB-RA to the Wiper Counter Register
XFR Wiper Counter Register to Data Register	0	1	1	1	0	1/0	1/0	0	0	Transfer the contents of the Wiper Counter Register to the Data Register pointed to by RB-RA.

**Note:** (1) 1/0 = data is one or zero.

## Instruction and Register Description

### DEVICE ADDRESSING

### WIPER COUNTER REGISTER (WCR)

The X9118 contains a Wiper Counter Register (see Table 4) for the XDCP potentiometer. The WCR is equivalent to a serial-in, parallel-out register/counter with its outputs decoded to select one of 1024 switches along its resistor array. The contents of the WCR can be altered in one of three ways: (1) it may be written directly by the host via the write Wiper Counter Register instruction (serial load); (2) it may be written indirectly by transferring the contents of one of four associated Data Registers via the XFR Data register; (3) it is loaded with the contents of its Data Register zero (R0) upon power-up.

The Wiper Counter Register is a volatile register; that is, its contents are lost when the X9118 is powered-down. Although the register is automatically loaded

with the value in DR0 upon power-up, this may be different from the value present at power-down. Power-up guidelines are recommended to ensure proper loadings of the DR0 value into the WCR .

### DATA REGISTERS (DR)

The potentiometer has four 10-bit non-volatile Data Registers. These can be read or written directly by the host. Data can also be transferred between any of the four data registers and the Wiper Counter Register. All operations changing data in one of the Data Registers is a nonvolatile operation and will take a maximum of 10ms.

If the application does not require storage of multiple settings for the potentiometer, the Data Registers can be used as regular memory locations for system parameters or user preference data.

Bit 9–Bit 0 are used to store one of the 1024 wiper position (0 ~1023).



# X9118

**Table 4. Wiper Control Register, WCR (10-bit), WCR9–WCR0:** Used to store the current wiper position (Volatile, V)

WCR9	WCR8	WCR7	WCR6	WCR5	WCR4	WCR3	WCR2	WCR1	WCR0
V	V	V	V	V	V	V	V	V	V
(MSB)					(LSB)				

**Table 5. Data Register, DR (10-bit), Bit 9–Bit 0:** Used to store wiper positions or data (Non-Volatile, NV)

Bit 9	Bit 8	Bit 7	Bit 6	Bit 5	Bit 4	Bit 3	Bit 2	Bit 1	Bit 0
NV	NV	NV	NV	NV	NV	NV	NV	NV	NV
MSB					LSB				

Four of the six instructions are four bytes in length. These instructions are:

- **Read Wiper Counter Register** – read the current wiper position of the potentiometer,
- **Write Wiper Counter Register** – change current wiper position of the potentiometer,
- **Read Data Register** – read the contents of the selected Data Register;
- **Write Data Register** – write a new value to the selected Data Register.

The basic sequence of the four byte instructions is illustrated in Figure 3. These four-byte instructions exchange data between the WCR and one of the Data Registers. A transfer from a data register to a WCR is essentially a write to a static RAM, with the static RAM controlling the wiper position. The response of the wiper to this action will be delayed by  $t_{WR_L}$ . A transfer from the WCR (current wiper position), to a data register is a write to nonvolatile memory and takes a minimum of  $t_{WR}$  to complete. The transfer can occur between the potentiometer and one of its associated registers.

Two instructions (see Figure 4) require a two-byte sequence to complete. These instructions transfer data between the host and the X9118; either between the host and one of the Data Registers or directly between the host and the Wiper Counter Register. These instructions are:

- **XFR Data Register to Wiper Counter Register** – This transfers the contents of one specified Data Register to the Wiper Counter Register.
- **XFR Wiper Counter Register to Data Register** – This transfers the contents of the specified Wiper Counter Register to the specified Data Register.

See Instruction format for more details.

## Other

### POWER UP AND DOWN REQUIREMENTS

At all times, the  $V_+$  voltage must be greater than or equal to the voltage at  $R_H$  or  $R_L$ , and the voltage at  $R_H$  or  $R_L$  must be greater than or equal to the voltage at  $V_-$ . During power up and power down,  $V_{CC}$ ,  $V_+$ , and  $V_-$  must reach their final values with 1msec of each other.

**Figure 3. Two-Byte Instruction Sequence**

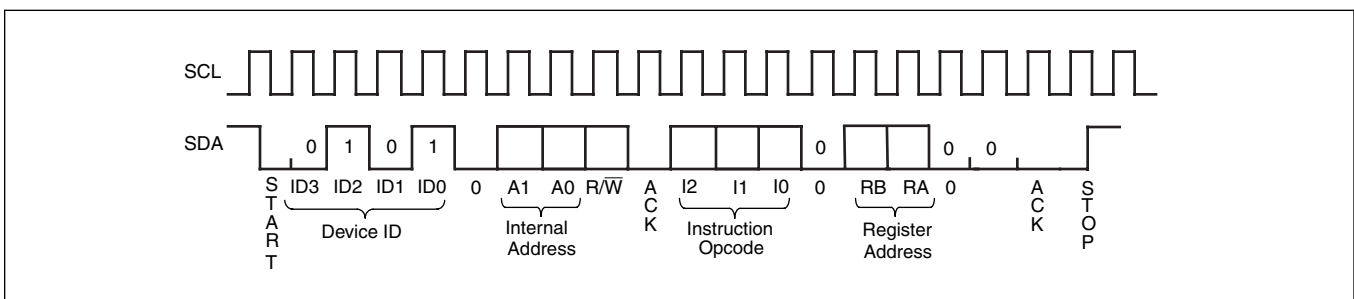
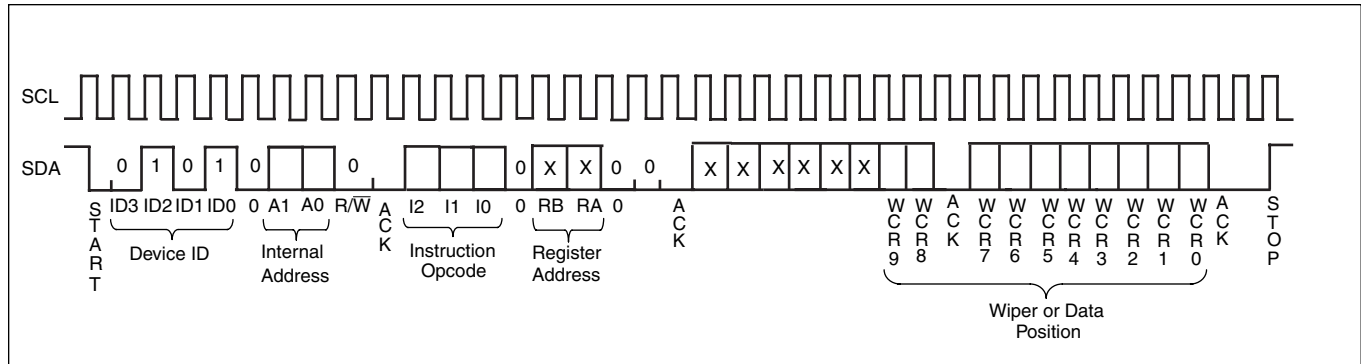

Figure 4. Four-Byte Instruction Sequence (Write or Read for WCR or Data Registers)



**INSTRUCTION FORMAT**

**Read Wiper Counter Register (WCR)**

START	Device Type Identifier				Device Addresses			S A C K	Instruction Opcode				Register Addresses				S A C K	Wiper Position (Sent by Slave on SDA)								M A C K	S T O P							
	0	1	0	1	0	A1	A0		R/W=1	1	0	0	0	0	0	0		0	X	X	X	X	X	X	W C R 9			W C R 8	W C R 7	W C R 6	W C R 5	W C R 4	W C R 3	W C R 2
	0	1	0	1	0	A1	A0	R/W=1	1	0	0	0	0	0	0	0	X	X	X	X	X	X	W C R 9	W C R 8	W C R 7	W C R 6	W C R 5	W C R 4	W C R 3	W C R 2	W C R 1	W C R 0		

**Write Wiper Counter Register (WCR)**

START	Device Type Identifier				Device Addresses			S A C K	Instruction Opcode				Register Addresses				S A C K	Wiper Position (Sent by Master on SDA)								S A C K	S T O P							
	0	1	0	1	0	A1	A0		R/W=0	1	0	1	0	0	0	0		0	X	X	X	X	X	X <th>W C R 9</th> <th>W C R 8</th> <th>W C R 7</th> <th>W C R 6</th> <th>W C R 5</th> <th>W C R 4</th> <th>W C R 3</th> <th>W C R 2</th> <th>W C R 1</th> <th>W C R 0</th>	W C R 9			W C R 8	W C R 7	W C R 6	W C R 5	W C R 4	W C R 3	W C R 2
	0	1	0	1	0	A1	A0	R/W=0	1	0	1	0	0	0	0	0	X	X	X	X	X	X	W C R 9	W C R 8	W C R 7	W C R 6	W C R 5	W C R 4	W C R 3	W C R 2	W C R 1	W C R 0		

**Read Data Register (DR)**

START	Device Type Identifier				Device Addresses			S A C K	Instruction Opcode				Register Addresses				S A C K	Wiper Position (Sent by Slave on SDA)								M A C K	S T O P							
	0	1	0	1	0	A1	A0		R/W=1	1	0	1	0	RB	RA	0		0	X	X	X	X	X	X <th>W C R 9</th> <th>W C R 8</th> <th>W C R 7</th> <th>W C R 6</th> <th>W C R 5</th> <th>W C R 4</th> <th>W C R 3</th> <th>W C R 2</th> <th>W C R 1</th> <th>W C R 0</th>	W C R 9			W C R 8	W C R 7	W C R 6	W C R 5	W C R 4	W C R 3	W C R 2
	0	1	0	1	0	A1	A0	R/W=1	1	0	1	0	RB	RA	0	0	X	X	X	X	X	X	W C R 9	W C R 8	W C R 7	W C R 6	W C R 5	W C R 4	W C R 3	W C R 2	W C R 1	W C R 0		

# X9118

## Write Data Register (DR)

START	Device Type Identifier				Device Addresses				SACK	Instruction Opcode				Register Addresses				SACK	Wiper Position or Data (Sent by Master on SDA)								SACK	STOP	HIGH-VOLTAGE WRITE CYCLE						
	0	1	0	1	0	A1	A0	R/W=0		1	1	0	0	RB	RA	0	0		X	X	X	X	X	X	WCR9	WCR8				WCR7	WCR6	WCR5	WCR4	WCR3	WCR2
	0	1	0	1	0	A1	A0	R/W=0	1	1	0	0	RB	RA	0	0	X	X	X	X	X	X	WCR9	WCR8	WCR7	WCR6	WCR5	WCR4	WCR3	WCR2	WCR1	WCR0			

## Transfer Wiper Counter Register (WCR) to Data Register (DR)

START	Device Type Identifier				Device Addresses				SACK	Instruction Opcode				Register Addresses				SACK	STOP	HIGH-VOLTAGE WRITE CYCLE															
	0	1	0	1	0	A1	A0	R/W=0		1	1	1	0	RB	RA	0	0																		
	0	1	0	1	0	A1	A0	R/W=0	1	1	1	0	RB	RA	0	0																			

## Transfer Data Register (DR) to Wiper Counter Register (WCR)

START	Device Type Identifier				Device Addresses				SACK	Instruction Opcode				Register Addresses				SACK	STOP													
	0	1	0	1	0	A1	A0	R/W=1		1	1	0	0	RB	RA	0	0															
	0	1	0	1	0	A1	A0	R/W=1	1	1	0	0	RB	RA	0	0																

- Notes:** (1) "A1 ~ A0": stand for the device addresses sent by the master.  
 (2) WCRx refers to wiper position data in the Wiper Counter Register

# X9118

## ABSOLUTE MAXIMUM RATINGS

Temperature under bias..... -65°C to +135°C  
 Storage temperature..... -65°C to +150°C  
 Voltage on SCL, SDA, or any address input  
 with respect to  $V_{SS}$  ..... -1V to +7V  
 Voltage on V+ (referenced to  $V_{SS}$ )<sup>(4)</sup> ..... 10V  
 Voltage on V- (referenced to  $V_{SS}$ )<sup>(4)</sup> ..... -10V  
 (V+) – (V-) ..... 12V  
 Any Voltage on  $R_H$  /  $R_L$  ..... V+  
 Any Voltage on  $R_L$  /  $R_H$  ..... V-  
 Lead temperature (soldering, 10 seconds) ..... 300°C  
 $I_W$  (10 seconds) ..... ±6mA

## COMMENT

Stresses above those listed under “Absolute Maximum Ratings” may cause permanent damage to the device. This is a stress rating only; the functional operation of the device (at these or any other conditions above those listed in the operational sections of this specification) is not implied. Exposure to absolute maximum rating conditions for extended periods may affect device reliability.

## RECOMMENDED OPERATING CONDITIONS

Temp	Min.	Max.
Commercial	0°C	+70°C
Industrial	-40°C	+85°C

Device	Supply Voltage ( $V_{CC}$ ) Limits <sup>(4)</sup>
X9118	5V ±10%
X9118-2.7	2.7V to 5.5V

**ANALOG CHARACTERISTICS** (Over recommended industrial (2.7V) operation conditions unless otherwise stated.)

Symbol	Parameter	Limits				Test Conditions
		Min.	Typ.	Max.	Units	
$R_{TOTAL}$	End to End Resistance		100		k $\Omega$	
	End to End Resistance Tolerance			±20	%	
	Power Rating			50	mW	25°C, each pot
$I_W$	Wiper Current			±3	mA	
$R_W$	Wiper Resistance		150	500	$\Omega$	Wiper Current = ± 3mA, $V_{CC}$ = 3V
$R_W$	Wiper Resistance		40	100	$\Omega$	$I_W$ = ± 3mA, $V_{CC}$ = 5V
$V_{V+}$	Voltage on V+ pin	+4.5		+5.5	V	X9118 <sup>(4)</sup>
		+2.7		+5.5		X9118-2.7 <sup>(4)</sup>
$V_{V-}$	Voltage on V- pin	-5.5		-4.5	V	X9118
		-5.5		-2.7		X9118-2.7
$V_{TERM}$	Voltage on any $R_H$ or $R_L$ Pin	V-		V+	V	$V_{SS}$ = 0V
	Noise		-120		dBV	Ref: 1V
	Resolution		0.1		%	
	Absolute Linearity <sup>(1)</sup>			±1	MI <sup>(3)</sup>	$R_{W(n)(actual)} - R_{W(n)(expected)}$ , where n=8 to 1006
				±1.5	MI <sup>(3)</sup>	$R_{W(n)(actual)} - R_{W(n)(expected)}$ <sup>(5)</sup>
	Relative Linearity <sup>(2)</sup>			±0.5	MI <sup>(3)</sup>	$R_{W(m+1)} - [R_{W(m)} + MI]$ , where m=8 to 1006
				±1	MI <sup>(3)</sup>	$R_{W(m+1)} - [R_{W(m)} + MI]$ <sup>(5)</sup>
	Temperature Coefficient of $R_{TOTAL}$		±300		ppm/°C	
	Ratiometric Temp. Coefficient			20	ppm/°C	
$C_H/C_L/C_W$	Potentiometer Capacitancies		10/10/25		pF	See Macro model

# X9118

- Notes:** (1) Absolute linearity is utilized to determine actual wiper voltage versus expected voltage as determined by wiper position when used as a potentiometer.  
 (2) Relative linearity is utilized to determine the actual change in voltage between two successive tap positions when used as a potentiometer. It is a measure of the error in step size.  
 (3)  $MI = RTOT / 1023$  or  $(R_H - R_L) / 1023$ , single pot  
 (4)  $V_{CC}$ ,  $V+$ ,  $V-$  must reach their final values within 1 msec of each other.  
 (5)  $n = 0, 1, 2, \dots, 1023$ ;  $m = 0, 1, 2, \dots, 1022$ .

## D.C. OPERATING CHARACTERISTICS (Over the recommended operating conditions unless otherwise specified.)

Symbol	Parameter	Limits				Test Conditions
		Min.	Typ.	Max.	Units	
$I_{CC1}$	$V_{CC}$ supply current (active)			3	mA	$f_{SCL} = 400\text{KHz}$ ; $V_{CC} = +5.5\text{V}$ ; SDA = Open; (for 2-wire, Active, Read and Volatile Write States only)
$I_{CC2}$	$V_{CC}$ supply current (nonvolatile write)			5	mA	$f_{SCL} = 400\text{KHz}$ ; $V_{CC} = +5.5\text{V}$ ; SDA = Open; (for 2-wire, Active, Non-volatile Write State only)
$I_{SB}$	$V_{CC}$ current (standby)			3	$\mu\text{A}$	$V_{CC} = +5.5\text{V}$ ; $V_{IN} = V_{SS}$ or $V_{CC}$ ; SDA = $V_{CC}$ ; (for 2-wire, Standby State only)
$I_{LI}$	Input leakage current			10	$\mu\text{A}$	$V_{IN} = V_{SS}$ to $V_{CC}$
$I_{LO}$	Output leakage current			10	$\mu\text{A}$	$V_{OUT} = V_{SS}$ to $V_{CC}$
$V_{IH}$	Input HIGH voltage	$V_{CC} \times 0.7$		$V_{CC} + 1$	V	
$V_{IL}$	Input LOW voltage	-1		$V_{CC} \times 0.3$	V	
$V_{OL}$	Output LOW voltage			0.4	V	$I_{OL} = 3\text{mA}$
$V_{OH}$	Output HIGH voltage					

## ENDURANCE AND DATA RETENTION

Parameter	Min.	Units
Minimum Endurance	100,000	Data changes per bit per register
Data Retention	100	years

## CAPACITANCE

Symbol	Test	Max.	Units	Test Conditions
$C_{IN/OUT}^{(6)}$	Input/Output capacitance (SI)	8	pF	$V_{OUT} = 0\text{V}$
$C_{IN}^{(6)}$	Input capacitance (SCL, $\overline{WP}$ , A2, A1 and A0)	6	pF	$V_{IN} = 0\text{V}$

## POWER-UP TIMING

Symbol	Parameter	Min.	Max.	Units
$t_r V_{CC}^{(6)}$	$V_{CC}$ Power-up Rate	0.2	50	V/ms
$t_{PUR}^{(7)}$	Power-up to Initiation of read operation		1	ms
$t_{PUW}^{(7)}$	Power-up to Initiation of write operation		50	ms

**Notes:** (6) This parameter is not 100% tested

(7)  $t_{PUR}$  and  $t_{PUW}$  are the delays required from the time the (last) power supply ( $V_{CC}$ ) is stable until the specific instruction can be issued. These parameters are periodically sampled and not 100% tested.

# X9118

## A.C. TEST CONDITIONS

Input pulse levels	$V_{CC} \times 0.1$ to $V_{CC} \times 0.9$
Input rise and fall times	10ns
Input and output timing level	$V_{CC} \times 0.5$

## EQUIVALENT A.C. LOAD CIRCUIT

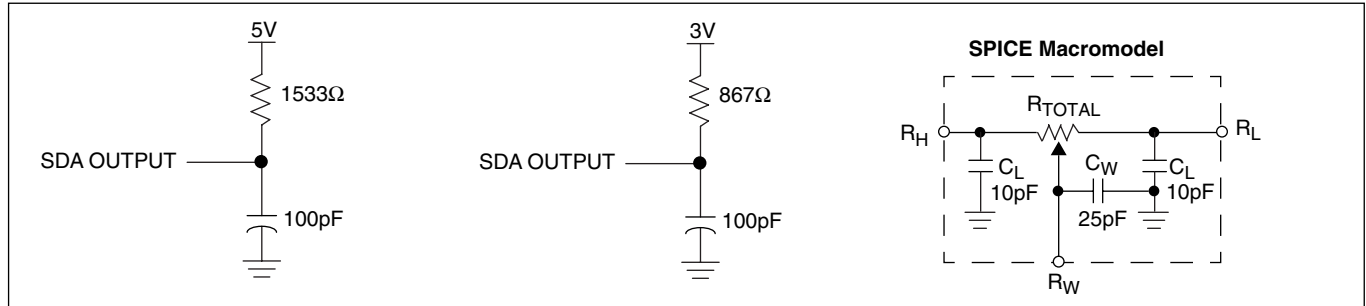

## AC TIMINGHIGH-VOLTAGE WRITE CYCLE TIMING

Symbol	Parameter	Min.	Max.	Units
$f_{SCL}$	Clock Frequency		400	kHz
$t_{CYC}$	Clock Cycle Time	2500		ns
$t_{HIGH}$	Clock High Time	600		ns
$t_{LOW}$	Clock Low Time	1300		ns
$t_{SU:STA}$	Start Setup Time	600		ns
$t_{HD:STA}$	Start Hold Time	600		ns
$t_{SU:STO}$	Stop Setup Time	600		ns
$t_{SU:DAT}$	SDA Data Input Setup Time	100		ns
$t_{HD:DAT}$	SDA Data Input Hold Time	0		ns
$t_R$	SCL and SDA Rise Time		300	ns
$t_F$	SCL and SDA Fall Time		300	ns
$t_{AA}$	SCL Low to SDA Data Output Valid Time	250		ns
$t_{DH}$	SDA Data Output Hold Time	0		ns
$T_I$	Noise Suppression Time Constant at SCL and SDA inputs	50		ns
$t_{BUF}$	Bus Free Time (Prior to Any Transmission)	1300		ns
$t_{SU:WPA}$	A0, A1 Setup Time	0		ns
$t_{HD:WPA}$	A0, A1 Hold Time	0		ns

# X9118





## HIGH-VOLTAGE WRITE CYCLE TIMING

Symbol	Parameter	Typ.	Max.	Units
$t_{WR}$	High-voltage write cycle time (store instructions)	5	10	ms

## XDCP TIMING

Symbol	Parameter	Min.	Max.	Units
$t_{WRPO}$	Wiper response time after the third (last) power supply is stable	5	10	$\mu$ s
$t_{WRL}$	Wiper response time after instruction issued (all load instructions)	5	10	$\mu$ s

## SYMBOL TABLE

WAVEFORM	INPUTS	OUTPUTS
	Must be steady	Will be steady
	May change from Low to High	Will change from Low to High
	May change from High to Low	Will change from High to Low
	Don't Care: Changes Allowed	Changing: State Not Known
	N/A	Center Line is High Impedance

# X9118

## TIMING DIAGRAMS

### Start and Stop Timing

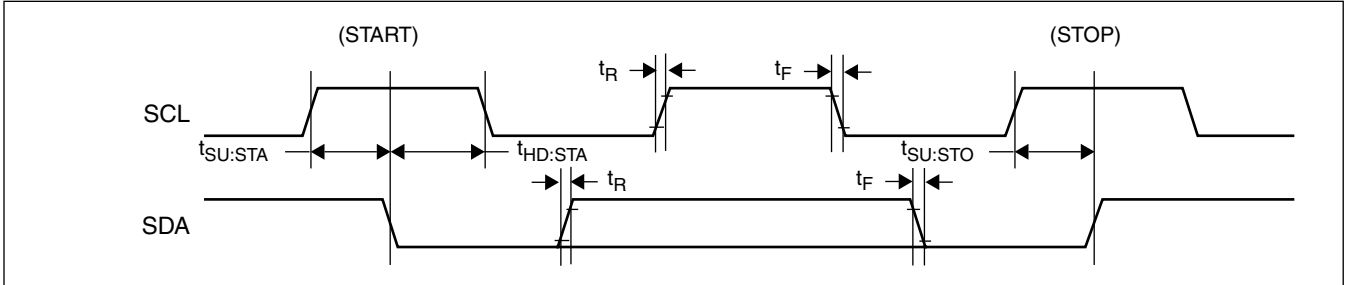

### Input Timing

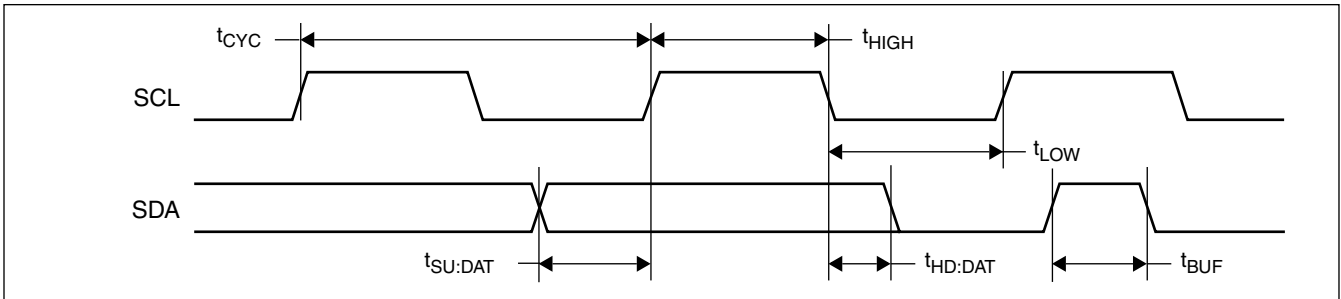

### Output Timing

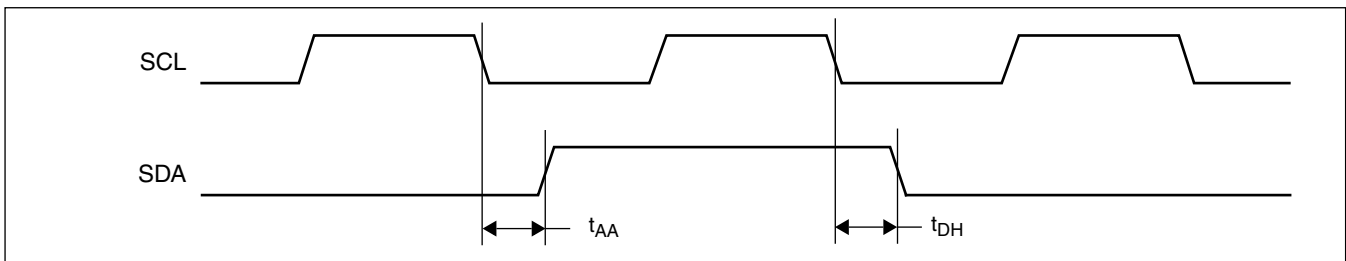



# X9118

## XDCP Timing (for All Load Instructions)

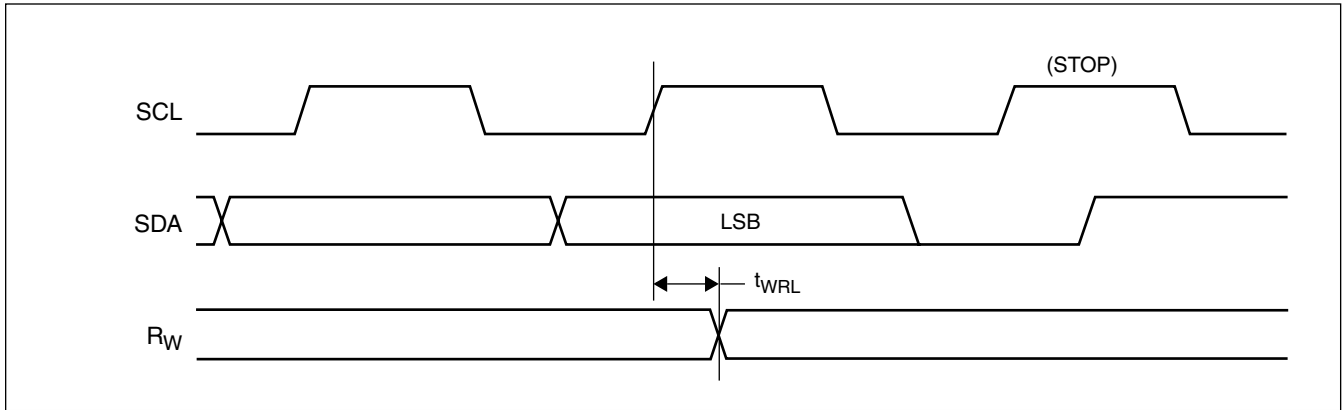

## Write Protect and Device Address Pins Timing

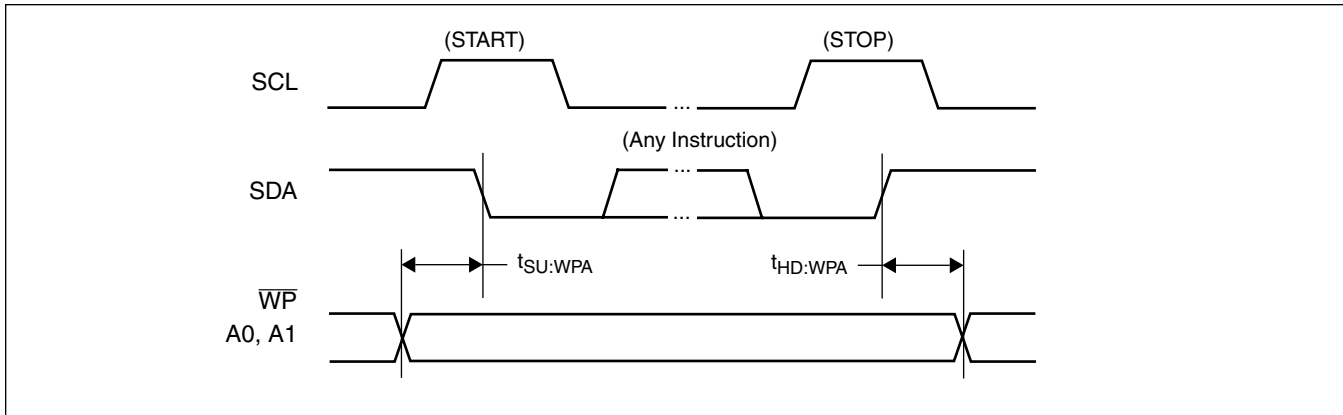

## APPLICATIONS INFORMATION

### Basic Configurations of Electronic Potentiometers

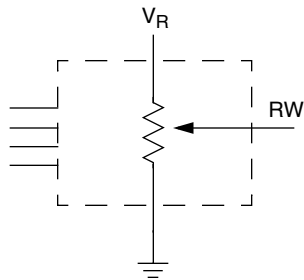

Three terminal Potentiometer;  
Variable voltage divider

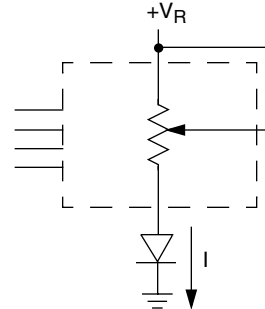

Two terminal Variable Resistor;  
Variable current

### Application Circuits

#### Noninverting Amplifier

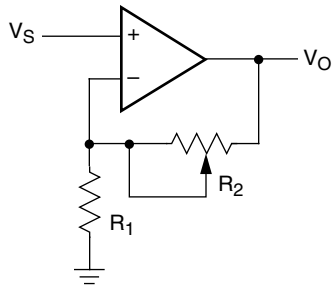

$$V_O = (1 + R_2/R_1)V_S$$

#### Voltage Regulator

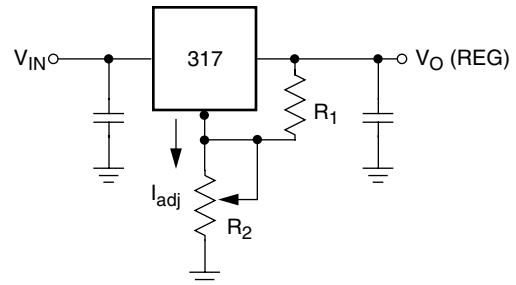

$$V_O (\text{REG}) = 1.25V (1 + R_2/R_1) + I_{\text{adj}} R_2$$

#### Offset Voltage Adjustment

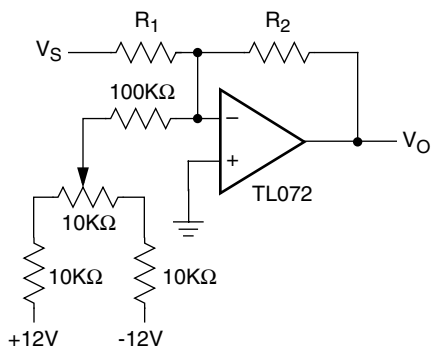

#### Comparator with Hysteresis

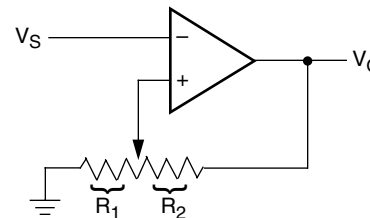

$$V_{UL} = \{R_1/(R_1+R_2)\} V_O(\text{max})$$

$$V_{LL} = \{R_1/(R_1+R_2)\} V_O(\text{min})$$

## Application Circuits (Continued)

### Attenuator

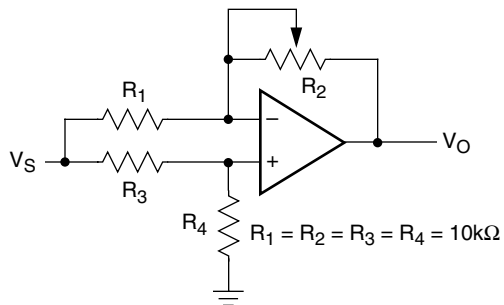

$$V_O = G V_S$$

$$-1/2 \leq G \leq +1/2$$

### Filter

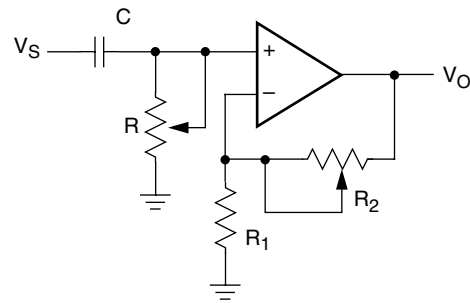

$$G_O = 1 + R_2/R_1$$

$$f_c = 1/(2\pi RC)$$

### Inverting Amplifier

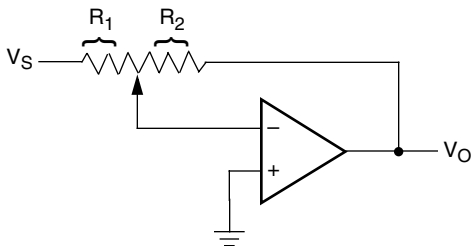

$$V_O = G V_S$$

$$G = -R_2/R_1$$

### Equivalent L-R Circuit

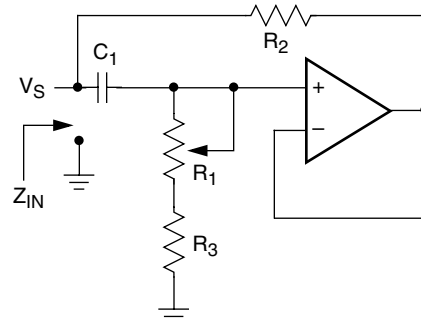

$$Z_{IN} = R_2 + s R_2 (R_1 + R_3) C_1 = R_2 + s L_{eq}$$

$$(R_1 + R_3) \gg R_2$$

### Function Generator

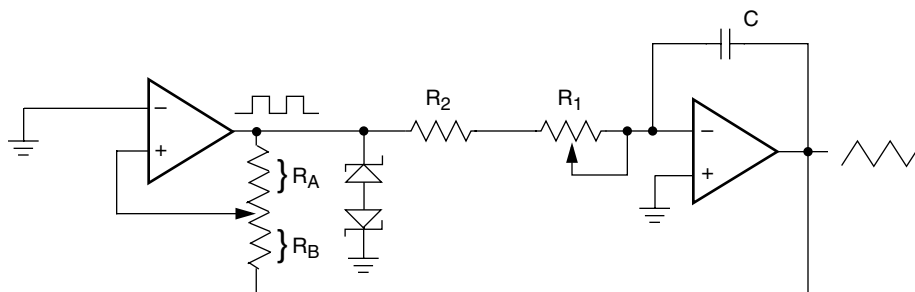

$$\text{frequency} \propto R_1, R_2, C$$

$$\text{amplitude} \propto R_A, R_B$$

# X9118

## XX-ball BGA (X9118xxxxxxx)

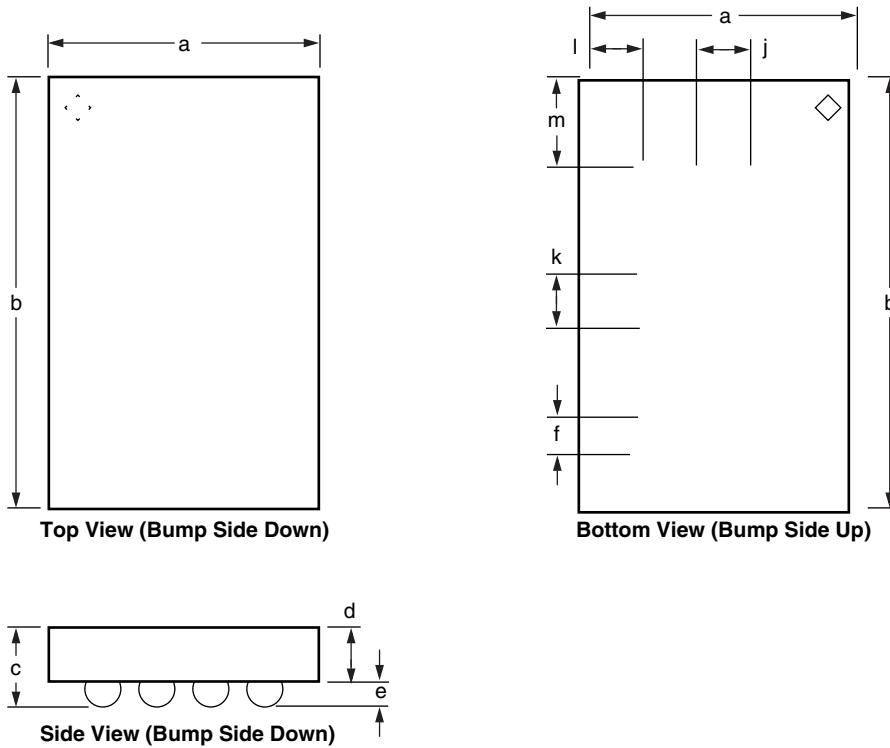

**Note:** Drawing not to scale  
 ◇ = Die Orientation mark

	Symbol	Millimeters			Inches		
		Min	Nom.	Max	Min	Nom.	Max
Package Body Dimension X	a						
Package Body Dimension Y	b						
Package Height	c						
Package Body Thickness	d						
Ball Height	e						
Ball Diameter	f						
Total Ball Count	g						
Ball Count X Axis	h						
Ball Count Y Axis	i						
Pins Pitch XAxis	j						
Pins Pitch Y Axis	k						
Edge to Ball Center (Corner) Distance Along X	l						
Edge to Ball Center (Corner) Distance Along Y	m						

# X9118

## PACKAGING INFORMATION

### 14-Lead Plastic, TSSOP, Package Type V

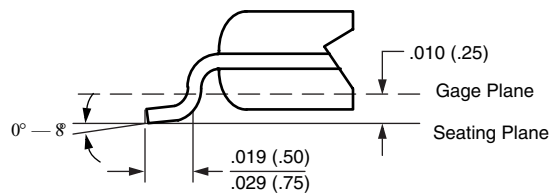
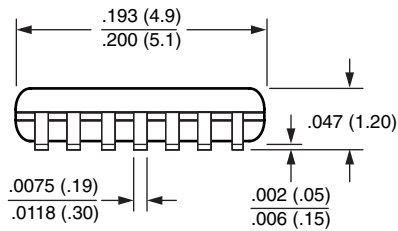
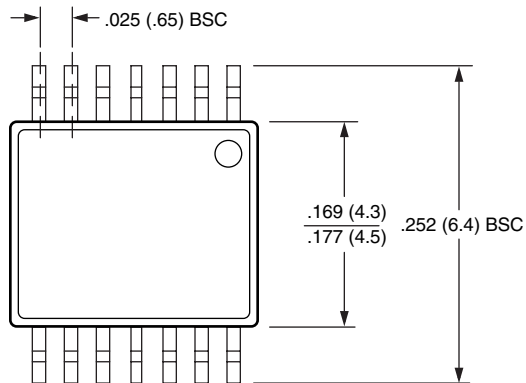

Detail A (20X)

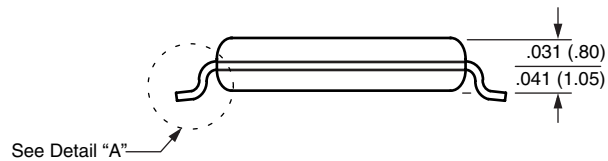

NOTE: ALL DIMENSIONS IN INCHES (IN PARENTHESES IN MILLIMETERS)

# X9118

## ORDERING INFORMATION

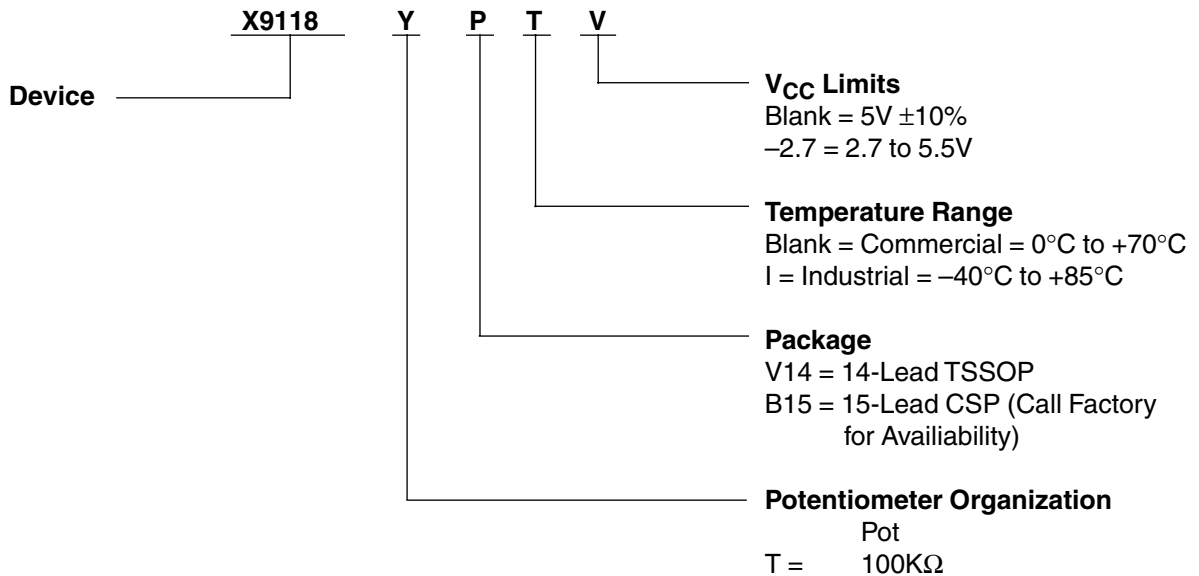

### LIMITED WARRANTY

©Xicor, Inc. 2003 Patents Pending

Devices sold by Xicor, Inc. are covered by the warranty and patent indemnification provisions appearing in its Terms of Sale only. Xicor, Inc. makes no warranty, express, statutory, implied, or by description regarding the information set forth herein or regarding the freedom of the described devices from patent infringement. Xicor, Inc. makes no warranty of merchantability or fitness for any purpose. Xicor, Inc. reserves the right to discontinue production and change specifications and prices at any time and without notice.

Xicor, Inc. assumes no responsibility for the use of any circuitry other than circuitry embodied in a Xicor, Inc. product. No other circuits, patents, or licenses are implied.

### TRADEMARK DISCLAIMER:

Xicor and the Xicor logo are registered trademarks of Xicor, Inc. AutoStore, Direct Write, Block Lock, SerialFlash, MPS, and XDCP are also trademarks of Xicor, Inc. All others belong to their respective owners.

### U.S. PATENTS

Xicor products are covered by one or more of the following U.S. Patents: 4,326,134; 4,393,481; 4,404,475; 4,450,402; 4,486,769; 4,488,060; 4,520,461; 4,533,846; 4,599,706; 4,617,652; 4,668,932; 4,752,912; 4,829,482; 4,874,967; 4,883,976; 4,980,859; 5,012,132; 5,003,197; 5,023,694; 5,084,667; 5,153,880; 5,153,691; 5,161,137; 5,219,774; 5,270,927; 5,324,676; 5,434,396; 5,544,103; 5,587,573; 5,835,409; 5,977,585. Foreign patents and additional patents pending.

### LIFE RELATED POLICY

In situations where semiconductor component failure may endanger life, system designers using this product should design the system with appropriate error detection and correction, redundancy and back-up features to prevent such an occurrence.

Xicor's products are not authorized for use in critical components in life support devices or systems.

1. Life support devices or systems are devices or systems which, (a) are intended for surgical implant into the body, or (b) support or sustain life, and whose failure to perform, when properly used in accordance with instructions for use provided in the labeling, can be reasonably expected to result in a significant injury to the user.
2. A critical component is any component of a life support device or system whose failure to perform can be reasonably expected to cause the failure of the life support device or system, or to affect its safety or effectiveness.