

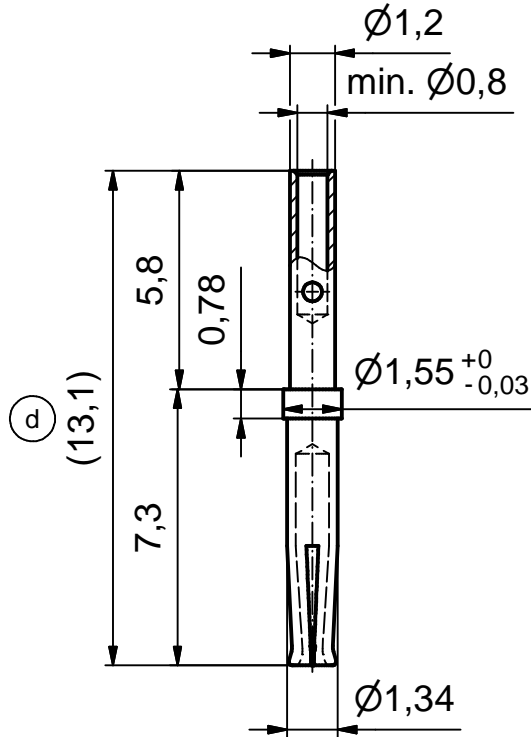

STRIPPING DIMENSION (b) (d)

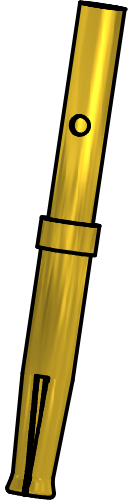
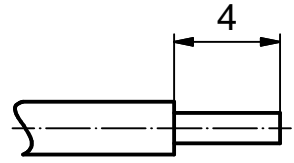

Part-no. as per finish		
(d) GOLD FLASH over NICKEL (e)	min. 20µm HARD GOLD over min. 50µm NICKEL	min. 30µm HARD GOLD over min. 50µm NICKEL
162A18419X	162B18419X	162C18419X

(b) (c) (d) NOTES:

1. Material: Copper alloy
2. Finish: See table
3. Temperature range: -55 °C to +125 °C
4. Rated current: 3 A maximum
5. Contact resistance: <= 10 mOhm
6. Crimping: Use crimp tool 360X10329X
With tool insert 360X10629X
Selector settings: 4 for AWG 22
3 for AWG 24
2 for AWG 26
1 for AWG 28

Directive 2002/95/EC RoHS compliant

THIS DRAWING MAY NOT BE COPIED OR REPRODUCED IN ANY WAY, AND MAY NOT BE PASSED ON TO A THIRD PARTY WITHOUT WRITTEN PERMISSION. OWNERSHIP AND COPYRIGHT OF CONEC GmbH

DO NOT ALTER CAD DRAWING BY HAND

				tolerance	dim. in mm	
				date	name	
				drawn	12.03.01	Parei
1 x e	Ä 4116	26.09.11	Lehm.	appd.	12.03.01	Mickenbecker
4 x d	Ä 3698	25.08.10	Lehm.	norm		
1 x c	Ä 3679	24.06.10	Petker	d-old		
2 x b	Ä 2647	11.01.07	Lehm.			
a	Original					
rev.	description	date	name			

scale:	5:1	
material:	SEE NOTES	
title:	HD CRIMP SOCKET CONTACT screw machined version accepts cable AWG 28-22	
dwg no:	Inventor 10	DIN-A4
	16K1A153A	sh: 1
part no:	SEE TABLE	

