

HEF4060B

14-stage ripple-carry binary counter/divider and oscillator

Rev. 7 — 16 November 2011

Product data sheet

1. General description

The HEF4060B is a 14-stage ripple-carry binary counter/divider and oscillator with three oscillator terminals (RS, REXT and CEXT), ten buffered outputs (Q3 to Q9 and Q11 to Q13) and an overriding asynchronous master reset input (MR).

The oscillator configuration allows design of either RC or crystal oscillator circuits. The oscillator may be replaced by an external clock signal at input RS. The clock input's Schmitt-trigger action makes it highly tolerant to slower clock rise and fall times. The counter advances on the negative-going transition of RS. A HIGH level on MR resets the counter (Q3 to Q9 and Q11 to Q13 = LOW), independent of other input conditions.

It operates over a recommended V_{DD} power supply range of 3 V to 15 V referenced to V_{SS} (usually ground). Unused inputs must be connected to V_{DD} , V_{SS} , or another input.

2. Features and benefits

- Tolerant of slow clock rise and fall times
- Fully static operation
- 5 V, 10 V, and 15 V parametric ratings
- Standardized symmetrical output characteristics
- Inputs and outputs are protected against electrostatic effects
- Specified from $-40\text{ }^{\circ}\text{C}$ to $+85\text{ }^{\circ}\text{C}$
- Complies with JEDEC standard JESD 13-B

3. Ordering information

Table 1. Ordering information

All types operate from $-40\text{ }^{\circ}\text{C}$ to $+85\text{ }^{\circ}\text{C}$.

| Type number | Package | | Version |
|-------------|---------|--|----------|
| | Name | Description | |
| HEF4060BP | DIP16 | plastic dual in-line package; 16 leads (300 mil) | SOT38-4 |
| HEF4060BT | SO16 | plastic small outline package; 16 leads; body width 3.9 mm | SOT109-1 |



4. Functional diagram

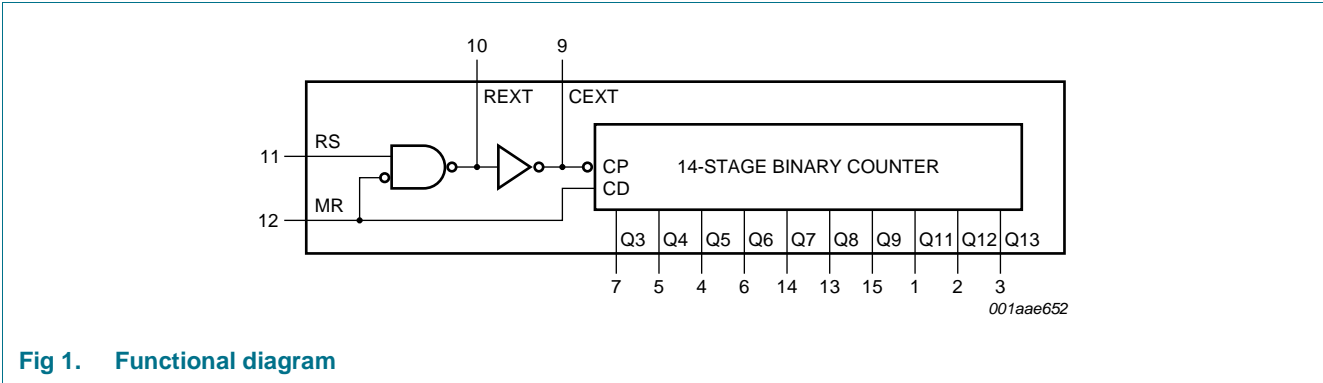

Fig 1. Functional diagram

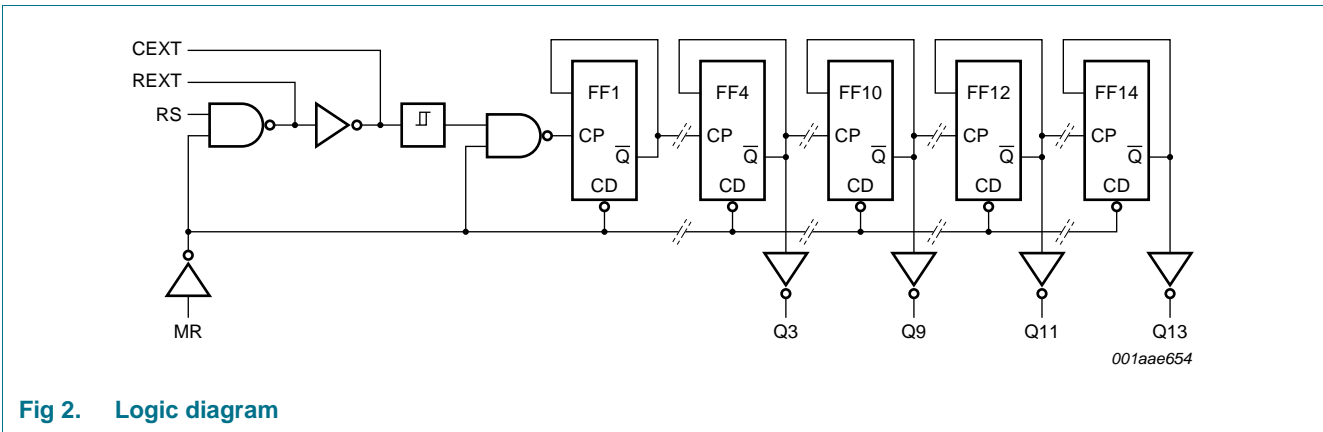

Fig 2. Logic diagram

5. Pinning information

5.1 Pinning

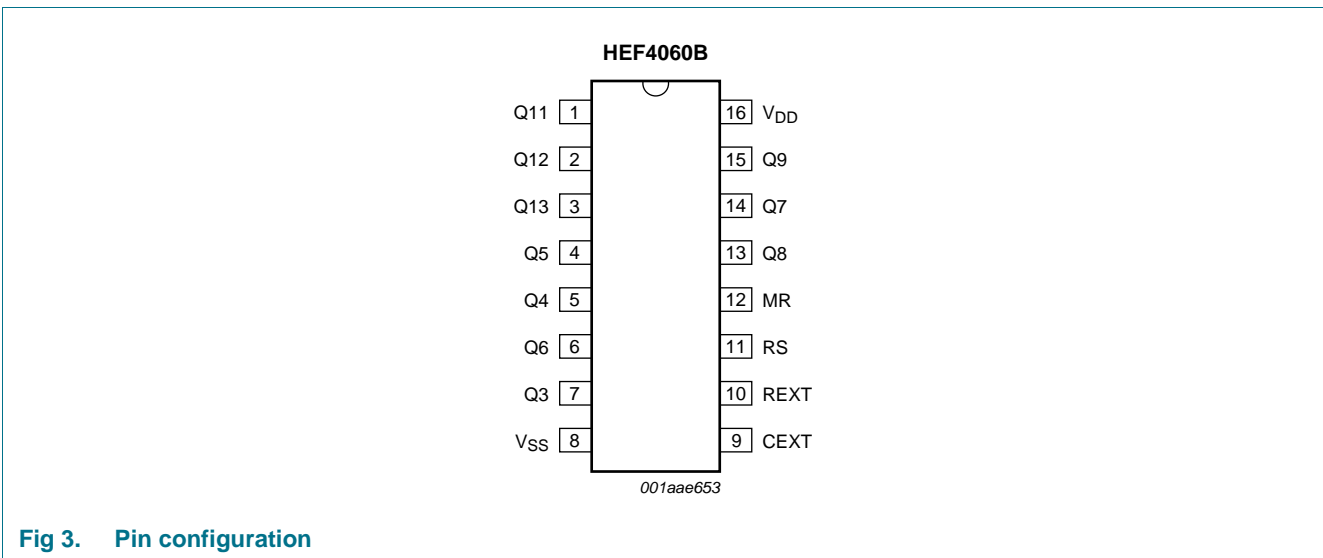

Fig 3. Pin configuration

5.2 Pin description

Table 2. Pin description

| Symbol | Pin | Description |
|-----------------|------------------------|-------------------------------|
| Q11 to Q13 | 1, 2, 3 | counter output |
| Q3 to Q9 | 7, 5, 4, 6, 14, 13, 15 | counter output |
| V _{SS} | 8 | ground supply voltage |
| CEXT | 9 | external capacitor connection |
| REXT | 10 | oscillator pin |
| RS | 11 | clock input/oscillator pin |
| MR | 12 | master reset |
| V _{DD} | 16 | supply voltage |

6. Functional description

Table 3. Function table^[1]

| Input | | Output |
|-------|----|-------------------------|
| RS | MR | Q3 to Q9 and Q11 to Q13 |
| ↑ | L | no change |
| ↓ | L | count |
| X | H | L |

[1] H = HIGH voltage level; L = LOW voltage level; ↑ = LOW-to-HIGH clock transition; ↓ HIGH-to-LOW clock transition.

7. Limiting values

Table 4. Limiting values

In accordance with the Absolute Maximum Rating System (IEC 60134).

| Symbol | Parameter | Conditions | Min | Max | Unit | |
|------------------|-------------------------|---|------|-----------------------|------|----|
| V _{DD} | supply voltage | | -0.5 | +18 | V | |
| I _{IK} | input clamping current | V _I < -0.5 V or V _I > V _{DD} + 0.5 V | - | ±10 | mA | |
| V _I | input voltage | | -0.5 | V _{DD} + 0.5 | V | |
| I _{OK} | output clamping current | V _O < -0.5 V or V _O > V _{DD} + 0.5 V | - | ±10 | mA | |
| I _{I/O} | input/output current | | - | ±10 | mA | |
| I _{DD} | supply current | | - | 50 | mA | |
| T _{stg} | storage temperature | | -65 | +150 | °C | |
| T _{amb} | ambient temperature | | -40 | +85 | °C | |
| P _{tot} | total power dissipation | T _{amb} -40 °C to +85 °C | | | | |
| | | DIP16 package | [1] | - | 750 | mW |
| | | SO16 package | [2] | - | 500 | mW |
| P | power dissipation | per output | - | 100 | mW | |

[1] For DIP16 package: P_{tot} derates linearly with 12 mW/K above 70 °C.

[2] For SO16 package: P_{tot} derates linearly with 8 mW/K above 70 °C.

8. Recommended operating conditions

Table 5. Recommended operating conditions

| Symbol | Parameter | Conditions | Min | Typ | Max | Unit |
|---------------------|-------------------------------------|------------------------|-----|-----|----------|-----------------|
| V_{DD} | supply voltage | | 3 | - | 15 | V |
| V_I | input voltage | | 0 | - | V_{DD} | V |
| T_{amb} | ambient temperature | in free air | -40 | - | +85 | °C |
| $\Delta t/\Delta V$ | input transition rise and fall rate | input MR | | | | |
| | | $V_{DD} = 5\text{ V}$ | - | - | 3.75 | $\mu\text{s/V}$ |
| | | $V_{DD} = 10\text{ V}$ | - | - | 0.5 | $\mu\text{s/V}$ |
| | | $V_{DD} = 15\text{ V}$ | - | - | 0.08 | $\mu\text{s/V}$ |

9. Static characteristics

Table 6. Static characteristics

$V_{SS} = 0\text{ V}$; $V_I = V_{SS}$ or V_{DD} unless otherwise specified.

| Symbol | Parameter | Conditions | V_{DD} | $T_{amb} = -40\text{ °C}$ | | $T_{amb} = 25\text{ °C}$ | | $T_{amb} = 85\text{ °C}$ | | Unit |
|----------|---------------------------|--------------------------|----------|---------------------------|-----------|--------------------------|-----------|--------------------------|-----------|---------------|
| | | | | Min | Max | Min | Max | Min | Max | |
| V_{IH} | HIGH-level input voltage | $ I_O < 1\ \mu\text{A}$ | 5 V | 3.5 | - | 3.5 | - | 3.5 | - | V |
| | | | 10 V | 7.0 | - | 7.0 | - | 7.0 | - | V |
| | | | 15 V | 11.0 | - | 11.0 | - | 11.0 | - | V |
| V_{IL} | LOW-level input voltage | $ I_O < 1\ \mu\text{A}$ | 5 V | - | 1.5 | - | 1.5 | - | 1.5 | V |
| | | | 10 V | - | 3.0 | - | 3.0 | - | 3.0 | V |
| | | | 15 V | - | 4.0 | - | 4.0 | - | 4.0 | V |
| V_{OH} | HIGH-level output voltage | $ I_O < 1\ \mu\text{A}$ | 5 V | 4.95 | - | 4.95 | - | 4.95 | - | V |
| | | | 10 V | 9.95 | - | 9.95 | - | 9.95 | - | V |
| | | | 15 V | 14.95 | - | 14.95 | - | 14.95 | - | V |
| V_{OL} | LOW-level output voltage | $ I_O < 1\ \mu\text{A}$ | 5 V | - | 0.05 | - | 0.05 | - | 0.05 | V |
| | | | 10 V | - | 0.05 | - | 0.05 | - | 0.05 | V |
| | | | 15 V | - | 0.05 | - | 0.05 | - | 0.05 | V |
| I_{OH} | HIGH-level output current | $V_O = 2.5\text{ V}$ | 5 V | - | -1.7 | - | -1.4 | - | -1.1 | mA |
| | | $V_O = 4.6\text{ V}$ | 5 V | - | -0.52 | - | -0.44 | - | -0.36 | mA |
| | | $V_O = 9.5\text{ V}$ | 10 V | - | -1.3 | - | -1.1 | - | -0.9 | mA |
| | | $V_O = 13.5\text{ V}$ | 15 V | - | -3.6 | - | -3.0 | - | -2.4 | mA |
| I_{OL} | LOW-level output current | $V_O = 0.4\text{ V}$ | 5 V | 0.52 | - | 0.44 | - | 0.36 | - | mA |
| | | $V_O = 0.5\text{ V}$ | 10 V | 1.3 | - | 1.1 | - | 0.9 | - | mA |
| | | $V_O = 1.5\text{ V}$ | 15 V | 3.6 | - | 3.0 | - | 2.4 | - | mA |
| I_I | input leakage current | | 15 V | - | ± 0.3 | - | ± 0.3 | - | ± 1.0 | μA |
| I_{DD} | supply current | $I_O = 0\text{ A}$ | 5 V | - | 20 | - | 20 | - | 150 | μA |
| | | | 10 V | - | 40 | - | 40 | - | 300 | μA |
| | | | 15 V | - | 80 | - | 80 | - | 600 | μA |
| C_I | input capacitance | | - | - | - | - | 7.5 | - | - | pF |

10. Dynamic characteristics

Table 7. Dynamic characteristics

$T_{amb} = 25\text{ }^{\circ}\text{C}$; $V_{SS} = 0\text{ V}$; $C_L = 50\text{ pF}$; $t_r = t_f \leq 20\text{ ns}$; unless otherwise specified.

| Symbol | Parameter | Conditions | V_{DD} | Extrapolation formula ^[1] | Min | Typ | Max | Unit |
|-----------|-------------------|---|--------------------|---|-----|-----|-----|------|
| t_{pd} | propagation delay | RS \rightarrow Q3; see Figure 4 | 5 V ^[2] | $183\text{ ns} + (0.55\text{ ns/pF}) C_L$ | - | 210 | 420 | ns |
| | | | 10 V | $69\text{ ns} + (0.23\text{ ns/pF}) C_L$ | - | 80 | 160 | ns |
| | | | 15 V | $42\text{ ns} + (0.16\text{ ns/pF}) C_L$ | - | 50 | 100 | ns |
| | | Qn \rightarrow Qn + 1; see Figure 4 | 5 V | - | - | 25 | 50 | ns |
| | | | 10 V | - | - | 10 | 20 | ns |
| | | | 15 V | - | - | 6 | 12 | ns |
| | | MR \rightarrow Qn; HIGH to LOW see Figure 4 | 5 V | $73\text{ ns} + (0.55\text{ ns/pF}) C_L$ | - | 100 | 200 | ns |
| | | | 10 V | $29\text{ ns} + (0.23\text{ ns/pF}) C_L$ | - | 40 | 80 | ns |
| | | | 15 V | $22\text{ ns} + (0.16\text{ ns/pF}) C_L$ | - | 30 | 60 | ns |
| t_t | transition time | see Figure 4 | 5 V ^[3] | $10\text{ ns} + (1.00\text{ ns/pF}) C_L$ | - | 60 | 120 | ns |
| | | | 10 V | $9\text{ ns} + (0.42\text{ ns/pF}) C_L$ | - | 30 | 60 | ns |
| | | | 15 V | $6\text{ ns} + (0.28\text{ ns/pF}) C_L$ | - | 20 | 40 | ns |
| t_w | pulse width | minimum width; RS HIGH; see Figure 4 | 5 V | - | 120 | 60 | - | ns |
| | | | 10 V | - | 50 | 25 | - | ns |
| | | | 15 V | - | 30 | 15 | - | ns |
| | | minimum width; MR HIGH; see Figure 4 | 5 V | - | 50 | 25 | - | ns |
| | | | 10 V | - | 30 | 15 | - | ns |
| | | | 15 V | - | 20 | 10 | - | ns |
| t_{rec} | recovery time | input MR; see Figure 4 | 5 V | - | 160 | 80 | - | ns |
| | | | 10 V | - | 80 | 40 | - | ns |
| | | | 15 V | - | 60 | 30 | - | ns |
| f_{max} | maximum frequency | input RS; see Figure 4 | 5 V | - | 4 | 8 | - | MHz |
| | | | 10 V | - | 10 | 20 | - | MHz |
| | | | 15 V | - | 15 | 30 | - | MHz |

[1] The typical values of the propagation delay and transition times are calculated from the extrapolation formulas shown (C_L in pF).

[2] t_{pd} is the same as t_{PHL} and t_{PLH} .

[3] t_t is the same as t_{THL} and t_{TLH} .

Table 8. Power dissipation

Dynamic power dissipation P_D and total power dissipation P_{tot} can be calculated from the formulas shown. $T_{amb} = 25\text{ }^\circ\text{C}$.

| Symbol | Parameter | Conditions | V_{DD} | Typical formula for P_D and P_{tot} (μW) ^[1] |
|-----------|---------------------------|-----------------------------------|----------|--|
| P_D | dynamic power dissipation | per device | 5 V | $P_D = 700 \times f_i + \Sigma(f_o \times C_L) \times V_{DD}^2$ |
| | | | 10 V | $P_D = 3300 \times f_i + \Sigma(f_o \times C_L) \times V_{DD}^2$ |
| | | | 15 V | $P_D = 8900 \times f_i + \Sigma(f_o \times C_L) \times V_{DD}^2$ |
| P_{tot} | total power dissipation | when using the on-chip oscillator | 5 V | $P_{tot} = 700 \times f_{osc} + \Sigma(f_o \times C_L) \times V_{DD}^2 + 2 \times C_t \times V_{DD}^2 \times f_{osc} + 690 \times V_{DD}$ |
| | | | 10 V | $P_{tot} = 3300 \times f_{osc} + \Sigma(f_o \times C_L) \times V_{DD}^2 + 2 \times C_t \times V_{DD}^2 \times f_{osc} + 6900 \times V_{DD}$ |
| | | | 15 V | $P_{tot} = 8900 \times f_{osc} + \Sigma(f_o \times C_L) \times V_{DD}^2 + 2 \times C_t \times V_{DD}^2 \times f_{osc} + 22000 \times V_{DD}$ |

[1] Where:

- f_i = input frequency in MHz; f_o = output frequency in MHz;
- C_L = output load capacitance in pF;
- V_{DD} = supply voltage in V;
- $\Sigma(f_o \times C_L)$ = sum of the outputs;
- C_t = timing capacitance (pF);
- f_{osc} = oscillator frequency (MHz).

11. Waveforms

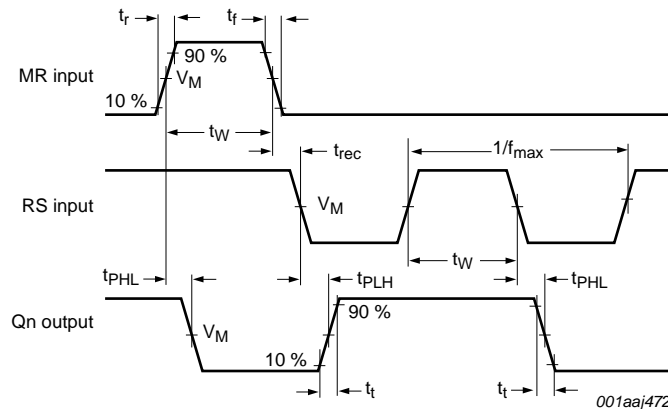

Measurement points are given in [Table 9](#).

Fig 4. Waveforms showing propagation delays for MR to Qn and \overline{CP} to Q0, minimum MR, and \overline{CP} pulse widths

Table 9. Measurement points

| Supply voltage | Input | Output |
|----------------|-------------|-------------|
| V_{DD} | V_M | V_M |
| 5 V to 15 V | $0.5V_{DD}$ | $0.5V_{DD}$ |

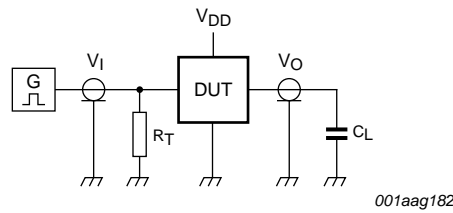

Test data is given in [Table 10](#).

Definitions for test circuit:

DUT = Device Under Test;

C_L = load capacitance including jig and probe capacitance;

R_T = termination resistance should be equal to the output impedance Z_o of the pulse generator.

Fig 5. Test circuit for switching times

Table 10. Measurement point and test data

| Supply voltage | Input | | Load |
|----------------|----------------------|--------------|-------|
| V_{DD} | V_I | t_r, t_f | C_L |
| 5 V to 15 V | V_{SS} or V_{DD} | ≤ 20 ns | 50 pF |

12. RC oscillator

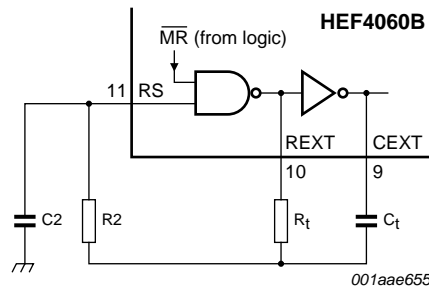

Typical formula for oscillator frequency:
$$f_{osc} = \frac{1}{2.3 \times R_t \times C_t}$$

Fig 6. External component connection for RC oscillator

12.1 Timing component limitations

The oscillator frequency is mainly determined by $R_t \times C_t$, provided $R_t \ll R_2$ and $R_2 \times C_2 \ll R_t \times C_t$. The influence of the forward voltage across the input protection diodes on the frequency is minimized by R_2 . The stray capacitance C_2 should be kept as small as possible. In consideration of accuracy, C_t must be larger than the inherent stray capacitance. R_t must be larger than the LOCMOS (Local Oxidation Complementary Metal-Oxide Semiconductor) 'ON' resistance in series with it, which typically is 500 Ω at $V_{DD} = 5$ V, 300 Ω at $V_{DD} = 10$ V and 200 Ω at $V_{DD} = 15$ V.

The recommended values for these components to maintain agreement with the typical oscillation formula are:

$$C_t \geq 100 \text{ pF, up to any practical value,}$$

$$10 \text{ k}\Omega \leq R_t \leq 1 \text{ M}\Omega.$$

12.2 Typical crystal oscillator circuit

In [Figure 7](#), R2 is the power limiting resistor. For starting and maintaining oscillation a minimum transconductance is necessary.

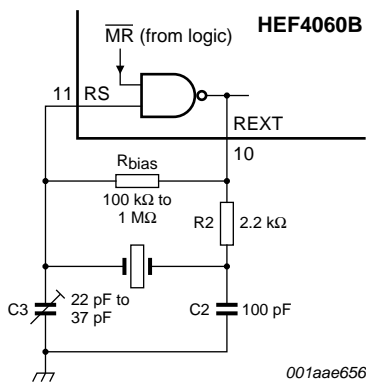
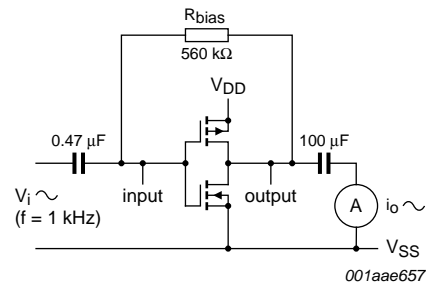
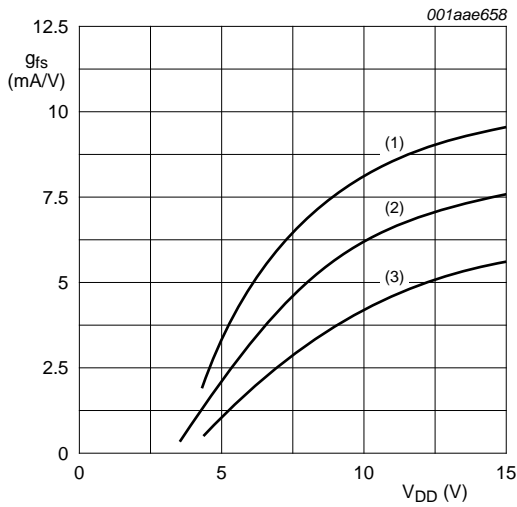

Fig 7. External component connection for crystal oscillator



$g_{fs} = di_o/dv_i$ at v_o is constant (see also [Figure 9](#));
MR = LOW.

Fig 8. Test setup for measuring forward transconductance (g_{fs})



$T_{amb} = 25\text{ }^{\circ}\text{C}$.
 (1) Average + 2 σ .
 (2) Average.
 (3) Average - 2 σ .
 Where ' σ ' is the observed standard deviation.

Fig 9. Typical forward transconductance g_{fs} as a function of the supply voltage

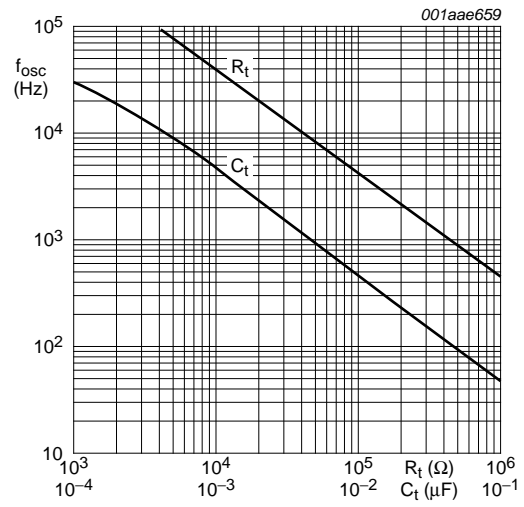

C_t curve at $R_t = 100\text{ k}\Omega$; $R_2 = 470\text{ k}\Omega$.
 R_t curve at $C_t = 1\text{ nF}$; $R_2 = 5 R_t$.
 $V_{DD} = 5\text{ V to } 15\text{ V}$; $T_{amb} = 25\text{ }^{\circ}\text{C}$.

Fig 10. RC oscillator frequency as a function of R_t and C_t

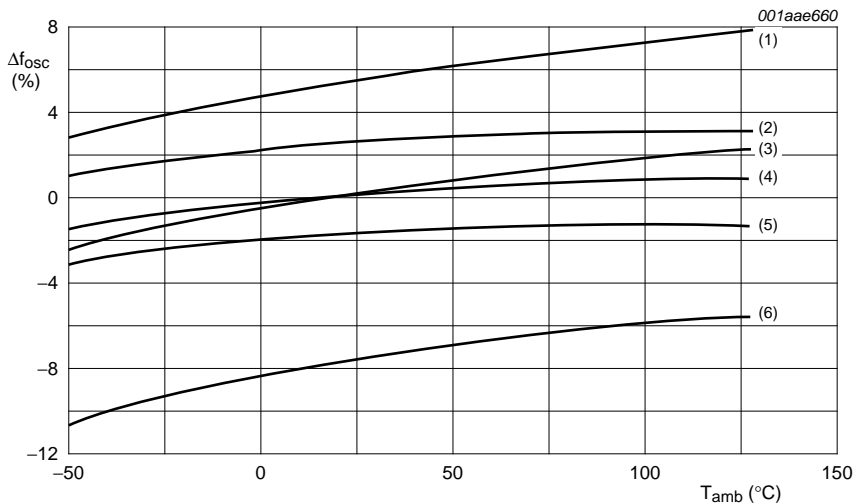

Lines (1) and (2): $V_{DD} = 15\text{ V}$.
 Lines (3) and (4): $V_{DD} = 10\text{ V}$.
 Lines (5) and (6): $V_{DD} = 5\text{ V}$.
 Lines (1), (3), (6): $R_t = 100\text{ k}\Omega$; $C_t = 1\text{ nF}$; $R_2 = 0\text{ W}$.
 Lines (2), (4), (5): $R_t = 100\text{ k}\Omega$; $C_t = 1\text{ nF}$; $R_2 = 300\text{ k}\Omega$.
 Referenced at: f_{osc} at $T_{amb} = 25\text{ }^{\circ}\text{C}$ and $V_{DD} = 10\text{ V}$.

Fig 11. Oscillator frequency deviation (Δf_{osc}) as a function of ambient temperature

13. Package outline

DIP16: plastic dual in-line package; 16 leads (300 mil)

SOT38-4

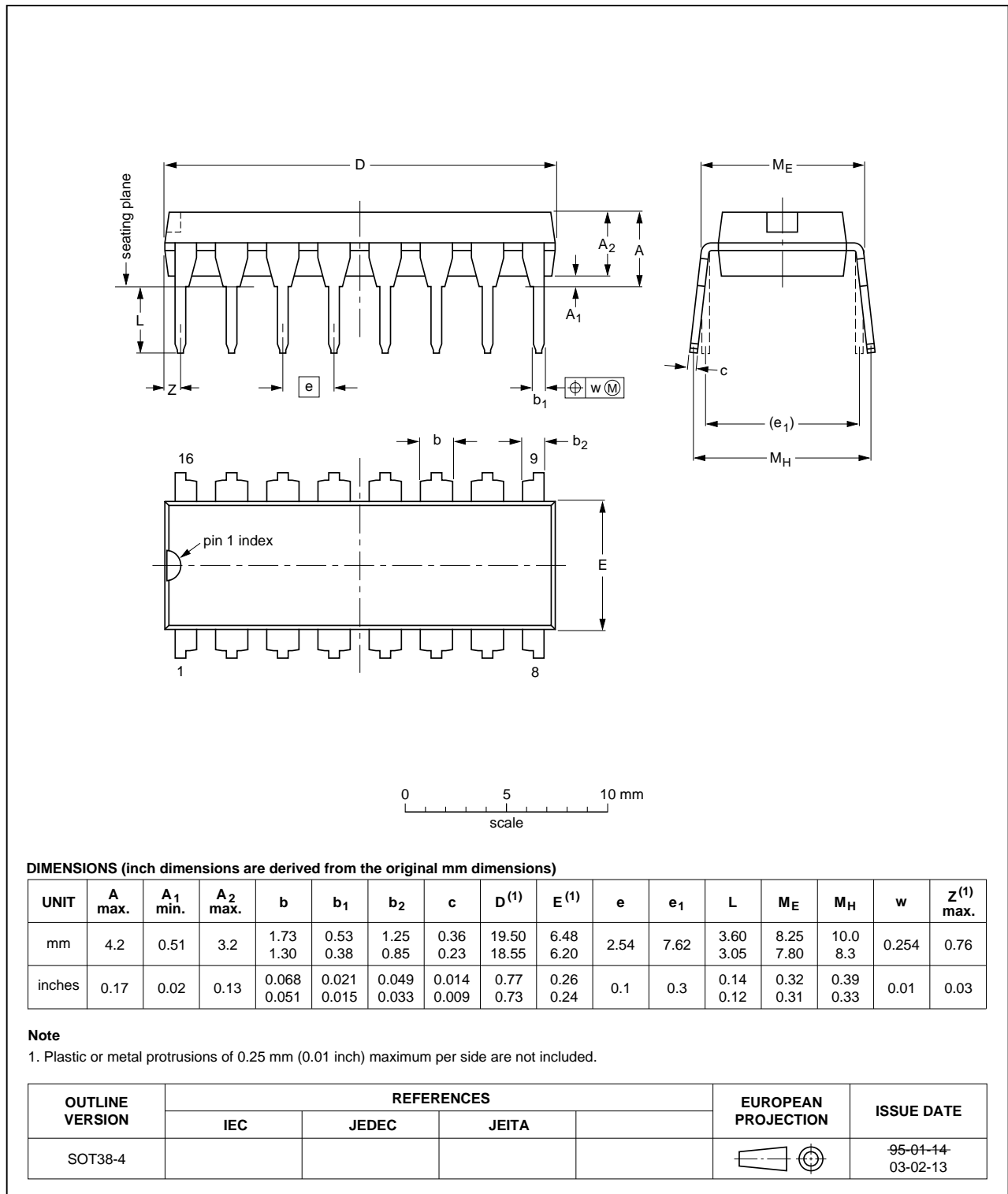

Fig 12. Package outline SOT38-4 (DIP16)

SO16: plastic small outline package; 16 leads; body width 3.9 mm

SOT109-1

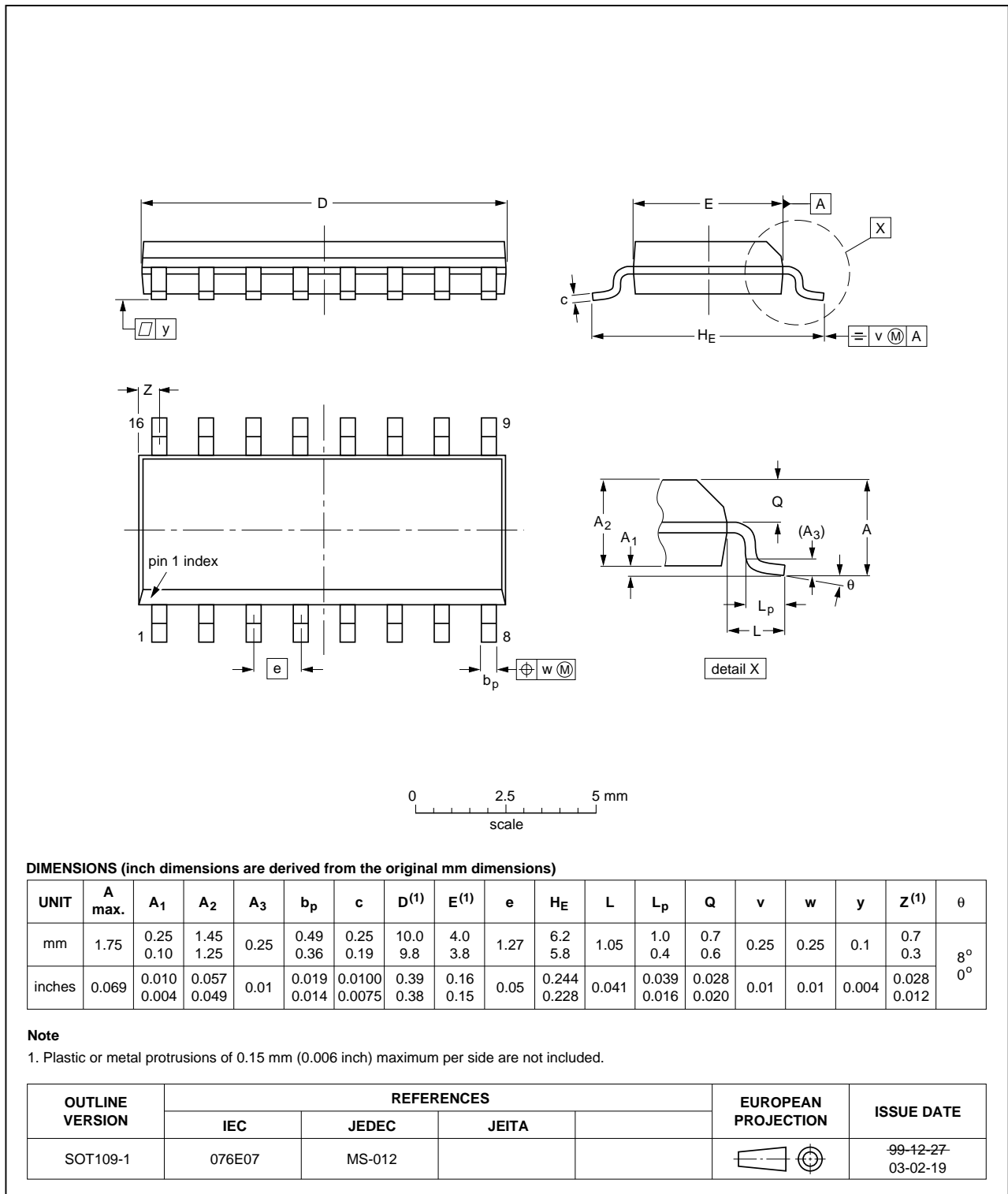

Fig 13. Package outline SOT109-1 (SO16)

14. Revision history

Table 11. Revision history

| Document ID | Release date | Data sheet status | Change notice | Supersedes |
|------------------|--------------|--|---------------|------------------|
| HEF4060B v.7 | 20111116 | Product data sheet | - | HEF4060B v.6 |
| Modifications: | | <ul style="list-style-type: none">• Legal pages updated.• Changes in “General description” and “Features and benefits”.• Section “Applications” removed. | | |
| HEF4060B v.6 | 20110511 | Product data sheet | - | HEF4060B v.5 |
| HEF4060B v.5 | 20091127 | Product data sheet | - | HEF4060B v.4 |
| HEF4060B v.4 | 20090817 | Product data sheet | - | HEF4060B_CNV v.3 |
| HEF4060B_CNV v.3 | 19950101 | Product specification | - | HEF4060B_CNV v.2 |
| HEF4060B_CNV v.2 | 19950101 | Product specification | - | - |

15. Legal information

15.1 Data sheet status

| Document status ^{[1][2]} | Product status ^[3] | Definition |
|-----------------------------------|-------------------------------|---|
| Objective [short] data sheet | Development | This document contains data from the objective specification for product development. |
| Preliminary [short] data sheet | Qualification | This document contains data from the preliminary specification. |
| Product [short] data sheet | Production | This document contains the product specification. |

[1] Please consult the most recently issued document before initiating or completing a design.

[2] The term 'short data sheet' is explained in section "Definitions".

[3] The product status of device(s) described in this document may have changed since this document was published and may differ in case of multiple devices. The latest product status information is available on the Internet at URL <http://www.nxp.com>.

15.2 Definitions

Draft — The document is a draft version only. The content is still under internal review and subject to formal approval, which may result in modifications or additions. NXP Semiconductors does not give any representations or warranties as to the accuracy or completeness of information included herein and shall have no liability for the consequences of use of such information.

Short data sheet — A short data sheet is an extract from a full data sheet with the same product type number(s) and title. A short data sheet is intended for quick reference only and should not be relied upon to contain detailed and full information. For detailed and full information see the relevant full data sheet, which is available on request via the local NXP Semiconductors sales office. In case of any inconsistency or conflict with the short data sheet, the full data sheet shall prevail.

Product specification — The information and data provided in a Product data sheet shall define the specification of the product as agreed between NXP Semiconductors and its customer, unless NXP Semiconductors and customer have explicitly agreed otherwise in writing. In no event however, shall an agreement be valid in which the NXP Semiconductors product is deemed to offer functions and qualities beyond those described in the Product data sheet.

15.3 Disclaimers

Limited warranty and liability — Information in this document is believed to be accurate and reliable. However, NXP Semiconductors does not give any representations or warranties, expressed or implied, as to the accuracy or completeness of such information and shall have no liability for the consequences of use of such information.

In no event shall NXP Semiconductors be liable for any indirect, incidental, punitive, special or consequential damages (including - without limitation - lost profits, lost savings, business interruption, costs related to the removal or replacement of any products or rework charges) whether or not such damages are based on tort (including negligence), warranty, breach of contract or any other legal theory.

Notwithstanding any damages that customer might incur for any reason whatsoever, NXP Semiconductors' aggregate and cumulative liability towards customer for the products described herein shall be limited in accordance with the *Terms and conditions of commercial sale* of NXP Semiconductors.

Right to make changes — NXP Semiconductors reserves the right to make changes to information published in this document, including without limitation specifications and product descriptions, at any time and without notice. This document supersedes and replaces all information supplied prior to the publication hereof.

Suitability for use — NXP Semiconductors products are not designed, authorized or warranted to be suitable for use in life support, life-critical or safety-critical systems or equipment, nor in applications where failure or

malfunction of an NXP Semiconductors product can reasonably be expected to result in personal injury, death or severe property or environmental damage. NXP Semiconductors accepts no liability for inclusion and/or use of NXP Semiconductors products in such equipment or applications and therefore such inclusion and/or use is at the customer's own risk.

Applications — Applications that are described herein for any of these products are for illustrative purposes only. NXP Semiconductors makes no representation or warranty that such applications will be suitable for the specified use without further testing or modification.

Customers are responsible for the design and operation of their applications and products using NXP Semiconductors products, and NXP Semiconductors accepts no liability for any assistance with applications or customer product design. It is customer's sole responsibility to determine whether the NXP Semiconductors product is suitable and fit for the customer's applications and products planned, as well as for the planned application and use of customer's third party customer(s). Customers should provide appropriate design and operating safeguards to minimize the risks associated with their applications and products.

NXP Semiconductors does not accept any liability related to any default, damage, costs or problem which is based on any weakness or default in the customer's applications or products, or the application or use by customer's third party customer(s). Customer is responsible for doing all necessary testing for the customer's applications and products using NXP Semiconductors products in order to avoid a default of the applications and the products or of the application or use by customer's third party customer(s). NXP does not accept any liability in this respect.

Limiting values — Stress above one or more limiting values (as defined in the Absolute Maximum Ratings System of IEC 60134) will cause permanent damage to the device. Limiting values are stress ratings only and (proper) operation of the device at these or any other conditions above those given in the Recommended operating conditions section (if present) or the Characteristics sections of this document is not warranted. Constant or repeated exposure to limiting values will permanently and irreversibly affect the quality and reliability of the device.

Terms and conditions of commercial sale — NXP Semiconductors products are sold subject to the general terms and conditions of commercial sale, as published at <http://www.nxp.com/profile/terms>, unless otherwise agreed in a valid written individual agreement. In case an individual agreement is concluded only the terms and conditions of the respective agreement shall apply. NXP Semiconductors hereby expressly objects to applying the customer's general terms and conditions with regard to the purchase of NXP Semiconductors products by customer.

No offer to sell or license — Nothing in this document may be interpreted or construed as an offer to sell products that is open for acceptance or the grant, conveyance or implication of any license under any copyrights, patents or other industrial or intellectual property rights.

Export control — This document as well as the item(s) described herein may be subject to export control regulations. Export might require a prior authorization from competent authorities.

Non-automotive qualified products — Unless this data sheet expressly states that this specific NXP Semiconductors product is automotive qualified, the product is not suitable for automotive use. It is neither qualified nor tested in accordance with automotive testing or application requirements. NXP Semiconductors accepts no liability for inclusion and/or use of non-automotive qualified products in automotive equipment or applications.

In the event that customer uses the product for design-in and use in automotive applications to automotive specifications and standards, customer (a) shall use the product without NXP Semiconductors' warranty of the product for such automotive applications, use and specifications, and (b) whenever customer uses the product for automotive applications beyond

NXP Semiconductors' specifications such use shall be solely at customer's own risk, and (c) customer fully indemnifies NXP Semiconductors for any liability, damages or failed product claims resulting from customer design and use of the product for automotive applications beyond NXP Semiconductors' standard warranty and NXP Semiconductors' product specifications.

15.4 Trademarks

Notice: All referenced brands, product names, service names and trademarks are the property of their respective owners.

16. Contact information

For more information, please visit: <http://www.nxp.com>

For sales office addresses, please send an email to: salesaddresses@nxp.com

17. Contents

| | | |
|-----------|---|-----------|
| 1 | General description | 1 |
| 2 | Features and benefits | 1 |
| 3 | Ordering information | 1 |
| 4 | Functional diagram | 2 |
| 5 | Pinning information | 2 |
| 5.1 | Pinning | 2 |
| 5.2 | Pin description | 3 |
| 6 | Functional description | 3 |
| 7 | Limiting values | 3 |
| 8 | Recommended operating conditions | 4 |
| 9 | Static characteristics | 4 |
| 10 | Dynamic characteristics | 5 |
| 11 | Waveforms | 6 |
| 12 | RC oscillator | 7 |
| 12.1 | Timing component limitations | 7 |
| 12.2 | Typical crystal oscillator circuit | 8 |
| 13 | Package outline | 10 |
| 14 | Revision history | 12 |
| 15 | Legal information | 13 |
| 15.1 | Data sheet status | 13 |
| 15.2 | Definitions | 13 |
| 15.3 | Disclaimers | 13 |
| 15.4 | Trademarks | 14 |
| 16 | Contact information | 14 |
| 17 | Contents | 15 |

Please be aware that important notices concerning this document and the product(s) described herein, have been included in section 'Legal information'.

© NXP B.V. 2011.

All rights reserved.

For more information, please visit: <http://www.nxp.com>

For sales office addresses, please send an email to: salesaddresses@nxp.com

Date of release: 16 November 2011

Document identifier: HEF4060B