

## 54AC161 • 54ACT161 Synchronous Presettable Binary Counter

### General Description

The 'AC/ACT161 are high-speed synchronous modulo-16 binary counters. They are synchronously presettable for application in programmable dividers and have two types of Count Enable inputs plus a Terminal Count output for versatility in forming synchronous multistage counters. The 'AC/ 'ACT161 has an asynchronous Master Reset input that overrides all other inputs and forces the outputs LOW.

- Synchronous counting and loading
- High-speed synchronous expansion
- Typical count rate of 125 MHz
- Outputs source/sink 24 mA
- 'ACT161 has TTL-compatible inputs
- Standard Microcircuit Drawing (SMD)
  - 'AC161: 5962-89561
  - 'ACT161: 5962-91722

### Features

- $I_{CC}$  reduced by 50%

### Logic Symbols

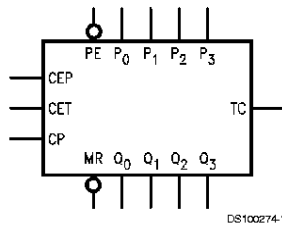

Pin Names	Description
CEP	Count Enable Parallel Input
CET	Count Enable Trickle Input
CP	Clock Pulse Input
$\overline{MR}$	Asynchronous Master Reset Input
$P_0$ – $P_3$	Parallel Data Inputs
$\overline{PE}$	Parallel Enable Inputs
$Q_0$ – $Q_3$	Flip-Flop Outputs
TC	Terminal Count Output

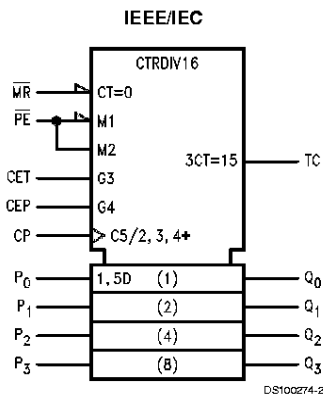

TRI-STATE® is a registered trademark of National Semiconductor Corporation.  
FACT™ is a trademark of Fairchild Semiconductor Corporation.

## Connection Diagrams

Pin Assignment  
for DIP and Flatpak

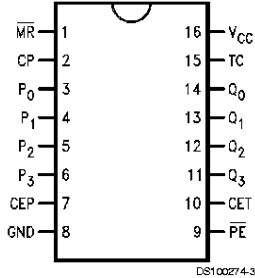

Pin Assignment  
for LCC

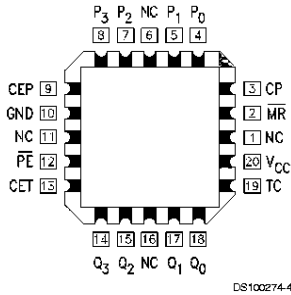

## Functional Description

The 'AC/ACT161 count in modulo-16 binary sequence. From state 15 (HHHH) they increment to state 0 (LLLL). The clock inputs of all flip-flops are driven in parallel through a clock buffer. Thus all changes of the Q outputs (except due to Master Reset of the '161) occur as a result of, and synchronous with, the LOW-to-HIGH transition of the CP input signal. The circuits have four fundamental modes of operation, in order of precedence: asynchronous reset, parallel load, count-up and hold. Five control inputs—Master Reset, Parallel Enable ( $\overline{PE}$ ), Count Enable Parallel (CEP) and Count Enable Trickle (CET)—determine the mode of operation, as shown in the Mode Select Table. A LOW signal on  $\overline{MR}$  overrides all other inputs and asynchronously forces all outputs LOW. A LOW signal on  $\overline{PE}$  overrides counting and allows information on the Parallel Data ( $P_n$ ) inputs to be loaded into the flip-flops on the next rising edge of CP. With  $\overline{PE}$  and  $\overline{MR}$  HIGH, CEP and CET permit counting when both are HIGH. Conversely, a LOW signal on either CEP or CET inhibits counting.

The 'AC/ACT161 use D-type edge-triggered flip-flops and changing the  $\overline{PE}$ , CEP and CET inputs when the CP is in either state does not cause errors, provided that the recommended setup and hold times, with respect to the rising edge of CP, are observed.

The Terminal Count (TC) output is HIGH when CET is HIGH and counter is in state 15. To implement synchronous multi-stage counters, the TC outputs can be used with the CEP and CET inputs in two different ways.

Figure 1 shows the connections for simple ripple carry, in which the clock period must be longer than the CP to  $\overline{TC}$  delay of the first stage, plus the cumulative  $\overline{CET}$  to  $\overline{TC}$  delays of the intermediate stages, plus the  $\overline{CET}$  to CP setup time of the last stage. This total delay plus setup time sets the upper limit on clock frequency. For faster clock rates, the carry lookahead connections shown in Figure 2 are recommended. In this scheme the ripple delay through the intermediate stages commences with the same clock that causes the first stage to tick over from max to min in the Up mode, or min to max in the Down mode, to start its final cycle. Since this final cycle requires 16 clocks to complete, there is plenty of time for the ripple to progress through the intermediate stages. The critical timing that limits the clock period is the CP to  $\overline{TC}$  delay of the first stage plus the  $\overline{CEP}$  to CP setup time of the last stage. The  $\overline{TC}$  output is subject to decoding spikes due to internal race conditions and is therefore not recommended for use as a clock or asynchronous reset for flip-flops, registers or counters.

Logic Equations: Count Enable =  $\overline{CEP} \cdot \overline{CET} \cdot \overline{PE}$   
 $TC = Q_0 \cdot Q_1 \cdot Q_2 \cdot Q_3 \cdot CET$

## Mode Select Table

$\overline{PE}$	CET	CEP	Action on the Rising Clock Edge ( $\nearrow$ )
X	X	X	Reset (Clear)
L	X	X	Load ( $P_n \rightarrow Q_n$ )
H	H	H	Count (Increment)
H	L	X	No Change (Hold)
H	X	L	No Change (Hold)

H = HIGH Voltage Level  
 L = LOW Voltage Level  
 X = Immaterial

## State Diagram

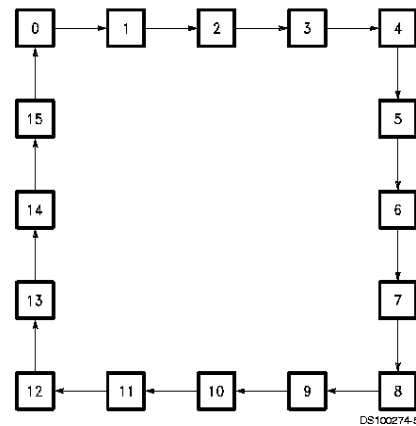

## State Diagram (Continued)

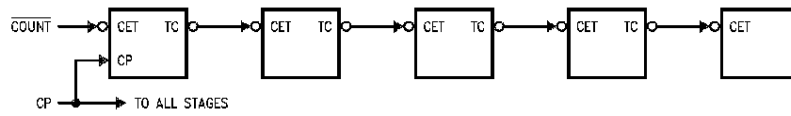

DS100274-8

**FIGURE 1. Multistage Counter with Ripple Carry**

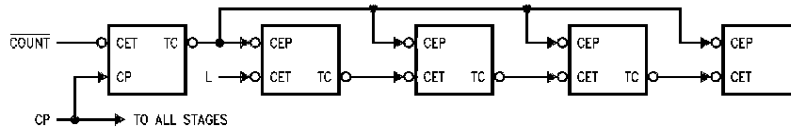

DS100274-9

**FIGURE 2. Multistage Counter with Lookahead Carry**

# Block Diagram

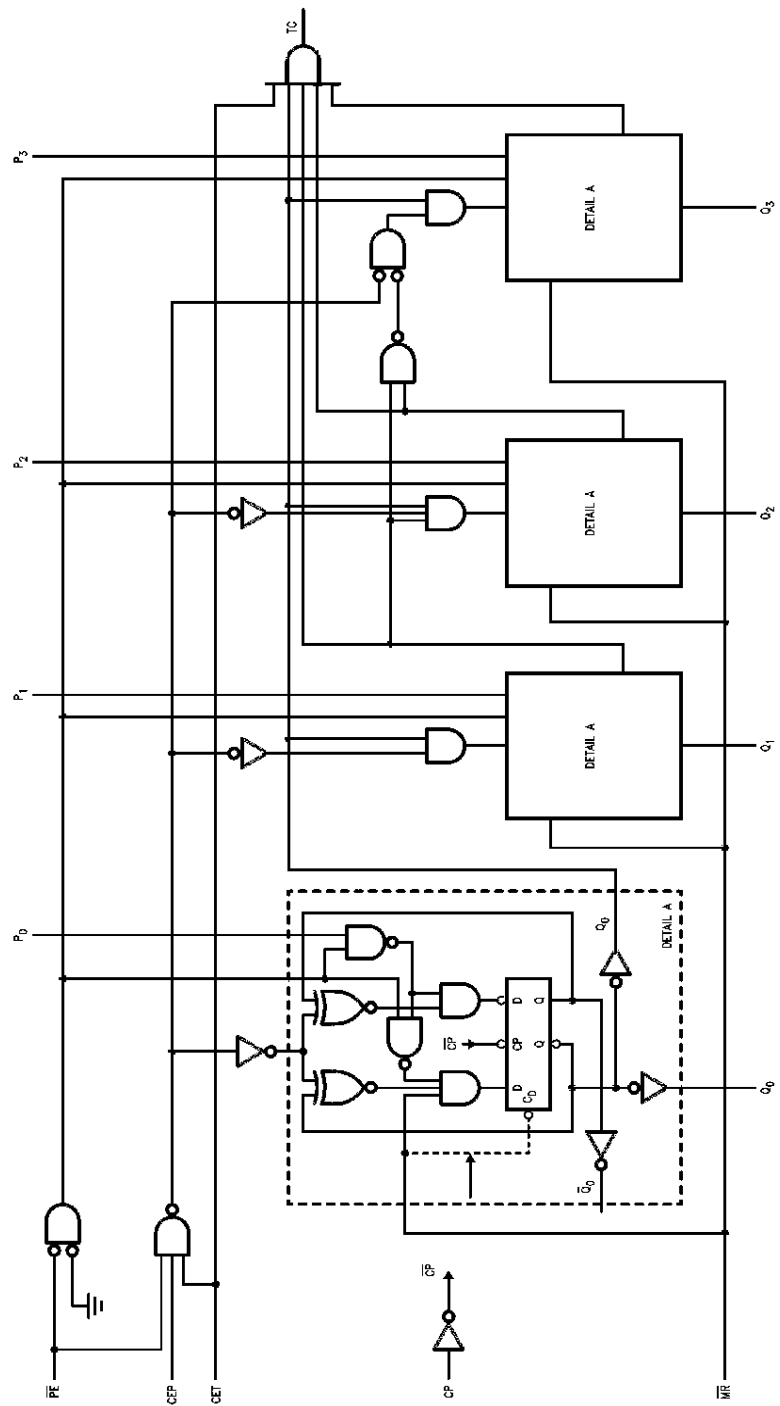

DS1002746

Please note that this diagram is provided only for the understanding of logic operations and should not be used to estimate propagation delays.

## Absolute Maximum Ratings (Note 1)

If Military/Aerospace specified devices are required, please contact the National Semiconductor Sales Office/Distributors for availability and specifications.

Supply Voltage ( $V_{CC}$ )	-0.5V to +7.0V
DC Input Diode Current ( $I_{IK}$ )	
$V_I = -0.5V$	-20 mA
$V_I = V_{CC} + 0.5V$	+20 mA
DC Input Voltage ( $V_I$ )	-0.5V to $V_{CC} + 0.5V$
DC Output Diode Current ( $I_{OK}$ )	
$V_O = -0.5V$	-20 mA
$V_O = V_{CC} + 0.5V$	+20 mA
DC Output Voltage ( $V_O$ )	-0.5V to $V_{CC} + 0.5V$
DC Output Source or Sink Current ( $I_O$ )	±50 mA
DC $V_{CC}$ or Ground Current per Output Pin ( $I_{CC}$ or $I_{GND}$ )	±50 mA
Storage Temperature ( $T_{STG}$ )	-65°C to +150°C
Junction Temperature ( $T_J$ )	
CDIP	175°C

## Recommended Operating Conditions

Supply Voltage ( $V_{CC}$ )	
'AC	2.0V to 6.0V
'ACT	4.5V to 5.5V
Input Voltage ( $V_I$ )	0V to $V_{CC}$
Output Voltage ( $V_O$ )	0V to $V_{CC}$
Operating Temperature ( $T_A$ )	
54AC/ACT	-55°C to +125°C
Minimum Input Edge Rate ( $\Delta V/\Delta t$ )	
'AC Devices	
$V_{IN}$ from 30% to 70% of $V_{CC}$	
$V_{CC}$ @ 3.3V, 4.5V, 5.5V	125 mV/ns
Minimum Input Edge Rate ( $\Delta V/\Delta t$ )	
'ACT Devices	
$V_{IN}$ from 0.8V to 2.0V	
$V_{CC}$ @ 4.5V, 5.5V	125 mV/ns

**Note 1:** Absolute maximum ratings are those values beyond which damage to the device may occur. The databook specifications should be met, without exception, to ensure that the system design is reliable over its power supply, temperature, and output/input loading variables. National does not recommend operation of FACT™ circuits outside databook specifications.

## DC Characteristics for 'AC Family Devices

Symbol	Parameter	$V_{CC}$ (V)	54AC		Units	Conditions
			$T_A =$ -55°C to +125°C			
			Guaranteed Limits			
$V_{IH}$	Minimum High Level Input Voltage	3.0	2.1	V	$V_{OUT} = 0.1V$ or $V_{CC} - 0.1V$	
		4.5	3.15			
		5.5	3.85			
$V_{IL}$	Maximum Low Level Input Voltage	3.0	0.9	V	$V_{OUT} = 0.1V$ or $V_{CC} - 0.1V$	
		4.5	1.35			
		5.5	1.65			
$V_{OH}$	Minimum High Level Output Voltage	3.0	2.9	V	$I_{OUT} = -50 \mu A$	
		4.5	4.4			
		5.5	5.4			
$V_{OL}$	Maximum Low Level Output Voltage	3.0	2.4	V	(Note 2) $V_{IN} = V_{IL}$ or $V_{IH}$ $I_{OH} = -12 mA$ $I_{OH} = -24 mA$ $I_{OH} = -24 mA$	
		4.5	3.7			
		5.5	4.7			
$V_{OL}$	Maximum Low Level Output Voltage	3.0	0.1	V	$I_{OUT} = 50 \mu A$	
		4.5	0.1			
		5.5	0.1			
$V_{OL}$	Maximum Low Level Output Voltage	3.0	0.5	V	(Note 2) $V_{IN} = V_{IL}$ or $V_{IH}$ $I_{OL} = 12 mA$ $I_{OL} = 24 mA$ $I_{OL} = 24 mA$	
		4.5	0.5			
		5.5	0.5			
$I_{IN}$	Maximum Input Leakage Current	5.5	±1.0	μA	$V_I = V_{CC}, GND$	
$I_{OLD}$	Minimum Dynamic Output Current (Note 3)	5.5	50	mA	$V_{OLD} = 1.65V$ Max	
$I_{OHD}$	Maximum Dynamic Output Current (Note 3)	5.5	-50	mA	$V_{OHD} = 3.85V$ Min	
$I_{CC}$	Maximum Quiescent	5.5	160	μA	$V_{IN} = V_{CC}$	

## DC Characteristics for 'AC Family Devices (Continued)

Symbol	Parameter	V <sub>CC</sub> (V)	54AC	Units	Conditions
			T <sub>A</sub> =		
			Guaranteed Limits		
	Supply Current				or GND

**Note 2:** All outputs loaded; thresholds on input associated with output under test.

**Note 3:** Maximum test duration 2.0 ms, one output loaded at a time.

**Note 4:** I<sub>IN</sub> and I<sub>CC</sub> @ 3.0V are guaranteed to be less than or equal to the respective limit @ 5.5V V<sub>CC</sub>.  
I<sub>CC</sub> for 54AC @ 25°C is identical to 74AC @ 25°C.

## DC Characteristics for 'ACT Family Devices

Symbol	Parameter	V <sub>CC</sub> (V)	54ACT	Units	Conditions	
			T <sub>A</sub> =			
			Guaranteed Limits			
V <sub>IH</sub>	Minimum High Level Input Voltage (Note 7)	4.5	3.0	V	V <sub>OUT</sub> = 0.1V or V <sub>CC</sub> - 0.1V	
		5.5	3.0			
V <sub>IL</sub>	Maximum Low Level Input Voltage	4.5	0.8	V	V <sub>OUT</sub> = 0.1V or V <sub>CC</sub> - 0.1V	
		5.5	0.8			
V <sub>OH</sub>	Minimum High Level Output Voltage	4.5	4.4	V	I <sub>OUT</sub> = -50 μA	
		5.5	5.4			
			4.5	3.70	V	(Note 5) V <sub>IN</sub> = V <sub>IL</sub> or 3.0V I <sub>OH</sub> = -24 mA I <sub>OH</sub> = -24 mA
			5.5	4.70		
V <sub>OL</sub>	Maximum Low Level Output Voltage	4.5	0.1	V	I <sub>OUT</sub> = 50 μA	
		5.5	0.1			
			4.5	0.50	V	(Note 5) V <sub>IN</sub> = V <sub>IL</sub> or V <sub>IH</sub> I <sub>OL</sub> = 24 mA I <sub>OL</sub> = 24 mA
		5.5	0.50			
I <sub>IN</sub>	Maximum Input Leakage Current	5.5	±1.0	μA	V <sub>I</sub> = V <sub>CC</sub> , GND	
I <sub>CC(T)</sub>	Maximum I <sub>CC</sub> /Input	5.5	1.6	mA	V <sub>I</sub> = V <sub>CC</sub> - 2.1V	
I <sub>OLD</sub>	Minimum Dynamic Output Current (Note 6)	5.5	50	mA	V <sub>OLD</sub> = 1.65V Max	
I <sub>OHD</sub>		5.5	-50	mA	V <sub>OHD</sub> = 3.85V Min	
I <sub>CC</sub>	Maximum Quiescent Supply Current	5.5	160	μA	V <sub>IN</sub> = V <sub>CC</sub> or GND	

**Note 5:** All outputs loaded; thresholds on input associated with output under test.

**Note 6:** Maximum test duration 2.0 ms, one output loaded at a time.

**Note 7:** For dynamic operation, a V<sub>IH</sub> level between 2.0 and 3.0V may be recognized by this device as a high logic level input. For static operation, a V<sub>IH</sub> ≥ 2.0V will be recognized by this device as a high logic level input. Users are cautioned to verify that this will not affect their system.

## AC Electrical Characteristics

Symbol	Parameter	V <sub>CC</sub> (V) (Note 8)	54AC		Units	Fig. No.
			T <sub>A</sub> = -55°C to +125°C C <sub>L</sub> = 50 pF			
			Min	Max		
f <sub>max</sub>	Maximum Count Frequency	3.3	55		MHz	
		5.0	80			
t <sub>PLH</sub>	Propagation Delay CP to Q <sub>n</sub> ( $\overline{PE}$ Input HIGH or LOW)	3.3	1.0	14.0	ns	
		5.0	1.0	10.0		
t <sub>PHL</sub>	Propagation Delay CP to Q <sub>n</sub> ( $\overline{PE}$ Input HIGH or LOW)	3.3	1.0	14.0	ns	
		5.0	1.0	10.0		
t <sub>PLH</sub>	Propagation Delay CP to TC	3.3	3.0	18.0	ns	
		5.0	3.0	13.0		
t <sub>PHL</sub>	Propagation Delay CP to TC	3.3	1.0	17.5	ns	
		5.0	1.0	13.0		
t <sub>PLH</sub>	Propagation Delay CET to TC	3.3	1.0	13.0	ns	
		5.0	1.0	8.5		
t <sub>PHL</sub>	Propagation Delay CET to TC	3.3	1.0	13.5	ns	
		5.0	1.0	10.5		
t <sub>PHL</sub>	Propagation Delay $\overline{MR}$ to Q <sub>n</sub>	3.3	1.0	14.5	ns	
		5.0	1.0	10.5		
t <sub>PHL</sub>	Propagation Delay $\overline{MR}$ to TC	3.3	1.0	18.5	ns	
		5.0	1.0	14.0		

**Note 8:** Voltage Range 3.3 is 3.3V ±0.3V  
Range 5.0 is 5.0V ±0.5V

## AC Operating Requirements

Symbol	Parameter	V <sub>CC</sub> (V) (Note 9)	54AC		Units	Fig. No.
			T <sub>A</sub> = -55°C to +125°C C <sub>L</sub> = 50 pF			
			Guaranteed Minimum			
t <sub>s</sub>	Setup Time, HIGH or LOW P <sub>n</sub> to CP	3.3	16.0		ns	
		5.0	10.5			
t <sub>h</sub>	Hold Time, HIGH or LOW P <sub>n</sub> to CP	3.3	0.5		ns	
		5.0	1.5			
t <sub>s</sub>	Setup Time, HIGH or LOW $\overline{PE}$ to CP	3.3	15.0		ns	
		5.0	10.5			
t <sub>h</sub>	Hold Time, HIGH or LOW $\overline{PE}$ to CP	3.3	-1.0		ns	
		5.0	0.0			
t <sub>s</sub>	Setup Time, HIGH or LOW CEP or CET to CP	3.3	7.5		ns	
		5.0	5.5			
t <sub>h</sub>	Hold Time, HIGH or LOW CEP or CET to CP	3.3	2.0		ns	
		5.0	2.0			
t <sub>w</sub>	Clock Pulse Width (Load) HIGH or LOW	3.3	5.0		ns	
		5.0	5.0			
t <sub>w</sub>	Clock Pulse Width (Count) HIGH or LOW	3.3	5.0		ns	
		5.0	5.0			
t <sub>w</sub>	$\overline{MR}$ Pulse Width, LOW	3.3	5.0		ns	
		5.0	5.0			

### AC Operating Requirements (Continued)

Symbol	Parameter	V <sub>CC</sub> (V) (Note 9)	54AC		Units	Fig. No.
			T <sub>A</sub> = -55°C to +125°C C <sub>L</sub> = 50 pF			
			Guaranteed Minimum			
t <sub>rec</sub>	Recovery Time MR to CP		1.5		ns	
			2.0			

**Note 9:** Voltage Range 3.3 is 3.3V ±0.3V  
Voltage Range 5.0 is 5.0V ±0.5V

### AC Electrical Characteristics

Symbol	Parameter	V <sub>CC</sub> (V) (Note 10)	54ACT		Units	Fig. No.
			T <sub>A</sub> = -55°C to +125°C C <sub>L</sub> = 50 pF			
			Min	Max		
f <sub>max</sub>	Maximum Count Frequency	5.0	85		MHz	
t <sub>PLH</sub>	Propagation Delay CP to Q <sub>n</sub> (PE Input HIGH or LOW)	5.0	1.0	10.5	ns	
t <sub>PHL</sub>	Propagation Delay CP to Q <sub>n</sub> (PE Input HIGH or LOW)	5.0	1.0	10.5	ns	
t <sub>PLH</sub>	Propagation Delay CP to TC	5.0	1.0	14.0	ns	
t <sub>PHL</sub>	Propagation Delay CP to TC	5.0	1.0	12.5	ns	
t <sub>PLH</sub>	Propagation Delay CET to TC	5.0	1.0	9.5	ns	
t <sub>PHL</sub>	Propagation Delay CET to TC	5.0	1.0	9.5	ns	
t <sub>PHL</sub>	Propagation Delay MR to Q <sub>n</sub>	5.0	1.0	10.0	ns	
t <sub>PHL</sub>	Propagation Delay MR to TC	5.0	1.0	11.5	ns	

**Note 10:** Voltage Range 5.0 is 5.0V ±0.5V

### AC Operating Requirements

Symbol	Parameter	V <sub>CC</sub> (V) (Note 11)	54ACT		Units	Fig. No.
			T <sub>A</sub> = -55°C to +125°C C <sub>L</sub> = 50 pF			
			Guaranteed Minimum			
t <sub>s</sub>	Setup Time, HIGH or LOW P <sub>n</sub> to CP	5.0	13.0		ns	
t <sub>h</sub>	Hold Time, HIGH or LOW P <sub>n</sub> to CP	5.0	0		ns	
t <sub>s</sub>	Setup Time, HIGH or LOW PE to CP	5.0	11.0		ns	



## AC Operating Requirements (Continued)

Symbol	Parameter	V <sub>CC</sub> (V) (Note 11)	54ACT	Units	Fig. No.
			T <sub>A</sub> = -55°C to +125°C C <sub>L</sub> = 50 pF		
			Guaranteed Minimum		
t <sub>h</sub>	Hold Time, HIGH or LOW PE to CP	5.0	0	ns	
t <sub>s</sub>	Setup Time, HIGH or LOW CEP or CET to CP	5.0	7.0	ns	
t <sub>h</sub>	Hold Time, HIGH or LOW CEP or CET to CP	5.0	0.5	ns	
t <sub>w</sub>	Clock Pulse Width, (Load) HIGH or LOW	5.0	5.0	ns	
t <sub>w</sub>	Clock Pulse Width, (Count) HIGH or LOW	5.0	5.0	ns	
t <sub>w</sub>	MR Pulse Width, LOW	5.0	6.5	ns	
t <sub>rec</sub>	Recovery Time MR to CP	5.0	0.5	ns	

Note 11: Voltage Range 5.0 is 5.0V ±0.5V

## Capacitance

Symbol	Parameter	Typ	Units	Conditions
C <sub>IN</sub>	Input Capacitance	4.5	pF	V <sub>CC</sub> = OPEN
C <sub>PD</sub>	Power Dissipation Capacitance	45.0	pF	V <sub>CC</sub> = 5.0V

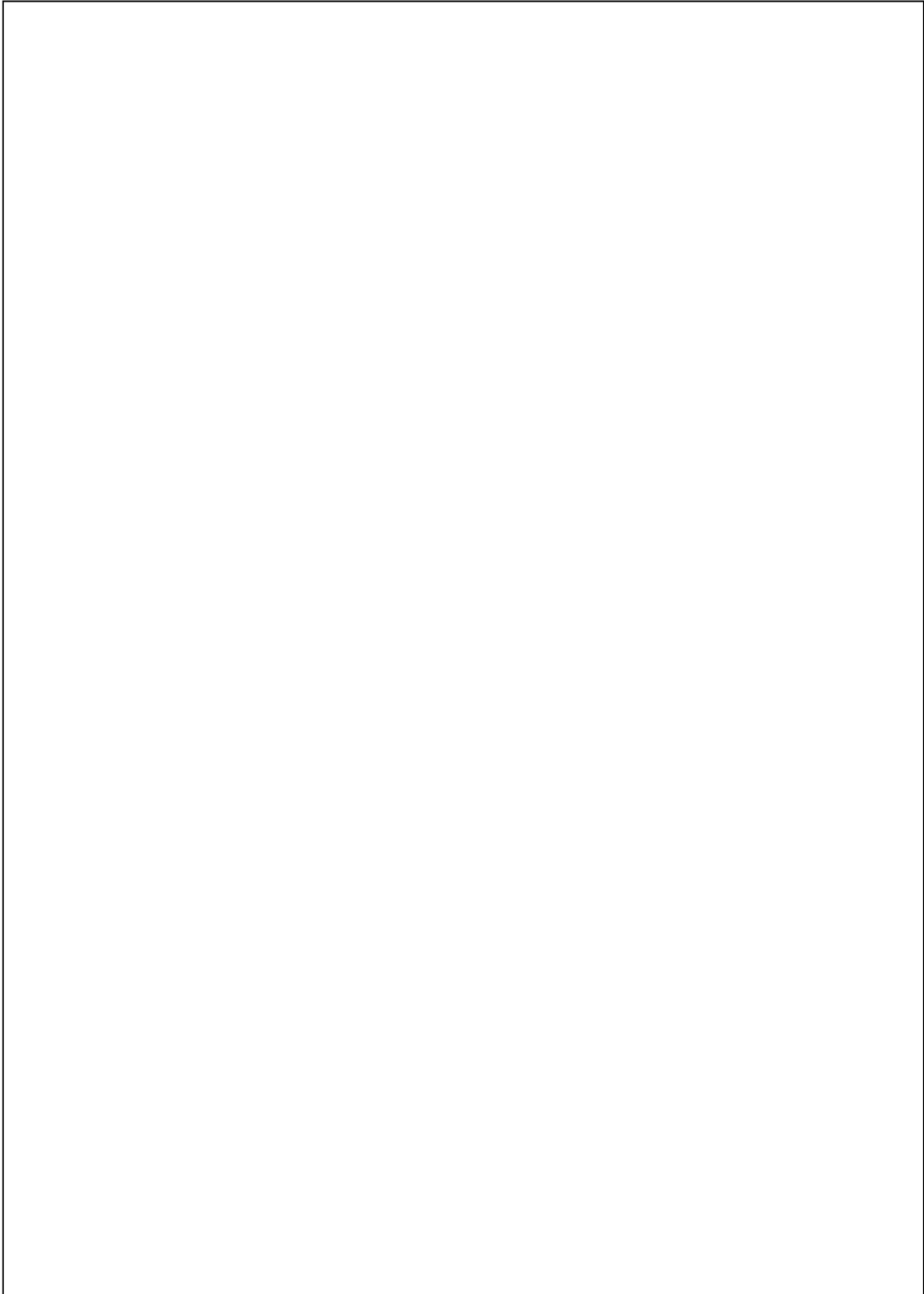

**Physical Dimensions** inches (millimeters) unless otherwise noted

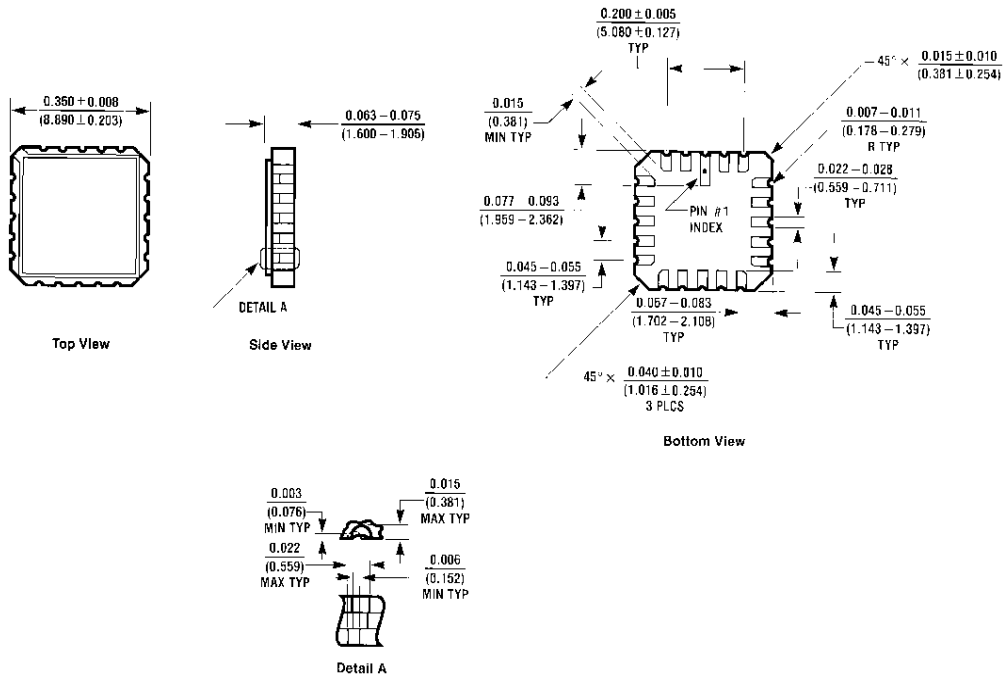

**20 Terminal Ceramic Leadless Chip Carrier (L)**  
 NS Package Number E20A

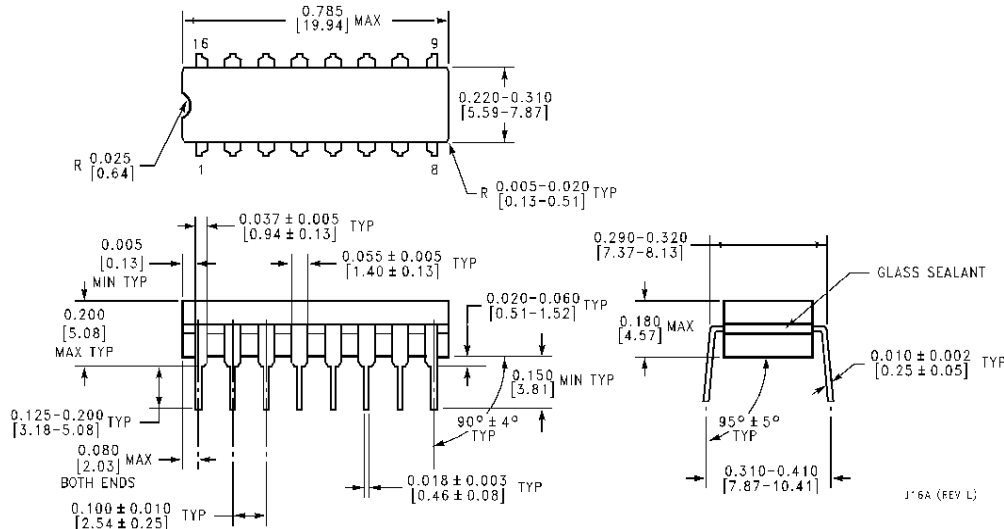

**16 Lead Ceramic Dual-In-Line Package (D)**  
 NS Package Number J16A

**Physical Dimensions** inches (millimeters) unless otherwise noted (Continued)

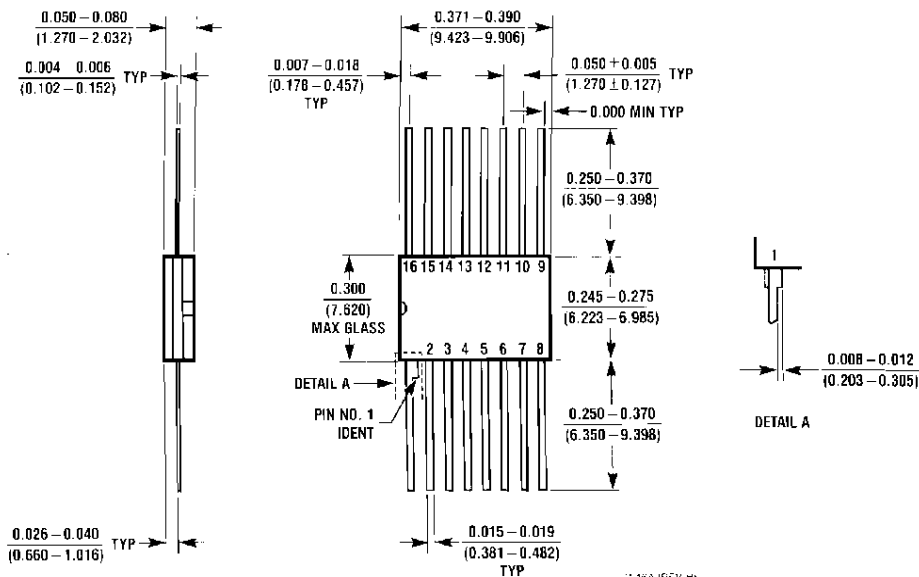

**16 Lead Ceramic Flatpak (F)  
NS Package Number W16A**

**LIFE SUPPORT POLICY**

NATIONAL'S PRODUCTS ARE NOT AUTHORIZED FOR USE AS CRITICAL COMPONENTS IN LIFE SUPPORT DEVICES OR SYSTEMS WITHOUT THE EXPRESS WRITTEN APPROVAL OF THE PRESIDENT OF NATIONAL SEMICONDUCTOR CORPORATION. As used herein:

1. Life support devices or systems are devices or systems which, (a) are intended for surgical implant into the body, or (b) support or sustain life, and whose failure to perform when properly used in accordance with instructions for use provided in the labeling, can be reasonably expected to result in a significant injury to the user.
2. A critical component in any component of a life support device or system whose failure to perform can be reasonably expected to cause the failure of the life support device or system, or to affect its safety or effectiveness.



**National Semiconductor Corporation**  
Americas  
Tel: 1-800-272-9959  
Fax: 1-800-737-7018  
Email: support@nsc.com

**National Semiconductor Europe**  
Fax: +49 (0) 1 80-530 85 86  
Email: europe.support@nsc.com  
Deutsch Tel: +49 (0) 1 80-530 85 85  
English Tel: +49 (0) 1 80-532 78 32  
Français Tel: +49 (0) 1 80-532 93 58  
Italiano Tel: +49 (0) 1 80-534 16 80

**National Semiconductor Asia Pacific Customer Response Group**  
Tel: 65-2544466  
Fax: 65-2504466  
Email: sea.support@nsc.com

**National Semiconductor Japan Ltd.**  
Tel: 81-3-5620-6175  
Fax: 81-3-5620-6179

www.national.com