



CY74FCT2541T

8-Bit Buffer/Line Driver

Features

- Function and pinout compatible with FCT and F logic
- FCT-C speed at 4.1 ns max.
FCT-A speed at 4.8 ns max.
- 25Ω output series to reduce transmission line reflection noise
- Reduced V_{OH} (typically = 3.3V) versions of equivalent FCT functions
- Edge-rate control circuitry for significantly improved noise characteristics
- Power-off disable feature
- ESD > 2000V
- Matched rise and fall times
- Fully compatible with TTL input and output logic levels
- Sink current 12 mA
 Source current 15 mA

- Extended commercial temp. range of -40°C to +85°C
- Three-state outputs

Functional Description

The FCT2541T is an octal buffer and line driver designed to be employed as a memory address driver, clock driver, and bus-oriented transmitter/receiver. On-chip termination resistors have been added to the outputs to reduce system noise caused by reflections. The FCT2541T can be used to replace the FCT541T to reduce noise in an existing design. The speed of the FCT2541T is comparable to bipolar logic counterparts while reducing power dissipation. The input and output voltage levels allow direct interface with TTL and CMOS devices without external components.

The outputs are designed with a power-off disable feature to allow for live insertion of boards.

Logic Block Diagram

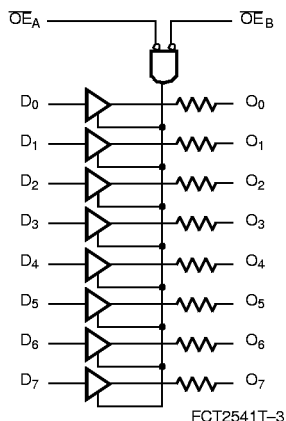

Pin Configurations

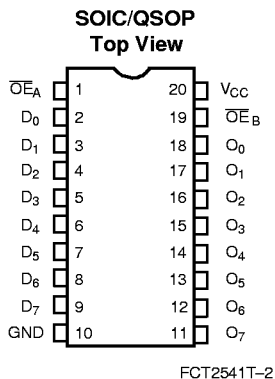

Function Table^[1]

Inputs			Output
OE _A	OE _B	D	
L	L	L	L
L	L	H	H
H	H	X	Z

Note:

1. H = HIGH Voltage Level
L = LOW Voltage Level
X = Don't Care
Z = High Impedance



Maximum Ratings^[2,3]

(Above which the useful life may be impaired. For user guidelines, not tested.)

- Storage Temperature -65°C to +150°C
- Ambient Temperature with Power Applied -65°C to +135°C
- Supply Voltage to Ground Potential -0.5V to +7.0V
- DC Input Voltage -0.5V to +7.0V
- DC Output Voltage -0.5V to +7.0V

- DC Output Current (Maximum Sink Current/Pin) 120 mA
- Power Dissipation 0.5W
- Static Discharge Voltage >2001V (per MIL-STD-883, Method 3015)

Operating Range

Range	Ambient Temperature	V _{CC}
Commercial	-40°C to +85°C	5V ± 5%

Electrical Characteristics Over the Operating Range

Parameter	Description	Test Conditions	Min.	Typ. ^[5]	Max.	Unit
V _{OH}	Output HIGH Voltage	V _{CC} = Min., I _{OH} = -15 mA	2.4	3.3		V
V _{OL}	Output LOW Voltage	V _{CC} = Min., I _{OL} = 12 mA		0.3	0.55	V
R _{OUT}	Output Resistance	V _{CC} = Min., I _{OL} = 12 mA	20	25	40	Ω
V _{IH}	Input HIGH Voltage		2.0			V
V _{IL}	Input LOW Voltage				0.8	V
V _H	Hysteresis ^[6]	All inputs		0.2		V
V _{IK}	Input Clamp Diode Voltage	V _{CC} = Min., I _{IN} = -18 mA		-0.7	-1.2	V
I _I	Input HIGH Current	V _{CC} = Max., V _{IN} = V _{CC}			5	μA
I _{IH}	Input HIGH Current	V _{CC} = Max., V _{IN} = 2.7V			±1	μA
I _{IL}	Input LOW Current	V _{CC} = Max., V _{IN} = 0.5V			±1	μA
I _{OZH}	Off State HIGH-Level Output Current	V _{CC} = Max., V _{OUT} = 2.7V			15	μA
I _{OZL}	Off State LOW-Level Output Current	V _{CC} = Max., V _{OUT} = 0.5V			-15	μA
I _{OS}	Output Short Circuit Current ^[7]	V _{CC} = Max., V _{OUT} = 0.0V	-60	-120	-225	mA
I _{OFF}	Power-Off Disable	V _{CC} = 0V, V _{OUT} = 4.5V			±1	μA

Capacitance^[6]

Parameter	Description	Typ. ^[5]	Max.	Unit
C _{IN}	Input Capacitance	5	10	pF
C _{OUT}	Output Capacitance	9	12	pF

Notes:

2. Unless otherwise noted, these limits are over the operating free-air temperature range.
3. Unused inputs must always be connected to an appropriate logic voltage level, preferably either V_{CC} or ground.
4. T_A is the "instant on" case temperature.
5. Typical values are at V_{CC}=5.0V, T_A=+25°C ambient.
6. This parameter is guaranteed but not tested.
7. Not more than one output should be shorted at a time. Duration of short should not exceed one second. The use of high-speed test apparatus and/or sample and hold techniques are preferable in order to minimize internal chip heating and more accurately reflect operational values. Otherwise prolonged shorting of a high output may raise the chip temperature well above normal and thereby cause invalid readings in other parametric tests. In any sequence of parameter tests, I_{OS} tests should be performed last.

Power Supply Characteristics

Parameter	Description	Test Conditions	Typ. ^[5]	Max.	Unit
I_{CC}	Quiescent Power Supply Current	$V_{CC} = \text{Max.}, V_{IN} \leq 0.2V,$ $V_{IN} \geq V_{CC} - 0.2V$	0.1	0.2	mA
ΔI_{CC}	Quiescent Power Supply Current (TTL inputs)	$V_{CC} = \text{Max.}, V_{IN} = 3.4V,$ ^[8] $f_1 = 0, \text{Outputs Open}$	0.5	2.0	mA
I_{CCD}	Dynamic Power Supply Current ^[9]	$V_{CC} = \text{Max.}, 50\% \text{ Duty Cycle, Outputs Open,}$ One Bit Toggling, $\overline{OE}_A = \overline{OE}_B = \text{GND}, V_{IN} \leq 0.2V \text{ or}$ $V_{IN} \geq V_{CC} - 0.2V$	0.06	0.12	mA/ MHz
I_C	Total Power Supply Current ^[10]	$V_{CC} = \text{Max.}, 50\% \text{ Duty Cycle, Outputs Open,}$ One Bit Toggling at $f_1 = 10 \text{ MHz},$ $\overline{OE}_A = \overline{OE}_B = \text{GND}, V_{IN} \leq 0.2V \text{ or}$ $V_{IN} \geq V_{CC} - 0.2V$	0.7	1.4	mA
		$V_{CC} = \text{Max.}, 50\% \text{ Duty Cycle, Outputs Open,}$ One Bit Toggling at $f_1 = 10 \text{ MHz},$ $\overline{OE}_A = \overline{OE}_B = \text{GND}, V_{IN} = 3.4V \text{ or } V_{IN} = \text{GND}$	1.0	2.4	mA
		$V_{CC} = \text{Max.}, 50\% \text{ Duty Cycle, Outputs Open,}$ Eight Bits Toggling at $f_1 = 2.5 \text{ MHz},$ $\overline{OE}_A = \overline{OE}_B = \text{GND}, V_{IN} \leq 0.2V \text{ or } V_{IN} \geq V_{CC} - 0.2V$	1.3	2.6 ^[11]	mA
		$V_{CC} = \text{Max.}, 50\% \text{ Duty Cycle, Outputs Open,}$ Eight Bits Toggling at $f_1 = 2.5 \text{ MHz},$ $\overline{OE}_A = \overline{OE}_B = \text{GND}, V_{IN} = 3.4V \text{ or } V_{IN} = \text{GND}$	3.3	10.6 ^[11]	mA

Switching Characteristics Over the Operating Range^[12]

Parameter	Description	CY74FCT2541T		CY74FCT2541AT		CY74FCT2541AT		Unit	Fig. No. ^[13]
		Min.	Max.	Min.	Max.	Min.	Max.		
t_{PLH} t_{PHL}	Propagation Delay Data to Output	1.5	8.0	1.5	4.8	1.5	4.1	ns	1, 3
t_{PZH} t_{PZL}	Output Enable Time	1.5	10.0	1.5	6.2	1.5	5.8	ns	1, 7, 8
t_{PHZ} t_{PLZ}	Output Disable Time	1.5	9.5	1.5	5.6	1.5	5.2	ns	1, 7, 8

Notes:

8. Per TTL driven input ($V_{IN} = 3.4V$); all other inputs at V_{CC} or GND.
9. This parameter is not directly testable, but is derived for use in Total Power Supply calculations.
10. $I_C = I_{\text{QUIESCENT}} + I_{\text{INPUTS}} + I_{\text{DYNAMIC}}$
 $I_C = I_{CC} + \Delta I_{CC} D_H N_T + I_{CCD} (f_0/2 + f_1 N_1)$
 I_{CC} = Quiescent Current with CMOS input levels
 ΔI_{CC} = Power Supply Current for a TTL HIGH input ($V_{IN} = 3.4V$)
 D_H = Duty Cycle for TTL inputs HIGH
 N_T = Number of TTL inputs at D_H
 I_{CCD} = Dynamic Current caused by an input transition pair (HLH or LHL)
 f_0 = Clock frequency for registered devices, otherwise zero
 f_1 = Input signal frequency
 N_1 = Number of inputs changing at f_1
 All currents are in milliamps and all frequencies are in megahertz.
11. Values for these conditions are examples of the I_{CC} formula. These limits are guaranteed but not tested.
12. Minimum limits are guaranteed but not tested on Propagation Delays.
13. See "Parameter Measurement Information" in the General Information section.



Ordering Information

Speed (ns)	Ordering Code	Package Name	Package Type	Operating Range
4.1	CY74FCT2541CTQC	Q5	20-Lead (150-Mil) QSOP	Commercial
	CY74FCT2541CTSOC	S5	20-Lead (300-Mil) Molded SOIC	
4.8	CY74FCT2541ATQC	Q5	20-Lead (150-Mil) QSOP	Commercial
	CY74FCT2541ATSOC	S5	20-Lead (300-Mil) Molded SOIC	
8.0	CY74FCT2541TQC	Q5	20-Lead (150-Mil) QSOP	Commercial
	CY74FCT2541TSOC	S5	20-Lead (300-Mil) Molded SOIC	

Document #: 38-00342-A

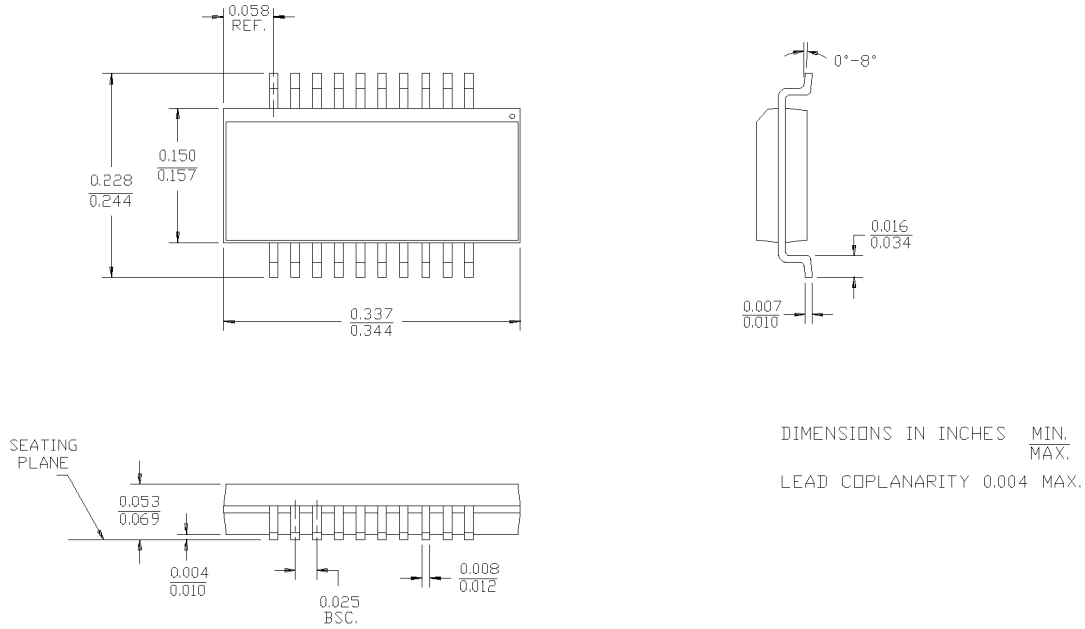
Package Diagrams
20-Lead Quarter Size Outline Q5

20-Lead (300-Mil) Molded SOIC S5
