



CY74FCT16827T CY74FCT162827T

20-Bit Buffer

Features

- Low power, pin compatible replacement for ABT functions
- FCT-E speed at 3.2 ns
- Power-off disable outputs permits live insertion
- Edge-rate control circuitry for significantly improved noise characteristics
- Typical output skew < 250 ps
- ESD > 2000V
- TSSOP (19.6-mil pitch) and SSOP (25-mil pitch) packages
- Industrial temperature range of -40°C to +85°C
- $V_{CC} = 5V \pm 10\%$

CY74FCT16827T Features:

- 64 mA sink current, 32 mA source current
- Typical V_{OLP} (ground bounce) < 1.0V at $V_{CC} = 5V$, $T_A = 25^\circ C$

CY74FCT162827T Features:

- Balanced 24 mA output drivers
- Reduced system switching noise
- Typical V_{OLP} (ground bounce) < 0.6V at $V_{CC} = 5V$, $T_A = 25^\circ C$

Functional Description

The CY74FCT16827T 20-bit buffer/line driver and the CY74FCT162827T 20-bit buffer/line driver provide high-performance bus interface buffering for wide data/address paths or buses carrying parity. These parts can be used as a single 20-bit buffer or two 10-bit buffers. Each 10-bit buffer has a pair of NANDed OE for increased flexibility. The outputs are designed with a power-off disable feature to allow for live insertion of boards.

The CY74FCT16827T is ideally suited for driving high-capacitance loads and low-impedance backplanes.

The CY74FCT162827T has 24-mA balanced output drivers with current-limiting resistors in the outputs. This reduces the need for external terminating resistors and provides for minimal undershoot and reduced ground bounce. The CY74FCT162827T is ideal for driving transmission lines.

Logic Block Diagrams

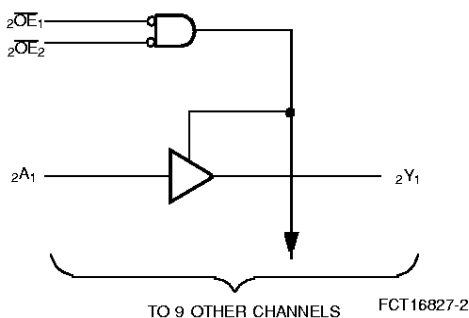
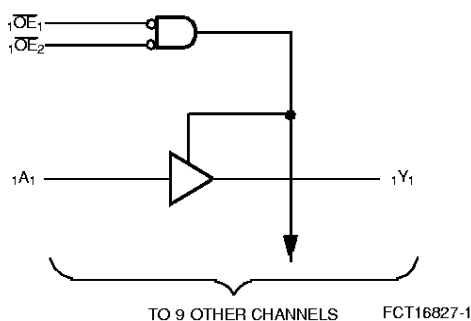

Pin Configuration

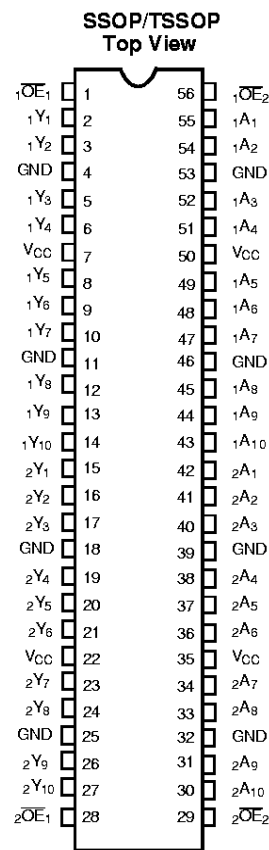

FCT16827-3



Pin Description

Name	Description
\overline{OE}	Output Enable Inputs (Active LOW)
A	Data Inputs
Y	Three-State Outputs

Function Table^[1]

Inputs			Outputs
\overline{OE}_1	\overline{OE}_2	A	Y
L	L	L	L
L	L	H	H
H	X	X	Z
X	H	X	Z

Maximum Ratings^[2, 3]

(Above which the useful life may be impaired. For user guidelines, not tested.)

Storage Temperature.....	-55°C to +125°C
Ambient Temperature with Power Applied.....	-55°C to +125°C
DC Input Voltage	-0.5V to +7.0V
DC Output Voltage	-0.5V to +7.0V
DC Output Current (Maximum Sink Current/Pin)	-60 to +120 mA
Power Dissipation	1.0W
Static Discharge Voltage	>2001V (per MIL-STD-883, Method 3015)

Operating Range

Range	Ambient Temperature	V _{CC}
Industrial	-40°C to +85°C	5V ± 10%

Electrical Characteristics Over the Operating Range

Parameter	Description	Test Conditions	Min.	Typ. ^[4]	Max.	Unit
V _{IH}	Input HIGH Voltage		2.0			V
V _{IL}	Input LOW Voltage				0.8	V
V _H	Input Hysteresis ^[5]			100		mV
V _{IK}	Input Clamp Diode Voltage	V _{CC} =Min., I _{IN} =-18 mA		-0.7	-1.2	V
I _{IH}	Input HIGH Current	V _{CC} =Max., V _I =V _{CC}			±1	µA
I _{IL}	Input LOW Current	V _{CC} =Max., V _I =GND			±1	µA
I _{OZH}	High Impedance Output Current (Three-State Output pins)	V _{CC} =Max., V _{OUT} =2.7V			±1	µA
I _{OZL}	High Impedance Output Current (Three-State Output pins)	V _{CC} =Max., V _{OUT} =0.5V			±1	µA
I _{OS}	Short Circuit Current ^[6]	V _{CC} =Max., V _{OUT} =GND	-80	-140	-200	mA
I _O	Output Drive Current ^[6]	V _{CC} =Max., V _{OUT} =2.5V	-50		-180	mA
I _{OFF}	Power-Off Disable	V _{CC} =0V, V _{OUT} ≤4.5V ^[7]			±1	µA

Output Drive Characteristics for CY74FCT16827T

Parameter	Description	Test Conditions	Min.	Typ. ^[4]	Max.	Unit
V _{OH}	Output HIGH Voltage	V _{CC} =Min., I _{OH} =-3 mA	2.5	3.5		V
		V _{CC} =Min., I _{OH} =-15 mA	2.4	3.5		
		V _{CC} =Min., I _{OH} =-32 mA	2.0	3.0		
V _{OL}	Output LOW Voltage	V _{CC} =Min., I _{OL} =64 mA		0.2	0.55	V

1. H = HIGH Voltage Level. L = LOW Voltage Level. X = Don't Care. Z = HIGH Impedance.
2. Operation beyond the limits set forth may impair the useful life of the device. Unless noted, these limits are over the operating free-air temperature range.
3. Unused inputs must always be connected to an appropriate logic voltage level, preferably either V_{CC} or ground.
4. Typical values are at V_{CC}= 5.0V, T_A= +25°C ambient.
5. This parameter is guaranteed but not tested.
6. Not more than one output should be shorted at a time. Duration of short should not exceed one second. The use of high-speed test apparatus and/or sample and hold techniques are preferable in order to minimize internal chip heating and more accurately reflect operational values. Otherwise prolonged shorting of a high output may raise the chip temperature well above normal and thereby cause invalid readings in other parametric tests. In any sequence of parameter tests, I_{OS} tests should be performed last.
7. Tested at +25°C.



Output Drive Characteristics for CY74FCT162827T

Parameter	Description	Test Conditions	Min.	Typ. ^[4]	Max.	Unit
I _{ODL}	Output LOW Current ^[6]	V _{CC} =5V, V _{IN} =V _{IH} or V _{IL} , V _{OUT} =1.5V	60	115	150	mA
I _{ODH}	Output HIGH Current ^[6]	V _{CC} =5V, V _{IN} =V _{IH} or V _{IL} , V _{OUT} =1.5V	-60	-115	-150	mA
V _{OH}	Output HIGH Voltage	V _{CC} =Min., I _{OH} =-24 mA	2.4	3.3		V
V _{OL}	Output LOW Voltage	V _{CC} =Min., I _{OL} =24 mA		0.3	0.55	V

Capacitance^[5] (T_A = +25°C, f = 1.0 MHz)

Parameter	Description	Test Conditions	Typ. ^[4]	Max.	Unit
C _{IN}	Input Capacitance	V _{IN} = 0V	4.5	6.0	pF
C _{OUT}	Output Capacitance	V _{OUT} = 0V	5.5	8.0	pF

Power Supply Characteristics

Parameter	Description	Test Conditions	Min.	Typ. ^[4]	Max.	Unit
I _{CC}	Quiescent Power Supply Current	V _{CC} =Max. V _{IN} ≤0.2V, V _{IN} ≥V _{CC} -0.2V	—	5	500	μA
ΔI _{CC}	Quiescent Power Supply Current (TTL inputs HIGH)	V _{CC} =Max. V _{IN} =3.4V ^[8]	—	0.5	1.5	mA
I _{CCD}	Dynamic Power Supply Current ^[9]	V _{CC} =Max., One Input Toggling, 50% Duty Cycle, Outputs Open, OE ₁ =OE ₂ =GND,	—	60	100	μA/MHz
I _C	Total Power Supply Current ^[10]	V _{CC} =Max., f ₁ =10 MHz, 50% Duty Cycle, Outputs Open, One Bit Toggling, OE ₁ =OE ₂ =GND	—	0.6	1.5	mA
		V _{IN} =V _{CC} or V _{IN} =GND	—	0.9	2.3	
		V _{IN} =V _{CC} or V _{IN} =GND	—	3.0	5.5 ^[11]	
		V _{IN} =3.4V or V _{IN} =GND	—	8.0	20.5 ^[11]	

Notes:

8. Per TTL driven input (V_{IN}=3.4V); all other inputs at V_{CC} or GND.
9. This parameter is not directly testable, but is derived for use in Total Power Supply calculations.
10. I_C = I_{QUIESCENT} + I_{INPUTS} + I_{DYNAMIC}
 I_C = I_{CC} + ΔI_{CC}D_HN_T + I_{CCD}(f₀/2 + f₁N₁)
 I_{CC} = Quiescent Current with CMOS input levels
 ΔI_{CC} = Power Supply Current for a TTL HIGH input (V_{IN}=3.4V)
 D_H = Duty Cycle for TTL inputs HIGH
 N_T = Number of TTL inputs at D_H
 I_{CCD} = Dynamic Current caused by an input transition pair (HLH or LHL)
 f₀ = Clock frequency for registered devices, otherwise zero
 f₁ = Input signal frequency
 N₁ = Number of inputs changing at f₁
 All currents are in milliamps and all frequencies are in megahertz.
11. Values for these conditions are examples of the I_{CC} formula. These limits are guaranteed but not tested.



Switching Characteristics Over the Operating Range^[12]

Parameter	Description	Condition ^[13]	CY74FCT16827AT CY74FCT162827AT		CY74FCT16827BT CY74FCT162827BT		Unit	Fig. No. ^[13]
			Min.	Max.	Min.	Max.		
t _{PLH} t _{PHL}	Propagation Delay A to Y	C _L =50 pF R _L =500Ω	1.5	8.0	1.5	5.0	ns	1, 3
		C _L =300 pF R _L =500Ω	1.5	15.0	1.5	13.0		
t _{PZH} t _{PZL}	Output Enable Time OE to Y	C _L =50 pF R _L =500Ω	1.5	12.0	1.5	8.0	ns	1, 7, 8
		C _L =300 pF R _L =500Ω	1.5	23.0	1.5	15.0		
t _{PHZ} t _{PLZ}	Output Disable Time OE to Y	C _L =5 pF R _L =500Ω	1.5	9.0	1.5	6.0	ns	1, 7, 8
		C _L =50 pF R _L =500Ω	1.5	10.0	1.5	7.0		
t _{SK(O)}	Output Skew ^[14]		—	0.5	—	0.5	ns	—

Parameter	Description	Condition ^[12]	CY74FCT16827CT CY74FCT162827CT		CY74FCT16827ET CY74FCT162827ET		Unit	Fig. No. ^[13]
			Min.	Max.	Min.	Max.		
t _{PLH} t _{PHL}	Propagation Delay A to Y	C _L =50 pF R _L =500Ω	1.5	4.2	1.5	3.2	ns	1, 3
		C _L =300 pF R _L =500Ω	1.5	10.0	1.5	7.0		
t _{PZH} t _{PZL}	Output Enable Time OE to Y	C _L =50 pF R _L =500Ω	1.5	5.6	1.5	4.8	ns	1, 7, 8
		C _L =300 pF R _L =500Ω	1.5	14.0	1.5	9.0		
t _{PHZ} t _{PLZ}	Output Disable Time OE to Y	C _L =5 pF R _L =500Ω	1.5	5.7	1.5	4.0	ns	1, 7, 8
		C _L =50 pF R _L =500Ω	1.5	6.0	1.5	4.0		
t _{SK(O)}	Output Skew ^[14]		—	0.5	—	0.5	ns	—

Notes:

- 12. Minimum limits are guaranteed but not tested on Propagation Delays.
- 13. See "Parameter Measurement Information" in the General Information section.
- 14. Skew between any two outputs of the same package switching in the same direction. This parameter is guaranteed by design.



Ordering Information CY74FCT16827

Speed (ns)	Ordering Code	Package Name	Package Type	Operating Range
3.2	CY74FCT16827ETPAC	Z56	56-Lead (240-Mil) TSSOP	Industrial
	CY74FCT16827ETPVC	O56	56-Lead (300-Mil) SSOP	
4.2	CY74FCT16827CTPAC	Z56	56-Lead (240-Mil) TSSOP	Industrial
	CY74FCT16827CTPVC	O56	56-Lead (300-Mil) SSOP	
5.0	CY74FCT16827BTPAC	Z56	56-Lead (240-Mil) TSSOP	Industrial
	CY74FCT16827BTPVC	O56	56-Lead (300-Mil) SSOP	
8.0	CY74FCT16827ATPAC	Z56	56-Lead (240-Mil) TSSOP	Industrial
	CY74FCT16827ATPVC	O56	56-Lead (300-Mil) SSOP	

Ordering Information CY74FCT162827

Speed (ns)	Ordering Code	Package Name	Package Type	Operating Range
3.2	CY74FCT162827ETPAC	Z56	56-Lead (240-Mil) TSSOP	Industrial
	CY74FCT162827ETPVC	O56	56-Lead (300-Mil) SSOP	
4.2	CY74FCT162827CTPAC	Z56	56-Lead (240-Mil) TSSOP	Industrial
	CY74FCT162827CTPVC	O56	56-Lead (300-Mil) SSOP	
5.0	CY74FCT162827BTPAC	Z56	56-Lead (240-Mil) TSSOP	Industrial
	CY74FCT162827BTPVC	O56	56-Lead (300-Mil) SSOP	
8.0	CY74FCT162827ATPAC	Z56	56-Lead (240-Mil) TSSOP	Industrial
	CY74FCT162827ATPVC	O56	56-Lead (300-Mil) SSOP	

Document #: 38-00393-C

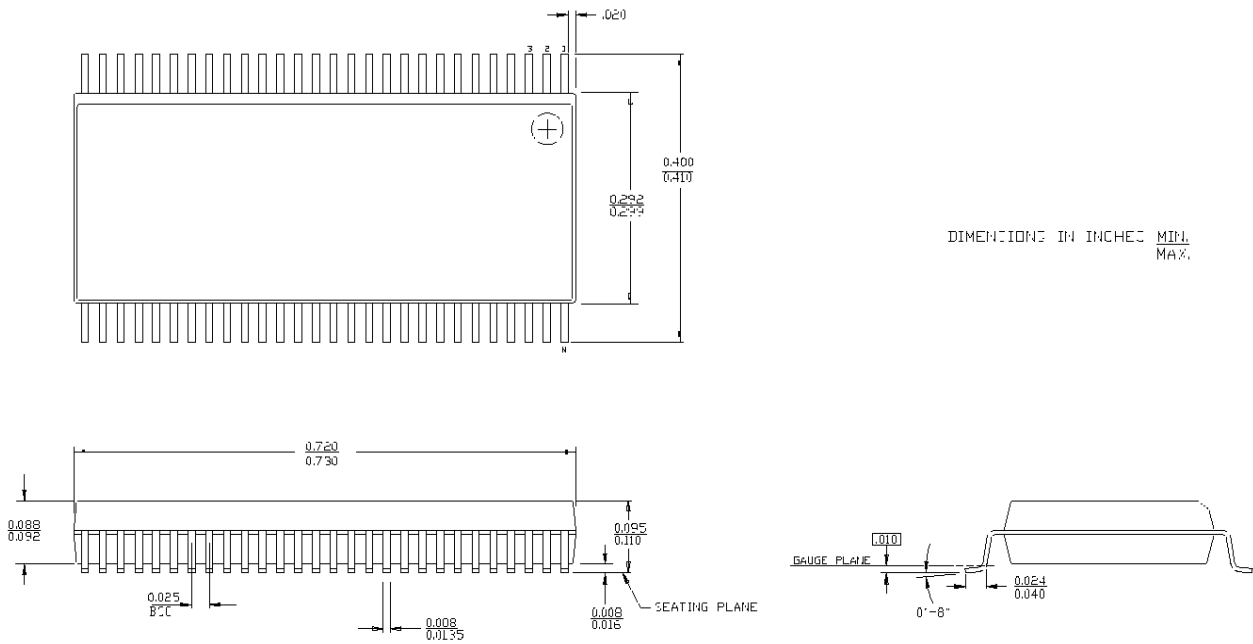
Package Diagrams
56-Lead Shrunken Small Outline Package O56

56-Lead Thin Shrunken Small Outline Package Z56
