

# USB/AC Adapter, Li+ Linear Battery Charger with Integrated 50mΩ Battery Switch in TDFN

## General Description

The MAX8856 complete 1-cell Li+ battery charge-management IC operates from either a USB port or AC adapter. It integrates a battery disconnect switch, current-sense circuit, PMOS pass element, and thermal-regulation circuitry, while eliminating the external reverse-blocking Schottky diode, to create a simple and small charging solution. The charging sequence initiates from power-OK indication, through prequalification, fast-charge, top-off charge, and finally charging-complete indication for single-cell Li+ batteries. Charging is controlled using constant current, constant voltage, or constant die-temperature (CCCCT<sub>J</sub>) regulation for safe operation in handhelds.

Two logic inputs ( $\overline{EN1}$ ,  $\overline{EN2}$ ) select suspend mode, 100mA, 500mA, or  $\leq 1A$  input current limits to comply with USB requirements. Proprietary thermal-regulation circuitry limits the die temperature to +100°C to prevent excessive heat on the system PC board. Additional safety features include an NTC thermistor input (THM) to protect the battery. A 3.5V to 4.2V SYS output, in conjunction with the low-R<sub>DS(on)</sub> battery switch, powers the system even when the battery is deeply discharged or not installed. The IC also offers a +3.3V/500μA output (V<sub>L</sub>), a charging status flag (CHG), and an input-supply detection flag (POK). The MAX8856 operates from a +4.25V to +5.5V supply and includes undervoltage lockout below +3.4V and overvoltage protection up to +14V.

## Applications

Cellular Phones, Smartphones, PDAs  
Digital Cameras, MP3 Players  
USB Appliances, Charging Cradles and Docks

## Pin Configuration

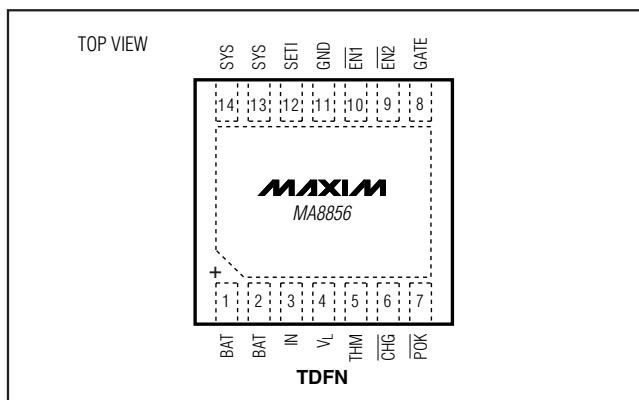

## Features

- ◆ Small, 3mm x 3mm Thermally Enhanced TDFN Package (0.8mm max height)
- ◆ USB-Compliant Suspend Mode (20μA)
- ◆ Selectable 100mA, 500mA, and Up to 1A Input Current Limits
- ◆ USB or AC Adapter Input
- ◆ +6V to +14V Input Overvoltage Protection
- ◆ Input UVLO Below +4V Rising (3.5V Falling)
- ◆ Automatic Current Sharing Between Battery Charging and System
- ◆ Die Temperature Regulation (+100°C)
- ◆ Low Dropout Voltage, 250mV at 0.5A
- ◆ NTC Thermistor Input
- ◆ Charge Status and Input-Supply Detection Flags

## Ordering Information

PART	TEMP RANGE	PIN-PACKAGE	TOP MARK
MAX8856ETD+	-40°C to +85°C	14 TDFN 3mm x 3mm (T1433-1)	AEJ

+Denotes a lead-free/RoHS-compliant package.

## Typical Operating Circuit

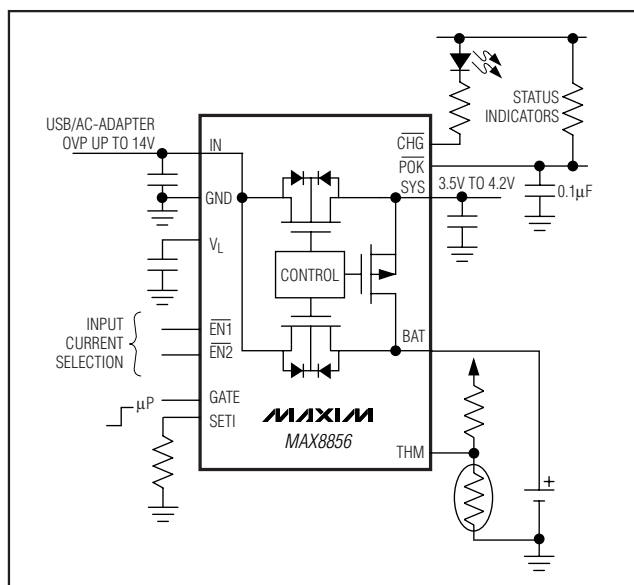

# USB/AC Adapter, Li+ Linear Battery Charger with Integrated 50mΩ Battery Switch in TDFN

## ABSOLUTE MAXIMUM RATINGS

IN to GND .....	-0.3V to +16V
BAT, SYS, $\overline{EN1}$ , $\overline{EN2}$ , POK, CHG, GATE to GND .....	-0.3V to +6V
$V_L$ , SET1, THM to GND .....	-0.3V to +4V
SYS to BAT .....	-0.3V to +6V
$V_L$ to IN .....	-16V to +0.3V
IN to BAT Current .....	1.0A <sub>RMS</sub>
IN to SYS Current .....	1.0A <sub>RMS</sub>
BAT to SYS Current .....	1.0A <sub>RMS</sub>
BAT Short-Circuit Duration .....	Continuous

Continuous Power Dissipation ( $T_A = +70^\circ\text{C}$ )	
14-Pin 3mm x 3mm TDFN (derate 18.2mW/ $^\circ\text{C}$ above $+70^\circ\text{C}$ ) .....	1454mW
Operating Temperature Range .....	-40 $^\circ\text{C}$ to +85 $^\circ\text{C}$
Junction Temperature Range .....	-40 $^\circ\text{C}$ to +150 $^\circ\text{C}$
Storage Temperature Range .....	-65 $^\circ\text{C}$ to +150 $^\circ\text{C}$
Lead Temperature (soldering, 10s) .....	+300 $^\circ\text{C}$

Stresses beyond those listed under "Absolute Maximum Ratings" may cause permanent damage to the device. These are stress ratings only, and functional operation of the device at these or any other conditions beyond those indicated in the operational sections of the specifications is not implied. Exposure to absolute maximum rating conditions for extended periods may affect device reliability.

## ELECTRICAL CHARACTERISTICS

( $V_{IN} = 5.0\text{V}$ ,  $V_{BAT} = 3.3\text{V}$ ,  $\overline{EN1} = \overline{EN2} = \text{GND}$ ,  $R_{SET1} = 23.58\text{k}\Omega$ ,  $C_{VL} = 0.1\mu\text{F}$ ,  $C_{SYS} = 4.7\mu\text{F}$ ,  $T_A = -40^\circ\text{C}$  to  $+85^\circ\text{C}$ , unless otherwise noted. Typical values are at  $T_A = +25^\circ\text{C}$ .) (Note 1)

PARAMETER	CONDITIONS	MIN	TYP	MAX	UNITS	
<b>IN</b>						
IN Voltage Range		0		14	V	
IN Operating Voltage Range	(Note 2)	4.25		5.50	V	
IN Undervoltage Threshold	$V_{IN}$ rising, 500mV hysteresis (typ)	3.9	4.0	4.1	V	
IN Overvoltage Threshold	$V_{IN}$ rising, 150mV hysteresis (typ)	5.6	5.8	6.0	V	
IN Supply Current	Charging, $I_{BAT} = I_{SYS} = 0\text{mA}$		1.2	3.0	mA	
	Suspend, $\overline{EN1} = \overline{EN2} = \text{high}$ , $I_{VL} = 0\text{mA}$		20	40	$\mu\text{A}$	
IN to BAT Switch Leakage	$V_{IN} = 14\text{V}$ , $\text{BAT} = \text{GND}$	$T_A = +25^\circ\text{C}$	0.1	10	$\mu\text{A}$	
		$T_A = +85^\circ\text{C}$	0.5			
<b>SYS</b>						
SYS Regulated Voltage	$I_{SYS} = 0\text{mA}$ , $V_{BAT} = 3.3\text{V}$	3.4	3.5	3.6	V	
SYS Current Limit	$V_{SYS} = 3.3\text{V}$	$\overline{EN1} = \text{low}$ , $\overline{EN2} = \text{low}$	90	96	100	mA
		$\overline{EN1} = \text{low}$ , $\overline{EN2} = \text{high}$	450	475	500	
		$\overline{EN1} = \text{high}$ , $\overline{EN2} = \text{low}$	675	712	750	
SYS Dropout Voltage ( $V_{IN} - V_{BAT}$ )	$I_{SYS} = 400\text{mA}$ , $V_{SYS} = 3.3\text{V}$ , $\overline{EN1} = \text{low}$ , $\overline{EN2} = \text{high}$		350	700	mV	
SYS Load Regulation	$I_{SYS} = 1\text{mA}$ to $675\text{mA}$ , $\overline{EN1} = \text{high}$ , $\overline{EN2} = \text{low}$		10		mV	
<b>BAT</b>						
BAT Regulation Voltage	$I_{BAT} = 0\text{mA}$	$T_A = +25^\circ\text{C}$	4.18	4.20	4.22	V
		$T_A = -40^\circ\text{C}$ to $+85^\circ\text{C}$	4.16	4.20	4.24	
Maximum Charging Current		1			A	
BAT Charging Current	$\overline{EN1} = \text{low}$ , $\overline{EN2} = \text{low}$	$I_{SYS} = 0\text{mA}$	87	95	100	mA
		$I_{SYS} = 50\text{mA}$		45		
	$\overline{EN1} = \text{low}$ , $\overline{EN2} = \text{high}$	$I_{SYS} = 0\text{mA}$	450	475	500	
		$I_{SYS} = 250\text{mA}$		225		
	$\overline{EN1} = \text{high}$ , $\overline{EN2} = \text{low}$	$I_{SYS} = 0\text{mA}$	675	712	750	
$I_{SYS} = 375\text{mA}$			337			

# USB/AC Adapter, Li+ Linear Battery Charger with Integrated 50mΩ Battery Switch in TDFN

MAX8856

## ELECTRICAL CHARACTERISTICS (continued)

( $V_{IN} = 5.0V$ ,  $V_{BAT} = 3.3V$ ,  $\overline{EN1} = \overline{EN2} = GND$ ,  $R_{SET1} = 23.58k\Omega$ ,  $C_{VL} = 0.1\mu F$ ,  $C_{SYS} = 4.7\mu F$ ,  $T_A = -40^\circ C$  to  $+85^\circ C$ , unless otherwise noted. Typical values are at  $T_A = +25^\circ C$ .) (Note 1)

PARAMETER	CONDITIONS		MIN	TYP	MAX	UNITS	
BAT Prequal Current	$V_{BAT} = 2.0V$	$\overline{EN1} = \text{low}, \overline{EN2} = \text{low}, I_{SYS} = 0mA$	87	95	100	mA	
		$\overline{EN1} = \text{low}, \overline{EN2} = \text{high}, I_{SYS} = 0$ to 350mA		95			
		$\overline{EN1} = \text{high}, \overline{EN2} = \text{low}, I_{SYS} = 0$ to 575mA		95			
Soft-Start Time			1.5			ms	
BAT Prequal Threshold	$V_{BAT}$ rising, 150mV hysteresis (typ)		2.9	3.0	3.1	V	
BAT Dropout Voltage ( $V_{IN} - V_{BAT}$ )	$V_{BAT} = 4.1V, I_{BAT} = 400mA$			200	400	mV	
BAT Short-Circuit Current Limit	BAT = GND		70	95	120	mA	
BAT to SYS Switch $R_{ON}$	$V_{BAT} = 3.5V, V_{SYS} = 3.4V, V_{IN} = 0V$			50	100	mΩ	
BAT to SYS Switch Threshold	BAT rising, 160mV hysteresis (typ)		3.4	3.5	3.6	V	
Battery-Removal Threshold	BAT rising, 210mV hysteresis (typ)		4.5	4.75	5.0	V	
BAT Leakage Current	$V_{IN} = 0V$	$T_A = +25^\circ C$		0.1	10	μA	
		$T_A = +85^\circ C$		0.1			
	$V_{IN} = 2.4V$	$T_A = +25^\circ C$		0.1	10		
		$T_A = +85^\circ C$		0.1			
	$\overline{EN1} = \text{high}, \overline{EN2} = \text{high}$	$T_A = +25^\circ C$	-10	0.1	+10		
		$T_A = +85^\circ C$		0.1			
<b>V<sub>L</sub></b>							
V <sub>L</sub> Output Voltage	$I_{VL} = 0$ to 500μA		3.1	3.3	3.5	V	
V <sub>L</sub> Shutdown Voltage	$V_{\overline{EN1}} = V_{\overline{EN2}} = 5V$			0		V	
<b>THM</b>							
THM Threshold, Hot	10% hysteresis, $V_{THM}$ falling	Expressed as percentage of $V_L$	21.5	22.5	23.5	%	
THM Threshold, Cold	10% hysteresis, $V_{THM}$ rising		53.0	54.0	55.5		
THM Threshold, Disabled	70% hysteresis, $V_{THM}$ falling		2.5	3.0	3.5		
<b>SET1</b>							
SET1 Servo Voltage	$\overline{EN1} = \text{low}, \overline{EN2} = \text{low}$			0.28		V	
	$\overline{EN1} = \text{low}, \overline{EN2} = \text{high}$			1.4			
	$\overline{EN1} = \text{high}, \overline{EN2} = \text{low}$			2.1			
SET1 Resistance Range			17.68	23.58	35.36	kΩ	
<b>POK</b>							
POK Trip Threshold ( $V_{IN} - V_{BAT}$ )	4.1V < $V_{IN}$ < 5.6V, $V_{BAT} = 4.1V$		$V_{IN}$ rising	150	250	350	mV
			$V_{IN}$ falling	5	55	125	
POK Voltage, Low	$I_{\overline{POK}} = 5mA$			0.05	0.2	V	
$\overline{POK}$ Leakage Current, High	$V_{\overline{POK}} = 6V$		$T_A = +25^\circ C$		0.01	1	μA
			$T_A = +85^\circ C$		0.01		

# USB/AC Adapter, Li+ Linear Battery Charger with Integrated 50mΩ Battery Switch in TDFN

## ELECTRICAL CHARACTERISTICS (continued)

( $V_{IN} = 5.0V$ ,  $V_{BAT} = 3.3V$ ,  $\overline{EN1} = \overline{EN2} = GND$ ,  $R_{SET1} = 23.58k\Omega$ ,  $C_{VL} = 0.1\mu F$ ,  $C_{SYS} = 4.7\mu F$ ,  $T_A = -40^\circ C$  to  $+85^\circ C$ , unless otherwise noted. Typical values are at  $T_A = +25^\circ C$ .) (Note 1)

PARAMETER	CONDITIONS	MIN	TYP	MAX	UNITS
<b>CHG</b>					
Full-Battery Detection Current Threshold	$I_{BAT}$ falling	30	50	70	mA
$\overline{CHG}$ Voltage, Low	$I_{\overline{CHG}} = 5mA$		0.05	0.2	V
$\overline{CHG}$ Leakage Current, High	$V_{\overline{CHG}} = 6V$		0.01	1	$\mu A$
			0.01		
<b>EN1, EN2, GATE</b>					
Logic Input Leakage Current	$V_{GATE} = V_{\overline{EN1}} = V_{\overline{EN2}} = 0$ to $5.5V$		0.01	1	$\mu A$
			0.01		
Logic Input Low Voltage				0.4	V
Logic Input High Voltage		1.6			V
<b>THERMAL LIMIT</b>					
Thermal-Regulation Threshold			+100		$^\circ C$
Thermal-Regulation Gain	$T_J$ to $I_{BAT}$ , $T_J > +100^\circ C$		-50		$mA/^\circ C$

**Note 1:** Specifications are 100% production tested at  $T_A = +25^\circ C$ . Limits over the operating temperature range are guaranteed by design and characterization.

**Note 2:** Guaranteed by undervoltage and overvoltage threshold testing.

# USB/AC Adapter, Li+ Linear Battery Charger with Integrated 50mΩ Battery Switch in TDFN

MAX8856

## Typical Operating Characteristics

( $V_{IN} = +5V$ ,  $V_{BAT} = 3.6V$ ,  $I_{SYS} = 0$ ,  $\overline{EN1} = 1$ ,  $\overline{EN2} = 0$ , circuit of Figure 3,  $T_A = +25^\circ C$ , unless otherwise noted.)

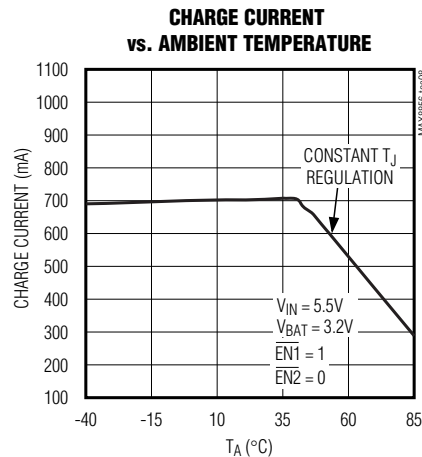
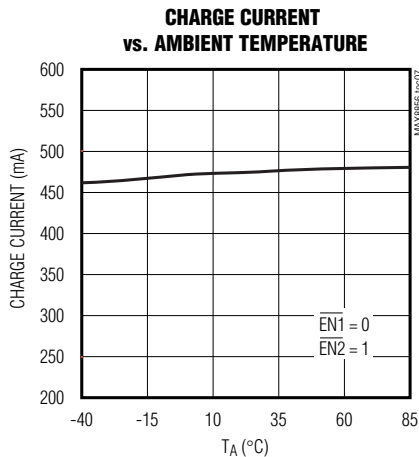
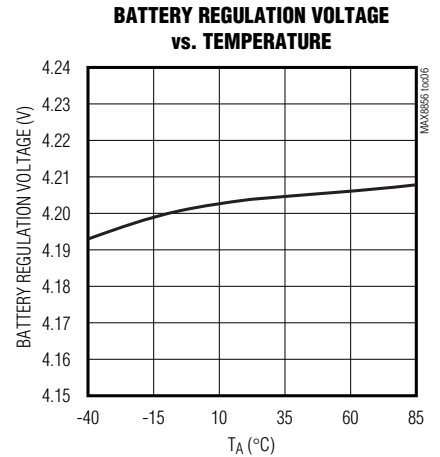
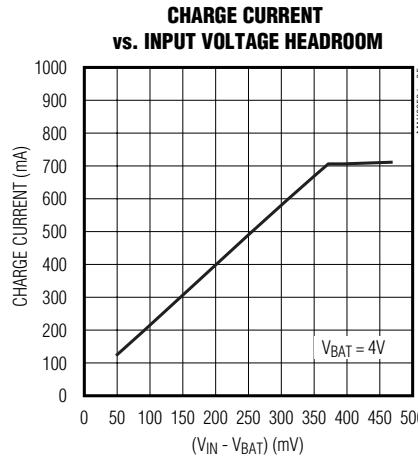
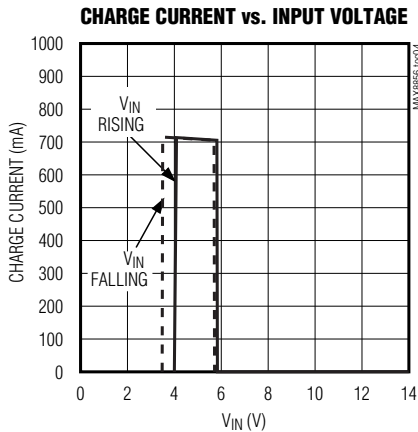
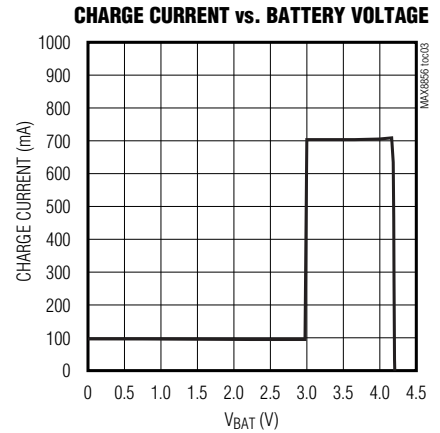
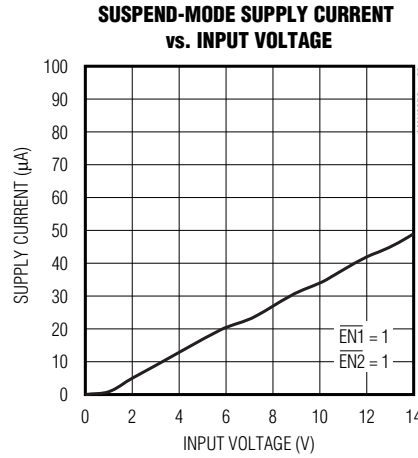
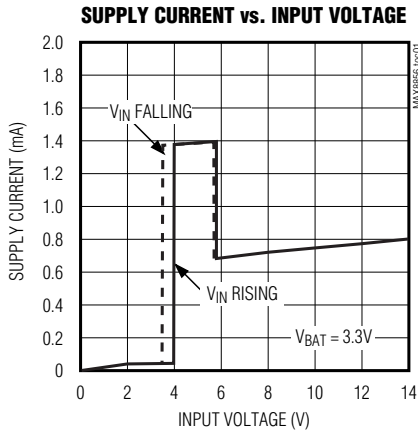

# USB/AC Adapter, Li+ Linear Battery Charger with Integrated 50mΩ Battery Switch in TDFN

## Pin Description

PIN	NAME	FUNCTION
1, 2	BAT	Battery Connection. The IC delivers charging current and monitors battery voltage using BAT. Connect both BAT outputs together externally. During suspend mode, BAT is internally connected to SYS.
3	IN	Supply Voltage Input. Connect IN to a 4.25V to 5.5V supply. Charging is suspended if $V_{IN}$ exceeds 6V. Bypass IN to GND with a 4.7μF or larger ceramic capacitor.
4	$V_L$	+3.3V Output Voltage and Logic Supply. $V_L$ is regulated to +3.3V and is capable of sourcing 500μA to provide power for external circuits. Bypass $V_L$ to GND with a 0.1μF or larger ceramic capacitor. $V_L$ is internally pulled to GND during suspend mode.
5	THM	Thermistor Input. Connect a 47kΩ NTC thermistor from THM to GND in close proximity to the battery to monitor the battery temperature. The IC suspends charging when the temperature is outside the hot and cold limits. Connect THM to GND to disable the thermistor monitoring function. See the <i>THM Input</i> section for more details.
6	$\overline{\text{CHG}}$	Charging Status Output. $\overline{\text{CHG}}$ is an open-drain output that goes low when the battery is charging. $\overline{\text{CHG}}$ goes high impedance when the charge current drops below 50mA (typ) and the battery voltage is 4.2V (typ). $\overline{\text{CHG}}$ is high impedance when the IC is in suspend mode.
7	$\overline{\text{POK}}$	Power-OK Monitor. $\overline{\text{POK}}$ is an open-drain output that pulls low when a valid charging source is detected at IN.
8	GATE	MOSFET Enable/Disable Input. Drive GATE high to turn off the MOSFET between SYS and BAT, resulting in opening of the connection between SYS and BAT. Drive GATE low to enable automatic control of the MOSFET switch, as described in the <i>Gate Input and SYS Output</i> section.
9	$\overline{\text{EN2}}$	Charge-Current Selection Input. Drive $\overline{\text{EN2}}$ high or low to select the charge current or to put the MAX8856 into suspend mode (see Table 1).
10	$\overline{\text{EN1}}$	Charge-Current Selection Input. Drive $\overline{\text{EN1}}$ high or low to select the charge current or to put the MAX8856 into suspend mode (see Table 1).
11	GND	Ground. Connect directly to exposed paddle under the IC.
12	SET1	Charge-Current Programming Input. Connect a resistor from SET1 to GND to set the maximum charging current. $R_{SET1}$ must be between 17.68kΩ and 35.36kΩ.
13, 14	SYS	System Supply Output. SYS delivers up to 1A <sub>RMS</sub> to power an external system. Bypass SYS to GND with a 4.7μF or larger ceramic capacitor. SYS is connected to BAT through an internal 50mΩ switch when $V_{BAT}$ exceeds 3.5V or when the MAX8856 is in suspend mode.
—	EP	Exposed Paddle. Connect to GND under the IC. Connect to a large ground plane to improve power dissipation.

## Detailed Description

The MAX8856 charger uses current, voltage, and thermal control loops to charge and protect a single Li+ battery cell. It can start the system even when the battery is in deep saturation. The MAX8856 provides a SYS output that supplies the external system with a minimum 3.5V at 1A.

Two active-low enable inputs ( $\overline{\text{EN1}}$  and  $\overline{\text{EN2}}$ ) are supplied to set the SYS and charging current limits. During prequal and fast-charge modes, the  $\overline{\text{CHG}}$  output status flag is pulled low. As the battery voltage approaches

4.2V, the charging current is reduced. When the charging current drops below 50mA and the battery voltage equals 4.2V, the  $\overline{\text{CHG}}$  output goes high impedance, signaling a full battery. At any time during charging, if both  $\overline{\text{EN1}}$  and  $\overline{\text{EN2}}$  are driven high, the MAX8856 enters suspend mode, charging stops, and  $\overline{\text{CHG}}$  goes high impedance.

### $\overline{\text{EN1}}$ and $\overline{\text{EN2}}$ Inputs

$\overline{\text{EN1}}$  and  $\overline{\text{EN2}}$  are logic inputs that enable the charger and select the charging current (see Table 1). Drive  $\overline{\text{EN1}}$  and  $\overline{\text{EN2}}$  high to place the IC in suspend mode.

# USB/AC Adapter, Li+ Linear Battery Charger with Integrated 50mΩ Battery Switch in TDFN

MAX8856

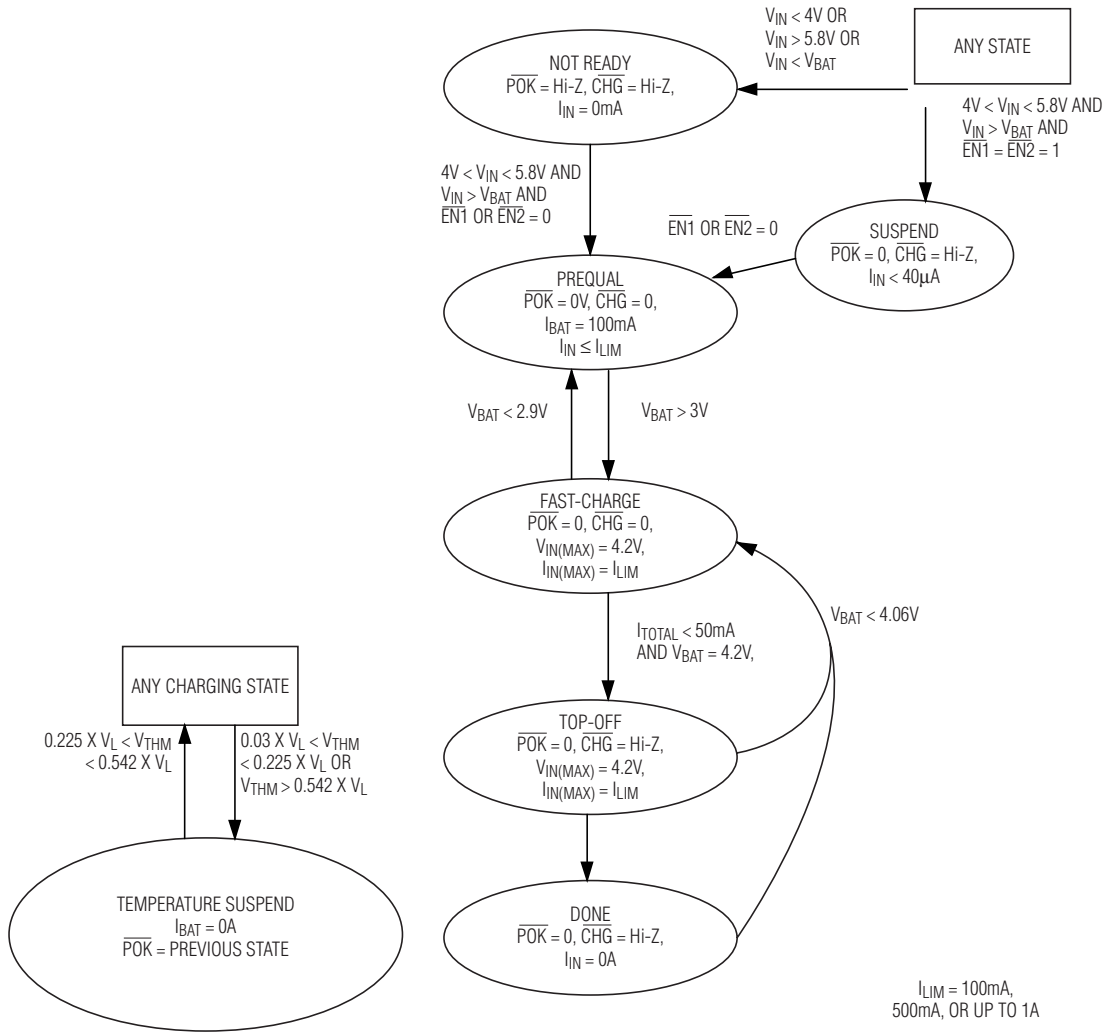

Figure 1. MAX8856 State Diagram

# USB/AC Adapter, Li+ Linear Battery Charger with Integrated 50mΩ Battery Switch in TDFN

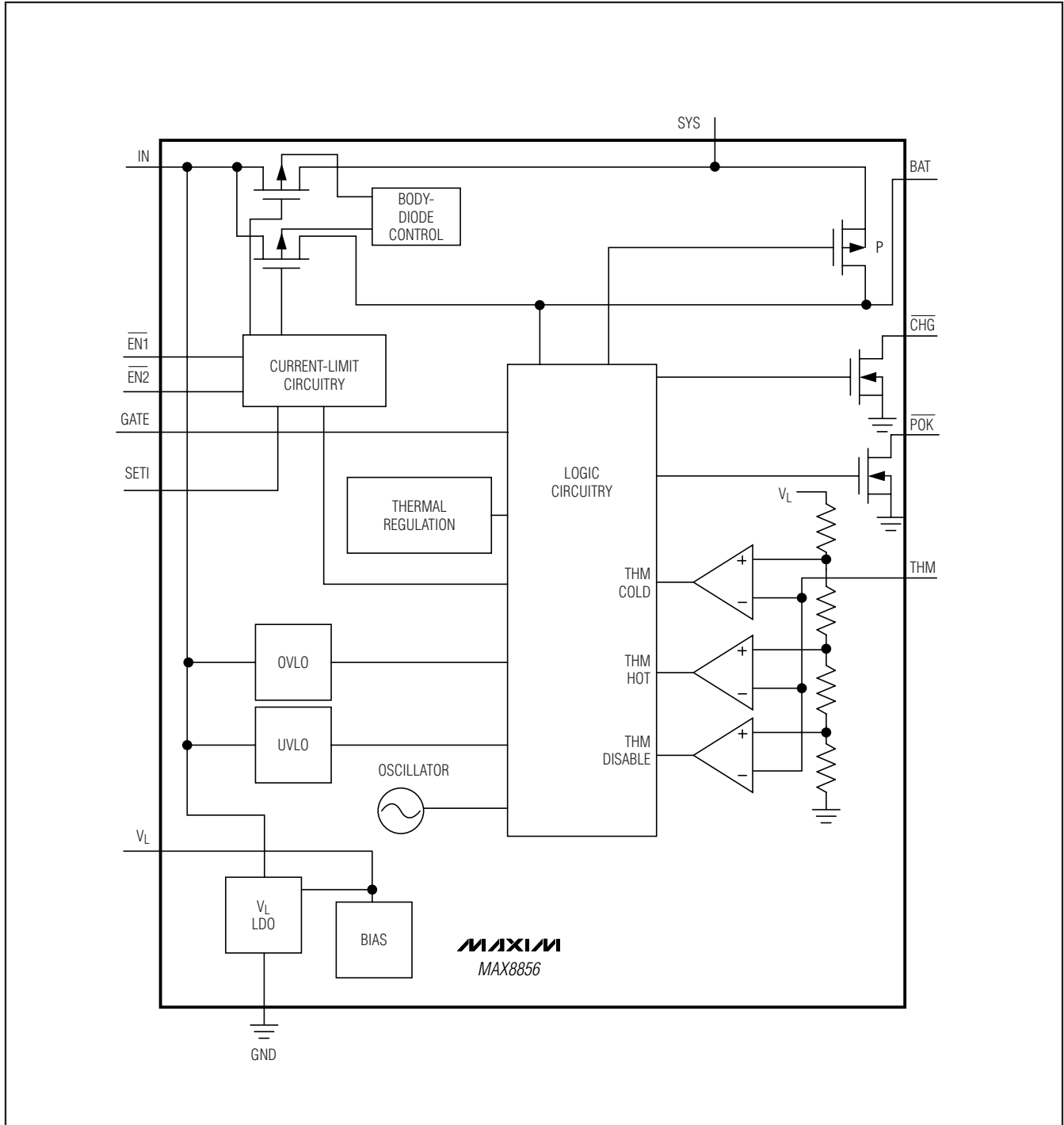

Figure 2. MAX8856 Block Diagram



# USB/AC Adapter, Li+ Linear Battery Charger with Integrated 50mΩ Battery Switch in TDFN

**Table 1. Logic Controls**

$\overline{\text{EN1}}$	$\overline{\text{EN2}}$	MODE
0	0	100mA
0	1	500mA
1	0	8000 x 2.1V / R <sub>SET</sub>
1	1	Suspend

### **V<sub>L</sub> Internal Voltage Regulator**

The MAX8856 linear charger contains an internal linear regulator to supply the power for the IC. Bypass V<sub>L</sub> to GND with a 0.1μF ceramic capacitor. V<sub>L</sub> is regulated to 3.3V whenever the input voltage is above the battery voltage and can source up to 500μA for external loads.

### **CHG Charge Indicator Output**

CHG is an open-drain output that indicates charger status and can be used with an LED. CHG goes low during charging. CHG goes high impedance when V<sub>BAT</sub> equals 4.2V and the charging current drops below 50mA, or when the MAX8856 is in suspend mode. When the MAX8856 is used in conjunction with a microprocessor (μP), connect a pullup resistor between CHG and the logic I/O voltage to indicate charge status to the μP.

### **Soft-Start**

To prevent input transients, the rate of change of the charge current is limited when the charger is turned on or changes its current compliance. It takes approximately 1ms for the charger to go from 0mA to the maximum fast-charge current.

### **THM Input**

The MAX8856 monitors the battery temperature with an external NTC thermistor that is in close thermal contact with the battery. Select a thermistor resistance that is 47kΩ at +25°C and has a beta of 3400 Kelvins. The IC compares the voltage at THM to an internal reference voltage generated from V<sub>L</sub> and suspends charging when it is greater than 0.542 x V<sub>L</sub> or less than 0.225 x V<sub>L</sub>. Connect THM to GND to disable the temperature control function.

### **GATE Input and SYS Output**

The MAX8856 contains a SYS output that delivers up to 1A<sub>RMS</sub> at 3.5V to 4.2V to power an external system. Bypass SYS to GND with a 4.7μF or larger ceramic capacitor. When V<sub>BAT</sub> exceeds 3.5V or when the MAX8856 is in suspend mode, and the GATE signal is low, the MAX8856 internally connects SYS to BAT

**Table 2. Charger Operation Truth Table**

GATE	SUSPEND MODE	CHARGER PRESENT	V <sub>BAT</sub> > 3.5V	MOSFET SWITCH
Low	No	No	No	Closed
Low	No	No	Yes	Closed
Low	No	Yes	No	Open
Low	No	Yes	Yes	Closed
Low	Yes	Yes	No	Closed
Low	Yes	Yes	Yes	Closed
High	X	X	X	Open

through a 50mΩ switch. When the GATE signal is driven HIGH, the SYS to BAT switch is held open, regardless of operating condition. See Tables 1 and 2 for more information.

When charging a battery, the load on SYS is serviced first and the remaining available current goes to charge the battery. SYS is connected to BAT when V<sub>IN</sub> is not valid.

### **POK**

The MAX8856 contains an open-drain POK output that goes low when a valid input source is detected at IN. A valid input source is one whose voltage is between 4V and 5.8V and exceeds the battery voltage by 250mV. After a valid input has been established, charging is sustained with inputs as low as 3.5V as long as the input voltage remains above the battery voltage by at least 55mV. POK is high impedance otherwise.

## **Applications Information**

### **Charge-Current Selection**

For USB applications, the charging current is internally limited to 100mA or 500mA. For wall-cube applications requiring a different current requirement, set the charging current with an external resistor from SET1 to GND (R<sub>SET1</sub>). Calculate R<sub>SET1</sub> as follows:

$$R_{SET1} = 8000 \times 2.1V / (I_{BAT} + I_{SYS})$$

where  $\overline{\text{EN1}}$  = high and  $\overline{\text{EN2}}$  = low.

The SET1 input also enables the user to monitor the charging current. Under fast-charge operation, the SET1 voltage regulates to 1.4V ( $\overline{\text{EN1}}$  low and  $\overline{\text{EN2}}$  high) or 2.1V ( $\overline{\text{EN1}}$  high and  $\overline{\text{EN2}}$  low). As the charging current decreases, V<sub>SET1</sub> decreases. This is due to either the thermal regulation control or voltage regulation control (4.2V) of the MAX8856. V<sub>SET1</sub> is calculated using the following equation:

$$V_{SET1} = (I_{BAT} + I_{SYS}) \times R_{SET1} / 8000$$

# USB/AC Adapter, Li+ Linear Battery Charger with Integrated 50mΩ Battery Switch in TDFN

## Thermal Regulation

The MAX8856 features a thermal limit that reduces the charge current when the die temperature exceeds +100°C. As the temperature increases, the IC lowers the charge current by 50mA/°C above +100°C.

## Capacitor Selection

Connect a ceramic capacitor from SYS to GND as close to the IC as possible for proper stability. Use a 4.7μF X5R ceramic capacitor for most applications.

Connect a 4.7μF ceramic capacitor from IN to GND as close to the IC as possible. Use a larger input bypass capacitor to reduce supply noise.

## Thermal Considerations

The MAX8856 is available in a thermally enhanced TDFN package with exposed paddle. Connect the exposed paddle to a large copper ground plane to provide a good thermal contact between the device and the circuit board. The exposed paddle transfers heat away from the device, allowing the MAX8856 to charge the battery with maximum current while minimizing the increase in die temperature.

## DC Input Sources

The MAX8856 operates from well-regulated DC sources. The full-charging input voltage range is 4.25V to 5.8V. The device survives input voltages up to 14V without damage to the IC. If  $V_{IN}$  is greater than 5.8V (typ), the IC stops charging. An appropriate power supply must provide at least 4.25V when sourcing the desired peak charging current. It also must stay below 5.8V when unloaded.

## Application Circuits

### Stand-Alone Li+ Charger

The MAX8856 provides a complete Li+ charging solution. Figure 3 shows the MAX8856 as a stand-alone Li+ battery charger. The 23.58kΩ resistor connected to SETI sets a charging current of 712mA (typ). The LED indicates when either prequal or fast-charging has begun. When the battery is charged the LED turns off.

### USB Application with AC Adapter

The MAX8856 can be configured for USB applications with an optional AC-adaptor input (Figure 4). The p-channel MOSFET disconnects the USB port when the AC adapter is installed. Alternately, the USB port and AC adapter may be excluded from each other by mechanical means, such as using a single connector.

### USB-Powered Li+ Charger

The universal serial bus (USB) provides a high-speed serial communication port, as well as power for the

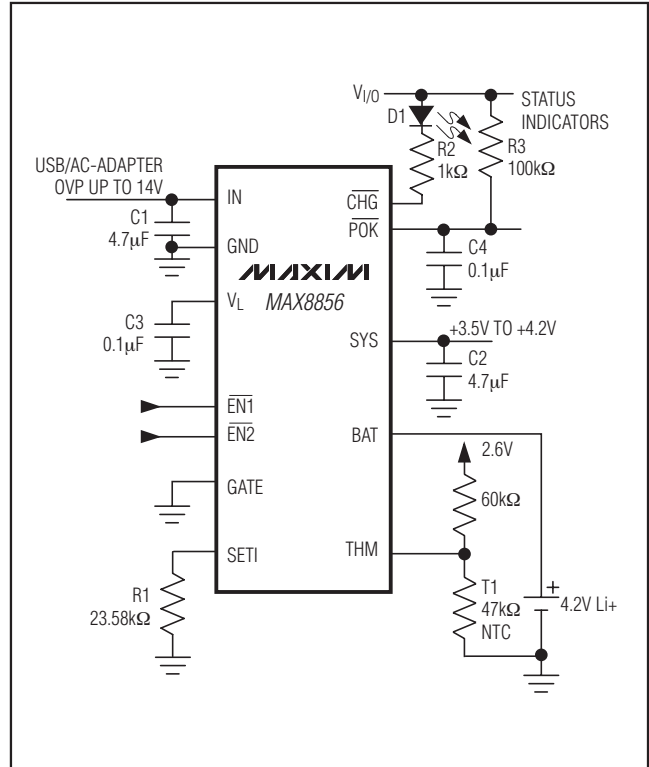

Figure 3. Stand-Alone Application

remote device. The MAX8856 can be configured to charge a battery at the highest current possible from the host port. Figure 5 shows the MAX8856 as a USB battery charger. To make the circuit compatible with either 100mA or 500mA USB ports, the system software begins at 100mA charging current. The microprocessor then enumerates with the host to determine its current capability. If the host port is capable, the charging current is increased to 475mA to avoid exceeding the 500mA USB specification.

## Layout and Bypassing

Place the input capacitor as close to the device as possible. Provide a large copper ground plane to allow the exposed paddle to sink heat away from the device. Connect the battery to BAT as close to the device as possible to provide accurate battery voltage sensing. Make all high-current traces short and wide to minimize voltage drops. A sample layout is available in the MAX8856 evaluation kit to help speed designs.

## Chip Information

PROCESS: BiCMOS

# USB/AC Adapter, Li+ Linear Battery Charger with Integrated 50mΩ Battery Switch in TDFN

MAX8856

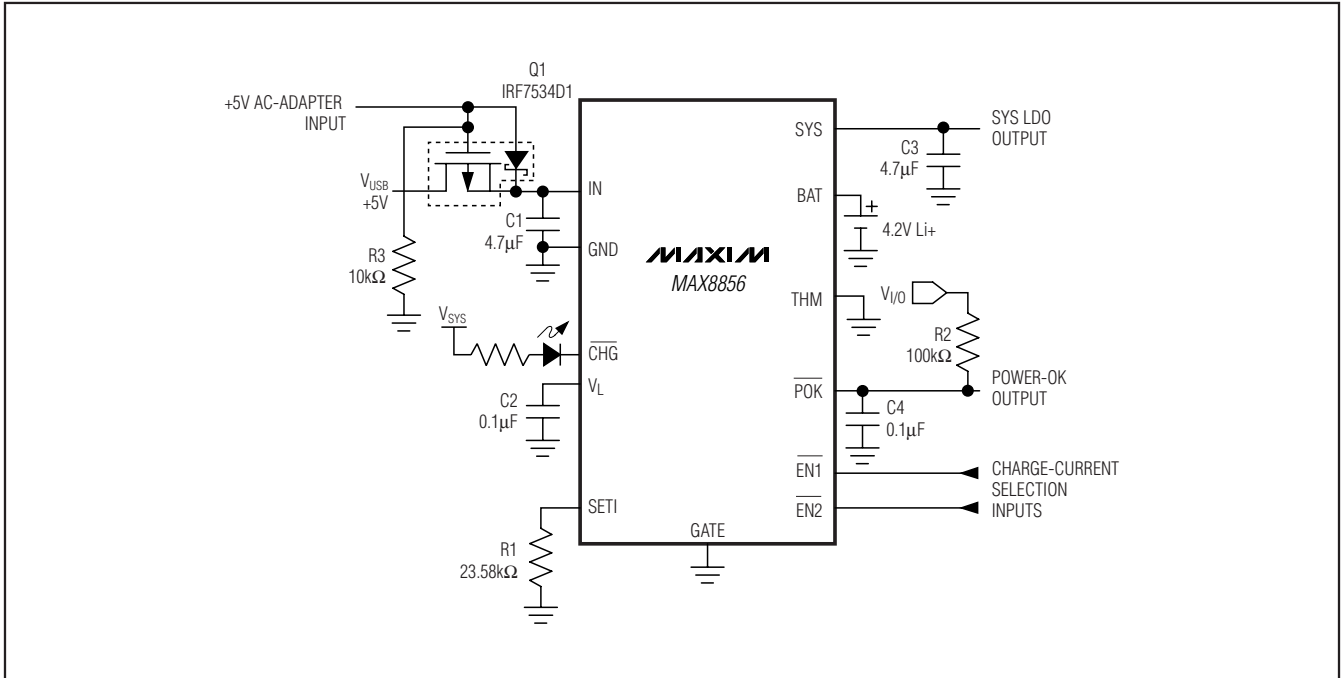

Figure 4. USB Application with AC Adapter

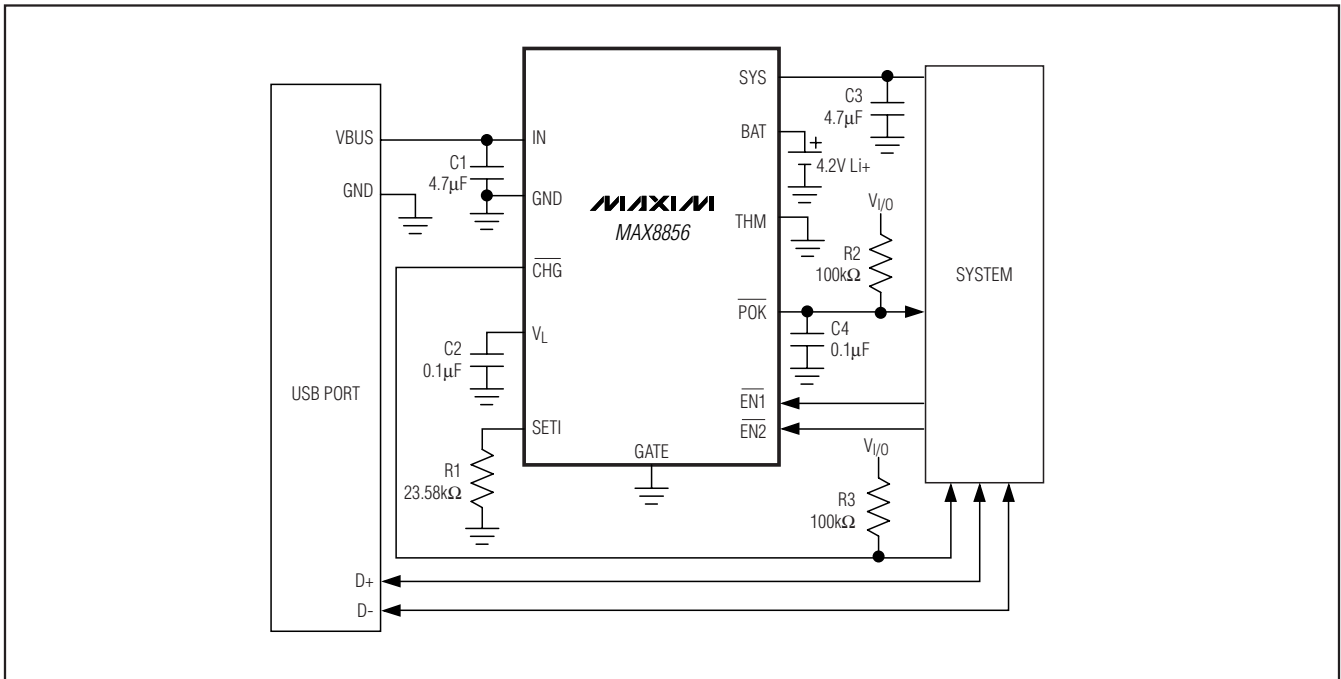

Figure 5. USB Charger Application

# USB/AC Adapter, Li+ Linear Battery Charger with Integrated 50mΩ Battery Switch in TDFN

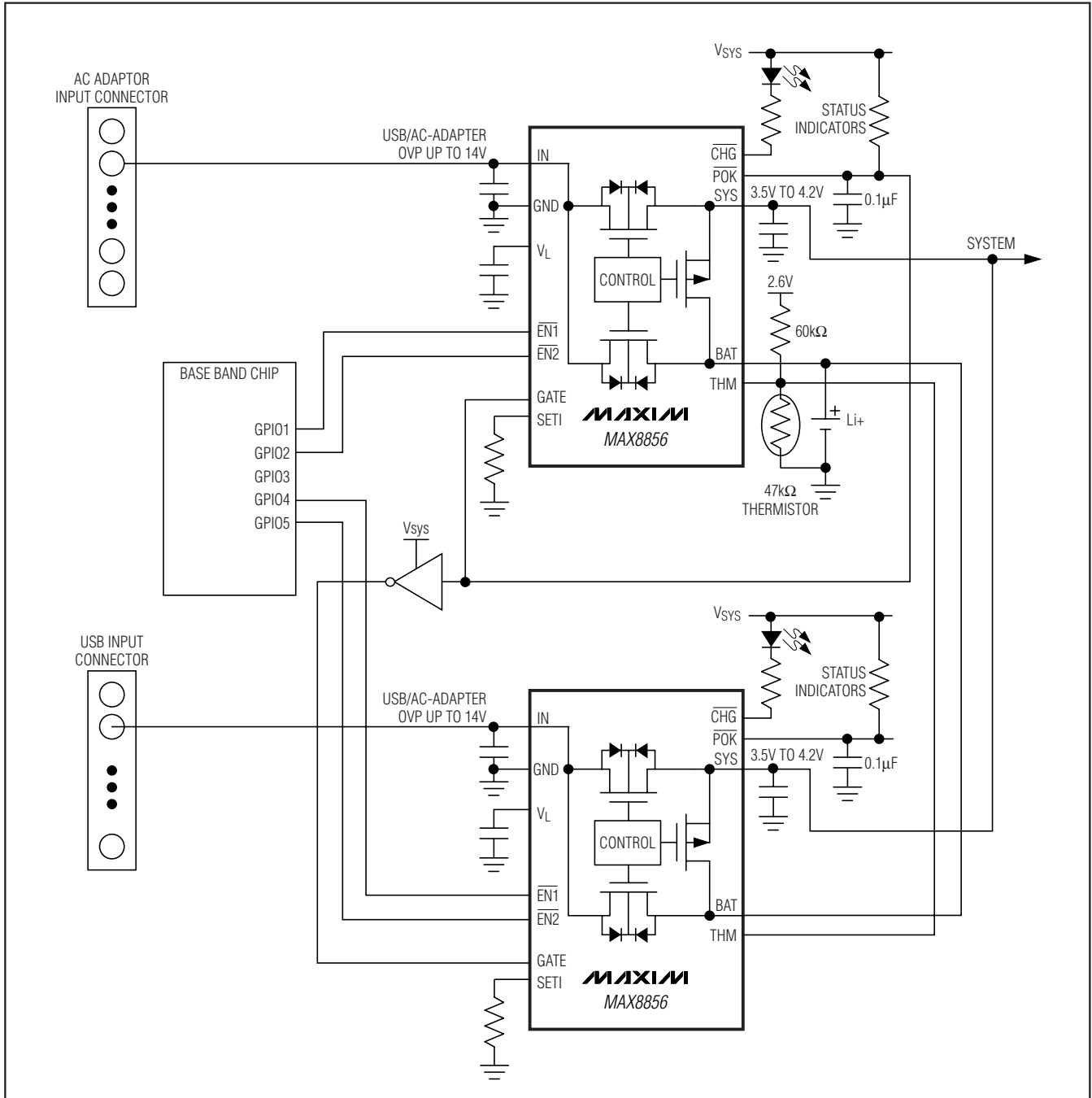

Figure 6. Dual Charger Application

# USB/AC Adapter, Li+ Linear Battery Charger with Integrated 50mΩ Battery Switch in TDFN

## Package Information

For the latest package outline information, go to [www.maxim-ic.com/packages](http://www.maxim-ic.com/packages).

PACKAGE TYPE	PACKAGE CODE	DOCUMENT NO.
14 TDFN-EP	T1433-2	<a href="#">21-0137</a>

MAX8856

Maxim cannot assume responsibility for use of any circuitry other than circuitry entirely embodied in a Maxim product. No circuit patent licenses are implied. Maxim reserves the right to change the circuitry and specifications without notice at any time.

Maxim Integrated Products, 120 San Gabriel Drive, Sunnyvale, CA 94086 408-737-7600 \_\_\_\_\_ 13