

Loch wahlweise vorhanden  
hole selective available

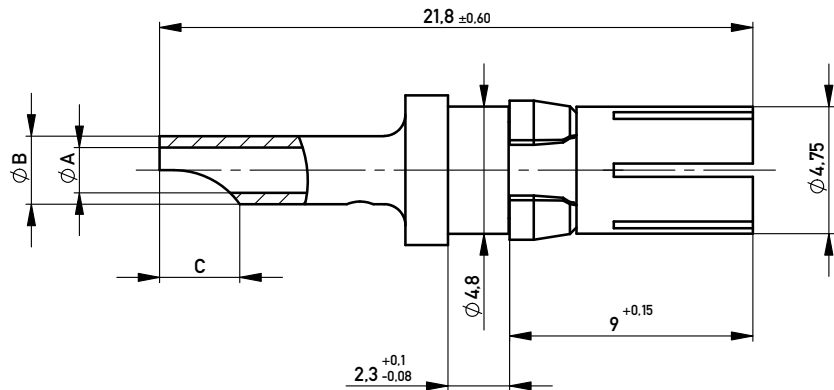

Missing informations  
and dimensions  
see at DIN 41626

M 2:1

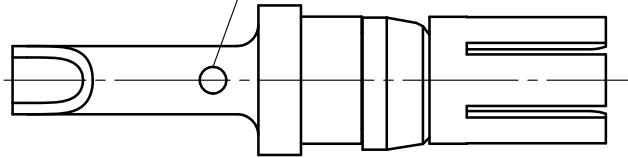
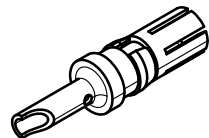

Masse nur informativ  
keine Prüfpläne erstellen.

Technical Data:

Insertion/withdrawal force per contact:  $\leq 10\text{N} / \leq 1.6\text{N}$   
 Mechanical operations:  $\geq 500$   
 Contact resistance:  $\leq 1\text{ m}\Omega$   
 Operation Temperature:  $-55^\circ\text{C} - +125^\circ\text{C}$   
 Solder temperature: according JEDEC 020C  
 Suitable assembly process: leadfree wave / reflow soldering

RoHS compliance: yes (6/6)  
 Designed for use with: straight female DIN, female 2mm HM connector

Packaging: antistatic plastic bag  
 Packaging unit: 100 pieces per bag  
 Marking of packaging: label or direct printed on bag  
 required date see ERNI labeling spec. 254792

Current	Cable cross area	AWG
10 A	1.5 mm <sup>2</sup>	16
20 A	4 mm <sup>2</sup>	12
30 A	6 mm <sup>2</sup>	10
40 A	10 mm <sup>2</sup>	8

594176	1	40 A	2-4 $\mu\text{mNiP}+$ 0.1 $\mu\text{m Au}$	4.8	5.6	5.2
594174	1	20 A		2.9 -0.5	3.7	4.0
594172	1	10 A		1.8	2.5+0.3	3.0
294761	1	40 A	2 - 3 $\mu\text{m Ni}$ min. 1.3 $\mu\text{m Au}$	4.8	5.6	5.2
053456	1	30 A		3.45+0.1	4.5	4.7+0.6
294760	1	20 A		2.9 -0.5	3.7	4.0
294759	1	10 A		1.8	2.5+0.3	3.0
Part-No.	Class	Current	Plating	$\varnothing A$	$\varnothing B$	C

Information:		Tolerances		Scale	5:1
All rights reserved. Only for Information. To ensure that this is the latest version of this drawing, please contact one of the ERNI companies before using.		Subject to modification without prior notice. Drawing will not be updated.		Designation	
		www.ERNI.com		High Current Female Contact Hand Solder Termination	
				053316	
t	18.06.2015			I	
Index	Date			A3	
				Class	STVSKO

Copyright by ERNI Production GmbH & Co., KG  
 Proprietary notice pursuant to ISD 18016 to be observed.